

## FEATURES

- Worldwide NTSC/PAL/SECAM color demodulation support
- One 10-bit ADC, 4× oversampling per channel for CVBS, Y/C, and YPrPb modes
- Analog video input channels with on-chip antialiasing filter
  - ADV7282A: up to 4 input channels
  - ADV7282A-M: up to 6 input channels
- Video input support for CVBS (composite), S-Video (Y/C), and YPrPb (component)
- Fully differential, pseudo differential, and single-ended CVBS video input support
- NTSC/PAL/SECAM autodetection
- STB diagnostics on 2 video inputs
- Up to 4 V common-mode input range solution
- Excellent common-mode noise rejection capabilities
- 5-line adaptive 2D comb filter and CTI video enhancement
- Integrated AGC with adaptive peak white mode
- Fast switching capability
- Integrated I<sup>2</sup>P video output converter (deinterlacer) ACE
- Downdither (8-bit to 6-bit)
- Rovi copy protection detection
- 8-bit ITU-R BT.656 YCrCb 4:2:2 output and HS, VS, or field synchronization (ADV7282A)
- MIPI CSI-2 output interface (ADV7282A-M only)
- Full featured VBI data slicer with WST support
- Power-down mode available
- 2-wire, I<sup>2</sup>C-compatible serial interface
- Qualified for automotive applications
- −40°C to +105°C temperature grade
- 32-lead, 5 mm × 5 mm, RoHS compliant LFCSP

## APPLICATIONS

- Advanced driver assistance
- Automotive infotainment
- DVRs for video security
- Media players

## GENERAL DESCRIPTION

The ADV7282A<sup>1</sup> has the same pinout as and is software compatible with the [ADV7282](#) with the exception of a updated IDENT code. The mobile industry processor interface (MIPI®) model of the ADV7282A (ADV7282A-M) has the same pinout as and is software compatible with the [ADV7282-M](#) with the exception of an updated IDENT code.

All features, functionality, and specifications are shared by the ADV7282A and the ADV7282A-M, unless otherwise noted.

The ADV7282A is a versatile one-chip, multiformat video decoder that automatically detects standard analog baseband video signals and converts them into YCrCb 4:2:2 component video data streams.

The analog input of the ADV7282A features an input mux (4-channel on ADV7282A, 6-channel on ADV7282A-M), a single 10-bit analog-to-digital converter (ADC) and an on-chip differential to single-ended converter to accommodate the direct connection of differential, pseudo differential, or single-ended CVBS without the need for external amplifier circuitry.

The standard definition processor (SDP) in the ADV7282A automatically detects PAL, NTSC and SECAM standards in the form of composite, S-Video (Y/C) and component. The analog video is converted into a 4:2:2 component video data stream that is output either via an 8-bit ITU-R BT.656 standard-compatible interface (ADV7282A) or via a MIPI CSI-2 Tx (hereafter referred to as MIPI Tx) interface (ADV7282A-M). The ADV7282A also feature a deinterlacer for interlaced to progressive (I<sup>2</sup>P) conversion.

The ADV7282A offers short to battery (STB) diagnostic sense inputs and general-purpose outputs.

The ADV7282A is provided in a space-saving LFCSP surface-mount, RoHS compliant package. The ADV7282A is rated over the −40°C to +105°C temperature range, making it ideal for automotive applications.

The ADV7282A must be configured in accordance with the I<sup>2</sup>C writes provided in the evaluation board script files available at [www.analog.com/ADV7282A](http://www.analog.com/ADV7282A).

<sup>1</sup> Protected by U.S. Patent 5,784,120.

## TABLE OF CONTENTS

|   |    |   |    |
|---|----|---|----|
| Features .....  | 1  | Input Networks .....                                | 17 |
| Applications .....  | 1  | Single-Ended Input Network .....                    | 17 |
| General Description .....   | 1  | Differential Input Network .....                    | 17 |
| Revision History .....  | 2  | STB Protection .....                                | 17 |
| Functional Block Diagrams .....   | 3  | Applications Information .....                      | 18 |
| Specifications .....  | 4  | Input Configuration .....                           | 18 |
| Electrical Specifications .....   | 4  | STB Diagnostics .....                               | 18 |
| Video Specifications .....  | 5  | Programming the STB Diagnostic Function .....       | 19 |
| Analog Specifications .....   | 6  | Adaptive Contrast Enhancement (ACE) .....           | 20 |
| Clock and I <sup>2</sup> C Timing Specifications .....                    | 6  | I <sup>2</sup> P Function .....                     | 20 |
| MIPI Tx Video Output and Timing Specifications<br>(ADV7282A-M Only) ..... | 7  | ITU-R BT.656 Tx Configuration (ADV7282A Only) ..... | 20 |
| Pixel Port Timing Specifications (ADV7282A Only) .....                    | 9  | MIPI Tx Output (ADV7282A-M Only) .....              | 21 |
| Absolute Maximum Ratings .....  | 10 | I <sup>2</sup> C Port Description .....             | 21 |
| Thermal Resistance .....  | 10 | Register Maps .....                                 | 23 |
| ESD Caution .....   | 10 | PCB Layout Recommendations .....                    | 25 |
| Pin Configurations and Function Descriptions .....                        | 11 | Analog Interface Inputs .....                       | 25 |
| Theory of Operation .....   | 13 | Power Supply Decoupling .....                       | 25 |
| Analog Front End .....  | 13 | VREFN and VREFP Pins .....                          | 25 |
| Standard Definition Processor (SDP) .....                                 | 13 | Digital Outputs .....                               | 25 |
| Power Supply Sequencing .....   | 15 | Exposed Metal Pad .....                             | 25 |
| Optimal Power-Up Sequence .....   | 15 | Digital Inputs .....                                | 25 |
| Simplified Power-Up Sequence .....  | 15 | MIPI Tx Outputs (ADV7282A-M Only) .....             | 25 |
| Power-Down Sequence .....   | 15 | Typical Circuit Connections .....                   | 26 |
| DVDDIO Supply Voltage .....   | 15 | Outline Dimensions .....                            | 28 |
| Crystal Oscillator Design .....   | 16 | Ordering Guide .....                                | 28 |
|   |    | Automotive Products .....                           | 28 |

## REVISION HISTORY

### 5/2018—Rev. 0 to Rev. A

|  |   |
|--|---|
| Changes to General Description Section ..... | 1 |
|--|---|

### 9/2017—Revision 0: Initial Version

# FUNCTIONAL BLOCK DIAGRAMS

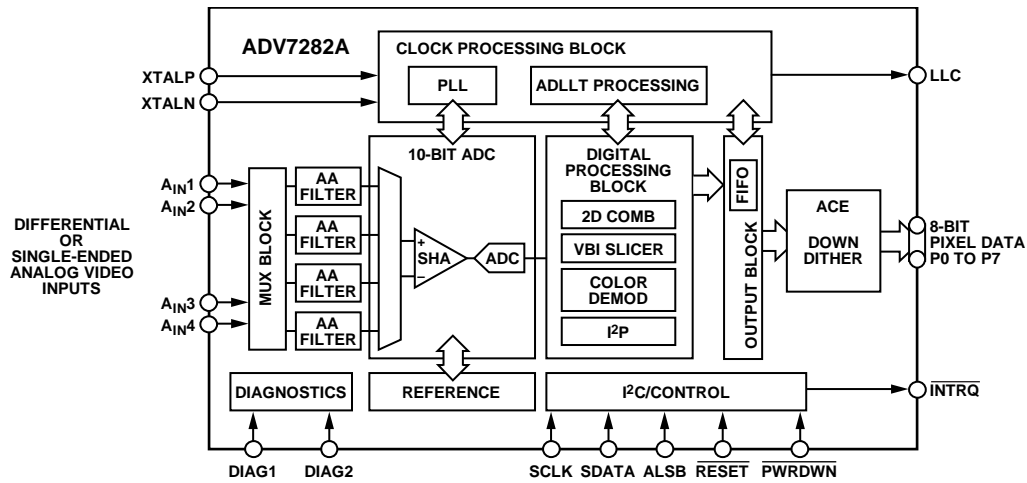

Figure 1. ADV7282A Functional Block Diagram

16148-001

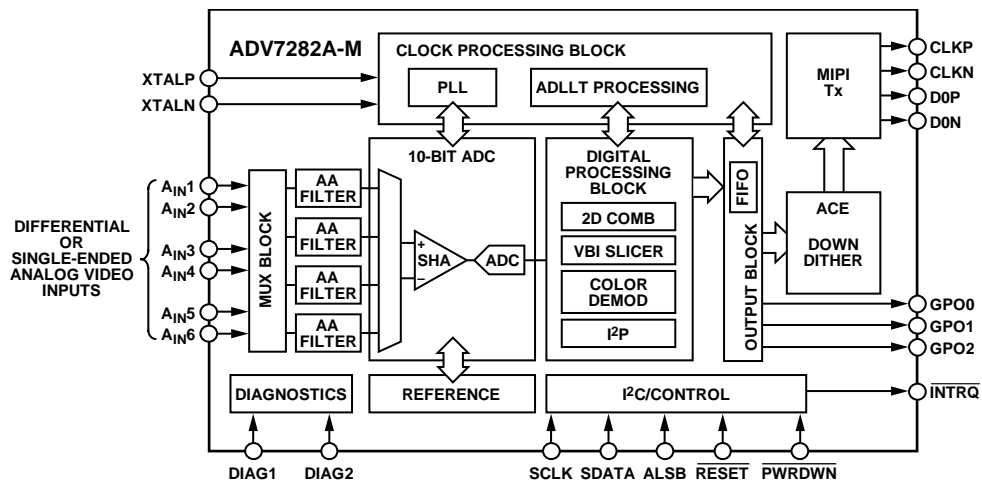

Figure 2. ADV7282A-M Functional Block Diagram

16148-002

## SPECIFICATIONS

### ELECTRICAL SPECIFICATIONS

$P_{VDD}$ ,  $A_{VDD}$ ,  $D_{VDD}$ , and  $M_{VDD}$  = 1.71 V to 1.89 V,  $D_{VDDIO}$  = 2.97 V to 3.63 V, specified at the operating temperature range, unless otherwise noted.  $M_{VDD}$  only applies to the ADV7282A-M.

Table 1.

| Parameter                               | Symbol       | Test Conditions/Comments  | Min  | Typ  | Max  | Unit |
|---|--------------|---|------|------|------|------|
| STATIC PERFORMANCE                      |              |   |      |      |      |      |
| ADC Resolution                          | N            |   |      |      | 10   | Bits |
| Integral Nonlinearity                   | INL          | CVBS mode   |      | 2    |      | LSB  |
| Differential Nonlinearity               | DNL          | CVBS mode   |      | ±0.6 |      | LSB  |
| DIGITAL INPUTS                          |              |   |      |      |      |      |
| Input High Voltage                      | $V_{IH}$     | $D_{VDDIO} = 3.3\text{ V}$  | 2    |      |      | V    |
|   |              | $D_{VDDIO} = 1.8\text{ V}$ , ADV7282A only                                | 1.2  |      |      | V    |
| Input Low Voltage                       | $V_{IL}$     | $D_{VDDIO} = 3.3\text{ V}$  |      |      | 0.8  | V    |
|   |              | $D_{VDDIO} = 1.8\text{ V}$ , ADV7282A only                                |      |      | 0.4  | V    |
| Input Leakage Current                   | $I_{IN}$     | RESET pin   | -10  |      | +10  | μA   |
|   |              | SDATA, SCLK pins  | -10  |      | +15  | μA   |
|   |              | PWRDWN, ALSB pins   | -10  |      | +50  | μA   |
| Input Capacitance                       | $C_{IN}$     |   |      |      | 10   | pF   |
| CRYSTAL INPUT                           |              |   |      |      |      |      |
| Input High Voltage                      | $V_{IH}$     | XTALN pin   | 1.2  |      |      | V    |
| Input Low Voltage                       | $V_{IL}$     | XTALN pin   |      |      | 0.4  | V    |
| DIGITAL OUTPUTS                         |              |   |      |      |      |      |
| Output High Voltage                     | $V_{OH}$     | $D_{VDDIO} = 3.3\text{ V}$ , $I_{SOURCE} = 0.4\text{ mA}$                 | 2.4  |      |      | V    |
|   |              | $D_{VDDIO} = 1.8\text{ V}$ , $I_{SOURCE} = 0.4\text{ mA}$ , ADV7282A only | 1.4  |      |      | V    |
| Output Low Voltage                      | $V_{OL}$     | $D_{VDDIO} = 3.3\text{ V}$ , $I_{SINK} = 3.2\text{ mA}$                   |      |      | 0.4  | V    |
|   |              | $D_{VDDIO} = 1.8\text{ V}$ , $I_{SINK} = 1.6\text{ mA}$ , ADV7282A only   |      |      | 0.2  | V    |
| High Impedance Leakage Current          | $I_{LEAK}$   |   |      |      | 10   | μA   |
| Output Capacitance                      | $C_{OUT}$    |   |      |      | 20   | pF   |
| POWER REQUIREMENTS <sup>1, 2, 3</sup>   |              |   |      |      |      |      |
| Digital Input/Output (I/O) Power Supply | $D_{VDDIO}$  | ADV7282A-M  | 2.97 | 3.3  | 3.63 | V    |
|   |              | ADV7282A  | 1.62 | 3.3  | 3.63 | V    |
| PLL Power Supply                        | $P_{VDD}$    |   | 1.71 | 1.8  | 1.89 | V    |
| Analog Power Supply                     | $A_{VDD}$    |   | 1.71 | 1.8  | 1.89 | V    |
| Digital Power Supply                    | $D_{VDD}$    |   | 1.71 | 1.8  | 1.89 | V    |
| MIPI Transmitter (Tx) Power Supply      | $M_{VDD}$    | ADV7282A-M only   | 1.71 | 1.8  | 1.89 | V    |
| Digital I/O Supply Current              | $I_{DVDDIO}$ | ADV7282A-M  |      | 1.5  |      | mA   |
|   |              | ADV7282A  |      | 5    |      | mA   |
| PLL Supply Current                      | $I_{PVDD}$   |   |      | 12   |      | mA   |
| MIPI Tx Supply Current                  | $I_{MVDD}$   | ADV7282A-M only   |      | 14   |      | mA   |
| Analog Supply Current                   | $I_{AVDD}$   |   |      |      |      |      |
| Single-Ended CVBS Input                 |              |   |      | 47   |      | mA   |
| Differential CVBS Input                 |              | Fully differential and pseudo differential CVBS                           |      | 69   |      | mA   |
| Y/C Input                               |              |   |      | 60   |      | mA   |
| YPrPb Input                             |              |   |      | 75   |      | mA   |
| Digital Supply Current                  | $I_{DVDD}$   |   |      |      |      |      |
| Single-Ended CVBS Input                 |              |   |      | 70   |      | mA   |
| Differential CVBS Input                 |              | Fully differential and pseudo differential CVBS                           |      | 70   |      | mA   |
| Y/C Input                               |              |   |      | 70   |      | mA   |
| YPrPb Input                             |              |   |      | 70   |      | mA   |

| Parameter                                  | Symbol                 | Test Conditions/Comments | Min | Typ | Max | Unit |
|--|------------------------|--------------------------|-----|-----|-----|------|
| <b>POWER-DOWN CURRENTS<sup>1</sup></b>     |                        |                          |     |     |     |      |
| Digital I/O Supply                         | I <sub>DVDDIO_PD</sub> |                          |     | 73  |     | μA   |
| PLL Supply                                 | I <sub>PVDD_PD</sub>   |                          |     | 46  |     | μA   |
| Analog Supply                              | I <sub>AVDD_PD</sub>   |                          |     | 0.2 |     | μA   |
| Digital Supply                             | I <sub>DVDD_PD</sub>   |                          |     | 420 |     | μA   |
| MIPI Tx Supply                             | I <sub>MVDD_PD</sub>   |                          |     | 4.5 |     | μA   |
| Total Power Dissipation in Power-Down Mode |                        |                          |     | 1   |     | mW   |
| <b>CRYSTAL OSCILLATOR<sup>1</sup></b>      |                        |                          |     |     |     |      |
| Transconductance                           | g <sub>M</sub>         |                          |     | 30  |     | mA/V |

<sup>1</sup> Guaranteed by characterization.

<sup>2</sup> Typical current consumption values are measured with nominal voltage supply levels and a Society of Motion Picture and Television Engineers (SMPTE) bar test pattern.

<sup>3</sup> All specifications apply when the I<sup>2</sup>P core is activated, unless otherwise stated.

## VIDEO SPECIFICATIONS

V<sub>VDD</sub>, A<sub>VDD</sub>, D<sub>VDD</sub>, and M<sub>VDD</sub> = 1.71 V to 1.89 V, D<sub>VDDIO</sub> = 2.97 V to 3.63 V, specified at operating temperature range, unless otherwise noted. Specifications guaranteed by characterization. M<sub>VDD</sub> only applies to the ADV7282A-M.

**Table 2.**

| Parameter                                   | Symbol          | Test Conditions/Comments        | Min | Typ  | Max | Unit    |
|---|-----------------|---------------------------------|-----|------|-----|---------|
| <b>NONLINEAR SPECIFICATIONS<sup>1</sup></b> |                 |                                 |     |      |     |         |
| Differential Phase                          | DP              | CVBS input, modulated five-step |     | 0.9  |     | Degrees |
| Differential Gain                           | DG              | CVBS input, modulated five-step |     | 0.5  |     | %       |
| Luma Nonlinearity                           | LNL             | CVBS input, five-step           |     | 2.0  |     | %       |
| <b>NOISE SPECIFICATIONS</b>                 |                 |                                 |     |      |     |         |
| Signal-to-Noise Ratio, Unweighted           | SNR             | Luma ramp                       |     | 57.1 |     | dB      |
|   |                 | Luma flat field                 |     | 58   |     | dB      |
| Analog Front-End Crosstalk                  |                 |                                 |     | 60   |     | dB      |
| Common-Mode Rejection Ratio <sup>2</sup>    | CMRR            |                                 |     | 73   |     | dB      |
| <b>LOCK TIME SPECIFICATIONS</b>             |                 |                                 |     |      |     |         |
| Horizontal Lock Range                       |                 |                                 | -5  |      | +5  | %       |
| Vertical Lock Range                         |                 |                                 | 40  |      | 70  | Hz      |
| Subcarrier Lock Range                       | f <sub>sc</sub> |                                 |     | ±1.3 |     | kHz     |
| Color Lock In Time                          |                 |                                 |     | 60   |     | Lines   |
| Synchronization Depth Range                 |                 |                                 | 20  |      | 200 | %       |
| Color Burst Range                           |                 |                                 | 5   |      | 200 | %       |
| Vertical Lock Time                          |                 |                                 |     | 2    |     | Fields  |
| Autodetection Switch Speed <sup>3</sup>     |                 |                                 |     | 100  |     | Lines   |
| Fast Switch Speed <sup>4</sup>              |                 |                                 |     | 100  |     | ms      |
| <b>LUMA SPECIFICATIONS</b>                  |                 |                                 |     |      |     |         |
| Luma Brightness Accuracy                    |                 | CVBS, 1 V input                 |     | 1    |     | %       |
| Luma Contrast Accuracy                      |                 |                                 |     | 1    |     | %       |

<sup>1</sup> These specifications apply for all CVBS input types (NTSC, PAL, and SECAM), as well as for single-ended and differential CVBS inputs.

<sup>2</sup> The CMRR of this circuit design is critically dependent on the external resistor matching on the circuit inputs (see the Input Networks section). The CMRR measurement was performed with 0.1% tolerant resistors, a common-mode voltage of 1 V, and a common-mode frequency of 10 kHz.

<sup>3</sup> Autodetection switch speed is the time required for the ADV7282A to detect which video format is present at its input, for example, PAL I or NTSC M.

<sup>4</sup> Fast switch speed is the time required for the ADV7282A to switch from one analog input (single-ended or differential) to another, for example, switching from A<sub>IN1</sub> to A<sub>IN2</sub>.

**ANALOG SPECIFICATIONS**

$P_{VDD}$ ,  $A_{VDD}$ ,  $D_{VDD}$ , and  $M_{VDD}$  = 1.71 V to 1.89 V,  $D_{VDDIO}$  = 2.97 V to 3.63 V, specified at operating temperature range, unless otherwise noted. Specifications guaranteed by characterization.  $M_{VDD}$  only applies to the ADV7282A-M.

Table 3.

| Parameter                  | Test Conditions/Comments | Min | Typ | Max | Unit       |
|----------------------------|--------------------------|-----|-----|-----|------------|
| CLAMP CIRCUITRY            |                          |     |     |     |            |
| External Clamp Capacitor   | Clamps switched off      |     | 0.1 |     | $\mu$ F    |
| Input Impedance            |                          |     | 10  |     | M $\Omega$ |
| Large Clamp Source Current |                          |     | 0.4 |     | mA         |
| Large Clamp Sink Current   |                          |     | 0.4 |     | mA         |
| Fine Clamp Source Current  |                          |     | 10  |     | $\mu$ A    |
| Fine Clamp Sink Current    |                          |     | 10  |     | $\mu$ A    |

**CLOCK AND I<sup>2</sup>C TIMING SPECIFICATIONS**

$A_{VDD}$ ,  $D_{VDD}$ ,  $P_{VDD}$ , and  $M_{VDD}$  = 1.71 V to 1.89 V,  $D_{VDDIO}$  = 2.97 V to 3.63 V, specified at operating temperature range, unless otherwise noted. Specifications guaranteed by characterization.  $M_{VDD}$  only applies to the ADV7282A-M.

Table 4.

| Parameter                             | Symbol | Min | Typ      | Max      | Unit    |
|---------------------------------------|--------|-----|----------|----------|---------|
| SYSTEM CLOCK AND CRYSTAL              |        |     |          |          |         |
| Nominal Frequency                     |        |     | 28.63636 |          | MHz     |
| Frequency Stability                   |        |     |          | $\pm$ 50 | ppm     |
| I <sup>2</sup> C PORT                 |        |     |          |          |         |
| SCLK Frequency                        |        |     |          | 400      | kHz     |
| SCLK Minimum Pulse Width High         | $t_1$  | 0.6 |          |          | $\mu$ s |
| SCLK Minimum Pulse Width Low          | $t_2$  | 1.3 |          |          | $\mu$ s |
| Hold Time (Start Condition)           | $t_3$  | 0.6 |          |          | $\mu$ s |
| Setup Time (Start Condition)          | $t_4$  | 0.6 |          |          | $\mu$ s |
| SDATA Setup Time                      | $t_5$  | 100 |          |          | ns      |
| SCLK and SDATA Rise Times             | $t_6$  |     |          | 300      | ns      |
| SCLK and SDATA Fall Times             | $t_7$  |     |          | 300      | ns      |
| Setup Time (Stop Condition)           | $t_8$  |     | 0.6      |          | $\mu$ s |
| RESET INPUT                           |        |     |          |          |         |
| $\overline{\text{RESET}}$ Pulse Width |        | 5   |          |          | ms      |

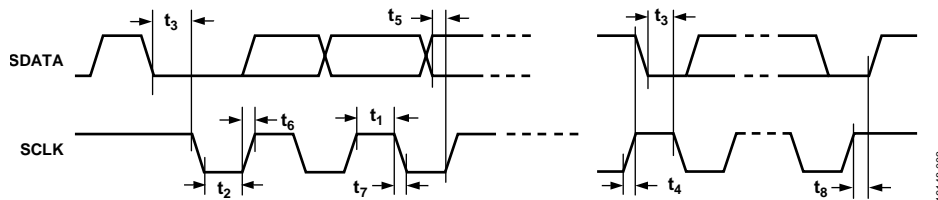

Figure 3. I<sup>2</sup>C Timing Diagram

16148-003

**MIPI Tx VIDEO OUTPUT AND TIMING SPECIFICATIONS (ADV7282A-M ONLY)**

$P_{VDD}$ ,  $A_{VDD}$ ,  $D_{VDD}$ , and  $M_{VDD} = 1.71\text{ V to }1.89\text{ V}$ ,  $D_{VDDIO} = 2.97\text{ V to }3.63\text{ V}$ , specified at operating temperature range, unless otherwise noted. The ADV7282A MIPI Tx conforms to the MIPI D-PHY Version 1.00.00 specification by characterization. The MIPI Tx clock lane of the ADV7282A-M remains in high speed mode even when the data lane enters low power (LP) mode. For this reason, some measurements on the clock lane that pertain to low power mode are not applicable. Unless otherwise stated, all high speed measurements were performed with the ADV7282A-M operating in progressive mode and with a nominal 432 Mbps output data rate. Specifications guaranteed by characterization.

**Table 5.**

| Parameter  | Symbol   | Test Conditions/Comments   | Min | Typ  | Max | Unit  |
|--|----------|--|-----|------|-----|-------|
| UNIT INTERVAL  | UI       |  |     |      |     |       |
| Interlaced Output  |          |  |     | 4.63 |     | ns    |
| Progressive Output   |          |  |     | 2.31 |     | ns    |
| DATA LANE LP MIPI Tx DC SPECIFICATIONS <sup>1</sup>        |          |  |     |      |     |       |
| Thevenin Output High Level                                 | $V_{OH}$ |  | 1.1 | 1.2  | 1.3 | V     |
| Thevenin Output Low Level                                  | $V_{OL}$ |  | -50 | 0    | +50 | mV    |
| DATA LANE LP MIPI Tx AC SPECIFICATIONS <sup>1</sup>        |          |  |     |      |     |       |
| Rise Time, 15% to 85%                                      |          |  |     |      | 25  | ns    |
| Fall Time, 85% to 15%                                      |          |  |     |      | 25  | ns    |
| Rise Time, 30% to 85%                                      |          |  |     |      | 35  | ns    |
| Data Lane LP Slew Rate vs. Load Capacitance ( $C_{LOAD}$ ) |          |  |     |      |     |       |
| Maximum Slew Rate over Entire Vertical Edge Region         |          | Rising edge  |     |      | 150 | mV/ns |
|  |          | Falling edge   |     |      | 150 | mV/ns |
| Minimum Slew Rate  |          |  |     |      |     |       |
| 400 mV $\leq V_{OUT} \leq$ 930 mV                          |          | Falling edge   | 30  |      |     | mV/ns |
| 400 mV $\leq V_{OUT} \leq$ 700 mV                          |          | Rising edge  | 30  |      |     | mV/ns |
| 700 mV $\leq V_{OUT} \leq$ 930 mV                          |          | Rising edge  | >0  |      |     | mV/ns |
| Pulse Width of LP Exclusive OR Clock                       |          | First clock pulse after stop state or last pulse before stop state | 40  |      |     | ns    |
|  |          | All other clock pulses   | 20  |      |     | ns    |
| Period of LP Exclusive OR Clock                            |          |  | 90  |      |     | ns    |
| CLOCK LANE LP MIPI Tx DC SPECIFICATIONS <sup>1</sup>       |          |  |     |      |     |       |
| Thevenin Output High Level                                 | $V_{OH}$ |  | 1.1 | 1.2  | 1.3 | V     |
| Thevenin Output Low Level                                  | $V_{OL}$ |  | -50 | 0    | +50 | mV    |
| CLOCK LANE LP MIPI Tx AC SPECIFICATIONS <sup>1</sup>       |          |  |     |      |     |       |
| Rise Time, 15% to 85%                                      |          |  |     |      | 25  | ns    |
| Fall Time, 85% to 15%                                      |          |  |     |      | 25  | ns    |
| Clock Lane LP Slew Rate                                    |          |  |     |      |     |       |
| Maximum Slew Rate over Entire Vertical Edge Region         |          | Rising edge  |     |      | 150 | mV/ns |
|  |          | Falling edge   |     |      | 150 | mV/ns |
| Minimum Slew Rate  |          |  |     |      |     |       |
| 400 mV $\leq V_{OUT} \leq$ 930 mV                          |          | Falling edge   | 30  |      |     | mV/ns |
| 400 mV $\leq V_{OUT} \leq$ 700 mV                          |          | Rising edge  | 30  |      |     | mV/ns |
| 700 mV $\leq V_{OUT} \leq$ 930 mV                          |          | Rising edge  | >0  |      |     | mV/ns |

| Parameter   | Symbol         | Test Conditions/Comments   | Min                    | Typ | Max                    | Unit   |
|---|----------------|--|------------------------|-----|------------------------|--------|
| DATA LANE HIGH SPEED MIPI Tx SIGNALING REQUIREMENTS       |                | See Figure 4   |                        |     |                        |        |
| LP to High Speed Transition Stage                         | $t_9$          | Time that the D0P pin is at $V_{OL}$ and the D0N pin is at $V_{OH}$  | 50                     |     |                        | ns     |
|   | $t_{10}$       | Time that the D0P and D0N pins are at $V_{OL}$   | $40 + (4 \times UI)$   |     | $85 + (6 \times UI)$   | ns     |
|   | $t_{11}$       | $t_{10}$ plus the high speed zero period   | $145 + (10 \times UI)$ |     |                        | ns     |
| High Speed Differential Voltage Swing                     | V <sub>1</sub> |  | 140                    | 200 | 270                    | mV p-p |
| Differential Voltage Mismatch                             |                |  |                        |     | 10                     | mV     |
| Single-Ended Output High Voltages                         |                |  |                        |     | 360                    | mV     |
| Static Common-Mode Voltage Level                          |                |  | 150                    | 200 | 250                    | mV     |
| Static Common-Mode Voltage Mismatch                       |                |  |                        |     | 5                      | mV     |
| Dynamic Common Level Variations                           |                |  |                        |     |                        |        |
| 50 MHz to 450 MHz   |                |  |                        |     | 25                     | mV     |
| Above 450 MHz   |                |  |                        |     | 15                     | mV     |
| Rise Time, 20% to 80%                                     |                |  | 0.15                   |     | $0.3 \times UI$        | ns     |
| Fall Time, 80% to 20%                                     |                |  | 0.15                   |     | $0.3 \times UI$        | ns     |
| High Speed to LP Transition Stage                         | $t_{12}$       | Time that the ADV7282A-M drives the flipped last data bit after sending the last payload data bit of a high speed transmission burst | $60 + (4 \times UI)$   |     |                        | ns     |
|   | $t_{13}$       | Post end of transmission rise time (30% to 85%)  |                        |     | 35                     | ns     |
|   | $t_{14}$       | Time from start of $t_{12}$ to start of low power state following a high speed transmission burst                                    |                        |     | $105 + (12 \times UI)$ | ns     |
|   | $t_{15}$       | Time that a low power state is transmitted after a high speed transmission burst   |                        |     | 100                    | ns     |
| CLOCK LANE HIGH SPEED MIPI Tx SIGNALING REQUIREMENTS      |                | See Figure 4   |                        |     |                        |        |
| LP to High Speed Transition Stage <sup>2</sup>            |                | Time that the CLKP pin is at $V_{OL}$ and the CLKN pin is at $V_{OH}$  | 50                     |     |                        | ns     |
|   |                | Time that the CLKP and CLKN pins are at $V_{OL}$   | 38                     |     | 95                     | ns     |
|   |                | Clock high speed zero period   | 300                    | 500 |                        | ns     |
| High Speed Differential Voltage Swing                     | V <sub>2</sub> |  | 140                    | 200 | 270                    | mV p-p |
| Differential Voltage Mismatch                             |                |  |                        |     | 10                     | mV     |
| Single-Ended Output High Voltages                         |                |  |                        |     | 360                    | mV     |
| Static Common-Mode Voltage Level                          |                |  | 150                    | 200 | 250                    | mV     |
| Static Common-Mode Voltage Mismatch                       |                |  |                        |     | 5                      | mV     |
| Dynamic Common Level Variations                           |                |  |                        |     |                        |        |
| 50 MHz to 450 MHz   |                |  |                        |     | 25                     | mV     |
| Above 450 MHz   |                |  |                        |     | 15                     | mV     |
| Rise Time, 20% to 80%                                     |                |  | 0.15                   |     | $0.3 \times UI$        | ns     |
| Fall Time, 80% to 20%                                     |                |  | 0.15                   |     | $0.3 \times UI$        | ns     |
| HIGH SPEED MIPI Tx CLOCK TO DATA LANE TIMING REQUIREMENTS |                |  |                        |     |                        |        |
| Data to Clock Skew  |                |  | $0.35 \times UI$       |     | $0.65 \times UI$       | ns     |

<sup>1</sup> These measurements were performed with  $C_{LOAD} = 50$  pF.

<sup>2</sup> The clock lane remains in high speed mode throughout normal operation. These results apply only to the ADV7282A-M during startup.



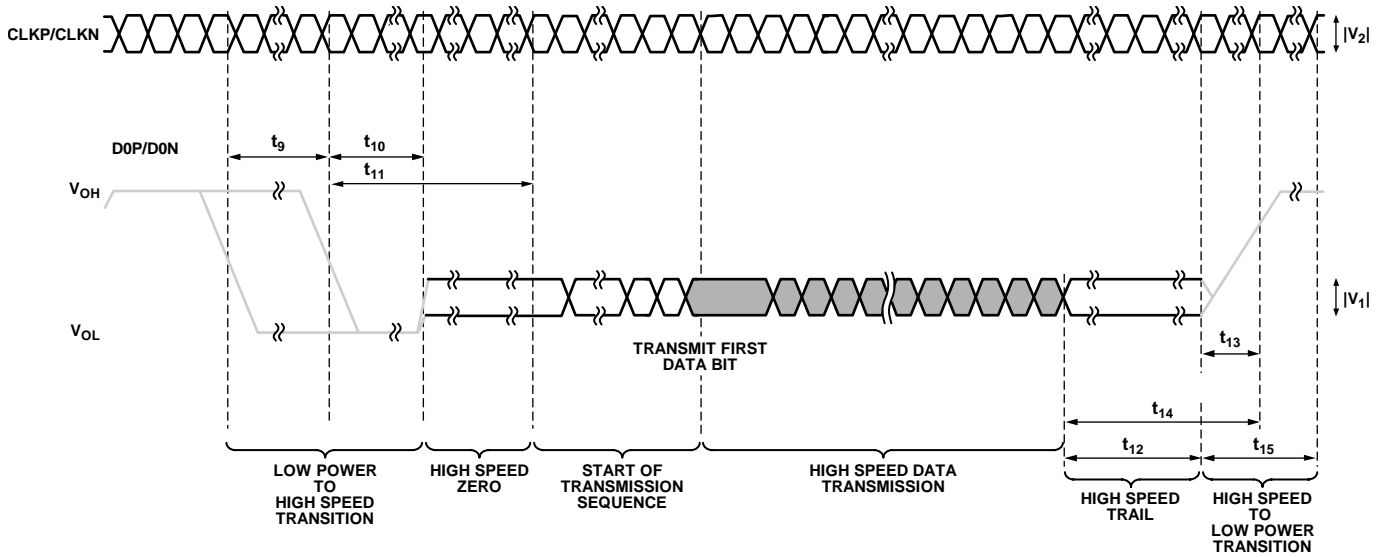

Figure 4. ADV7282A-M Output Timing Diagram (Conforms with MIPI Tx Specification)

**PIXEL PORT TIMING SPECIFICATIONS (ADV7282A ONLY)**

$A_{VDD}$ ,  $D_{VDD}$ , and  $P_{VDD} = 1.71\text{ V to }1.89\text{ V}$ ,  $D_{VDDIO} = 1.62\text{ V to }3.63\text{ V}$ , specified at operating temperature range, unless otherwise noted. Specifications guaranteed by characterization.

Table 6.

| Parameter                     | Symbol          | Test Conditions/Comments  | Min   | Typ | Max   | Unit         |
|-------------------------------|-----------------|---|-------|-----|-------|--------------|
| CLOCK OUTPUTS                 |                 |   |       |     |       |              |
| LLC Mark Space Ratio          | $t_{16}:t_{17}$ |   | 45:55 |     | 55:45 | % duty cycle |
| DATA AND CONTROL OUTPUTS      |                 |   |       |     |       |              |
| Data Output Transitional Time | $t_{18}$        | Negative clock edge to start of valid data<br>( $t_{SETUP} = t_{17} - t_{18}$ ) |       |     | 3.8   | ns           |
|                               | $t_{19}$        | End of valid data to negative clock edge<br>( $t_{HOLD} = t_{16} - t_{19}$ )    |       |     | 6.9   | ns           |

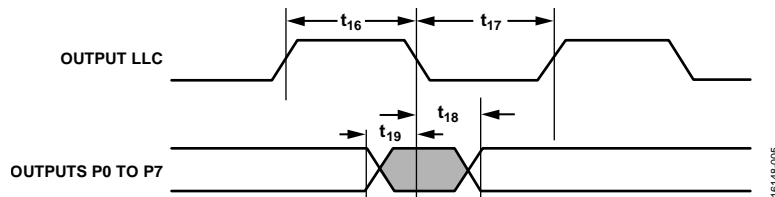

Figure 5. ADV7282A Pixel Port and Control Output Timing Diagram

## ABSOLUTE MAXIMUM RATINGS

Table 7.

| Parameter <sup>1</sup>                                | Rating                                    |
|---|---|
| A <sub>VDD</sub> to GND                               | 2.2 V                                     |
| D <sub>VDD</sub> to GND                               | 2.2 V                                     |
| P <sub>VDD</sub> to GND                               | 2.2 V                                     |
| M <sub>VDD</sub> to GND <sup>2</sup>                  | 2.2 V                                     |
| D <sub>VDDIO</sub> to GND                             | 4 V                                       |
| P <sub>VDD</sub> to D <sub>VDD</sub>                  | −0.9 V to +0.9 V                          |
| M <sub>VDD</sub> to D <sub>VDD</sub> <sup>2</sup>     | −0.9 V to +0.9 V                          |
| A <sub>VDD</sub> to D <sub>VDD</sub>                  | −0.9 V to +0.9 V                          |
| Digital Inputs Voltage                                | GND − 0.3 V to D <sub>VDDIO</sub> + 0.3 V |
| Digital Outputs Voltage                               | GND − 0.3 V to D <sub>VDDIO</sub> + 0.3 V |
| Analog Inputs to Ground                               | GND − 0.3 V to A <sub>VDD</sub> + 0.3 V   |
| Maximum Junction Temperature<br>(T <sub>J MAX</sub> ) | 125°C                                     |
| Storage Temperature Range                             | −65°C to +150°C                           |
| Reflow Soldering (20 sec)                             | JEDEC J-STD-020                           |

<sup>1</sup> The absolute maximum ratings assume that the DGND pins and the exposed pad of the ADV7282A are connected together to a common ground plane (GND). This is part of the recommended layout scheme. See the PCB Layout Recommendations section for more information. The absolute maximum ratings are stated in relation to this common ground plane.

<sup>2</sup> M<sub>VDD</sub> only applies to the ADV7282A-M.

Stresses at or above those listed under Absolute Maximum Ratings may cause permanent damage to the product. This is a stress rating only; functional operation of the product at these or any other conditions above those indicated in the operational section of this specification is not implied. Operation beyond the maximum operating conditions for extended periods may affect product reliability.

## THERMAL RESISTANCE

Thermal performance is directly linked to printed circuit board (PCB) design and operating environment. Careful attention to PCB thermal design is required.

$\theta_{JA}$  is the natural convection junction to ambient thermal resistance measured in a one cubic foot sealed enclosure as per JEDEC JESD51.  $\Psi_{JT}$  is the junction to top thermal characterization parameter measured on a standard test board, as per JEDEC JESD51, allowing the heat generated in the ADV7282A die to flow normally along preferred thermal conduction paths that more closely represent the thermal flows in a typical application board.

Table 8. Thermal Resistance

| Package               | $\theta_{JA}$ | $\Psi_{JT}$ | Unit |
|-----------------------|---------------|-------------|------|
| CP-32-12 <sup>1</sup> | 39.6          | 0.86        | °C/W |

<sup>1</sup> JEDEC JESD51 2s2p 4-layer PCB with two signal layers and two buried solid ground planes (GND), and with nine thermal vias connecting the exposed pad to the ground plane (GND).

## ESD CAUTION



**ESD (electrostatic discharge) sensitive device.** Charged devices and circuit boards can discharge without detection. Although this product features patented or proprietary protection circuitry, damage may occur on devices subjected to high energy ESD. Therefore, proper ESD precautions should be taken to avoid performance degradation or loss of functionality.

## PIN CONFIGURATIONS AND FUNCTION DESCRIPTIONS

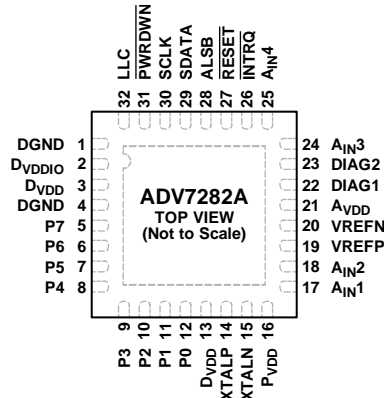

NOTES  
 1. THE EXPOSED PAD MUST BE CONNECTED, TOGETHER WITH THE DGND PINS, TO A COMMON GROUND PLANE (GND).  
 16148-006

Figure 6. ADV7282A Pin Configuration

Table 9. Pin Function Descriptions, ADV7282A

| Pin No.        | Mnemonic     | Type         | Description  |
|----------------|--------------|--------------|--|
| 1, 4           | DGND         | Ground       | Ground for Digital Supply.   |
| 2              | DVDDIO       | Power        | Digital I/O Power Supply (1.8 V or 3.3 V).   |
| 3, 13          | DVDD         | Power        | Digital Power Supply (1.8 V).  |
| 5 to 12        | P7 to P0     | Output       | Video Pixel Output Ports.  |
| 14             | XTALP        | Output       | Output Pin for the Crystal Oscillator Amplifier. Connect this pin to the external 28.63636 MHz crystal, or leave it unconnected if an external 1.8 V, 28.63636 MHz clock oscillator source is used to clock the ADV7282A. The crystal used with the ADV7282A must be a fundamental mode crystal. |
| 15             | XTALN        | Input        | Input Pin for the Crystal Oscillator Amplifier. The crystal used with the ADV7282A must be a fundamental mode crystal. If an external 1.8 V, 28.63636 MHz clock oscillator source is used to clock the ADV7282A, the output of the oscillator is fed into the XTALN pin.                         |
| 16             | PVDD         | Power        | PLL Power Supply (1.8 V).  |
| 17, 18, 24, 25 | AIN1 to AIN4 | Input        | Analog Video Input Channels.   |
| 19             | VREFP        | Output       | Positive Internal Voltage Reference Output.  |
| 20             | VREFN        | Output       | Negative Internal Voltage Reference Output.  |
| 21             | AVDD         | Power        | Analog Power Supply (1.8 V).   |
| 22             | DIAG1        | Input        | Diagnostic Input 1.  |
| 23             | DIAG2        | Input        | Diagnostic Input 2.  |
| 26             | INTRQ        | Output       | Interrupt Request Output. An interrupt occurs when certain signals are detected on the input video.  |
| 27             | RESET        | Input        | System Reset Input (Active Low). A minimum low reset pulse width of 5 ms is required to reset the ADV7282A circuitry.  |
| 28             | ALSB         | Input        | Address Least Significant Bit. This pin selects the I <sup>2</sup> C write address for the ADV7282A. When ALSB is set to Logic 0, the write address is 0x40; when ALSB is set to Logic 1, the write address is 0x42.   |
| 29             | SDATA        | Input/output | I <sup>2</sup> C Port Serial Data Input/Output.  |
| 30             | SCLK         | Input        | I <sup>2</sup> C Port Serial Clock Input. The maximum clock rate is 400 kHz.   |
| 31             | PWRDWN       | Input        | Power-Down. A logic low on this pin places the ADV7282A in power-down mode.  |
| 32             | LLC          | Output       | Line Locked Clock for Output Pixel Data. The clock output is nominally 27 MHz, but it increases or decreases according to the video line length.   |
|                | EPAD (EP)    |              | Exposed Ground Pad. The exposed pad must be connected, together with the DGND pins, to a common ground plane (GND).  |

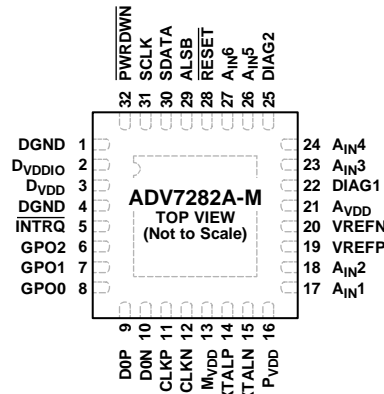

NOTES  
 1. THE EXPOSED PAD MUST BE CONNECTED, TOGETHER WITH THE DGND PINS, TO A COMMON GROUND PLANE (GND).

16148-007

Figure 7. Pin Configuration, ADV7282A-M

Table 10. Pin Function Descriptions, ADV7282A-M

| Pin No.                | Mnemonic                             | Type         | Description  |
|------------------------|--------------------------------------|--------------|--|
| 1, 4                   | DGND                                 | Ground       | Ground for Digital Supply.   |
| 2                      | D <sub>VDDIO</sub>                   | Power        | Digital I/O Power Supply (3.3 V).  |
| 3                      | D <sub>VDD</sub>                     | Power        | Digital Power Supply (1.8 V).  |
| 5                      | INTRQ                                | Output       | Interrupt Request Output. An interrupt occurs when certain signals are detected on the input video.  |
| 6 to 8                 | GPO2 to GPO0                         | Output       | General-Purpose Outputs. These pins can be configured via I <sup>2</sup> C to allow control of external devices.   |
| 9                      | DOP                                  | Output       | Positive MIPI Differential Data Output.  |
| 10                     | DON                                  | Output       | Negative MIPI Differential Data Output.  |
| 11                     | CLKP                                 | Output       | Positive MIPI Differential Clock Output.   |
| 12                     | CLKN                                 | Output       | Negative MIPI Differential Clock Output.   |
| 13                     | M <sub>VDD</sub>                     | Power        | MIPI Digital Power Supply (1.8 V).   |
| 14                     | XTALP                                | Output       | Output Pin for the Crystal Oscillator Amplifier. Connect this pin to the external 28.63636 MHz crystal, or leave it unconnected if an external 1.8 V, 28.63636 MHz clock oscillator source is used to clock the ADV7282A-M. The crystal used with the ADV7282A-M must be a fundamental mode crystal. |
| 15                     | XTALN                                | Input        | Input Pin for the Crystal Oscillator Amplifier. The crystal used with the ADV7282A-M must be a fundamental mode crystal. If an external 1.8 V, 28.63636 MHz clock oscillator source is used to clock the ADV7282A-M, the output of the oscillator is fed into the XTALN pin.                         |
| 16                     | P <sub>VDD</sub>                     | Power        | PLL Power Supply (1.8 V).  |
| 17, 18, 23, 24, 26, 27 | A <sub>IN1</sub> to A <sub>IN6</sub> | Input        | Analog Video Input Channels.   |
| 19                     | VREFP                                | Output       | Positive Internal Voltage Reference Output.  |
| 20                     | VREFN                                | Output       | Negative Internal Voltage Reference Output.  |
| 21                     | A <sub>VDD</sub>                     | Power        | Analog Power Supply (1.8 V).   |
| 22                     | DIAG1                                | Input        | Diagnostic Input 1.  |
| 25                     | DIAG2                                | Input        | Diagnostic Input 2.  |
| 28                     | RESET                                | Input        | System Reset Input (Active Low). A minimum low reset pulse width of 5 ms is required to reset the ADV7282A-M circuitry.  |
| 29                     | ALSB                                 | Input        | Address Least Significant Bit. This pin selects the I <sup>2</sup> C write address for the ADV7282A-M. When ALSB is set to Logic 0, the write address is 0x40; when ALSB is set to Logic 1, the write address is 0x42.   |
| 30                     | SDATA                                | Input/output | I <sup>2</sup> C Port Serial Data Input/Output.  |
| 31                     | SCLK                                 | Input        | I <sup>2</sup> C Port Serial Clock Input. The maximum clock rate is 400 kHz.   |
| 32                     | PWRDWN                               | Input        | Power-Down. A logic low on this pin places the ADV7282A-M in power-down mode.  |
|                        | EPAD (EP)                            |              | Exposed Ground Pad. The exposed pad must be connected, together with the DGND pins, to a common ground plane (GND).  |

## THEORY OF OPERATION

The ADV7282A is a versatile one-chip, multiformat video decoder that automatically detects standard analog baseband video signals and converts them into a YCbCr 4:2:2 component video data stream. The ADV7282A supports video signals compatible with worldwide NTSC, PAL, and SECAM standards.

The analog front ends of the ADV7282A feature an input mux (4-channel for ADV7282A, 6-channel for ADV7282A-M), a differential to single-ended converter and a single 10-bit ADC. The analog video inputs accept single-ended, pseudo differential, and fully differential composite video signals as well as S-Video (Y/C) and YPrPb video signals, supporting a wide range of automotive and consumer video sources.

The incoming analog video is converted into a digital 8-bit YCrCb 4:2:2 video stream that is output either via a digital 8-bit ITU-R BT.656 video stream (ADV7282A) or via a MIPI Tx interface (ADV7282A-M). External horizontal sync (HS), vertical sync (VS), and field sync signals are available for the ITU-R BT.656 interface to provide timing references for LCD controllers and other video ASICs.

The ADV7282A features an advanced I<sup>2</sup>P function to convert interlaced input video to a progressive video output with no requirement for external memory. The I<sup>2</sup>P conversion uses edge adaptive technology to minimize video defects on low angle lines.

The ac-coupled connection of input video signals to the ADV7282A provides STB protection; two diagnostic sense inputs are available. The ADV7282A also offers a dither mode, adaptive contrast enhancement (ACE) and general-purpose outputs (ADV7282A-M only).

The ADV7282A is programmed via a 2-wire, serial bidirectional port (I<sup>2</sup>C compatible) and can communicate with other devices via a hardware interrupt pin, INTRQ.

The ADV7282A is fabricated in a low power 1.8 V CMOS process and are provided in a space-saving LFCSP surface-mount, RoHS compliant package.

The ADV7282A is available in an automotive grade rated over the -40°C to +105°C temperature range, making them ideal for automotive applications.

### ANALOG FRONT END

The analog front end (AFE) of the ADV7282A is composed of an input mux, a differential to single-ended converter with clamp circuitry, a set of four antialiasing filters, and a single 10-bit ADC.

The input mux (4-channel for ADV7282A, 6-channel for ADV7282A-M) enables multiple composite video signals to be applied to the SDP and is software controlled.

The next stage in the AFE features the differential to single-ended converter and the clamp circuitry. The incorporation of a differential front end allows differential video to connect directly to the ADV7282A. The differential front end enables

small and large signal noise rejection, improved electromagnetic interference (EMI), and the ability to absorb ground bounce. The architecture can support true differential, pseudo differential, and single-ended signals.

In conjunction with an external resistor divider, the ADV7282A can provide a common-mode input range of 4 V, facilitating the removal of large signal, common-mode transients present on both video inputs.

The external resistor divider is required before each analog input channel to ensure that the input signal is kept within the range of the ADC. Current and voltage clamps in the circuit ensure that the video signal remains within the range on the ADC.

The single 10-bit ADC digitizes the analog video before it is applied to the SDP. Table 11 shows the three ADC clocking rates that are determined by the video input format to be processed. These clock rates ensure 4× oversampling per channel for CVBS, Y/C, and YPrPb modes.

**Table 11. ADC Clock Rates**

| Input Format               | ADC Clock Rate (MHz) <sup>1</sup> | Oversampling Rate per Channel |
|----------------------------|-----------------------------------|-------------------------------|
| CVBS                       | 57.27                             | 4×                            |
| S-Video (Y/C) <sup>2</sup> | 114                               | 4×                            |
| YPrPb <sup>2</sup>         | 172                               | 4×                            |

<sup>1</sup> Based on a 28.63636 MHz clock input to the ADV7282A.

<sup>2</sup> Configuration writes are required for the different S-Video (Y/C) and YPrPb modes.

### STANDARD DEFINITION PROCESSOR (SDP)

The SDP in the ADV7282A is capable of decoding a large selection of baseband video signals in composite (both single-ended and differential), S-Video (Y/C), and component formats. The video standards supported by the video processor include

- PAL B, PAL D, PAL G, PAL H, PAL I, PAL M, PAL N, PAL Nc, PAL 60
- NTSC J, NTSC M, NTSC 4.43
- SECAM B, SECAM D, SECAM G, SECAM K, SECAM L

The SDP in the ADV7282A can automatically detect the video standard and process it accordingly.

The ADV7282A has a five-line, superadaptive, 2D comb filter that provides superior chrominance and luminance separation when decoding a composite video signal. This highly adaptive filter automatically adjusts its processing mode according to the video standard and signal quality without requiring user intervention. Video user controls such as brightness, contrast, saturation, and hue are also available in the ADV7282A.

The ADV7282A implements a patented Adaptive Digital Line Length Tracking (ADLLT™) algorithm to track varying video line lengths from sources such as a VCR. ADLLT enables the ADV7282A to track and decode poor quality video sources such as VCRs and noisy sources from tuner outputs, VCD players, and

camcorders. The ADV7282A contains a chroma transient improvement (CTI) processor that sharpens the edge rate of chroma transitions, resulting in sharper vertical transitions.

The ADV7282A features an automatic gain control (AGC) algorithm to ensure that the optimum luma gain is selected as the input video varies in brightness.

ACE is an algorithm that automatically varies the contrast level applied across an image to enhance the picture detail visible. This automatic variation enables the contrast in the dark areas of an image to be increased without saturating the bright areas, which is particularly useful in automotive applications where it can be important to be able to clearly discern objects in shaded areas.

Downdithering from eight bits to six bits enables ease of design for standard LCD panels.

The SDP can handle a variety of vertical blanking interval (VBI) data services, such as closed captioning (CCAP), wide screen signaling (WSS), copy generation management system (CGMS), and teletext data slicing for world standard teletext (WST). Data is transmitted via the 8-bit video output port as ancillary data packets (ANC).

The ADV7282A is fully Rovi™ (formerly Macrovision® and now rebranded as TiVo upon acquisition of the same) compliant; detection circuitry enables Type I, Type II, and Type III protection levels to be identified and reported to the user. The SDP is fully robust to all Rovi signal inputs.

## POWER SUPPLY SEQUENCING

### OPTIMAL POWER-UP SEQUENCE

The optimal power-up sequence for the ADV7282A is guaranteed by production testing.

The optimal power-up sequence for the ADV7282A is to first power up the 3.3 V  $D_{VDDIO}$  supply, followed by the 1.8 V supplies:  $D_{VDD}$ ,  $P_{VDD}$ ,  $A_{VDD}$ , and  $M_{VDD}$  (for the ADV7282A-M).

When powering up the ADV7282A, follow these steps. During power-up, all supplies must adhere to the specifications listed in the Absolute Maximum Ratings section.

1. Assert the  $\overline{PWRDWN}$  and  $\overline{RESET}$  pins (pull the pins low).
2. Power up the  $D_{VDDIO}$  supply.
3. After  $D_{VDDIO}$  is fully asserted, power up the 1.8 V supplies.
4. After the 1.8 V supplies are fully asserted, pull the  $\overline{PWRDWN}$  pin high.
5. Wait 5 ms and then pull the  $\overline{RESET}$  pin high.
6. After all power supplies and the  $\overline{PWRDWN}$  and  $\overline{RESET}$  pins are powered up and stable, wait an additional 5 ms before initiating I<sup>2</sup>C communication with the ADV7282A-M.

### SIMPLIFIED POWER-UP SEQUENCE

The simplified power-up sequence is guaranteed by characterization.

Alternatively, the ADV7282A can be powered up by asserting all supplies and the  $\overline{PWRDWN}$  pin simultaneously. During this operation, the  $\overline{RESET}$  pin must remain low. After the supplies and  $\overline{PWRDWN}$  are fully asserted, wait for at least 5 ms before bringing the  $\overline{RESET}$  pin high. After the  $\overline{RESET}$  pin is fully asserted wait a further 5 ms before initiating I<sup>2</sup>C communication with the ADV7282A.

While the supplies are established, ensure that a lower rated supply does not go above a higher rated supply level. During power-up, all supplies must adhere to the specifications listed in the Absolute Maximum Ratings section.

### POWER-DOWN SEQUENCE

The ADV7282A supplies can be deasserted simultaneously if  $D_{VDDIO}$  does not go below a lower rated supply.

### $D_{VDDIO}$ SUPPLY VOLTAGE

For correct operation of the ADV7282A-M, the  $D_{VDDIO}$  supply must be from 2.97 V to 3.63 V.

The ADV7282A, however, can operate with a nominal  $D_{VDDIO}$  voltage of 1.8 V. In this case, apply the power-up sequences described in the Optimal Power-Up Sequence section. The only change is that  $D_{VDDIO}$  is powered up to 1.8 V instead of 3.3 V, and the  $\overline{PWRDWN}$  and  $\overline{RESET}$  pins of the ADV7282A are powered up to 1.8 V instead of 3.3 V.

When the ADV7282A operates with a nominal  $D_{VDDIO}$  voltage of 1.8 V, set the drive strength of all digital outputs to the maximum values.

When  $D_{VDDIO}$  is 1.8 V, do not pull any pin of the ADV7282A up to 3.3 V. For example, the I<sup>2</sup>C pins of the ADV7282A (SCLK and SDATA) must also be pulled up to 1.8 V instead of 3.3 V.

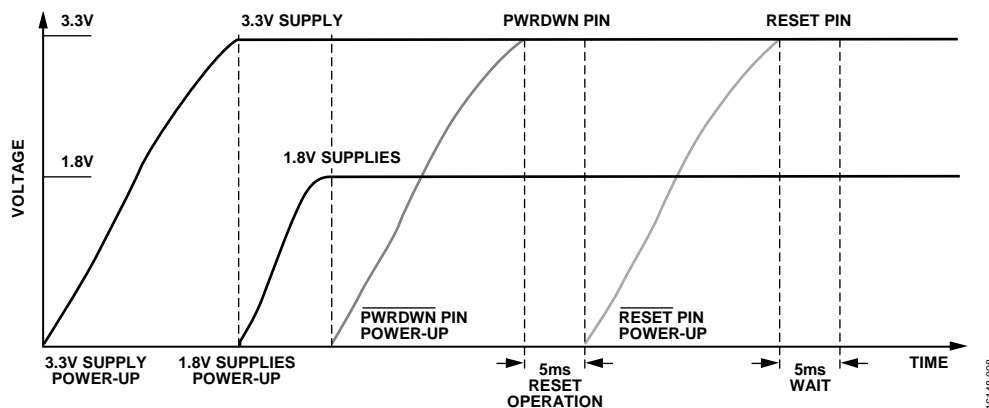

Figure 8. Optimal Power-Up Sequence

## CRYSTAL OSCILLATOR DESIGN

The ADV7282A needs a stable and accurate clock source to guarantee their operation. This clock is typically provided by a crystal resonator (XTAL) but can also be provided by a clock oscillator.

The required circuitry for an XTAL is illustrated in Figure 18 and Figure 19. A damping resistor ( $R_{DAMP}$ ) is required on the output of the ADV7282A XTAL amplifier (XTALP). The purpose of this damping resistor is to limit the current flowing through the XTAL and to limit the voltage across the XTAL amplifier. To define the appropriate value of the damping resistor  $R_{DAMP}$  (see the Typical Circuit Connections section), consult the accompanying calculator tool (visit the design resources section at [www.analog.com/ADV7282A](http://www.analog.com/ADV7282A) to download).

The other components in the XTAL circuit must be chosen carefully, for example, incorrectly selected load capacitors may result in an offset to the crystal oscillation frequency. For more information on such considerations, see the [AN-1260 Application Note](#), *Crystal Design Considerations for Video Decoders, HDMI Receivers, and Transceivers*. After the XTAL circuit is defined, it is recommended to consult with the XTAL vendor to ensure that the design operates with sufficient margin across all conditions.

The evaluation of the ADV7282A was completed using an XTAL with typical characteristics (see Table 12).

**Table 12. Reference XTAL Characteristics**

| Characteristic                            | Value                       | Unit     |
|---|-----------------------------|----------|
| Package                                   | $3.2 \times 2.5 \times 0.8$ | mm       |
| Nominal Frequency                         | 28.63636                    | MHz      |
| Mode of Oscillation                       | Fundamental                 |          |
| Frequency Calibration (at 25°C)           | $\pm 20$                    | ppm      |
| Frequency Temperature Stability Tolerance | $\pm 50$                    | ppm      |
| Operating Temperature Range               | -40 to +125                 | °C       |
| Maximum Equivalent Series Resistance      | 25                          | $\Omega$ |
| Load Capacitance                          | 12                          | pF       |
| Drive Level                               | 200                         | $\mu W$  |
| Shunt Capacitance (Maximum)               | 5                           | pF       |
| Aging per Year                            | $\pm 3$                     | ppm      |

The values in Table 12 are provided for reference only. It is recommended to characterize the operation of the XTAL circuit thoroughly across the operating temperature range of the application, in conjunction with the XTAL vendor, prior to releasing any new design.



## INPUT NETWORKS

An input network (external resistor and capacitor circuit) is required on the  $A_{INX}$  input pins of the ADV7282A. The components of the input network depend on the video format selected for the analog input.

### SINGLE-ENDED INPUT NETWORK

Figure 9 shows the input network to use on each  $A_{INX}$  input pin of the ADV7282A when using any of the following video input formats:

- Single-ended CVBS
- YC (S-Video)
- YPrPb

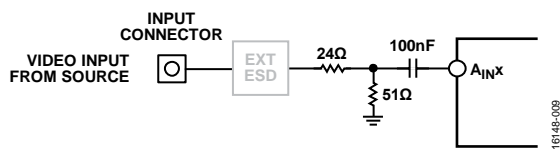

Figure 9. Single-Ended Input Network

The 24  $\Omega$  and 51  $\Omega$  resistors supply the 75  $\Omega$  end termination required for the analog video input. These resistors also create a resistor divider with a gain of 0.68. The resistor divider attenuates the amplitude of the input analog video and scales the input to the ADC range of the ADV7282A. This resistor divider allows an input range to the ADV7282A of up to 1.47 V p-p. Amplifiers within the ADC restore the amplitude of the input signal so that SNR performance is maintained.

The 100 nF ac coupling capacitor removes the dc bias of the analog input video before it is fed into an  $A_{INX}$  pin. The clamping circuitry within the ADV7282A restores the dc bias of the input signal to the optimal level before it is fed into the ADC of the ADV7282A.

### DIFFERENTIAL INPUT NETWORK

Figure 10 shows the input network to use when differential CVBS video is input on the  $A_{INX}$  input pins of the ADV7282A.

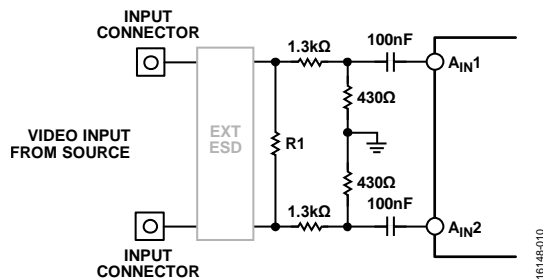

Figure 10. Differential Input Network

Fully differential video transmission involves transmitting two complementary CVBS signals. Pseudo differential video transmission involves transmitting a CVBS signal and a source ground signal.

Differential video transmission has several key advantages over single-ended transmission, including the following:

- Inherent small signal and large signal noise rejection
- Improved EMI performance
- Ability to absorb ground bounce

Resistor R1 provides the radio frequency (RF) end termination for the differential CVBS input lines. For a pseudo differential CVBS input, a value of 75  $\Omega$  is recommended for R1. For a fully differential CVBS input, a value of 150  $\Omega$  is recommended for R1.

The 1.3 k $\Omega$  and 430  $\Omega$  resistors create a resistor divider with a gain of 0.25. The resistor divider attenuates the amplitude of the input analog video, but increases the input common-mode range of the ADV7282A to 4 V p-p. Amplifiers within the ADC restore the amplitude of the input signal to maintain SNR performance.

The 100 nF ac coupling capacitor removes the dc bias of the analog input video before it is fed into an  $A_{INX}$  pin of the ADV7282A. The clamping circuitry within the ADV7282A restores the dc bias of the input signal to the optimal level before it is fed into the ADC of the ADV7282A.

The combination of the 1.3 k $\Omega$  and 430  $\Omega$  resistors and the 100 nF ac coupling capacitors limits the current flow into the ADV7282A during STB events (see the STB Protection section).

To achieve optimal performance, the 1.3 k $\Omega$  and 430  $\Omega$  resistors must be closely matched; that is, all 1.3 k $\Omega$  and 430  $\Omega$  resistors must have the same resistance tolerance, and this tolerance must be as low as possible.

### STB PROTECTION

In differential mode, the ADV7282A is protected against STB events by the external 100 nF ac coupling capacitors (see Figure 10). The external input network resistors are sized to be large enough to reduce the current flow during an STB event but small enough not to affect the operation of the ADV7282A.

The power rating of the input network resistors must be chosen to withstand the high voltages of STB events. Similarly, the breakdown voltage of the ac coupling capacitors must be chosen to be robust to STB events. The R1 resistor is protected because no current or limited current flows through it during an STB event.

The ADV7282A provides two STB diagnostic pins that generate an interrupt when an STB event occurs. For more information, see the STB Diagnostics section.

## APPLICATIONS INFORMATION

### INPUT CONFIGURATION

The input format of the ADV7282A is specified using the INSEL[4:0] bits (see Table 13). These bits also configure the SDP core to process CVBS, differential CVBS, S-Video (Y/C), or component (YPrPb) format. The INSEL[4:0] bits are located in the user sub map at Address 0x00, Bits[4:0]. For more information about the registers, see the Register Maps section.

The INSEL[4:0] bits specify predefined analog input routing schemes, eliminating the need for manual mux programming and allowing the user to route the various video signal types to the decoder. For example, if the CVBS input is selected, the remaining channels are powered down.

### STB DIAGNOSTICS

The ADV7282A senses an STB event via the DIAG1 and DIAG2 pins. The DIAG1 and DIAG2 pins can sense an STB event on either the positive or the negative differential input because of the negligible voltage drop across Resistor R1.

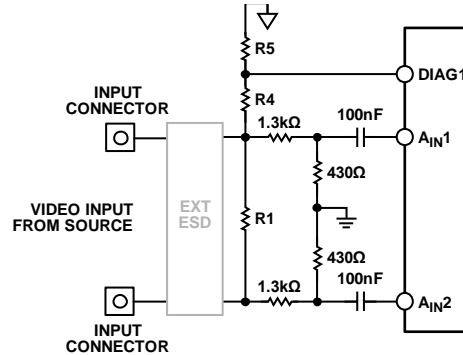

Figure 11. Diagnostic Connections

Resistors R4 and R5 divide down the voltage at the input connector to protect a DIAGx pin from an STB event. The DIAGx pin circuitry compares this voltage to a programmable reference voltage, known as the diagnostic slice level. When the diagnostic slice level is exceeded, an STB event occurs.

Table 13. Input Format Specified by the INSEL[4:0] Bits

| INSEL[4:0]<br>Bit Value | Video Format      | Analog Inputs   |   |
|-------------------------|-------------------|---|---|
|                         |                   | ADV7282A  | ADV7282A-M  |
| 00000                   | CVBS              | CVBS input on A <sub>IN1</sub>  | CVBS input on A <sub>IN1</sub>  |
| 00001                   | CVBS              | CVBS input on A <sub>IN2</sub>  | CVBS input on A <sub>IN2</sub>  |
| 00010                   | CVBS              | Reserved  | CVBS input on A <sub>IN3</sub>  |
| 00011                   | CVBS              | Reserved  | CVBS input on A <sub>IN4</sub>  |
| 00100                   | Reserved          | Reserved  | Reserved  |
| 00101                   | Reserved          | Reserved  | Reserved  |
| 00110                   | CVBS              | CVBS input on A <sub>IN3</sub>  | CVBS input on A <sub>IN5</sub>  |
| 00111                   | CVBS              | CVBS input on A <sub>IN4</sub>  | CVBS input on A <sub>IN6</sub>  |
| 01000                   | S-Video (Y/C)     | Y input on A <sub>IN1</sub> ; C input on A <sub>IN2</sub>               | Y input on A <sub>IN1</sub> ; C input on A <sub>IN2</sub>                                 |
| 01001                   | S-Video (Y/C)     | Reserved  | Y input on A <sub>IN3</sub> ; C input on A <sub>IN4</sub>                                 |
| 01010                   | Reserved          | Reserved  | Reserved  |
| 01011                   | S-Video (Y/C)     | Y input on A <sub>IN3</sub> ; C input on A <sub>IN4</sub>               | Y input on A <sub>IN5</sub> ; C input on A <sub>IN6</sub>                                 |
| 01100                   | YPrPb             | Reserved <sup>1</sup>   | Y input on A <sub>IN1</sub> ; Pb input on A <sub>IN2</sub> ; Pr input on A <sub>IN3</sub> |
| 01101                   | Reserved          | Reserved  | Reserved  |
| 01110                   | Differential CVBS | Positive input on A <sub>IN1</sub> ; negative input on A <sub>IN2</sub> | Positive input on A <sub>IN1</sub> ; negative input on A <sub>IN2</sub>                   |
| 01111                   | Differential CVBS | Reserved  | Positive input on A <sub>IN3</sub> ; negative input on A <sub>IN4</sub>                   |
| 10000                   | Reserved          | Reserved  | Reserved  |
| 10001                   | Differential CVBS | Positive input on A <sub>IN3</sub> ; negative input on A <sub>IN4</sub> | Positive input on A <sub>IN5</sub> ; negative input on A <sub>IN6</sub>                   |
| 10010 to 11111          | Reserved          | Reserved  | Reserved  |

<sup>1</sup> Note that it is possible for the ADV7282A to receive YPbPr formats; however, a manual muxing scheme is required. In this case luma (Y) is fed in on A<sub>IN1</sub> or A<sub>IN3</sub>, blue chroma (Pb) is fed in on A<sub>IN4</sub>, and red chroma (Pr) is fed in on A<sub>IN2</sub>.

When a DIAGx pin voltage exceeds the diagnostic slice level voltage, a hardware interrupt is triggered and indicated by the INTRQ pin. A readback register is also provided, allowing the user to determine the DIAGx pin on which the STB event occurred.

Use Equation 1 to find the trigger voltage for a selected diagnostic slice level.

$$V_{STB\_TRIGGER} = \frac{R5 + R4}{R5} \times DIAGNOSTIC\_SLICE\_LEVEL \quad (1)$$

where:

$V_{STB\_TRIGGER}$  is the minimum voltage required at the input connector to trigger the STB interrupt on the ADV7282A.  $DIAGNOSTIC\_SLICE\_LEVEL$  is the programmable reference voltage.

### PROGRAMMING THE STB DIAGNOSTIC FUNCTION

By default, the STB diagnostic function is disabled on the ADV7282A. To enable the diagnostic function, follow the instructions in this section.

#### DIAG1 Pin

**DIAG1\_SLICER\_PWRDN, Address 0x5D, Bit 6, User Sub Map**

This bit powers up or powers down the diagnostic circuitry for the DIAG1 pin.

**Table 14. DIAG1\_SLICER\_PWRDN Function**

| DIAG1_SLICER_PWRDN Setting | Diagnostic Slice Level                                 |
|----------------------------|--|
| 0                          | Power up the diagnostic circuitry for the DIAG1 pin.   |
| 1 (Default)                | Power down the diagnostic circuitry for the DIAG1 pin. |

**DIAG1\_SLICE\_LEVEL[2:0], Address 0x5D, Bits[4:2], User Sub Map**

The DIAG1\_SLICE\_LEVEL[2:0] bits allow the user to set the diagnostic slice level for the DIAG1 pin. When a voltage greater than the diagnostic slice level is seen on the DIAG1 pin, an STB interrupt is triggered.

For the diagnostic slice level to be set correctly, the diagnostic circuitry for the DIAG1 pin must be powered up (see Table 14).

**Table 15. DIAG1\_SLICE\_LEVEL[2:0] Settings**

| DIAG1_SLICE_LEVEL[2:0] Setting | Diagnostic Slice Level |
|--------------------------------|------------------------|
| 000                            | 75 mV                  |
| 001                            | 225 mV                 |
| 010                            | 375 mV                 |
| 011 (Default)                  | 525 mV                 |
| 100                            | 675 mV                 |
| 101                            | 825 mV                 |
| 110                            | 975 mV                 |
| 111                            | 1.125 V                |

#### DIAG2 Pin

**DIAG2\_SLICER\_PWRDN, Address 0x5E, Bit 6, User Sub Map**

This bit powers up or powers down the diagnostic circuitry for the DIAG2 pin.

**Table 16. DIAG2\_SLICER\_PWRDN Function**

| DIAG2_SLICER_PWRDN Setting | Diagnostic Slice Level                                 |
|----------------------------|--|
| 0                          | Power up the diagnostic circuitry for the DIAG2 pin.   |
| 1 (Default)                | Power down the diagnostic circuitry for the DIAG2 pin. |

**DIAG2\_SLICE\_LEVEL[2:0], Address 0x5E, Bits[4:2], User Sub Map**

The DIAG2\_SLICE\_LEVEL[2:0] bits allow the user to set the diagnostic slice level for the DIAG2 pin. When a voltage greater than the diagnostic slice level is seen on the DIAG2 pin, an STB interrupt is triggered.

For the diagnostic slice level to be set correctly, the diagnostic circuitry for the DIAG2 pin must be powered up (see Table 16).

**Table 17. DIAG2\_SLICE\_LEVEL[2:0] Settings**

| DIAG2_SLICE_LEVEL[2:0] Setting | Diagnostic Slice Level |
|--------------------------------|------------------------|
| 000                            | 75 mV                  |
| 001                            | 225 mV                 |
| 010                            | 375 mV                 |
| 011 (Default)                  | 525 mV                 |
| 100                            | 675 mV                 |
| 101                            | 825 mV                 |
| 110                            | 975 mV                 |
| 111                            | 1.125 V                |

**ADAPTIVE CONTRAST ENHANCEMENT (ACE)**

The ADV7282A can increase the contrast of an image depending on the content of the picture, brightening and darkening areas. The optional ACE feature enables the contrast within dark areas to increase without significantly affecting the bright areas. The ACE feature is particularly useful in automotive applications, where it can be important to discern objects in shaded areas.

The ACE function is disabled by default. To enable the ACE function, execute the register writes shown in Table 18. To disable the ACE function, execute the register writes shown in Table 19.

**I<sup>2</sup>P FUNCTION**

The advanced I<sup>2</sup>P function allows the ADV7282A to convert an interlaced video input into a progressive video output. This function is performed without the need for external memory. The ADV7282A uses edge adaptive technology to minimize video defects on low angle lines.

The I<sup>2</sup>P function is disabled by default. To enable the I<sup>2</sup>P function, use the recommended scripts from Analog Devices, Inc., available at [www.analog.com/ADV7282A](http://www.analog.com/ADV7282A).

**ITU-R BT.656 Tx CONFIGURATION (ADV7282A ONLY)**

The ADV7282A receives analog video and outputs digital video according to the ITU-R BT.656 specification. The ADV7282A outputs the ITU-R BT.656 video data stream over the P0 to P7 data pins and has an LLC pin.

Video data is output over the P0 to P7 pins in YCrCb 4:2:2 format. Synchronization signals are automatically embedded in the video data signal in accordance with the ITU-R BT.656 specification.

The LLC output clocks the output data on the P0 to P7 pins at a nominal frequency of 27 MHz.

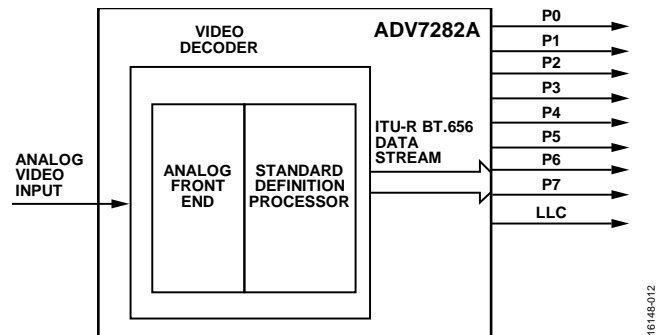

Figure 12. ITU-R BT.656 Output Stage of the ADV7282A

Table 18. Register Writes to Enable the ACE Function

| Register Map                  | Register Address | Register Write | Description          |
|-------------------------------|------------------|----------------|----------------------|
| User Sub Map (0x40 or 0x42)   | 0x0E             | 0x40           | Enter User Sub Map 2 |
| User Sub Map 2 (0x40 or 0x42) | 0x80             | 0x80           | Enable ACE           |
| User Sub Map 2 (0x40 or 0x42) | 0x0E             | 0x00           | Reenter user sub map |

Table 19. Register Writes to Disable the ACE Function

| Register Map                  | Register Address | Register Write | Description          |
|-------------------------------|------------------|----------------|----------------------|
| User Sub Map (0x40 or 0x42)   | 0x0E             | 0x40           | Enter User Sub Map 2 |
| User Sub Map 2 (0x40 or 0x42) | 0x80             | 0x00           | Disable ACE          |
| User Sub Map 2 (0x40 or 0x42) | 0x0E             | 0x00           | Reenter user sub map |

**MIPI Tx OUTPUT (ADV7282A-M ONLY)**

The decoder in the ADV7282A-M outputs an ITU-R BT.656 data stream. The ITU-R BT.656 data stream is connected into a CSI-2 Tx module. Data from the CSI-2 Tx module is fed into a D-PHY physical layer and output serially from the device.

The output of the ADV7282A-M consists of a single data channel on the D0P and D0N lanes and a clock channel on the CLKP and CLKN lanes.

Video data is output over the data lanes in high speed mode. The data lanes enter low power mode during the horizontal and vertical blanking periods.

The clock lanes clock the output video. After the ADV7282A-M is programmed, the clock lanes exit low power mode and remain in high speed mode until the device is reset or powered down.

The ADV7282A-M outputs video data in an 8-bit, YCrCb, 4:2:2 format. When the I<sup>2</sup>P core is disabled, the video data is output in an interlaced format at a nominal data rate of 216 Mbps. When the I<sup>2</sup>P core is enabled, the video data is output in a progressive format at a nominal data rate of 432 Mbps (see the I<sup>2</sup>P Function section for more information).

**I<sup>2</sup>C PORT DESCRIPTION**

The ADV7282A supports a 2-wire, I<sup>2</sup>C-compatible serial interface. Two inputs, serial data (SDATA) and serial clock (SCLK), carry information between the ADV7282A and the system I<sup>2</sup>C master controller. The I<sup>2</sup>C port of the ADV7282A allows the user to set up and configure the decoder and to read back captured VBI data.

The ADV7282A has a variety of possible I<sup>2</sup>C slave addresses and subaddresses (see the Register Maps section). The main map of the ADV7282A has four possible slave addresses for read and write operations, depending on the logic level of the ALSB pin (see Table 20).

**Table 20. Main Map I<sup>2</sup>C Addresses**

| ALSB Pin | R/W Bit | Slave Address |
|----------|---------|---------------|
| 0        | 0       | 0x40 (write)  |
| 0        | 1       | 0x41 (read)   |
| 1        | 0       | 0x42 (write)  |
| 1        | 1       | 0x43 (read)   |

The ALSB pin controls Bit 1 of the slave address. By changing the logic level of the ALSB pin, it is possible to control two ADV7282A devices in an application without using the same I<sup>2</sup>C slave address. The LSB (Bit 0) specifies either a read or write operation: Logic 1 corresponds to a read operation, and Logic 0 corresponds to a write operation.

To control the device on the bus, use the following protocol:

1. The master initiates a data transfer by establishing a start condition, defined as a high to low transition on SDATA while SCLK remains high, and indicates that an address/data stream follows.
2. All peripherals respond to the start condition and shift the next eight bits (the 7-bit address plus the R/W bit). The bits are transferred from MSB to LSB.
3. The peripheral that recognizes the transmitted address responds by pulling the data line low during the ninth clock pulse; this is known as an acknowledge (ACK) bit.
4. All other devices withdraw from the bus and maintain an idle condition. In the idle condition, the device monitors the SDATA and SCLK lines for the start condition and the correct transmitted address.

The R/W bit determines the direction of the data. Logic 0 on the LSB of the first byte means that the master writes information to the peripheral. Logic 1 on the LSB of the first byte means that the master reads information from the peripheral.

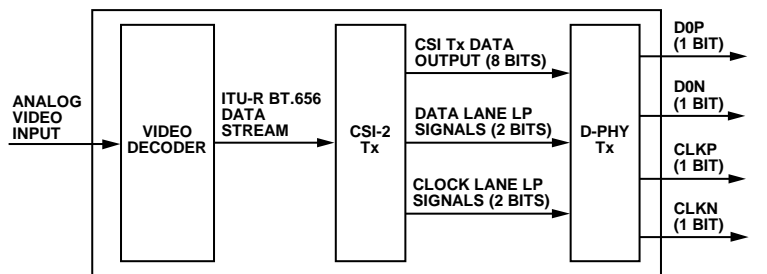

Figure 13. MIPI Tx Output Stage of the ADV7282A-M

The ADV7282A acts as standard I<sup>2</sup>C slave devices on the bus. The data on the SDATA pin is eight bits long, supporting the 7-bit address plus the R/W bit. The device has subaddresses to enable access to the internal registers; therefore, it interprets the first byte as the device address and the second byte as the starting subaddress. The subaddresses auto-increment, allowing data to be written to or read from the starting subaddress. A data transfer is always terminated by a stop condition. The user can also access any unique subaddress register individually without updating all the registers.

Stop and start conditions can be detected at any stage during the data transfer. If these conditions are asserted out of sequence with normal read and write operations, they cause an immediate jump to the idle condition. During a given SCLK high period, issue

only one start condition, one stop condition, or a single stop condition followed by a single start condition. If an invalid subaddress is issued by the user, the ADV7282A does not issue an acknowledge, and returns to the idle condition.

If the highest subaddress is exceeded in auto-increment mode, take one of the following actions:

- In read mode, the register contents of the highest subaddress continue to output until the master device issues a no acknowledge, indicating the end of a read. A no acknowledge condition occurs when the SDATA line is not pulled low on the ninth pulse.
- In write mode, the data for the invalid byte is not loaded into a subaddress register. A no acknowledge is issued by the ADV7282A, and the device returns to the idle condition.

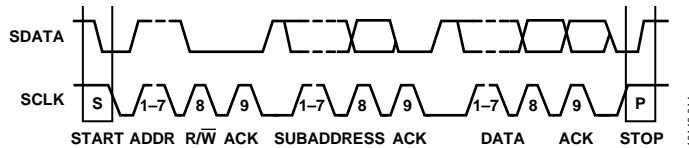

Figure 14. Bus Data Transfer

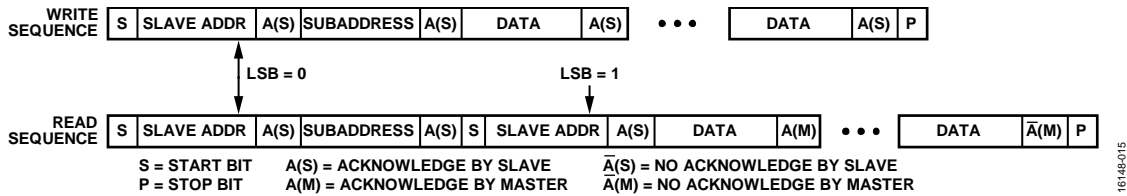

Figure 15. Read and Write Sequence

## REGISTER MAPS

The ADV7282A contains three register maps: the main register map, the video postprocessor (VPP) map, and the CSI map.

The main register map contains three sub maps: the user sub map, the interrupt/VDP sub map, and User Sub Map 2 (see Figure 16).

For more information about the ADV7282A registers, see the [ADV7280A/ADV7281A/ADV7282A Device Manual](#).

### Main Map

The I<sup>2</sup>C slave address of the main map of the ADV7282A is set by the ALSB pin (see Table 20). The main map allows the user to program the I<sup>2</sup>C slave addresses of the VPP and CSI maps. The three sub maps are accessed by writing to the SUB\_USR\_EN[1:0] bits (Address 0x0E, Bits[6:5]) within the user sub map (see Figure 16 and Table 21).

### User Sub Map

The user sub map contains registers that program the AFE and digital core of the ADV7282A. The user sub map has the same I<sup>2</sup>C slave address as the main map. To access the user sub map, set the SUB\_USR\_EN[1:0] bits in the user sub map (Address 0x0E, Bits[6:5]) to 00.

### Interrupt/VDP Sub Map

The interrupt/VDP sub map contains registers that program internal interrupts, control the  $\overline{\text{INTRQ}}$  pin, and decode VBI data.

The interrupt/VDP sub map has the same I<sup>2</sup>C slave address as the main map. To access the interrupt/VDP sub map, set the SUB\_USR\_EN[1:0] bits in the main map (Address 0x0E, Bits[6:5]) to 01.

### User Sub Map 2

User Sub Map 2 contains registers that control the ACE, down-dither, and fast lock functions. It also contains controls that set the acceptable input luma and chroma limits before the ADV7282A enters free run and color kill modes.

User Sub Map 2 has the same I<sup>2</sup>C slave address as the main map. To access User Sub Map 2, set the SUB\_USR\_EN[1:0] bits in the user sub map (Address 0x0E, Bits[6:5]) to 10.

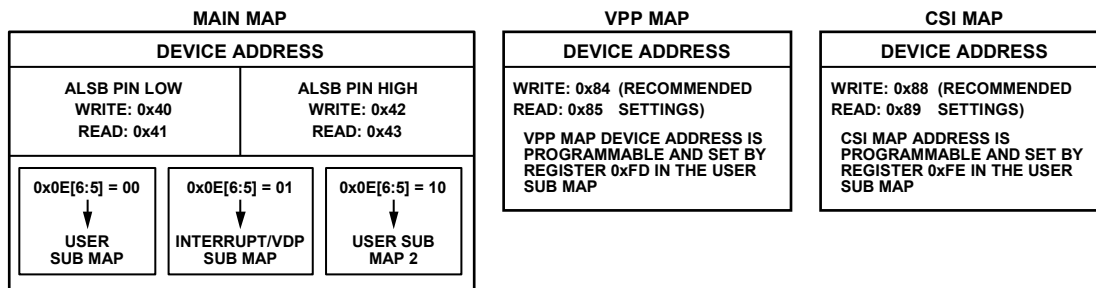

Figure 16. Register Map and Sub Map Access

Table 21. I<sup>2</sup>C Register Map and Sub Map Addresses

| ALSB Pin       | R/W Bit   | Slave Address | SUB_USR_EN[1:0] Bits (Address 0x0E, Bits[6:5]) | Register Map or Sub Map   |
|----------------|-----------|---------------|--|---------------------------|
| 0              | 0 (write) | 0x40          | 00   | User sub map              |
| 0              | 1 (read)  | 0x41          | 00   | User sub map              |
| 0              | 0 (write) | 0x40          | 01   | Interrupt/VDP sub map     |
| 0              | 1 (read)  | 0x41          | 01   | Interrupt/VDP sub map     |
| 0              | 0 (write) | 0x40          | 10   | User Sub Map 2            |
| 0              | 1 (read)  | 0x41          | 10   | User Sub Map 2            |
| 1              | 0 (write) | 0x42          | 00   | User sub map              |
| 1              | 1 (read)  | 0x43          | 00   | User sub map              |
| 1              | 0 (write) | 0x42          | 01   | Interrupt/VDP sub map     |
| 1              | 1 (read)  | 0x43          | 01   | Interrupt/VDP sub map     |
| 1              | 0 (write) | 0x42          | 10   | User Sub Map 2            |
| 1              | 1 (read)  | 0x43          | 10   | User Sub Map 2            |
| X <sup>1</sup> | 0 (write) | 0x84          | XX <sup>1</sup>                                | VPP map                   |
| X <sup>1</sup> | 1 (read)  | 0x85          | XX <sup>1</sup>                                | VPP map                   |
| X <sup>1</sup> | 0 (write) | 0x88          | XX <sup>1</sup>                                | CSI map (ADV7282A-M only) |
| X <sup>1</sup> | 1 (read)  | 0x89          | XX <sup>1</sup>                                | CSI map (ADV7282A-M only) |

<sup>1</sup> X and XX mean don't care.



**VPP Map**

The video postprocessor (VPP) map contains registers that control the I<sup>2</sup>P core (interlaced to progressive converter).

The VPP map has a programmable I<sup>2</sup>C slave address, which is programmed using Register 0xFD in the user sub map of the main map. The default value for the VPP map address is 0x00; however, the VPP map cannot be accessed until the I<sup>2</sup>C slave address is reset. The recommended I<sup>2</sup>C slave address for the VPP map is 0x84.

To reset the I<sup>2</sup>C slave address of the VPP map, write to the VPP\_SLAVE\_ADDR[7:1] bits in the main register map (Address 0xFD, Bits[7:1]). Set these bits to a value of 0x84 (I<sup>2</sup>C write address; I<sup>2</sup>C read address is 0x85).

**CSI Map (ADV7282A-M Only)**

The CSI map contains registers that control the MIPI Tx output stream from the ADV7282A-M.

The CSI map has a programmable I<sup>2</sup>C slave address, which is programmed using Register 0xFE in the user sub map. The default value for the CSI map address is 0x00; however, the CSI map cannot be accessed until the I<sup>2</sup>C slave address is reset. The recommended I<sup>2</sup>C slave address for the CSI map is 0x88.

To reset the I<sup>2</sup>C slave address of the CSI map, write to the CSI\_TX\_SLAVE\_ADDR[7:1] bits in the user sub map (Address 0xFE, Bits[7:1]). Set these bits to a value of 0x88 (I<sup>2</sup>C write address; I<sup>2</sup>C read address is 0x89).

**SUB\_USR\_EN[1:0] Bits, Address 0x0E, Bits[6:5]**

The user sub map is available by default. The other two sub maps are accessed using the SUB\_USR\_EN[1:0] bits. When programming of the interrupt/VDP map or User Sub Map 2 is completed, it is necessary to write to the SUB\_USR\_EN[1:0] bits to return to the user sub map.



## PCB LAYOUT RECOMMENDATIONS

The ADV7282A is a high precision, high speed, mixed-signal device. To achieve maximum performance from the device, it is important to use a well designed PCB. This section provides guidelines for designing a PCB for use with the ADV7282A.

### ANALOG INTERFACE INPUTS

When routing the analog interface inputs on the PCB, keep track lengths to a minimum. Use  $75\ \Omega$  trace impedances when possible; trace impedances other than  $75\ \Omega$  increase the chance of reflections.

### POWER SUPPLY DECOUPLING

It is recommended that each power supply pin be decoupled with 100 nF and 10 nF capacitors. The basic principle is to place a decoupling capacitor within approximately 0.5 cm of the  $P_{VDD}$ ,  $A_{VDD}$ ,  $D_{VDD}$ , and  $M_{VDD}$  pins. Avoid placing the decoupling capacitors on the opposite side of the PCB from the ADV7282A because doing so introduces inductive vias in the path.

Place the decoupling capacitors between the power plane and the power pin. Current flows from the power plane to the capacitor and then to the power pin. Do not apply the power connection between the capacitor and the power pin. The best approach is to place a via near, or beneath, the decoupling capacitor pads down to the power plane (see Figure 17).

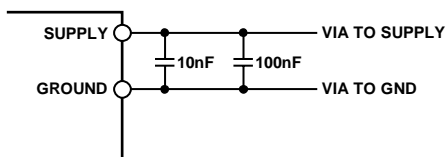

Figure 17. Recommended Power Supply Decoupling

Ensure that the power supplies connected to the ADV7282A,  $P_{VDD}$  and  $M_{VDD}$  ( $M_{VDD}$  only applies to the ADV7282A-M model) in particular, are well regulated and filtered. For optimum performance of the ADV7282A, it is recommended to isolate each supply and to use decoupling on each pin, located as physically close to the ADV7282A package as possible.

Some graphic controllers use substantially different levels of power when active (during active picture time) and when idle (during horizontal and vertical sync periods). This disparity can result in a measurable change in the voltage supplied to the analog supply regulator, which can, in turn, produce changes in the regulated analog supply voltage. This problem can be mitigated by regulating the analog supply, or at least the  $P_{VDD}$  supply, from a different, cleaner power source, for example, from a 12 V supply.

Using a single ground plane for the entire board is also recommended. Experience has shown that the noise performance is the same or better with a single ground plane. Using multiple ground planes can be detrimental because each separate ground plane is smaller, and long ground loops can result.

### VREFN AND VREFP PINS

Place the circuit associated with the VREFN and VREFP pins as close as possible to the ADV7282A and on the same side of the PCB as the device.

### DIGITAL OUTPUTS

The ADV7282A digital outputs are  $\overline{\text{INTRQ}}$ , LLC, and P0 to P7. The ADV7282A-M digital outputs are  $\overline{\text{INTRQ}}$  and GPO0 to GPO2.

Minimize the trace length that the digital outputs must drive. Longer traces have higher capacitance, requiring more current and, in turn, causing more internal digital noise. Shorter traces reduce the possibility of reflections.

Adding a  $30\ \Omega$  to  $50\ \Omega$  series resistor can suppress reflections, reduce EMI, and reduce current spikes inside the ADV7282A. If using series resistors, place them as close as possible to the pins of the ADV7282A. However, try not to add vias or extra length to the output trace in an attempt to place the resistors closer.

If possible, limit the capacitance that each digital output must drive to less than 15 pF. This recommendation can be easily accommodated by keeping traces short and by connecting the outputs to only one device. Loading the outputs with excessive capacitance increases the current transients inside the ADV7282A, creating more digital noise on the power supplies.

### EXPOSED METAL PAD

The ADV7282A has an exposed metal pad on the bottom of the package. This pad must be soldered to ground. The exposed pad is used for proper heat dissipation, noise suppression, and mechanical strength.

### DIGITAL INPUTS

The digital inputs of the ADV7282A are designed to work with 1.8 V signals (3.3 V for  $D_{VDDIO}$ ) and are not tolerant of 5 V signals. Extra components are required if 5 V logic signals must be applied to the decoder.

### MIPI Tx OUTPUTS (ADV7282A-M ONLY)

It is recommended that the MIPI Tx output traces be kept as short as possible and on the same side of the PCB as the ADV7282A-M device. It is also recommended that a solid plane (preferably a ground plane) be placed on the layer adjacent to the MIPI Tx traces to provide a solid reference plane.

MIPI Tx transmission operates in both differential and single-ended modes. During high speed transmission, the pair of outputs operates in differential mode; in low power mode, the pair operates as two independent single-ended traces. Therefore, it is recommended that each output pair be routed as two loosely coupled  $50\ \Omega$  single-ended traces to reduce the risk of crosstalk between the two traces in low power mode.

### TYPICAL CIRCUIT CONNECTIONS

Figure 18 provides an example of how to connect the ADV7282A. Figure 19 provides an example of how to connect the ADV7282A-M.

For detailed schematics of the ADV7282A evaluation boards, visit the ADV7282A product page at [www.analog.com/ADV7282A](http://www.analog.com/ADV7282A).

See the XTAL data sheet (from the XTAL vendor), the [AN-1260 Application Note](#), and the calculator tool (visit the design resources section at [www.analog.com/ADV7282A](http://www.analog.com/ADV7282A) to download) for the correct values for C1, C2, and R<sub>DAMP</sub>.

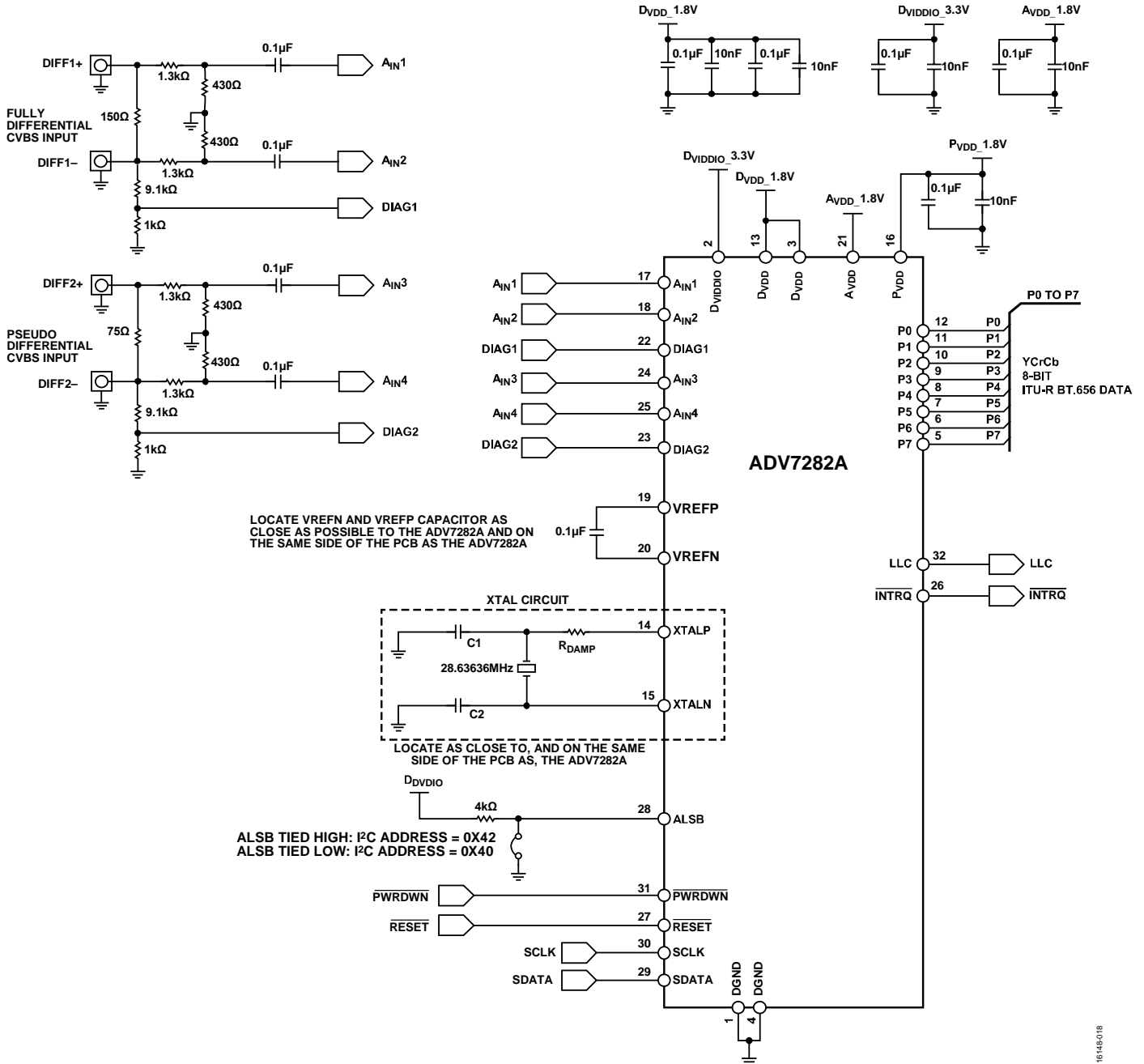

Figure 18. ADV7282A Typical Connection Diagram

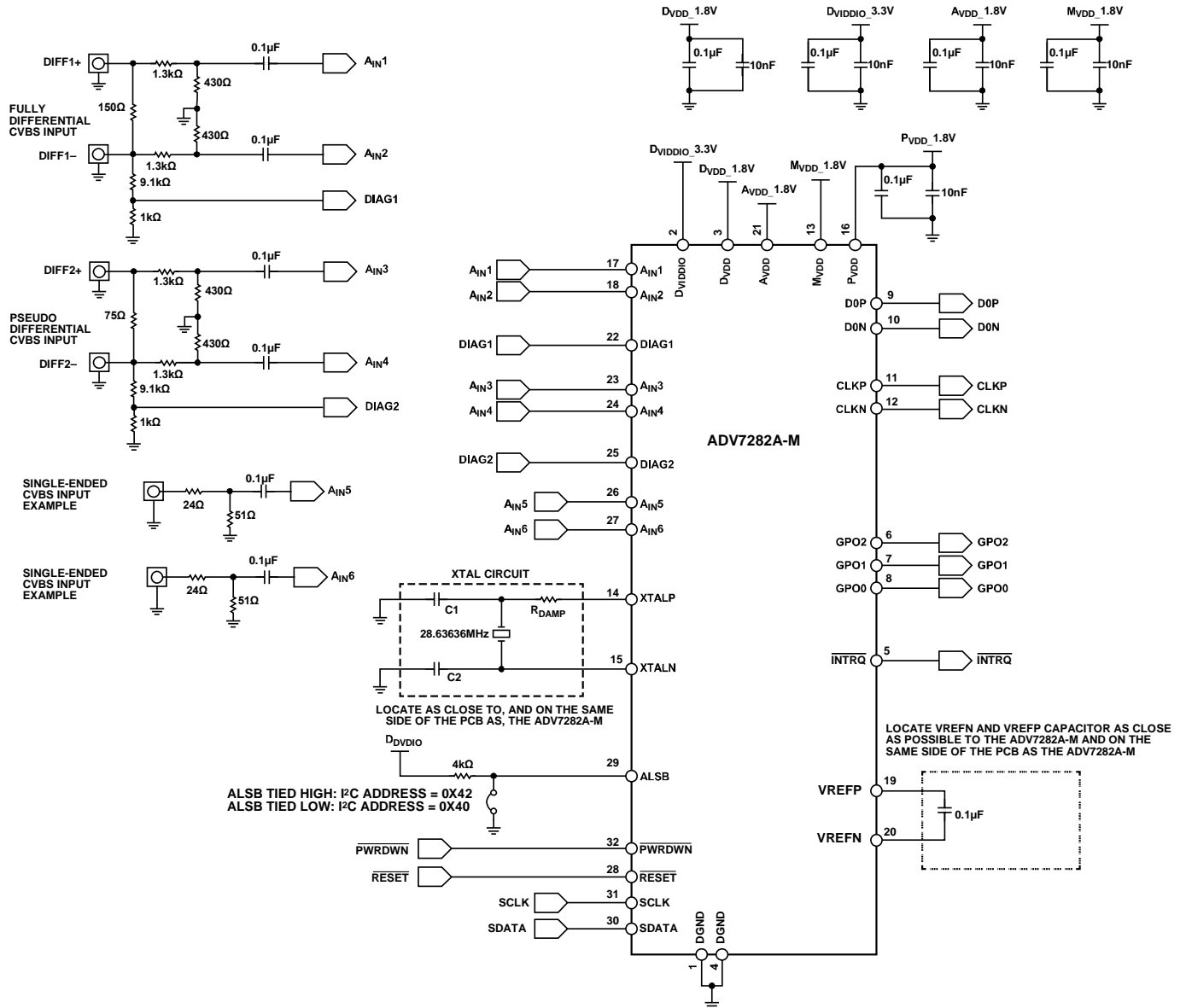
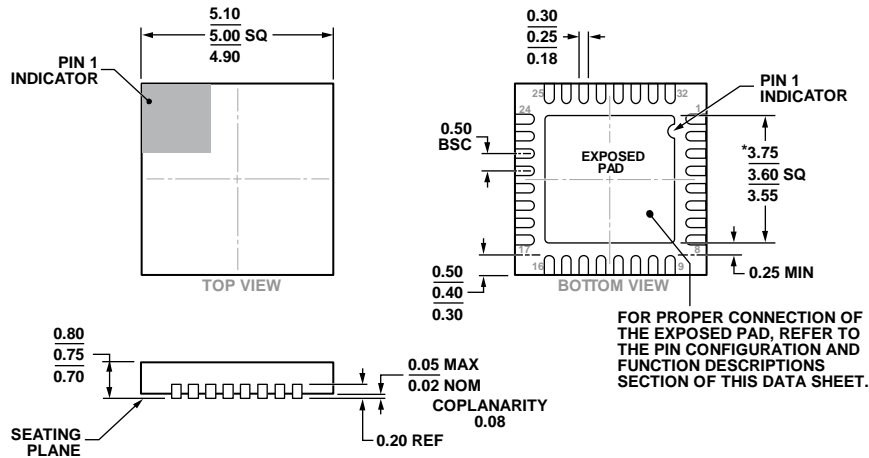

Figure 19. ADV7282A-M Typical Connection Diagram

16148019

OUTLINE DIMENSIONS



\*COMPLIANT TO JEDEC STANDARDS MO-220-WHHD-5 WITH THE EXCEPTION OF THE EXPOSED PAD DIMENSION.

Figure 20. 32-Lead Lead Frame Chip Scale Package [LFCSP]  
5 mm × 5 mm Body and 0.75 mm Package Height  
(CP-32-12)  
Dimensions shown in millimeters

06-16-2010-B

ORDERING GUIDE

| Model <sup>1, 2</sup> | Temperature Range | Package Description                           | Package Option |
|-----------------------|-------------------|---|----------------|
| ADV7282AWBCPZ         | -40°C to +105°C   | 32-Lead Lead Frame Chip Scale Package [LFCSP] | CP-32-12       |
| ADV7282AWBCPZ-RL      | -40°C to +105°C   | 32-Lead Lead Frame Chip Scale Package [LFCSP] | CP-32-12       |
| ADV7282AWBCPZ-M       | -40°C to +105°C   | 32-Lead Lead Frame Chip Scale Package [LFCSP] | CP-32-12       |
| ADV7282AWBCPZ-M-RL    | -40°C to +105°C   | 32-Lead Lead Frame Chip Scale Package [LFCSP] | CP-32-12       |
| EVAL-ADV7282AEBZ      |                   | Evaluation Board for the ADV7282A             |                |
| EVAL-ADV7282AMEBZ     |                   | Evaluation Board for the ADV7282A-M           |                |

<sup>1</sup> Z = RoHS Compliant Part.  
<sup>2</sup> W = Qualified for Automotive Applications.

AUTOMOTIVE PRODUCTS

The ADV7282AW models are available with controlled manufacturing to support the quality and reliability requirements of automotive applications. Note that these automotive models may have specifications that differ from the commercial models; therefore, designers should review the Specifications section of this data sheet carefully. Only the automotive grade products shown are available for use in automotive applications. Contact your local Analog Devices account representative for specific product ordering information and to obtain the specific Automotive Reliability reports for these models.

<sup>1</sup>C refers to a communications protocol originally developed by Philips Semiconductors (now NXP Semiconductors).

Компания «Life Electronics» занимается поставками электронных компонентов импортного и отечественного производства от производителей и со складов крупных дистрибьюторов Европы, Америки и Азии.

С конца 2013 года компания активно расширяет линейку поставок компонентов по направлению коаксиальный кабель, кварцевые генераторы и конденсаторы (керамические, пленочные, электролитические), за счёт заключения дистрибьюторских договоров

Мы предлагаем:

- Конкурентоспособные цены и скидки постоянным клиентам.
- Специальные условия для постоянных клиентов.
- Подбор аналогов.
- Поставку компонентов в любых объемах, удовлетворяющих вашим потребностям.
- Приемлемые сроки поставки, возможна ускоренная поставка.
- Доставку товара в любую точку России и стран СНГ.
- Комплексную поставку.
- Работу по проектам и поставку образцов.
- Формирование склада под заказчика.
- Сертификаты соответствия на поставляемую продукцию (по желанию клиента).
- Тестирование поставляемой продукции.
- Поставку компонентов, требующих военную и космическую приемку.
- Входной контроль качества.
- Наличие сертификата ISO.

В составе нашей компании организован Конструкторский отдел, призванный помогать разработчикам, и инженерам.

Конструкторский отдел помогает осуществить:

- Регистрацию проекта у производителя компонентов.
- Техническую поддержку проекта.
- Защиту от снятия компонента с производства.
- Оценку стоимости проекта по компонентам.
- Изготовление тестовой платы монтаж и пусконаладочные работы.



Тел: +7 (812) 336 43 04 (многоканальный)  
Email: [org@lifeelectronics.ru](mailto:org@lifeelectronics.ru)