

Description

The 651S is a low cost, high-speed single input to four output clock buffer. The 651S has best in class Additive Phase Jitter of sub 50fsec.

IDT makes many non-PLL and PLL based low skew output devices as well as Zero Delay Buffers to synchronize clocks. Contact IDT for all of your clocking needs.

Features

- Low additive phase jitter RMS: 50fs
- Extremely low skew outputs (50ps)
- Low cost clock buffer
- Packaged in 8-pin SOIC and 8-pin DFN, Pb-free
- Input/Output clock frequency up to 200 MHz
- Non-inverting output clock
- Ideal for networking clocks
- Operating Voltages: 1.8V to 3.3V
- Output Enable mode tri-states outputs
- Advanced, low power CMOS process
- Extended temperature range (-40°C to +105°C)

Block Diagram

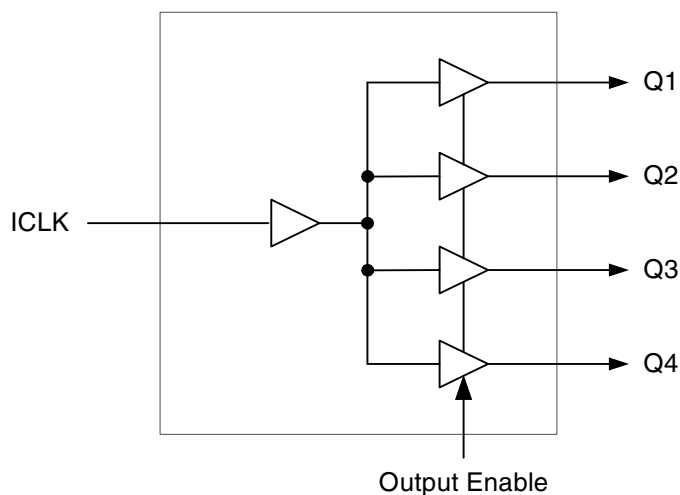

Pin Assignment

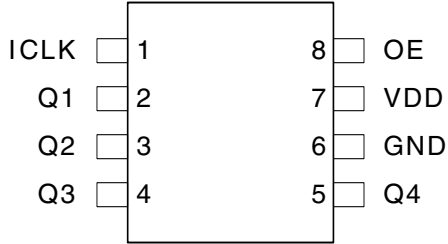

8 Pin (150 mil) SOIC

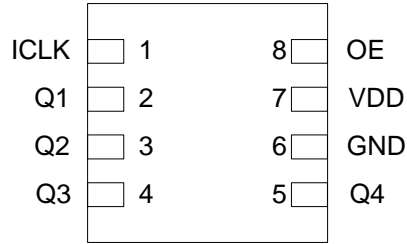

8-pin DFN

Pin Descriptions

Pin Number	Pin Name	Pin Type	Pin Description
1	ICLK	Input	Clock input. Internal pull-up resistor.
2	Q1	Output	Clock output 1.
3	Q2	Output	Clock output 2.
4	Q3	Output	Clock output 3.
5	Q4	Output	Clock output 4.
6	GND	Power	Connect to ground.
7	VDD	Power	Connect +1.8V, +2.5V or +3.3V.
8	OE	Input	Output Enable. Tri-states outputs when low. Internal pull-up resistor.

External Components

A minimum number of external components are required for proper operation. A decoupling capacitor of 0.01 μ F should be connected between VDD on pin 7 and GND on pin 6, as close to the device as possible. A 33 Ω series terminating resistor may be used on each clock output if the trace is longer than 1 inch.

Absolute Maximum Ratings

Stresses above the ratings listed below can cause permanent damage to the 651S. These ratings, which are standard values for IDT commercially rated parts, are stress ratings only. Functional operation of the device at these or any other conditions above those indicated in the operational sections of the specifications is not implied. Exposure to absolute maximum rating conditions for extended periods can affect product reliability. Electrical parameters are guaranteed only over the recommended operating temperature range.

Item	Rating
Supply Voltage, VDD	3.465V
All Inputs and Outputs	-0.5 V to 3.465V
Ambient Operating Temperature, Extended	-40 to +105°C
Storage Temperature	-65 to +150°C
Junction Temperature	125°C
Soldering Temperature	260°C

Recommended Operation Conditions

Parameter	Min.	Typ.	Max.	Units
Ambient Operating Temperature, Extended	-40	–	+105	°C
Power Supply Voltage (measured in respect to GND)	+1.71		+3.465	V

DC Electrical Characteristics

VDD=1.8 V \pm 5%, Ambient temperature -40° to +105°C, unless stated otherwise

Parameter	Symbol	Conditions	Min.	Typ.	Max.	Units
Operating Voltage	VDD		1.71		1.89	V
Input High Voltage, ICLK	V _{IH}	Note 1	0.7xVDD		1.89	V
Input Low Voltage, ICLK	V _{IL}	Note 1			0.3xVDD	V
Input High Voltage, OE	V _{IH}		0.7xVDD		VDD	V
Input Low Voltage, OE	V _{IL}				0.3xVDD	V
Output High Voltage	V _{OH}	I _{OH} = -10 mA	1.3			V
Output Low Voltage	V _{OL}	I _{OL} = 10 mA			0.35	V
Operating Supply Current	IDD	No load, 135 MHz		13		mA
Nominal Output Impedance	Z _O			17		Ω
Input Capacitance	C _{IN}	OE pin		5		pF

Notes: 1. Nominal switching threshold is VDD/2.

VDD=2.5 V \pm 5%, Ambient temperature -40° to +105°C, unless stated otherwise

Parameter	Symbol	Conditions	Min.	Typ.	Max.	Units
Operating Voltage	VDD		2.375		2.625	V
Input High Voltage, ICLK	V _{IH}	Note 1	0.7xVDD		2.625	V
Input Low Voltage, ICLK	V _{IL}	Note 1			0.3xVDD	V
Input High Voltage, OE	V _{IH}		0.7xVDD		VDD	V
Input Low Voltage, OE	V _{IL}				0.3xVDD	V
Output High Voltage	V _{OH}	I _{OH} = -16 mA	2			V
Output Low Voltage	V _{OL}	I _{OL} = 16 mA			0.3	V
Operating Supply Current	IDD	No load, 135 MHz		18		mA
Nominal Output Impedance	Z _O			17		Ω
Input Capacitance	C _{IN}	OE pin		5		pF

Notes: 1. Nominal switching threshold is VDD/2.

VDD=3.3 V \pm 5%, Ambient temperature -40° to +105°C, unless stated otherwise

Parameter	Symbol	Conditions	Min.	Typ.	Max.	Units
Operating Voltage	VDD		3.135		3.465	V
Input High Voltage, ICLK	V _{IH}	Note 1	0.7xVDD		3.465	V
Input Low Voltage, ICLK	V _{IL}	Note 1			0.3xVDD	V
Input High Voltage, OE	V _{IH}		0.7xVDD		VDD	V
Input Low Voltage, OE	V _{IL}				0.3xVDD	V
Output High Voltage	V _{OH}	I _{OH} = -25 mA	2.2			V
Output Low Voltage	V _{OL}	I _{OL} = 25 mA			0.7	V
Operating Supply Current	IDD	No load, 135 MHz		22		mA
Nominal Output Impedance	Z _O			17		Ω
Input Capacitance	C _{IN}	OE pin		5		pF

Notes: 1. Nominal switching threshold is VDD/2.

AC Electrical Characteristics

VDD=1.8V ±5%, Ambient Temperature -40° to +105°C, unless stated otherwise

Parameter	Symbol	Conditions	Min.	Typ.	Max.	Units
Output Frequency		5pF load, Note 4			200	MHz
Output Clock Rise Time	t _{OR}	0.36 to 1.44 V		0.6	1.0	ns
Output Clock Fall Time	t _{OF}	1.44 to 0.36V		0.6	1.0	ns
Start-up Time	t _{START-UP}	Part start-up time for valid outputs after VDD ramp-up			2	ms
Propagation Delay		135 MHz, Note 1	1.5	2	4	ns
Buffer Additive Phase Jitter, RMS		125MHz, Integration range: 12kHz–20MHz			0.05	ps
Output to Output Skew		Rising edges at VDD/2, Note 2		50	65	ps
Output Enable Time	t _{EN}	CL ≤ 5pF			3	cycles
Output Disable Time	t _{DIS}	CL ≤ 5pF			3	cycles

VDD=2.5V ±5%, Ambient Temperature -40° to +105°C, unless stated otherwise

Parameter	Symbol	Conditions	Min.	Typ.	Max.	Units
Output Frequency		5pF load, Note 4			200	MHz
Output Clock Rise Time	t _{OR}	0.5 to 2.0V		0.6	1.0	ns
Output Clock Fall Time	t _{OF}	2.0 to 0.5V		0.6	1.0	ns
Start-up Time	t _{START-UP}	Part start-up time for valid outputs after VDD ramp-up			2	ms
Propagation Delay		135 MHz, Note 1	1.8	2.5	4.5	ns
Buffer Additive Phase Jitter, RMS		125MHz, Integration range: 12kHz–20MHz			0.05	ps
Output to Output Skew		Rising edges at VDD/2, Note 2		50	65	ps
Output Enable Time	t _{EN}	CL ≤ 5pF			3	cycles
Output Disable Time	t _{DIS}	CL ≤ 5pF			3	cycles

VDD=3.3 V ±5%, Ambient Temperature -40° to +105°C, unless stated otherwise

Parameter	Symbol	Conditions	Min.	Typ.	Max.	Units
Output Frequency		5pF load, Note 4			200	MHz
Output Clock Rise Time	t _{OR}	0.66 to 2.64V		0.6	1.0	ns
Output Clock Fall Time	t _{OF}	2.64 to 0.66V		0.6	1.0	ns
Start-up Time	t _{START-UP}	Part start-up time for valid outputs after VDD ramp-up			2	ms
Propagation Delay		135 MHz, Note 1	1.5	2	4	ns
Buffer Additive Phase Jitter, RMS		125MHz, Integration range: 12kHz–20MHz			0.05	ps
Output to Output Skew		Rising edges at VDD/2, Note 2		50	65	ps
Output Enable Time	t _{EN}	CL ≤ 5pF			3	cycles
Output Disable Time	t _{DIS}	CL ≤ 5pF			3	cycles

Notes:

1. With rail to rail input clock.
2. Between any 2 outputs with equal loading.
3. Duty cycle on outputs will match incoming clock duty cycle. Consult IDT for tight duty cycle clock generators.
4. With external series resistor of 33Ω positioned close to each output pin.

Phase Noise Plots

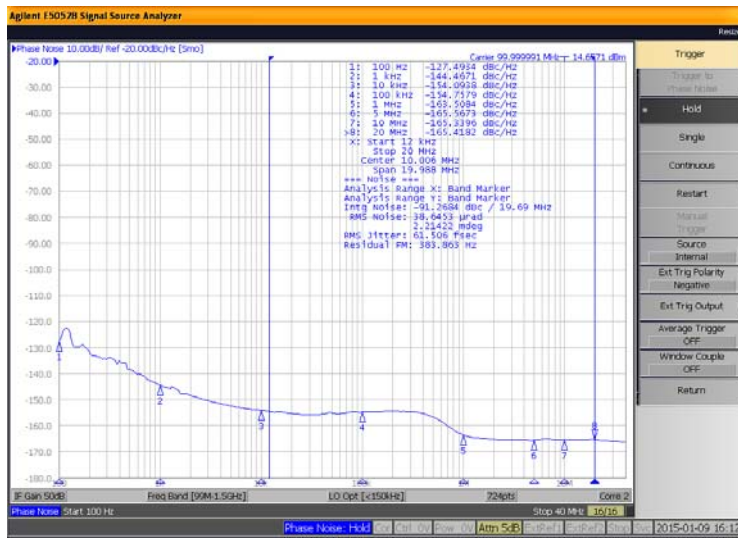

Figure 1. 651S Reference Phase Noise 62fs (12kHz to 20MHz)

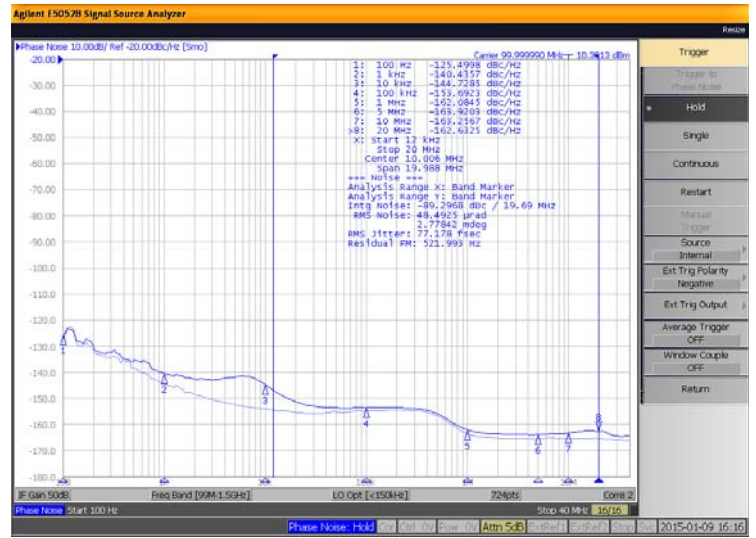
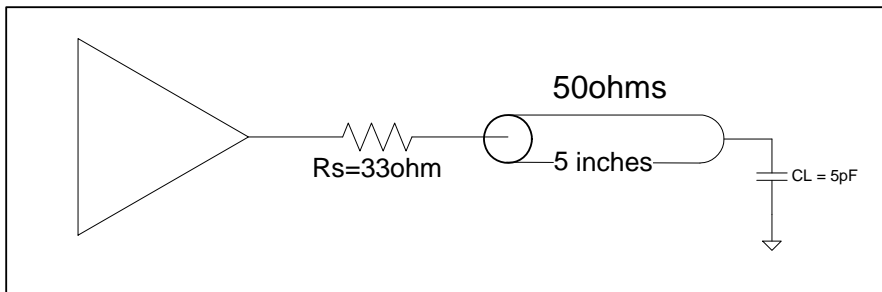

Figure 2. 651S Output Phase Noise 77fs (12kHz to 20MHz)

The phase noise plots above show the low Additive Jitter of the 651S high-performance buffer. With an integration range of 12kHz to 20MHz, the reference input has about 62fs of RMS phase jitter while the output of 651S has about 77fs of RMS phase jitter. This results in a low Additive Phase Jitter of only 45fs.

Test Load and Circuit



Thermal Characteristics (8SOIC)

Parameter	Symbol	Conditions	Min.	Typ.	Max.	Units
Thermal Resistance Junction to Ambient	θ_{JA}	Still air		150		°C/W
	θ_{JA}	1 m/s air flow		140		°C/W
	θ_{JA}	3 m/s air flow		120		°C/W
Thermal Resistance Junction to Case	θ_{JC}			40		°C/W

Marking Diagrams

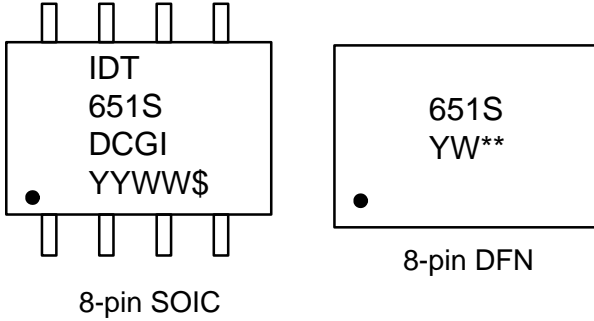

Notes:

1. “**” is the lot number.
2. “YYWW” or “YW” are the last digits of the year and week that the part was assembled.
- 3 “G” denotes RoHS compliant package.
4. “\$” denotes the mark code.
5. “I” denotes extended temperature range device.

Package Outline and Package Dimensions (8-pin DFN, 2mm x 2mm Body, 0.5mm pitch)

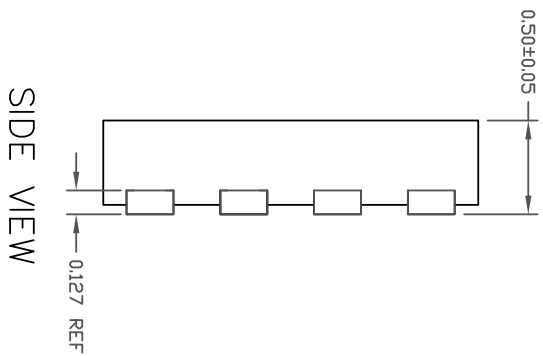
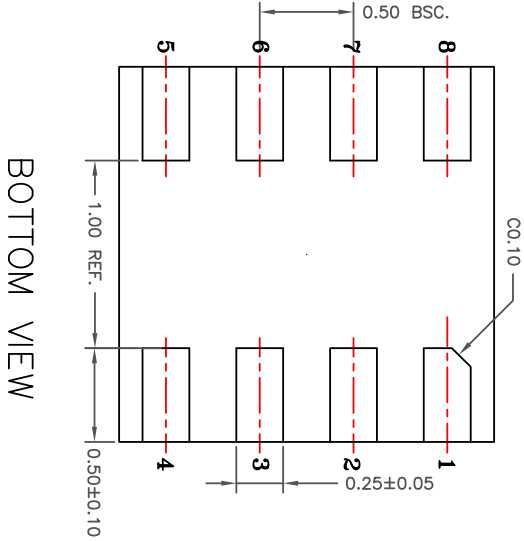
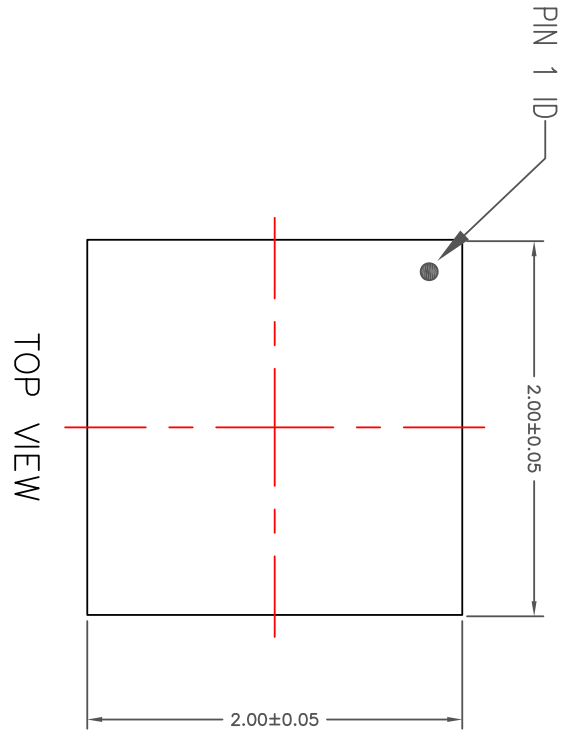

- NOTES:
1. ALL DIMENSIONING AND TOLERANCING CONFORM TO ANSI Y14.5M-1982
 2. ALL DIMENSIONS ARE IN MILLIMETERS

REVISIONS			
REV	DESCRIPTION	DATE	APPROVED
00	INITIAL RELEASE	09/18/14	JHUA

TOLERANCES UNLESS SPECIFIED DECIMAL ANGULAR XXX± XXX± XXX±		IDT 6024 SILVER CREEK VALLEY ROAD San Jose, CA 95138 PHONE: (408) 284-8200 FAX: (408) 492-8674 <small>www.idt.com</small>	
APPROVALS	DATE	TITLE	SIZE
DRWN: <i>gac</i>	09/10/14	2.0 X 2.0 mm BODY	C
CHEKED: <i>gac</i>	09/10/14	0.5mm PITCH VDFEN	DRAWING No.
			PSC-4490
			REV 00
DO NOT SCALE DRAWING			SHEET 1 OF 2

Package Outline and Package Dimensions, cont. (8-pin DFN, 2mm x 2mm Body, 0.5mm pitch)

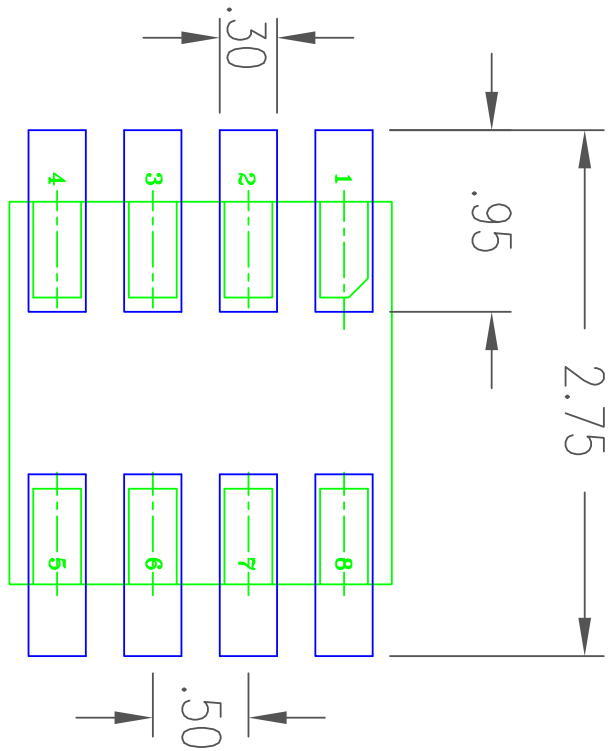

RECOMMENDED LAND PATTERN DIMENSION

NOTES:

1. ALL DIMENSION ARE IN mm. ANGLES IN DEGREES.
2. TOP DOWN VIEW. AS VIEWED.
3. COMPONENT OUTLINE SHOW FOR REFERENCE IN GREEN.
4. LAND PATTERN IN BLUE. NSMD PATTERN ASSUMED.
5. LAND PATTERN RECOMMENDATION PER IPC-7351B. GENERIC REQUIREMENT FOR MOUNT DESIGN AND LAND PATTERN.

REVISIONS		
REV	DESCRIPTION	DATE
00	INITIAL RELEASE	09/18/14

TOLERANCES UNLESS SPECIFIED		<p>6024 SILVER CREEK VALLE San Jose, CA 95138 PHONE: (408) 284-8200 FAX: (408) 492-8674</p>
DECIMAL	±	
ANGULAR	±	
XXX±	XXXX	
APPROVALS	DATE	TITLE
DRAWN	02/09/10/14	CM08 PACKAGE OUTLINE
CHECKED		2.0 X 2.0 mm BODY 0.5 mm PITCH VFOFN
SIZE	DRAWING No.	PSC-4490
C		
DO NOT SCALE DRAWING		SHEET

Package Outline and Package Dimensions (8-pin SOIC, 150 Mil. Narrow Body)

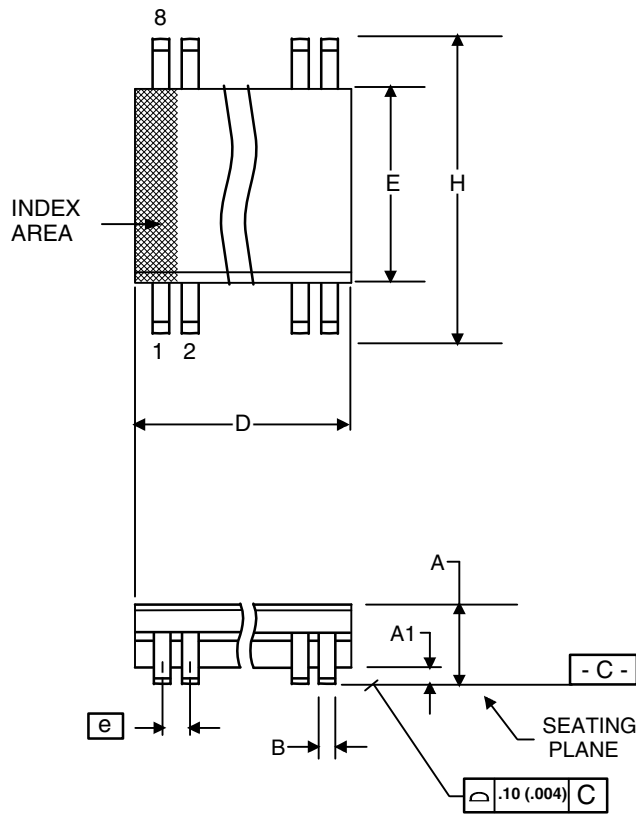

Symbol	Millimeters		Inches*	
	Min	Max	Min	Max
A	1.35	1.75	.0532	.0688
A1	0.10	0.25	.0040	.0098
B	0.33	0.51	.013	.020
C	0.19	0.25	.0075	.0098
D	4.80	5.00	.1890	.1968
E	3.80	4.00	.1497	.1574
e	1.27 BASIC		0.050 BASIC	
H	5.80	6.20	.2284	.2440
h	0.25	0.50	.010	.020
L	0.40	1.27	.016	.050
a	0°	8°	0°	8°

*For reference only. Controlling dimensions in mm.

Ordering Information

Part / Order Number	Marking	Shipping Packaging	Package	Temperature
651SDCGI	see page 7	Tubes	8-pin SOIC	-40 to +105 °C
651SDCGI8		Tape and Reel	8-pin SOIC	-40 to +105 °C
651SCMGI		Cut Tape	8-pin DFN	-40 to +105 °C
651SCMGI8		Tape and Reel	8-pin DFN	-40 to +105 °C

“G” suffix to the part number denotes Pb-Free configuration, RoHS compliant.

Revision History

Rev.	Date	Originator	Description of Change
A	03/18/15	B. Chandhoke	Initial release.



Corporate Headquarters
6024 Silver Creek Valley Road
San Jose, CA 95138 USA

Sales
1-800-345-7015 or 408-284-8200
Fax: 408-284-2775
www.IDT.com

Tech Support
email: clocks@idt.com

DISCLAIMER Integrated Device Technology, Inc. (IDT) and its subsidiaries reserve the right to modify the products and/or specifications described herein at any time and at IDT's sole discretion. All information in this document, including descriptions of product features and performance, is subject to change without notice. Performance specifications and the operating parameters of the described products are determined in the independent state and are not guaranteed to perform the same way when installed in customer products. The information contained herein is provided without representation or warranty of any kind, whether express or implied, including, but not limited to, the suitability of IDT's products for any particular purpose, an implied warranty of merchantability, or non-infringement of the intellectual property rights of others. This document is presented only as a guide and does not convey any license under intellectual property rights of IDT or any third parties.

IDT's products are not intended for use in applications involving extreme environmental conditions or in life support systems or similar devices where the failure or malfunction of an IDT product can be reasonably expected to significantly affect the health or safety of users. Anyone using an IDT product in such a manner does so at their own risk, absent an express, written agreement by IDT.

Integrated Device Technology, IDT and the IDT logo are registered trademarks of IDT. Product specification subject to change without notice. Other trademarks and service marks used herein, including protected names, logos and designs, are the property of IDT or their respective third party owners.

Copyright ©2015 Integrated Device Technology, Inc.. All rights reserved.

Компания «Life Electronics» занимается поставками электронных компонентов импортного и отечественного производства от производителей и со складов крупных дистрибьюторов Европы, Америки и Азии.

С конца 2013 года компания активно расширяет линейку поставок компонентов по направлению коаксиальный кабель, кварцевые генераторы и конденсаторы (керамические, пленочные, электролитические), за счёт заключения дистрибьюторских договоров

Мы предлагаем:

- Конкурентоспособные цены и скидки постоянным клиентам.
- Специальные условия для постоянных клиентов.
- Подбор аналогов.
- Поставку компонентов в любых объемах, удовлетворяющих вашим потребностям.
- Приемлемые сроки поставки, возможна ускоренная поставка.
- Доставку товара в любую точку России и стран СНГ.
- Комплексную поставку.
- Работу по проектам и поставку образцов.
- Формирование склада под заказчика.
- Сертификаты соответствия на поставляемую продукцию (по желанию клиента).
- Тестирование поставляемой продукции.
- Поставку компонентов, требующих военную и космическую приемку.
- Входной контроль качества.
- Наличие сертификата ISO.

В составе нашей компании организован Конструкторский отдел, призванный помогать разработчикам, и инженерам.

Конструкторский отдел помогает осуществить:

- Регистрацию проекта у производителя компонентов.
- Техническую поддержку проекта.
- Защиту от снятия компонента с производства.
- Оценку стоимости проекта по компонентам.
- Изготовление тестовой платы монтаж и пусконаладочные работы.



Тел: +7 (812) 336 43 04 (многоканальный)

Email: org@lifeelectronics.ru