

Aspherical Glass Lenses

Type: **EYLG**□□□□□□□□



These products are aspherical glass lenses by using a press molding, and key devices of optical electronics not only provide compact and light weight but also high-performance by utilizing characteristics of aspherical design.

Features

- High numerical aperture achieved via aspherical design
- Short focal length for compact size
- Appropriate lenses and lens material available for many different applications
- Wide temperature and humidity range for increased reliability and stability
- High-quality processing, measurement techniques and precision manufacturing process give less variation in optical properties
- RoHS compliant

* We can offer custom design, sampling and mass production as requested

Recommended Applications

- Coupling lens for optical communication systems
- Collimator lens for optical communication systems
- Lens for LD applications

Explanation of Part Numbers

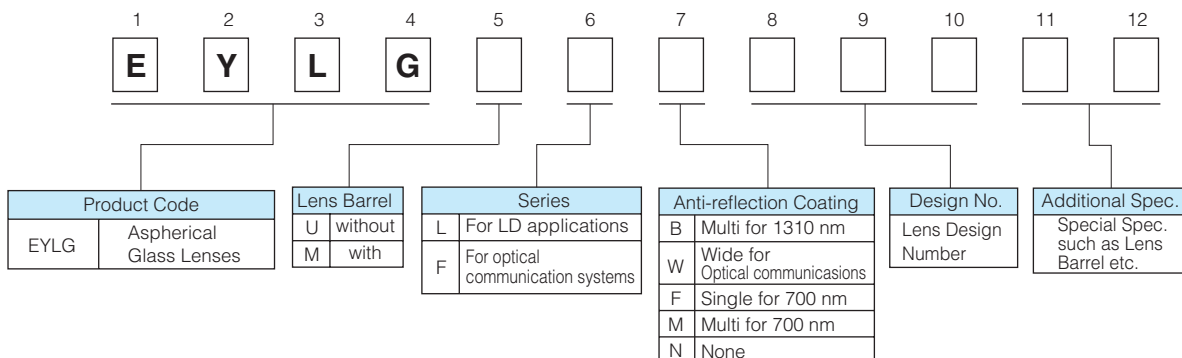

Ratings

Item	Ratings
Operating Temperature Range	-30 to +85 °C
Storage Temperature Range	-40 to +100 °C

■ Please contact the factory for packaging methods.

Specifications

● Lenses for Optical Communications

Part No.	Design Wavelength (nm)	Suitable Wavelength (T>97 %) (nm)	Designed with CG	Focal Length (mm)	Working Distance (* L1) (mm)	Conjugate Distance (* L2) (mm)	Magnification
			CG material / Thickness (mm)				
EYLGFW135DR	1550	1260 to 1625	–	2.51	1.68	–	–
EYLGFW192KR	1550	1260 to 1625	–	1.81	1.03	–	–
EYLGFW192WR	1550	1260 to 1625	–	1.81	0.81	–	–
EYLGFW265AR	1550	1260 to 1625	–	3.02	2.26	–	–
EYLGFW479A	1550	1260 to 1625	–	1.59	0.93	–	–
EYLGFB240BR	1310	1260 to 1625	–	1.40	1.13	10.69	5.0
EYLGFB456R	1310	1260 to 1625	–	0.54	0.25	3.85	4.5
EYLGFB508A	1310	1260 to 1625	–	0.55	0.25	3.98	5.3
EYLGFB506A	1310	1260 to 1625	–	0.63	0.52	4.00	4.0
EYLGFB245R	1310	1260 to 1625	BK7 t0.25	1.13	1.27*	7.50*	2.5
EYLGFB295R	1310	1260 to 1625	–	1.35	1.27*	10.18*	4.0
EYLGFB415R	1310	1260 to 1625	–	0.94	1.27*	7.56*	4.0
EYLGFB480A	1310	1260 to 1625	–	0.93	1.20*	5.73*	2.0
EYLGFB305R	1310	1260 to 1625	–	0.46	1.40*	3.90*	3.1
EYLGFB502B	1310	1260 to 1625	–	0.46	1.00*	3.50*	3.1
EYLGFB488A	1577	1260 to 1625	–	1.44	2.62*	12.02*	3.8
EYLGFB463R	1570	1260 to 1625	–	1.48	2.15*	12.10*	4.2
EYLGFB485A	1577	1260 to 1625	–	0.95	2.8*	8.20*	3.1

Part No.	N.A		Effective Diameter (mm)		Beam Diameter (mm)	Dimensions (mm)			Glass Material	Lens Shape type
	S1	S2	S1	S2		Diameter (D)	Height (H)	Thickness (T)		
EYLGFW135DR	–	0.20	1.04	0.80	0.50	2.5	1.4	–	K-PBK40	A-1
EYLGFW192KR	–	0.30	1.08	0.82	0.34	2.5	1.4	–	K-PBK40	A-1
EYLGFW192WR	–	0.30	1.08	0.73	0.36	3.0	1.6	–	K-PBK40	A-1
EYLGFW265AR	–	0.22	1.33	1.14	0.60	3.0	1.6	–	K-PBK40	A-1
EYLGFW479A	–	0.26	0.82	0.70	0.26	1.8	1.4	–	K-PBK40	A-1
EYLGFB240BR	0.50	0.10	1.31	1.70	–	3.0	1.5	–	K-VC89	A-2
EYLGFB456R	0.50	0.11	0.34	0.64	–	1.8	1.0	–	K-VC89	A-2
EYLGFB508A	0.58	0.11	0.40	0.70	–	1.0	–	0.81	K-VC79	D
EYLGFB506A	0.48	0.12	0.59	0.76	–	1.0	–	0.63	K-VC89	D
EYLGFB245R	0.40	0.16	0.90	1.20	–	3.75	3.97	–	K-VC89	B
EYLGFB295R	0.40	0.10	1.02	1.33	–	3.75	3.90	–	K-VC89	B
EYLGFB415R	0.50	0.13	0.76	1.14	–	3.75	3.50	–	K-VC89	B
EYLGFB480A	0.40	0.20	0.91	1.10	–	4.70	3.23	–	K-VC89	B
EYLGFB305R	0.50	0.16	0.34	0.52	–	3.20	2.45	–	K-VC89	B
EYLGFB502B	0.50	0.16	0.34	0.52	–	3.23	2.10	–	K-VC89	B
EYLGFB488A	0.60	0.16	1.40	2.20	–	5.00	5.90	–	K-VC89	B
EYLGFB463R	0.59	0.14	1.60	2.12	–	5.00	4.93	–	K-VC89	B
EYLGFB485A	0.53	0.17	1.00	1.30	–	4.90	5.00	–	K-VC89	B

Specifications

- Lenses for LD applications

Part No.	Design Wavelength (nm)	Suitable Wavelength (T>97 %) (nm)	Designed with CG	Focal Length (mm)	Working Distance (mm)	Magnification
			CG material / Thickness (mm)			
EYLGULM216	780	600 to 800	BK7 t0.25	10.00	8.85	∞
EYLGULF273	780	660 to 700	BK7 t0.30	12.50	10.93	∞
EYLGULF274	780	660 to 700	BK7 t0.25	6.25	4.84	∞
EYLGULF276	780	660 to 700	BK7 t0.25	8.00	6.60	∞
EYLGULF277	780	660 to 700	BK7 t0.30	8.98	7.72	∞
EYLGULF279	780	660 to 700	BK7 t0.30	4.00	2.66	∞
EYLGULF292	780	660 to 700 (T > 95 %)	BK7 t0.27	6.00	3.82	∞
EYLGULF319	780	660 to 700 (T > 95 %)	BK7 t0.25	12.50	11.12	∞
EYLGULM330	780	630 to 800	BK7 t0.25	3.59	2.55	∞

Part No.	N.A	Effective Diameter (mm)		Dimensions (mm)		Glass Material	Lens Shape type
	S1	S1	S2	Diameter (D)	Thickness (T)		
EYLGULM216	0.33	6.06	6.60	8.00	2.15	K-VC81	D
EYLGULF273	0.23	5.07	5.70	6.40	2.80	K-VC80	D
EYLGULF274	0.40	4.15	5.00	6.40	2.50	K-VC80	D
EYLGULF276	0.25	3.36	4.00	6.40	2.50	K-VC80	D
EYLGULF277	0.29	4.79	5.40	6.40	2.30	K-VC80	D
EYLGULF279	0.50	2.96	4.00	6.40	2.50	K-VC80	D
EYLGULF292	0.35	2.85	4.20	6.00	4.20	K-PBK40	D
EYLGULF319	0.23	5.20	5.70	8.00	2.50	K-PBK40	D
EYLGULM330	0.29	1.58	2.16	4.00	2.00	K-PBK40	D

Dimensions in mm (not to scale)

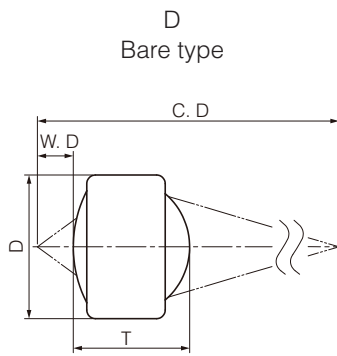
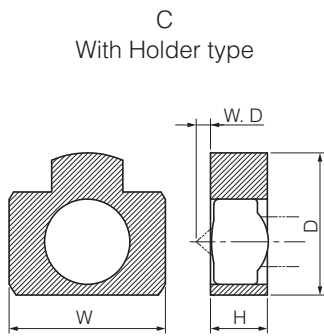

W.D : Working Distance
C.D : Coujugate Distance

Компания «Life Electronics» занимается поставками электронных компонентов импортного и отечественного производства от производителей и со складов крупных дистрибьюторов Европы, Америки и Азии.

С конца 2013 года компания активно расширяет линейку поставок компонентов по направлению коаксиальный кабель, кварцевые генераторы и конденсаторы (керамические, пленочные, электролитические), за счёт заключения дистрибьюторских договоров

Мы предлагаем:

- Конкурентоспособные цены и скидки постоянным клиентам.
- Специальные условия для постоянных клиентов.
- Подбор аналогов.
- Поставку компонентов в любых объемах, удовлетворяющих вашим потребностям.
- Приемлемые сроки поставки, возможна ускоренная поставка.
- Доставку товара в любую точку России и стран СНГ.
- Комплексную поставку.
- Работу по проектам и поставку образцов.
- Формирование склада под заказчика.
- Сертификаты соответствия на поставляемую продукцию (по желанию клиента).
- Тестирование поставляемой продукции.
- Поставку компонентов, требующих военную и космическую приемку.
- Входной контроль качества.
- Наличие сертификата ISO.

В составе нашей компании организован Конструкторский отдел, призванный помогать разработчикам, и инженерам.

Конструкторский отдел помогает осуществить:

- Регистрацию проекта у производителя компонентов.
- Техническую поддержку проекта.
- Защиту от снятия компонента с производства.
- Оценку стоимости проекта по компонентам.
- Изготовление тестовой платы монтаж и пусконаладочные работы.



Тел: +7 (812) 336 43 04 (многоканальный)

Email: org@lifeelectronics.ru