

HEDT-9000/9100

High Temperature 125°C Two Channel
Optical Incremental Encoder Modules

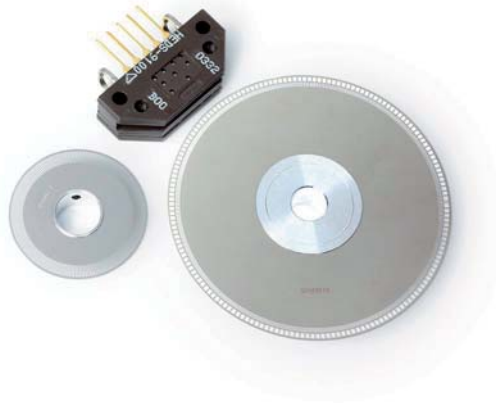

Data Sheet



Description

The HEDT-9000 and the HEDT-9100 series are high performance, low cost, optical incremental encoder modules that operate to 125°C. When used with a codewheel, these modules detect rotary position. The modules consist of a lensed (LED) source and a detector IC enclosed in a small C-shaped plastic package. Due to a highly collimated light source and unique photodetector array, these modules are extremely tolerant to mounting misalignment.

The two channel digital outputs and the single 5 V supply input are accessed through five 0.025 inch square pins located on 0.1 inch centers.

Standard resolutions for the HEDT-9000 are 500 CPR and 1000 CPR for use with a HEDS-6100 codewheel or equivalent. For the HEDT-9100, standard resolutions between 96 CPR and 512 CPR are available for use with a HEDS-5120 codewheel or equivalent.

Note: Avago Technologies encoders are not recommended for use in safety critical applications. Eg. ABS braking systems, power steering, life support systems and critical care medical equipment. Please contact sales representative if more clarification is needed.

Features

- High performance
- High resolution
- Low cost
- Easy to mount
- No signal adjustment required
- Insensitive to radial and axial play
- Small size
- -40°C to 125°C operating temperature
- Two channel quadrature output
- TTL compatible
- Single 5 V supply

Applications

The HEDT-9000 and 9100 provide sophisticated motion detection at a low cost, at temperatures to 125°C, making them ideal for high volume industrial applications.

ESD WARNING: NORMAL HANDLING PRECAUTIONS SHOULD BE TAKEN TO AVOID STATIC DISCHARGE.

Package Dimensions

HEDx-9xx0 Option

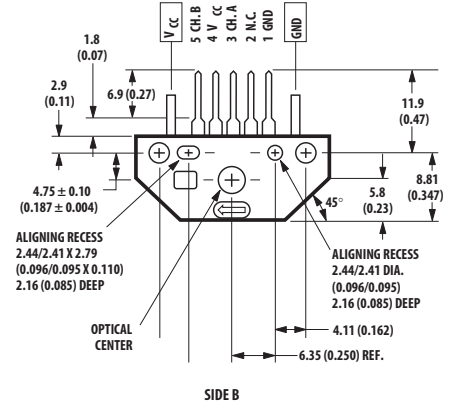
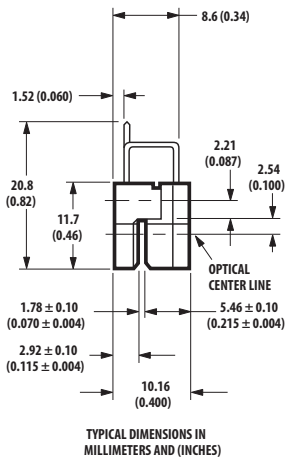
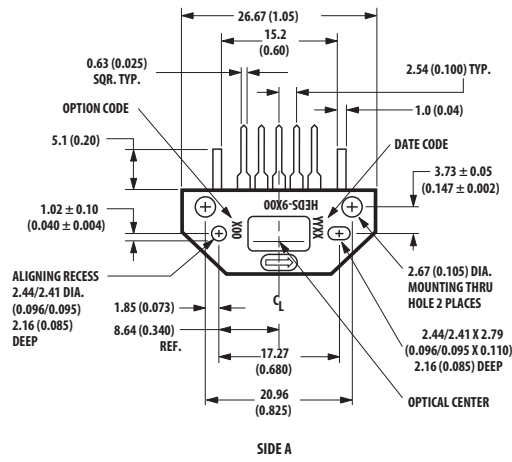

HEDx-9xx1 Option

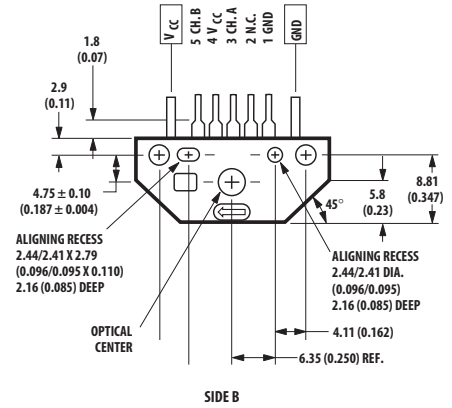
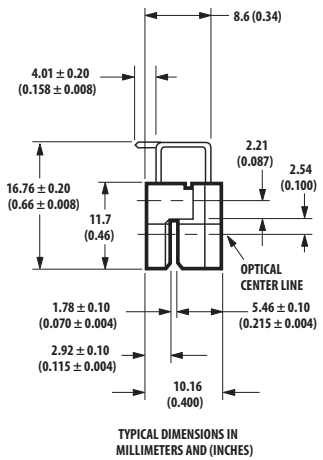
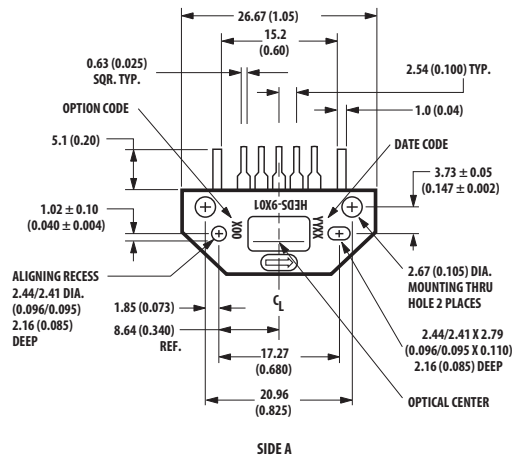

Theory of Operation

The HEDT-9000 and 9100 are C-shaped emitter/detector modules. Coupled with a codewheel, they translate the rotary motion of a shaft into a two-channel digital output.

As seen in the block diagram, each module contains a single Light Emitting Diode (LED) as its light source. The light is collimated into a parallel beam by means of a single polyetherimide lens located directly over the LED. Opposite the emitter is the integrated detector circuit. This IC consists of multiple sets of photodetectors and the signal processing circuitry necessary to product the digital waveforms.

Block Diagram

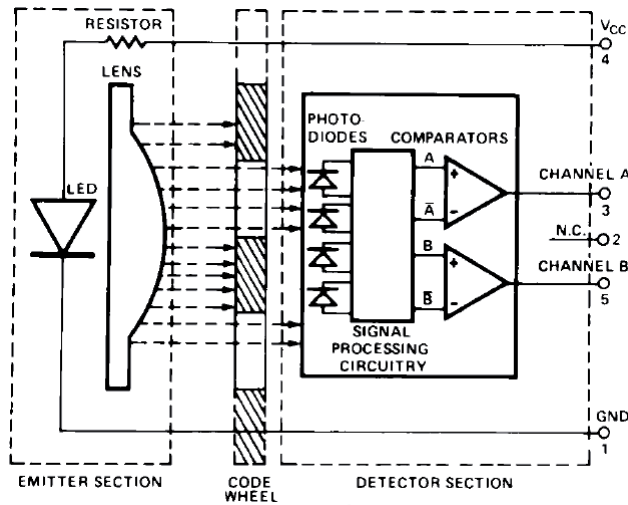

The codewheel rotates between the emitter and detector, causing the light beam to be interrupted by the pattern of spaces and bars on the codewheel. The photodiodes which detect these interruptions are arranged in a pattern that corresponds to the radius and design of the codewheel. These detectors are also spaced such that a light period on one pair of detectors corresponds to a dark period on the adjacent pair of detectors. The photodiode outputs are then fed through the signal processing circuitry resulting in A, \bar{A} , B, and \bar{B} . Two comparators receive these signals and produce the final outputs for channels A and B. Due to this integrated phasing technique, the digital output of channel A is in quadrature with that of channel B (90 degrees out of phase).

Definitions

Count (N): The number of bar and window pairs or counts per revolution (CPR) of the codewheel.

$$1 \text{ Shaft Rotation} = 360 \text{ mechanical degrees,} \\ = N \text{ cycles.}$$

$$1 \text{ cycle (C)} = 360 \text{ electrical degrees (}^\circ\text{e),} \\ = 1 \text{ bar and window pair.}$$

Pulse Width (P): The number of electrical degrees that an output is high during 1 cycle. This value is nominally 180°e or 1/2 cycle.

Pulse Width Error (ΔP): The deviation, in electrical degrees of the pulse width from its ideal value of 180°e.

State Width (S): The number of electrical degrees between a transition in the output of channel A and the neighboring transition in the output of channel B. There are 4 states per cycle, each nominally 90°e.

State Width Error (ΔS): The deviation, in electrical degrees, of each state width from its ideal value of 90°e.

Phase (ϕ): The number of electrical degrees between the center of the high state of channel A and the center of the high state of channel B. This value is nominally 90°e for quadrature output.

Phase Error ($\Delta\phi$): The deviation of the phase from its ideal value of 90°e.

Direction of Rotation: When the codewheel rotates in the direction of the arrow on top of the module, channel A will lead channel B. If the codewheel rotates in the opposite direction, channel B will lead channel A.

Optical Radius (R_{op}): The distance from the codewheel's center of rotation to the optical center (O.C.) of the encoder module.

Output Waveforms

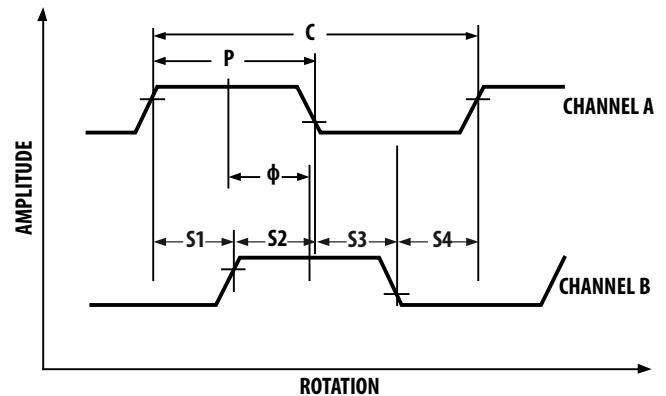

Absolute Maximum Ratings

Storage Temperature, T_s	-40°C to 125°C
Operating Temperature, T_A	-40°C to 125°C
Supply Voltage, V_{CC}	-0.5 V to 7 V
Output Voltage, V_O	-0.5 V to V_{CC}
Output Current per Channel, I_{out}	-1.0 mA to 5 mA

Recommended Operating Conditions

Parameter	Symbol	Min.	Typ.	Max.	Units	Notes
Temperature	T	-40		125	°C	
Supply Voltage	V_{CC}	4.5		5.5	Volts	Ripple < 100 mV _{p-p}
Load Capacitance	C_L			100	pF	3.3 kΩ pull-up resistor
Count Frequency	f			100	kHz	$\frac{\text{Velocity (rpm)} \times N}{60}$

Note: The module performance is guaranteed to 100 kHz but can operate at higher frequencies.

Encoding Characteristics

Encoding Characteristics over Recommended Operating Range and Recommended Mounting Tolerances. These Characteristics do not include codewheel/codestrip contributions.

Description	Sym.	Typ.	Case 1 Max.	Case 2 Max.	Units	Notes
Pulse Width Error	ΔP	7	35	45	°e	
Logic State Width Error	ΔS	5	35	45	°e	
Phase Error	$\Delta \phi$	2	15	20	°e	

Case 1: Module mounted on tolerance circle of ± 0.13 mm (± 0.005 in.).

Case 2: HEDT-9000 mounted on tolerances of ± 0.50 mm (0.020").
HEDT-9100 mounted on tolerances of ± 0.38 mm (0.015").

Electrical Characteristics

Electrical Characteristics over Recommended Operating Range, typical at 25°C.

Parameter	Symbol	Min.	Typical	Max.	Units	Notes
Supply Current	I_{CC}		17	40	mA	
High Level Output Voltage	V_{OH}	2.4			Volts	$I_{OH} = -40 \mu A$ max.
Low Level Output Voltage	V_{OL}			0.4	Volts	$I_{OL} = 3.2$ mA
Rise Time	t_r		200		ns	$C_L = 25$ pF
Fall Time	t_f		50		ns	$R_L = 11$ kΩ pull-up

Recommended Codewheel Characteristics

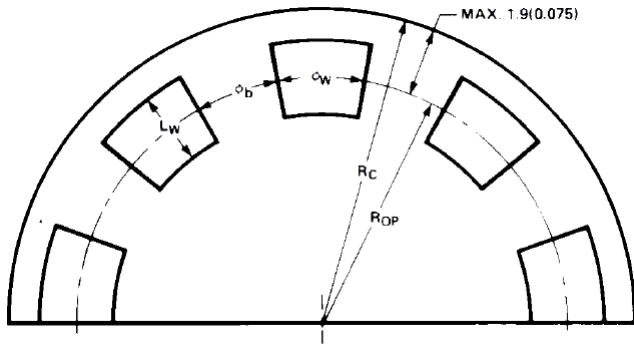

Figure 1. Codestrip Design.

Codewheel Options

HEDS Series	CPR (N)	Option	Optical Radius mm (in.)
5120	96	K	11.00 (0.433)
5120	100	C	11.00 (0.433)
5120	192	D	11.00 (0.433)
5120	200	E	11.00 (0.433)
5120	256	F	11.00 (0.433)
5120	360	G	11.00 (0.433)
5120	400	H	11.00 (0.433)
5120	500	A	11.00 (0.433)
5120	512	I	11.00 (0.433)
6100	500	A	23.36 (0.920)
6100	1000	B	23.36 (0.920)

Parameter	Symbol	Minimum	Maximum	Units	Notes
Window/Bar Ratio	ϕ_w/ϕ_b	0.7	1.4		
Window Length	L	1.8 (0.07)	2.3 (0.09)	mm (inch)	
Absolute Maximum Codewheel Radius	R_c		$R_{op} + 1.9 (0.075)$	mm (inch)	Includes eccentricity errors

Mounting Considerations

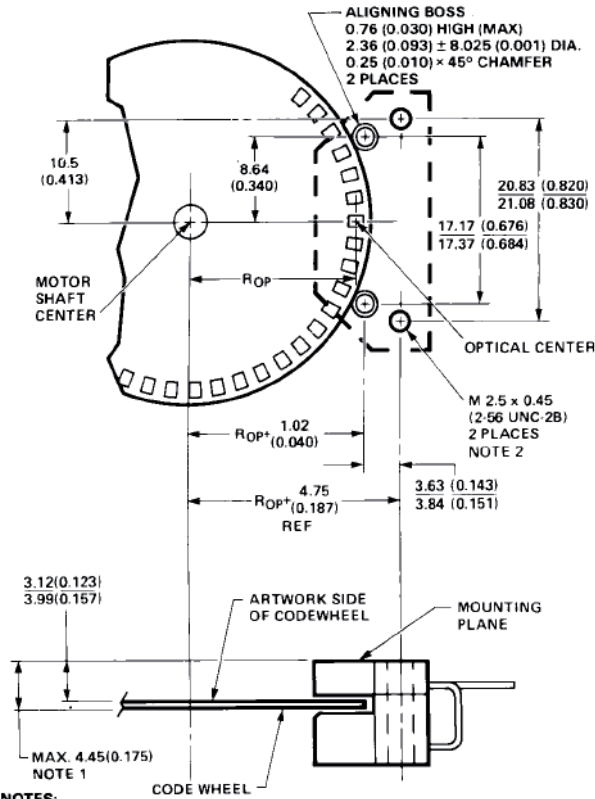

Figure 2. Mounting Plane Side A.

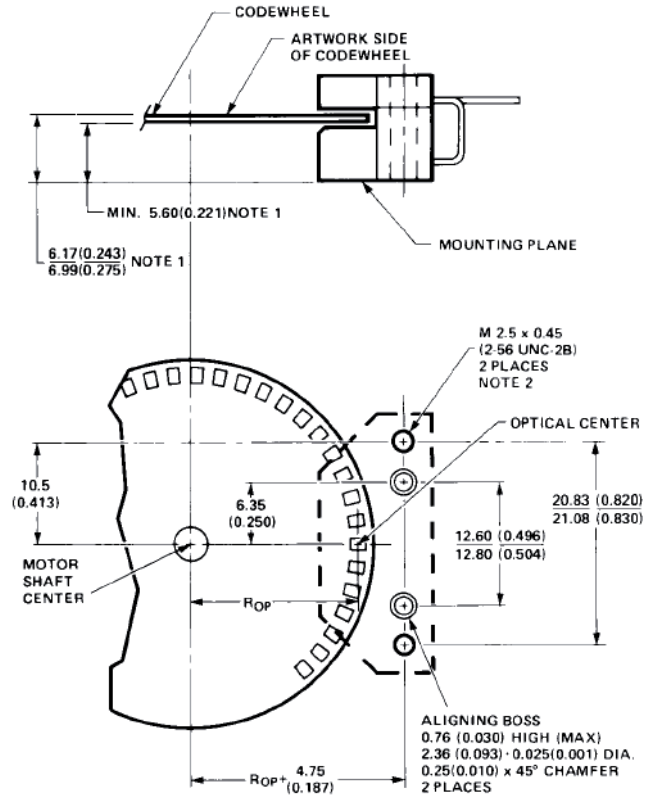

Figure 3. Mounting Plane Side B.

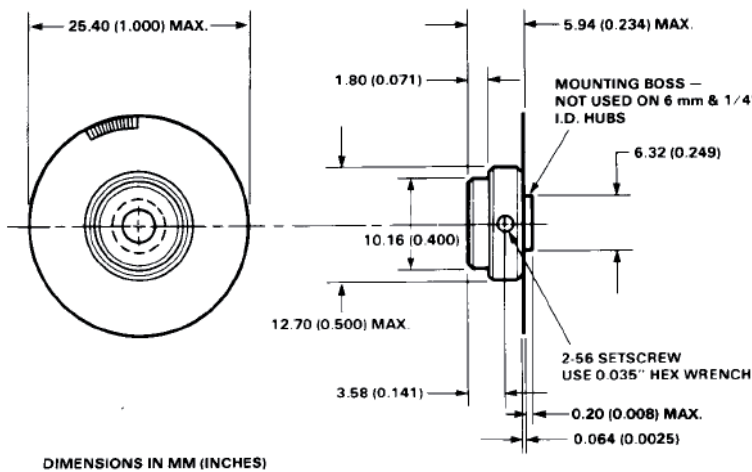

Figure 4. HEDS-5120 Codewheel.

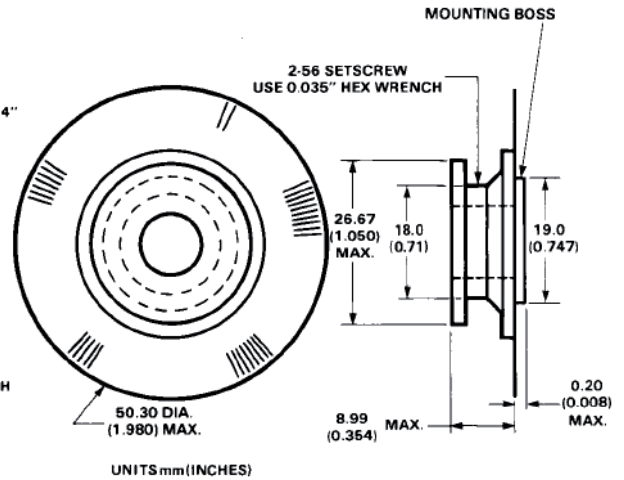

Figure 5. HEDS-6100 Codewheel.

Ordering Information

HEDT-9001 Option

0 0

HEDS-6100 Option

Resolution (Cycles/Rev)
A - 500

Shaft Diameter	
06 - 1/4 in.	09 - 1/2 in.
08 - 3/8 in.	10 - 5/8 in.

HEDT-910

Option

0 0

HEDS-5120 Option

Lead
0 - Straight Leads
1 - Bent Leads

Resolution (Cycles/Rev)	
C - 100 CPR	G - 360 CPR
D - 192 CPR	A - 500 CPR
E - 200 CPR	I - 512 CPR

Shaft Diameter	
01 - 2 mm	11 - 4 mm
02 - 3 mm	14 - 5 mm
03 - 1/8 in.	12 - 6 mm
04 - 5/32 in.	13 - 8 mm
05 - 3/16 in.	
06 - 1/4 in.	

	A	C	D	E	G	I
HEDT-9001	*					
HEDT-9100	*	*		*	*	*
HEDT-9101	*	*	*	*	*	*

		01	02	03	04	05	06	08	09	10	11	12	13	14
HEDS-6100	A								*			*	*	

		01	02	03	04	05	06	08	09	10	11	12	13	14
HEDS-5120	A	*	*	*	*	*	*				*	*		*
	C		*				*				*	*	*	*
	D					*								
	E						*					*		
	F					*								
	G		*	*		*	*				*			*
	H		*				*				*	*		*
	I		*											
	K		*										*	

For product information and a complete list of distributors, please go to our website: www.avagotech.com

Avago, Avago Technologies, and the A logo are trademarks of Avago Technologies in the United States and other countries.
Data subject to change. Copyright © 2005-2011 Avago Technologies. All rights reserved. Obsoletes 5988-5280EN
AV02-1055EN - January 12, 2011

Avago
TECHNOLOGIES

Компания «Life Electronics» занимается поставками электронных компонентов импортного и отечественного производства от производителей и со складов крупных дистрибьюторов Европы, Америки и Азии.

С конца 2013 года компания активно расширяет линейку поставок компонентов по направлению коаксиальный кабель, кварцевые генераторы и конденсаторы (керамические, пленочные, электролитические), за счёт заключения дистрибьюторских договоров

Мы предлагаем:

- Конкуренспособные цены и скидки постоянным клиентам.
- Специальные условия для постоянных клиентов.
- Подбор аналогов.
- Поставку компонентов в любых объемах, удовлетворяющих вашим потребностям.
- Приемлемые сроки поставки, возможна ускоренная поставка.
- Доставку товара в любую точку России и стран СНГ.
- Комплексную поставку.
- Работу по проектам и поставку образцов.
- Формирование склада под заказчика.
- Сертификаты соответствия на поставляемую продукцию (по желанию клиента).
- Тестирование поставляемой продукции.
- Поставку компонентов, требующих военную и космическую приемку.
- Входной контроль качества.
- Наличие сертификата ISO.

В составе нашей компании организован Конструкторский отдел, призванный помогать разработчикам, и инженерам.

Конструкторский отдел помогает осуществить:

- Регистрацию проекта у производителя компонентов.
- Техническую поддержку проекта.
- Защиту от снятия компонента с производства.
- Оценку стоимости проекта по компонентам.
- Изготовление тестовой платы монтаж и пусконаладочные работы.



Тел: +7 (812) 336 43 04 (многоканальный)
Email: org@lifeelectronics.ru