

Power Management IC Series for Automotive Body Control



Motor Driver

BD6941FM

No.09039EAT02

●Description

BD6941FM is the reversible motor driver for output 1.25A (1Motor), and can control a DC motor in four modes (Forward, Reverse, Standby, Brake) corresponding to two control logic inputs.

●Features

- 1) 1 ch DMOS H bridge output
- 2) Four output states (Forward,Reverse,Standby,Brake) by two control logic
- 3) Built-in surge-absorbing diodes
- 4) Low standby current
- 5) Output overcurrent protection with timer.
- 6) Over voltage detection switch off
- 7) TSD detects junction temperature and circuitry switches off the outputs at high temperature.
- 8) Built-in protection monitor pin (PO)

●Applications

Onboard devices(Vehicle equipment etc)

●Absolute Maximum Ratings (Ta=25°C)

PARAMETER	SYMBOL	LIMIT	UNIT
SUPPLY VOLTAGE	Vcc	50	V
INPUT VOLTAGE	V _{INP} , V _{INN}	-0.3~20	V
OUTPUT CURRENT	I _o	1.25 (* 1)	A
POWER DISSIPATION	Pd	2.8 (* 2)	W
OPERATING TEMPERATURE	Topr	-40~105	°C
STORAGE TEMPERATURE	Tstg	-55~150	°C
JUNCTION TEMPERATURE	Tjmax	150	°C

*1 Not to exceed Pd and ASO.

*2 Mounted on a glass epoxy PCB (70mm × 70mm × 1.6mm).

To use at temperature above Ta=25°C reduce 22.4mW/°C.

●Operating Range

PARAMETER	SYMBOL	LIMIT	UNIT
SUPPLY VOLTAGE	Vcc	8.0~16.0	V

●Electrical Characteristics (Unless otherwise specified, $V_{CC}=8V\sim 16V$, $T_a=-40^{\circ}C\sim 105^{\circ}C$)

PARAMETER	SYMBOL	LIMIT			UNIT	CONDITIONS
		MIN.	TYP.	MAX		
Circuit current 1	I_{CC1}	-	0	10	μA	Standby mode
Circuit current 2	I_{CC2}	-	3	8	mA	Forward or reverse mode
Circuit current 3	I_{CC3}	-	3	8	mA	Brake mode
Input Voltage "H" level	V_{IH}	3.0	-	-	V	
Input Voltage "L" level	V_{IL}	-	-	1.0	V	
"H" level input current	I_{IH}	-	50	100	μA	$V_{IN}=5.0V$, flowing in current
"L" level input current	I_{IL}	-	0	10	μA	$V_{IN}=0V$, flowing out current
Output on voltage 1	V_{ON1}	-	0.84	1.5	V	$V_{CC}=12V$, $I_{out}=0.5A$, total drop
Output on voltage 2	V_{ON2}	-	-	1.7	V	$V_{CC}=8\sim 16V$, $I_{out}=0.5A$, total drop
Output leakage current "H"	I_{LH}	-	0	10	μA	$V_{OUT}=0V$
Output leakage current "L"	I_{LL}	-	0	10	μA	$V_{OUT}=V_{CC}$
Upper free-wheeling diode forward voltage	V_{FH}	0.3	1.0	1.5	V	$I_F=0.6A$
Lower free-wheeling diode forward voltage	V_{FL}	0.3	1.0	1.5	V	$I_F=0.6A$
Protection monitor voltage	V_{LPO}	-	-	0.6	V	$I_{PO}=3mA$
Protection monitor leakage current	I_{LPO}	-	0	10	μA	$V_{PO}=V_{CC}$
Over current protection switch on current	I_{OCP}	1.5	-	3.5	A	
Over Voltage Lockout lockout switch on voltage	V_{OVP}	25	30	35	V	

●Heat Reduction Curve

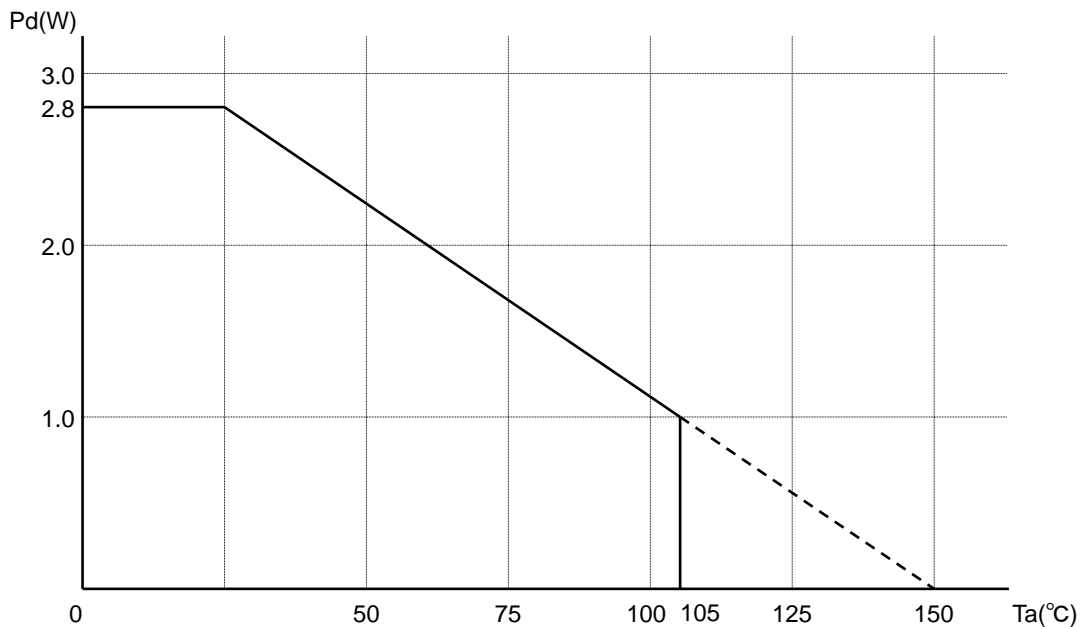

Mounted on a glass epoxy PCB (70mm × 70mm × 1.6mm)

To use at temperature above $T_a=25^{\circ}C$ reduce 22.4mW/°C.

●Reference Data

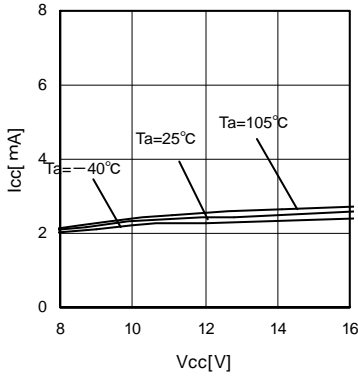

Fig.1 Circuit current (Forward · Reverse · Brake)

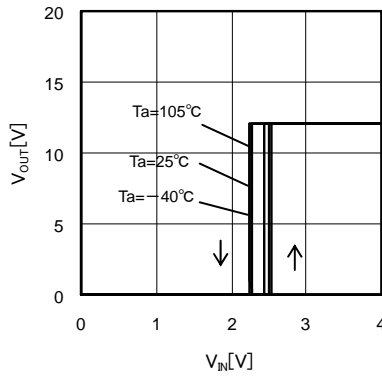

Fig.2 Input voltage vs. Output voltage

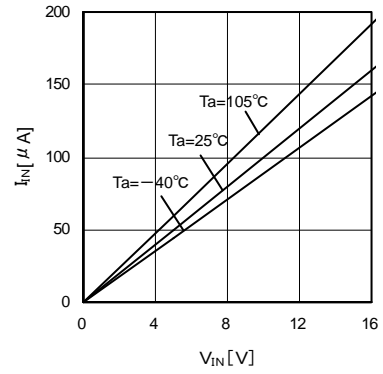

Fig.3 Input H current

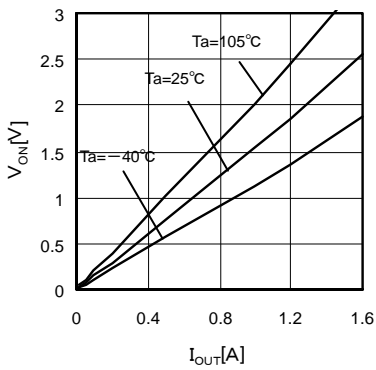

Fig.4 Output on voltage ($V_{cc}=12\text{V}$)

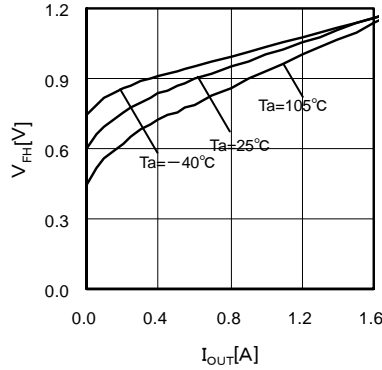

Fig.5 Upper free-wheeling diode forward voltage H

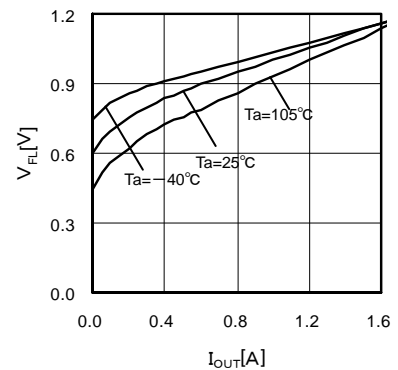

Fig.6 Upper free-wheeling diode forward voltage L

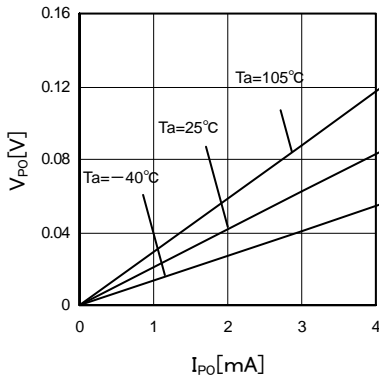

Fig.7 Protection monitor voltage

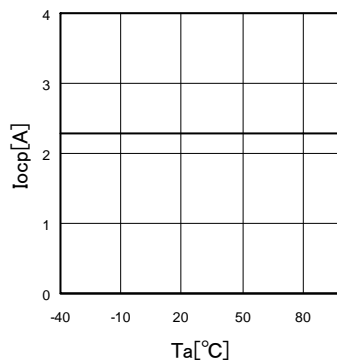

Fig.8 Over current protection switch on current

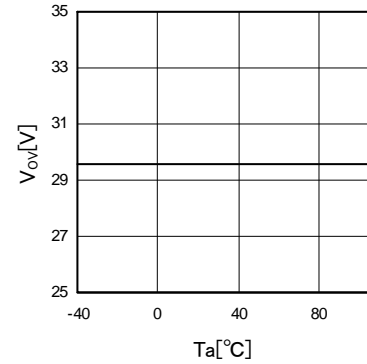

Fig.9 Over Voltage Lockout lockout switch on voltage

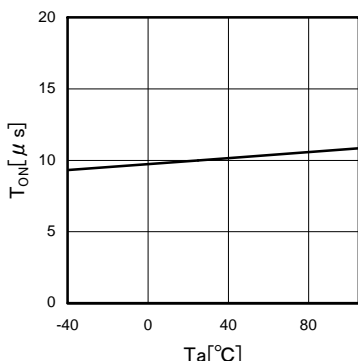

Fig.10 Over current protection monitor on time

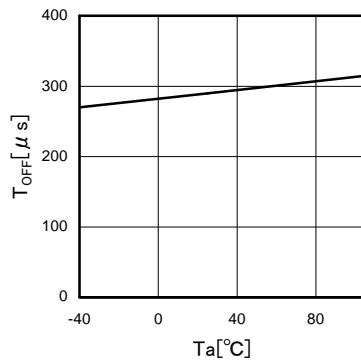

Fig.11 Over current protection monitor off time

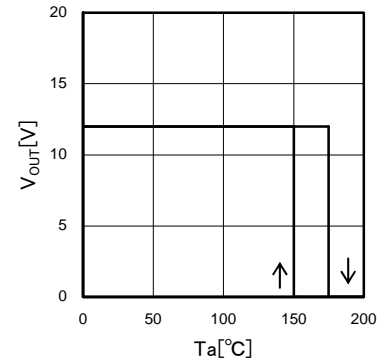
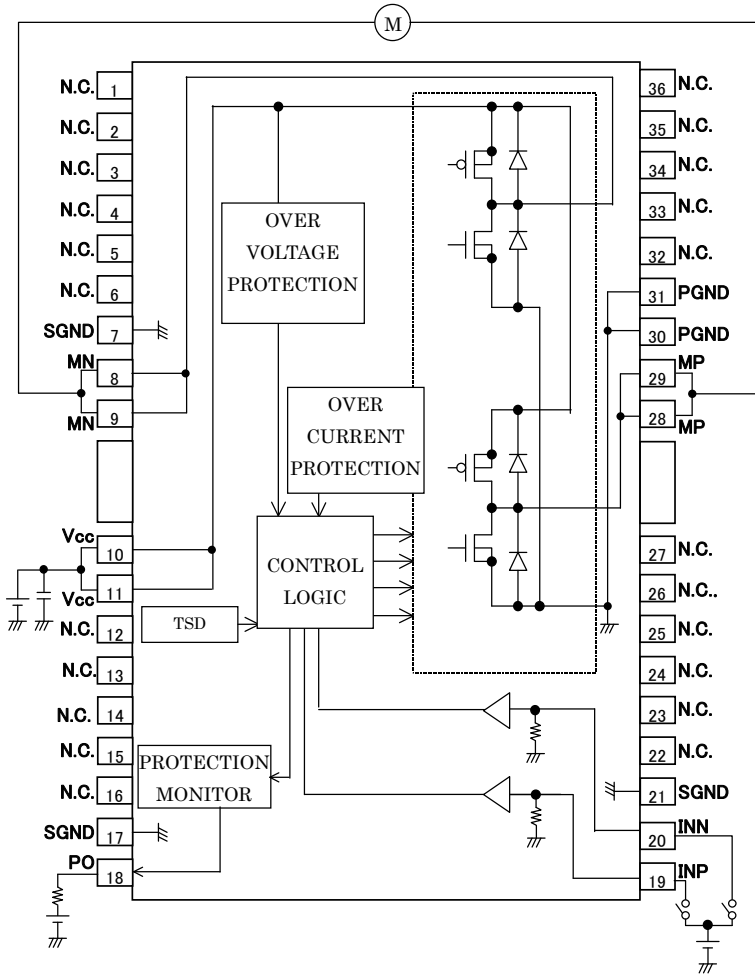

Fig.12 TSD temperature

●Block Diagram



●Terminal Function Table

PIN No.	Terminal Name	Function
1-6	N.C.	N.C.
7	SGND	Signal GND Pin
8	MN	Motor Output Pin
9	MN	Motor Output Pin
FIN	FIN	FIN
10	Vcc	Power Supply Pin
11	Vcc	Power Supply Pin
12-16	N.C.	N.C.
17	SGND	Signal GND Pin
18	PO	Protection Monitor Pin(Open drain)
19	INP	Logic Input Pin
20	INN	Logic Input Pin
21	SGND	Signal GND Pin
22-27	N.C.	N.C.
FIN	FIN	FIN
28	MP	Motor Output Pin
29	MP	Motor Output Pin
30	PGND	Power GND Pin
31	PGND	Power GND Pin
32-36	N.C.	N.C.

●Package

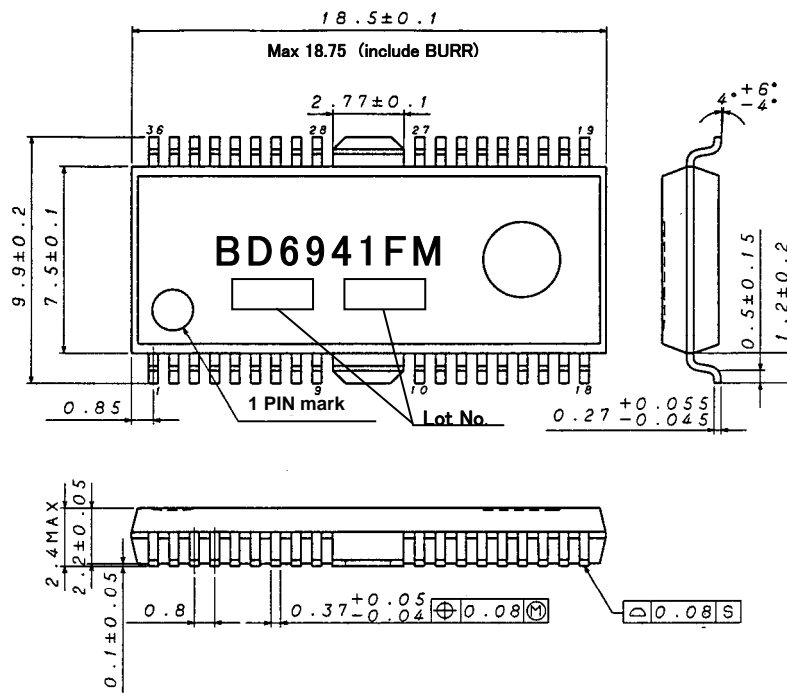

HSOP-M36(Unit : mm)

●Signal Table

Input/Output Truth Table

IN		OUT		MODE
INP	INN	MP	MN	
H	H	L	L	BRAKE
H	L	H	L	FORWARD
L	H	L	H	REVERSE
L	L	Open	Open	STANDBY

Output Condition

IN		OUT		PO
INP	INN	MODE	LOAD	
H	H	BRAKE	NORMAL	H
			SHORT	L * 2
H/L	L/H	FORWARD/ REVERSE	NORMAL	H
			SHORT	L * 2
L	L	STANDBY	-	H

* 2 refer to timing chart

●PO Output Timing Chart

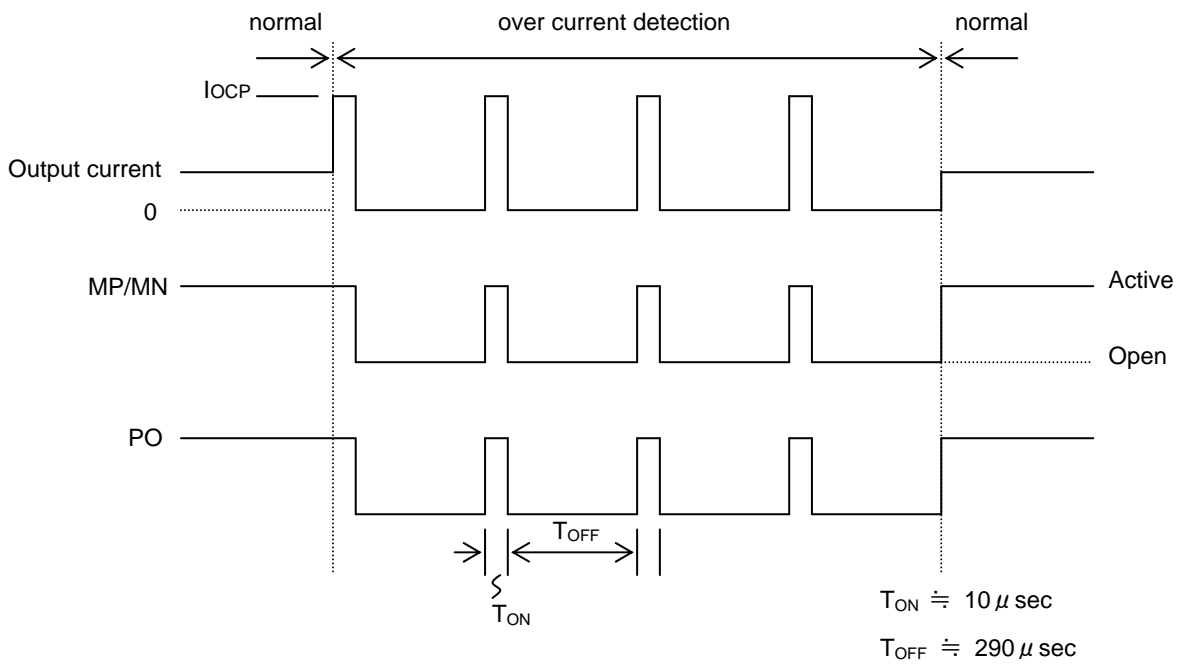

● I/O Circuit Diagram

1) INP, INN

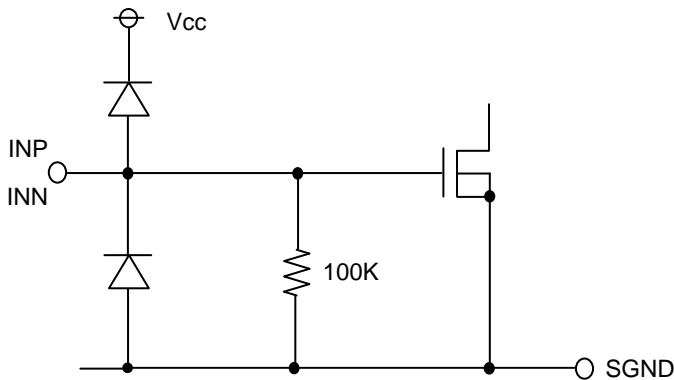

2) PO

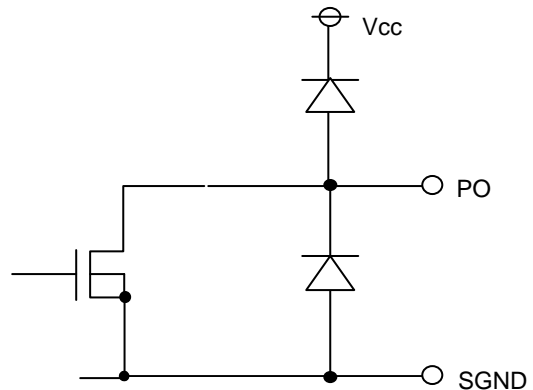

3) MP, MN

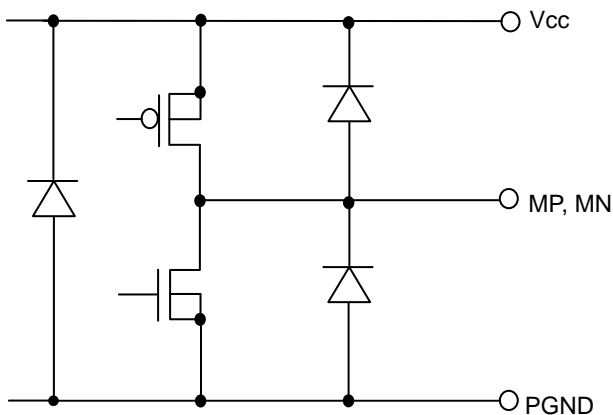

● Operating Notes

1) Absolute maximum ratings

Use of the IC in excess of absolute maximum ratings such as the applied voltage or operating temperature range may result in IC damage. Assumptions should not be made regarding the state of the IC (short mode or open mode) when such damage is suffered. A physical safety measure such as a fuse should be implemented when use of the IC in a special mode where the absolute maximum ratings may be exceeded is anticipated.

2) GND potential

Ensure a minimum GND pin potential in all operating conditions.

3) Thermal design

Use a thermal design that allows for a sufficient margin in light of the power dissipation (Pd) in actual operating conditions.

4) Pin short and mistake mounting

Use caution when orienting and positioning the IC for mounting on printed circuit boards. Improper mounting may result in damage to the IC. Shorts between output pins and the power supply and GND pins caused by the presence of a foreign object may result in damage to the IC. Ensure a minimum GND pin potential in all operating conditions.

5) Actions in strong magnetic field

Keep in mind that the IC may malfunction in strong magnetic fields.

6) Testing on application boards

When testing the IC on an application board, connecting a capacitor to a pin with low impedance subjects the IC to stress. Always discharge capacitors after each process or step. Always turn the IC's power supply off before connecting it to or removing it from a jig or fixture during the inspection process. Ground the IC during assembly steps as an antistatic measure, and use similar caution when transporting or storing the IC.

7) IC terminal input voltage

This monolithic IC contains P+ isolation and P substrate layers between adjacent elements in order to keep them isolated. P/N junctions are formed at the intersection of these P layers with the N layers of other elements to create a variety of parasitic elements. For example, when the resistors and transistors are connected to the pins as shown in the following figure,

- The P/N junction functions as a parasitic diode when $GND > Pin A$ for the resistor or $GND > Pin B$ for the transistor (NPN).
- Similarly, when $GND > Pin B$ for the transistor (NPN), the parasitic diode described above combines with the N layer of other adjacent elements to operate as a parasitic NPN transistor.

The formation of parasitic elements as a result of the relationships of the potentials of different pins is an inevitable result of the IC's architecture. The operation of parasitic elements can cause interference with circuit operation as well as IC malfunction and damage. For these reasons, it is necessary to use caution so that the IC is not used in a way that will trigger the operation of parasitic elements, such as by the application of voltages lower than the GND (P substrate) voltage to input pins.

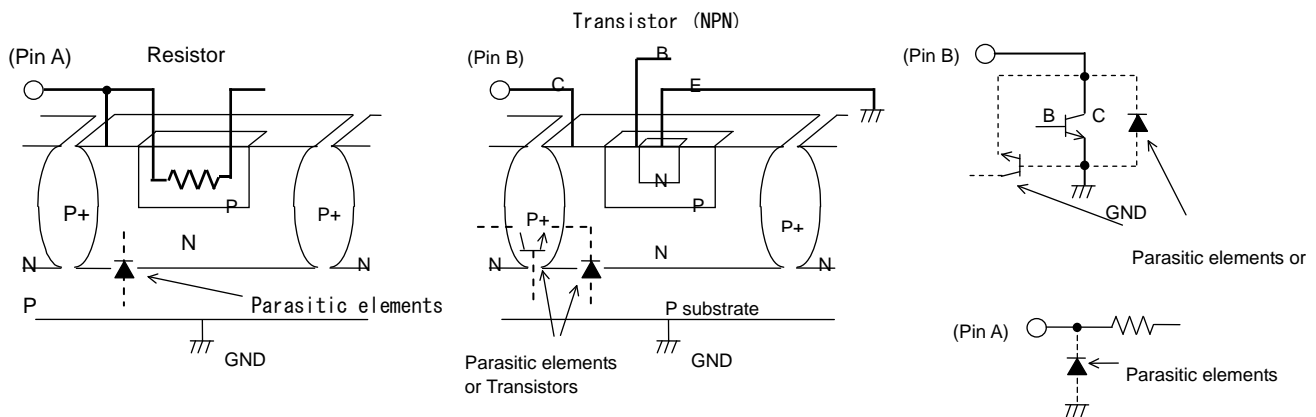

8) Input terminals

Do not apply the voltage to input pin when the Vcc is not applied. And when the Vcc is applied, the voltage of input pin must not exceed Vcc. It is feared that output get malfunction, as input voltage is swept slowly near the H, L threshold voltage. Please pay attention to input slew rate.

9) Back electro motive force (BEMF)

There is a possibility that the BEMF is changed by use of the operating condition, environment and the individual characteristics of motor. Please make sure there is no problem of operating the IC although the BEMF is occurred.

10) The note of pattern design at printed circuit

This IC flows large current between power supply for motor division and GND. So, it is feared that get undesirable result malfunction, oscillation and so on, as input lines is affected by large output current. Please consider pattern design at printed circuit doesn't have common impedance on output large current lines-input lines. Please consider to keep low impedance of power supply for fear of oscillation from power supply high impedance, also.

11) Rash current

This IC doesn't have current limit circuit for rash current. Therefore physical security countermeasure, like current limit resistor is to be given.

12) Thermal shutdown circuit

This IC incorporates a built-in TSD circuit for the protection from thermal destruction. The IC should be used within the specified power dissipation range. However, in the event that the IC continues to be operated in excess of its power dissipation limits, the attendant rise in the junction temperature (Tj) will trigger the TSD circuit to turn off all output power elements. The circuit automatically resets once the junction temperature (Tj) drops. Operation of the TSD circuit presumes that the IC's absolute maximum ratings have been exceeded. Application designs should never make use of the TSD circuit.

13) Over voltage lock out function

This IC has the function of turning off the output when detecting the over voltage. More than 30V(typ.) triggers this function. But in the standby mode, this function does not work. Although this IC has over voltage lockout function, the voltage that exceeds absolute maximum ratings might destroy the IC. Please do not exceed the absolute maximum ratings.

14) Over current protection

This IC has the function of turning off the output when detecting the over current. More than 2.25A(typ.) triggers this function. When detecting the over current for 10 μ sec(typ.), this function turns off the output(output terminals become Hi-impedance) for 290 μ sec(typ.). After the period of turning off time (290 μ sec) , the output current recovers. But if the over current is still detected, this function will work again.This function is for protecting IC because of the output short etc. but the continuing detection of over current might cause the extreme heat and damage the IC. It is recommended to change the IC's state to standby mode by the application. And please pay attention to the power dissipation.

●Ordering part number

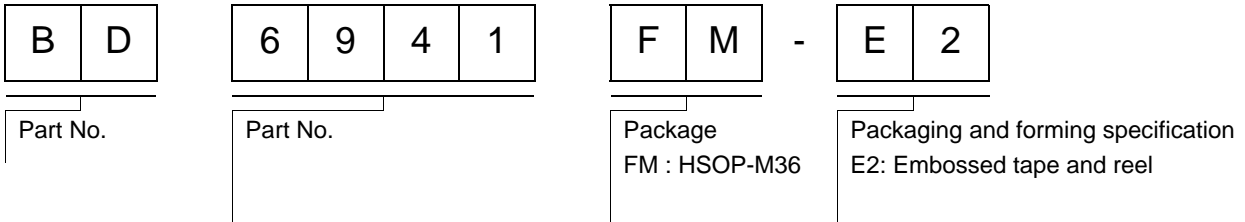

HSOP-M36

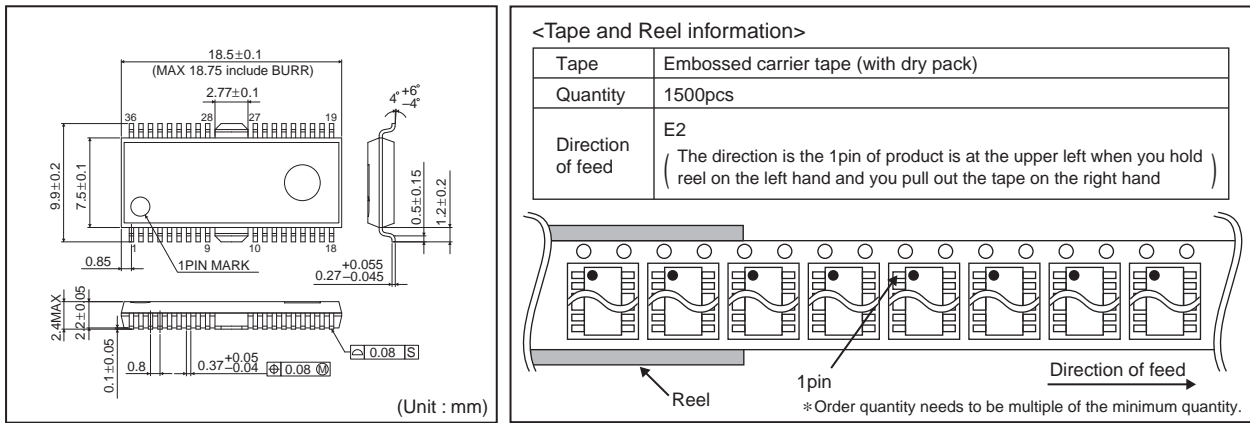

<Tape and Reel information>

Tape	Embossed carrier tape (with dry pack)
Quantity	1500pcs
Direction of feed	E2 (The direction is the 1pin of product is at the upper left when you hold reel on the left hand and you pull out the tape on the right hand)

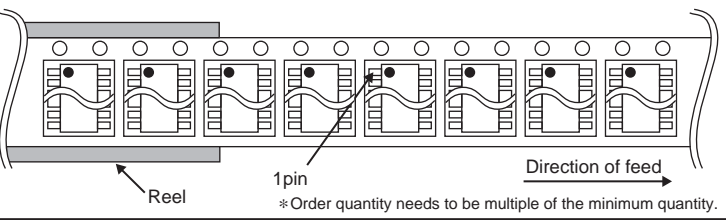

Notice

Precaution on using ROHM Products

- Our Products are designed and manufactured for application in ordinary electronic equipments (such as AV equipment, OA equipment, telecommunication equipment, home electronic appliances, amusement equipment, etc.). If you intend to use our Products in devices requiring extremely high reliability (such as medical equipment ^(Note 1), transport equipment, traffic equipment, aircraft/spacecraft, nuclear power controllers, fuel controllers, car equipment including car accessories, safety devices, etc.) and whose malfunction or failure may cause loss of human life, bodily injury or serious damage to property ("Specific Applications"), please consult with the ROHM sales representative in advance. Unless otherwise agreed in writing by ROHM in advance, ROHM shall not be in any way responsible or liable for any damages, expenses or losses incurred by you or third parties arising from the use of any ROHM's Products for Specific Applications.

(Note1) Medical Equipment Classification of the Specific Applications

JAPAN	USA	EU	CHINA
CLASS III	CLASS III	CLASS II b	CLASS III
CLASS IV		CLASS III	

- ROHM designs and manufactures its Products subject to strict quality control system. However, semiconductor products can fail or malfunction at a certain rate. Please be sure to implement, at your own responsibilities, adequate safety measures including but not limited to fail-safe design against the physical injury, damage to any property, which a failure or malfunction of our Products may cause. The following are examples of safety measures:
 - Installation of protection circuits or other protective devices to improve system safety
 - Installation of redundant circuits to reduce the impact of single or multiple circuit failure
- Our Products are designed and manufactured for use under standard conditions and not under any special or extraordinary environments or conditions, as exemplified below. Accordingly, ROHM shall not be in any way responsible or liable for any damages, expenses or losses arising from the use of any ROHM's Products under any special or extraordinary environments or conditions. If you intend to use our Products under any special or extraordinary environments or conditions (as exemplified below), your independent verification and confirmation of product performance, reliability, etc. prior to use, must be necessary:
 - Use of our Products in any types of liquid, including water, oils, chemicals, and organic solvents
 - Use of our Products outdoors or in places where the Products are exposed to direct sunlight or dust
 - Use of our Products in places where the Products are exposed to sea wind or corrosive gases, including Cl₂, H₂S, NH₃, SO₂, and NO₂
 - Use of our Products in places where the Products are exposed to static electricity or electromagnetic waves
 - Use of our Products in proximity to heat-producing components, plastic cords, or other flammable items
 - Sealing or coating our Products with resin or other coating materials
 - Use of our Products without cleaning residue of flux (even if you use no-clean type fluxes, cleaning residue of flux is recommended); or Washing our Products by using water or water-soluble cleaning agents for cleaning residue after soldering
 - Use of the Products in places subject to dew condensation
- The Products are not subject to radiation-proof design.
- Please verify and confirm characteristics of the final or mounted products in using the Products.
- In particular, if a transient load (a large amount of load applied in a short period of time, such as pulse. is applied, confirmation of performance characteristics after on-board mounting is strongly recommended. Avoid applying power exceeding normal rated power; exceeding the power rating under steady-state loading condition may negatively affect product performance and reliability.
- De-rate Power Dissipation (Pd) depending on Ambient temperature (Ta). When used in sealed area, confirm the actual ambient temperature.
- Confirm that operation temperature is within the specified range described in the product specification.
- ROHM shall not be in any way responsible or liable for failure induced under deviant condition from what is defined in this document.

Precaution for Mounting / Circuit board design

- When a highly active halogenous (chlorine, bromine, etc.) flux is used, the residue of flux may negatively affect product performance and reliability.
- In principle, the reflow soldering method must be used; if flow soldering method is preferred, please consult with the ROHM representative in advance.

For details, please refer to ROHM Mounting specification

Precautions Regarding Application Examples and External Circuits

1. If change is made to the constant of an external circuit, please allow a sufficient margin considering variations of the characteristics of the Products and external components, including transient characteristics, as well as static characteristics.
2. You agree that application notes, reference designs, and associated data and information contained in this document are presented only as guidance for Products use. Therefore, in case you use such information, you are solely responsible for it and you must exercise your own independent verification and judgment in the use of such information contained in this document. ROHM shall not be in any way responsible or liable for any damages, expenses or losses incurred by you or third parties arising from the use of such information.

Precaution for Electrostatic

This Product is electrostatic sensitive product, which may be damaged due to electrostatic discharge. Please take proper caution in your manufacturing process and storage so that voltage exceeding the Products maximum rating will not be applied to Products. Please take special care under dry condition (e.g. Grounding of human body / equipment / solder iron, isolation from charged objects, setting of Ionizer, friction prevention and temperature / humidity control).

Precaution for Storage / Transportation

1. Product performance and soldered connections may deteriorate if the Products are stored in the places where:
 - [a] the Products are exposed to sea winds or corrosive gases, including Cl₂, H₂S, NH₃, SO₂, and NO₂
 - [b] the temperature or humidity exceeds those recommended by ROHM
 - [c] the Products are exposed to direct sunshine or condensation
 - [d] the Products are exposed to high Electrostatic
2. Even under ROHM recommended storage condition, solderability of products out of recommended storage time period may be degraded. It is strongly recommended to confirm solderability before using Products of which storage time is exceeding the recommended storage time period.
3. Store / transport cartons in the correct direction, which is indicated on a carton with a symbol. Otherwise bent leads may occur due to excessive stress applied when dropping of a carton.
4. Use Products within the specified time after opening a humidity barrier bag. Baking is required before using Products of which storage time is exceeding the recommended storage time period.

Precaution for Product Label

QR code printed on ROHM Products label is for ROHM's internal use only.

Precaution for Disposition

When disposing Products please dispose them properly using an authorized industry waste company.

Precaution for Foreign Exchange and Foreign Trade act

Since our Products might fall under controlled goods prescribed by the applicable foreign exchange and foreign trade act, please consult with ROHM representative in case of export.

Precaution Regarding Intellectual Property Rights

1. All information and data including but not limited to application example contained in this document is for reference only. ROHM does not warrant that foregoing information or data will not infringe any intellectual property rights or any other rights of any third party regarding such information or data. ROHM shall not be in any way responsible or liable for infringement of any intellectual property rights or other damages arising from use of such information or data.:
2. No license, expressly or implied, is granted hereby under any intellectual property rights or other rights of ROHM or any third parties with respect to the information contained in this document.

Other Precaution

1. This document may not be reprinted or reproduced, in whole or in part, without prior written consent of ROHM.
2. The Products may not be disassembled, converted, modified, reproduced or otherwise changed without prior written consent of ROHM.
3. In no event shall you use in any way whatsoever the Products and the related technical information contained in the Products or this document for any military purposes, including but not limited to, the development of mass-destruction weapons.
4. The proper names of companies or products described in this document are trademarks or registered trademarks of ROHM, its affiliated companies or third parties.

General Precaution

1. Before you use our Products, you are requested to carefully read this document and fully understand its contents. ROHM shall not be in any way responsible or liable for failure, malfunction or accident arising from the use of any ROHM's Products against warning, caution or note contained in this document.
2. All information contained in this document is current as of the issuing date and subject to change without any prior notice. Before purchasing or using ROHM's Products, please confirm the latest information with a ROHM sales representative.
3. The information contained in this document is provided on an "as is" basis and ROHM does not warrant that all information contained in this document is accurate and/or error-free. ROHM shall not be in any way responsible or liable for any damages, expenses or losses incurred by you or third parties resulting from inaccuracy or errors of or concerning such information.

Компания «Life Electronics» занимается поставками электронных компонентов импортного и отечественного производства от производителей и со складов крупных дистрибьюторов Европы, Америки и Азии.

С конца 2013 года компания активно расширяет линейку поставок компонентов по направлению коаксиальный кабель, кварцевые генераторы и конденсаторы (керамические, пленочные, электролитические), за счёт заключения дистрибьюторских договоров

Мы предлагаем:

- Конкурентоспособные цены и скидки постоянным клиентам.
- Специальные условия для постоянных клиентов.
- Подбор аналогов.
- Поставку компонентов в любых объемах, удовлетворяющих вашим потребностям.
- Приемлемые сроки поставки, возможна ускоренная поставка.
- Доставку товара в любую точку России и стран СНГ.
- Комплексную поставку.
- Работу по проектам и поставку образцов.
- Формирование склада под заказчика.
- Сертификаты соответствия на поставляемую продукцию (по желанию клиента).
- Тестирование поставляемой продукции.
- Поставку компонентов, требующих военную и космическую приемку.
- Входной контроль качества.
- Наличие сертификата ISO.

В составе нашей компании организован Конструкторский отдел, призванный помогать разработчикам, и инженерам.

Конструкторский отдел помогает осуществить:

- Регистрацию проекта у производителя компонентов.
- Техническую поддержку проекта.
- Защиту от снятия компонента с производства.
- Оценку стоимости проекта по компонентам.
- Изготовление тестовой платы монтаж и пусконаладочные работы.



Тел: +7 (812) 336 43 04 (многоканальный)

Email: org@lifeelectronics.ru