

Micropower high precision series voltage reference



QFN8 1.5x1.5

Features

- Fixed 1.25 V, 1.8 V, 2.048 V, 2.5 V, 3.0 V, 3.3 V, 4.096 V, 5.0 V output voltage
- Ultra low operating current: 3.9 μA (typ.) at 25 °C
- High initial accuracy: $\pm 0.15\%$
- Stable when used with capacitive loads
- Extended temperature range: -40 to +125 °C
- 30 ppm/°C maximum temperature coefficient
- Available in QFN8 1.5x1.5 package

Applications

- Portable equipment
- Data acquisition systems
- Instrumentation
- Medical equipment
- Test equipment

Description

The TS33 family of low power series voltage references is capable of providing stable and precise output voltages with an initial accuracy of 0.15% over an extended temperature range (-40 to +125 °C).

The ultra low operating current is a key advantage for power-restricted designs. In addition, the TS33 is very stable over the entire operating temperature range, making it suitable for high-precision applications.

Available in QFN8 surface mount packages, the TS33 can be designed in applications where space saving is a critical issue.

Maturity status link

TS33

1 Pin configuration

Figure 2. Pin configuration (top view)

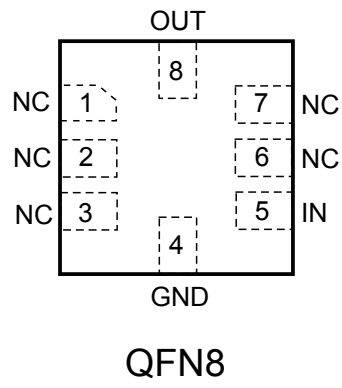

GAMG190120171500MT

2 Maximum ratings

Table 1. Absolute maximum ratings

Symbol	Parameter	Value	Unit
V_{IN}	Maximum input voltage	-0.3 to 7	V
V_{OUT}	Maximum voltage on the output pin	-0.3 to $V_{IN} + 0.3$	V
I_{OUT}	Output short-circuit current (sinking/sourcing)	Internally limited	mA
P_d	Power dissipation ⁽¹⁾	700	mW
T_{stg}	Storage temperature	-65 to +150	°C
ESD	Human body model (HBM)	4	kV
	Charged device model	1000	V
T_{lead}	Lead temperature (soldering) 10 s	260	°C
T_j	Max junction temperature	+150	°C

1. P_d has been calculated with $T_{amb} = 25\text{ °C}$ and $T_{jmax} = 150\text{ °C}$

Note: Absolute maximum ratings are those values beyond which damage to the device may occur. Functional operation under these conditions is not implied.

Table 2. Thermal data

Symbol	Parameter	Value	Unit
R_{thJA}	Thermal resistance junction-ambient	159	°C/W
R_{thJC}	Thermal resistance junction-case	103	°C/W

Table 3. Recommended operating conditions

Symbol	Parameter	Value	Unit
V_{IN}	Operating input voltage range	1.8 to 5.5	V
I_{OUT}	Maximum operating current	±5	mA
T_{oper}	Operating free air temperature range	-40 to +125	°C

3 Typical application

Figure 3. Typical application circuit

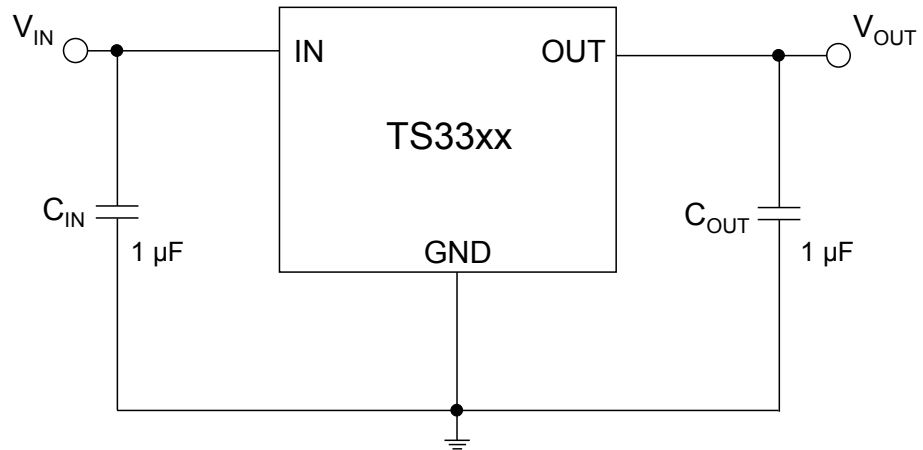

4 Electrical characteristics

$V_{IN} = 5\text{ V}$, $I_{LOAD} = 0\text{ mA}$, $T_{amb} = 25\text{ °C}$ (unless otherwise specified).

Table 4. Electrical characteristics for TS3312

Symbol	Parameter	Test condition	Min.	Typ.	Max.	Unit
V_{IN}	Minimum input voltage	$I_{LOAD} = 0\text{ mA}$ $T_{amb} = 25\text{ °C}$	1.8			V
V_{OUT}	Output voltage	$V_{IN} = 5\text{ V}$		1.25		V
	Initial accuracy	$I_{LOAD} = 0\text{ mA}$ $T_{amb} = 25\text{ °C}$	-0.15		0.15	%
$\Delta V_{OUT}/\Delta T$	Average temperature coefficient	$-40\text{ °C} < T_{amb} < +85\text{ °C}$		9	30	ppm/°C
		$-40\text{ °C} < T_{amb} < +125\text{ °C}$		8	30	
$\Delta V_{OUT}/\Delta V_{IN}$	Line regulation	$V_{IN} = 1.8\text{ V to } 5.5\text{ V}$	-50	6	+50	ppm/V
		$0\text{ °C} < T_{amb} < 70\text{ °C}$		6		
		$-40\text{ °C} < T_{amb} < +85\text{ °C}$		8		
		$-40\text{ °C} < T_{amb} < +125\text{ °C}$		30		
$\Delta V_{OUT}/\Delta I_{LOAD}$	Load regulation	$V_{IN} = 1.8\text{ V}$	-50	6	+50	ppm/mA
		$I_{LOAD} = \pm 5\text{ mA}$ $0\text{ °C} < T_{amb} < 70\text{ °C}$		10		
		$-40\text{ °C} < T_{amb} < +85\text{ °C}$		20		
		$-40\text{ °C} < T_{amb} < +125\text{ °C}$		20		
I_{SC}	Short-circuit current sourcing/sinking			35		mA
I_Q	Quiescent current			3.9	7	μA
		$-40\text{ °C} < T_{amb} < +85\text{ °C}$		4.4	7.5	
		$-40\text{ °C} < T_{amb} < +125\text{ °C}$		4.8	10	
C_{OUT}	Capacitive load		0.1		10	μF
T_{ON}	Turn-on settling time	to 0.1 %, $C_{OUT} = 1\text{ }\mu\text{F}$		2		ms
e_n	Noise floor	$f = 0.1\text{ Hz to } 10\text{ Hz}$		35		μV_{P-P}

Table 5. Electrical characteristics for TS3330

Symbol	Parameter	Test conditions	Min.	Typ.	Max.	Unit
V_{OUT}	Output voltage	$V_{IN} = 5\text{ V}$		3.0		V
	Initial accuracy	$I_{LOAD} = 0\text{ mA}$ $T_{amb} = 25\text{ °C}$	-0.15		0.15	%
$\Delta V_{OUT}/\Delta T$	Average temperature coefficient	$-40\text{ °C} < T_{amb} < +85\text{ °C}$		9	30	ppm/°C
		$-40\text{ °C} < T_{amb} < +125\text{ °C}$		8	30	
$\Delta V_{OUT}/\Delta V_{IN}$	Line regulation	$V_{IN} = 3.2\text{ V to } 5.5\text{ V}$	-50	6	+50	ppm/V
		$0\text{ °C} < T_{amb} < 70\text{ °C}$		6		
		$-40\text{ °C} < T_{amb} < +85\text{ °C}$		8		
		$-40\text{ °C} < T_{amb} < +125\text{ °C}$		30		
$\Delta V_{OUT}/\Delta I_{LOAD}$	Load regulation	$V_{IN} = 3.2\text{ V}$	-50	6	+50	ppm/mA
		$I_{LOAD} = \pm 5\text{ mA}$ $0\text{ °C} < T_{amb} < 70\text{ °C}$		10		
		$-40\text{ °C} < T_{amb} < +85\text{ °C}$		20		
		$-40\text{ °C} < T_{amb} < +125\text{ °C}$		20		
V_{DROP}	Minimum dropout voltage	$V_{IN} = 3.2\text{ V}$ $I_{LOAD} = \pm 5\text{ mA}$ $0\text{ °C} < T_{amb} < 70\text{ °C}$		50	100	mV
		$-40\text{ °C} < T_{amb} < +85\text{ °C}$		70		
		$-40\text{ °C} < T_{amb} < +125\text{ °C}$		75		
		$-40\text{ °C} < T_{amb} < +125\text{ °C}$		80		
		$I_{LOAD} = \pm 2\text{ mA}$ $-40\text{ °C} < T_{amb} < +85\text{ °C}$			70	
I_{SC}	Short-circuit current sourcing/sinking			35		mA
I_Q	Quiescent current			3.9	7	μA
		$-40\text{ °C} < T_{amb} < +85\text{ °C}$		4.4	7.5	
		$-40\text{ °C} < T_{amb} < +125\text{ °C}$		4.8	10	
C_{OUT}	Capacitive load		0.1		10	μF
T_{ON}	Turn-on settling time	to 0.1 %, $C_{OUT} = 1\text{ }\mu\text{F}$		2		ms
e_n	Noise floor	$f = 0.1\text{ Hz to } 10\text{ Hz}$		67		μV_{P-P}

Table 6. Electrical characteristics for TS3333

Symbol	Parameter	Test conditions	Min.	Typ.	Max.	Unit
V_{OUT}	Output voltage	$V_{IN} = 5\text{ V}$		3.3		V
	Initial accuracy	$I_{LOAD} = 0\text{ mA}$ $T_{amb} = 25\text{ °C}$	-0.15		0.15	%
$\Delta V_{OUT}/\Delta T$	Average temperature coefficient	$-40\text{ °C} < T_{amb} < +85\text{ °C}$		9	30	ppm/°C
		$-40\text{ °C} < T_{amb} < +125\text{ °C}$		8	30	
$\Delta V_{OUT}/\Delta V_{IN}$	Line regulation	$V_{IN} = 3.5\text{ V to }5.5\text{ V}$	-50	6	+50	ppm/V
		$0\text{ °C} < T_{amb} < 70\text{ °C}$		6		
		$-40\text{ °C} < T_{amb} < +85\text{ °C}$		8		
		$-40\text{ °C} < T_{amb} < +125\text{ °C}$		30		
$\Delta V_{OUT}/\Delta I_{LOAD}$	Load regulation	$V_{IN} = 3.5\text{ V}$	-50	6	+50	ppm/mA
		$I_{LOAD} = \pm 5\text{ mA}$ $0\text{ °C} < T_{amb} < 70\text{ °C}$		10		
		$-40\text{ °C} < T_{amb} < +85\text{ °C}$		20		
		$-40\text{ °C} < T_{amb} < +125\text{ °C}$		20		
V_{DROP}	Minimum dropout voltage	$V_{IN} = 3.5\text{ V}$ $I_{LOAD} = \pm 5\text{ mA}$		50	100	mV
		$0\text{ °C} < T_{amb} < 70\text{ °C}$		70		
		$-40\text{ °C} < T_{amb} < +85\text{ °C}$		75		
		$-40\text{ °C} < T_{amb} < +125\text{ °C}$		80		
		$I_{LOAD} = \pm 2\text{ mA}$ $-40\text{ °C} < T_{amb} < +85\text{ °C}$			70	
I_{SC}	Short-circuit current sourcing/sinking			35		mA
I_Q	Quiescent current			3.9	7	μA
		$-40\text{ °C} < T_{amb} < +85\text{ °C}$		4.4	7.5	
		$-40\text{ °C} < T_{amb} < +125\text{ °C}$		4.8	10	
C_{OUT}	Capacitive load		0.1		10	μF
T_{ON}	Turn-on settling time	to 0.1 %, $C_{OUT} = 1\text{ }\mu\text{F}$		2		ms
e_n	Noise floor	$f = 0.1\text{ Hz to }10\text{ Hz}$		73		μV_{P-P}

5 Typical performance characteristics

The following plots are referred to the typical application circuit and, unless otherwise noted, at $T_A = 25\text{ }^\circ\text{C}$, $V_{OUT} = 3.0\text{ V}$.

Figure 4. Output voltage vs. temperature

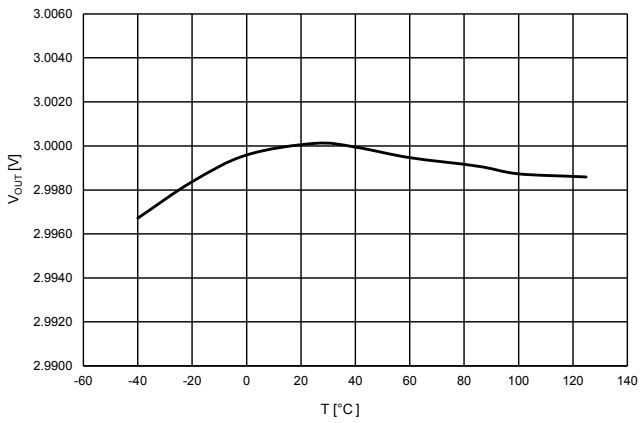

GAMG251120160930MT

Figure 5. Output voltage vs. input voltage

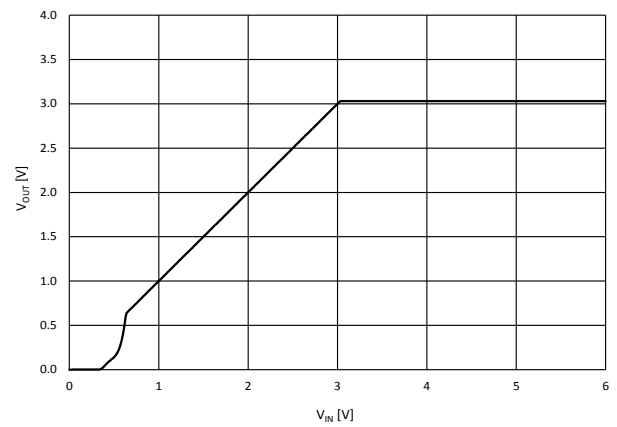

GAMG251120160931MT

Figure 6. Quiescent current vs. input voltage

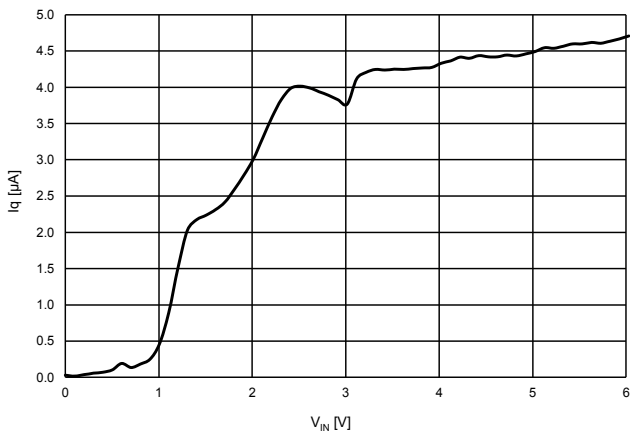

GAMG251120160932MT

Figure 7. Dropout voltage vs. load current

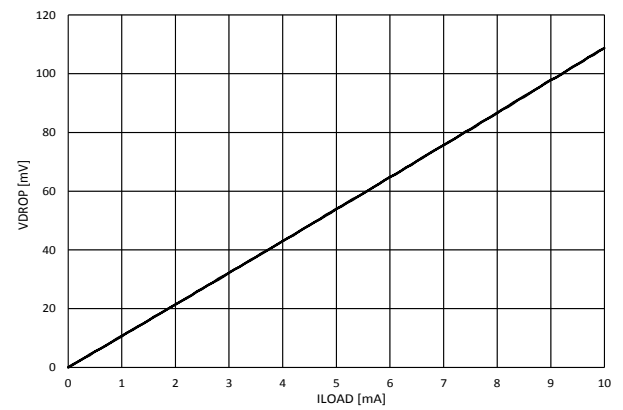

GAMG251120160933MT

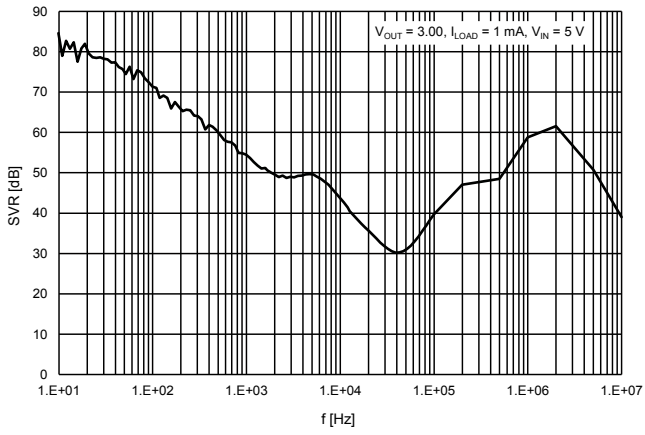
Figure 8. SVR vs. frequency

GAMG251120160934MT

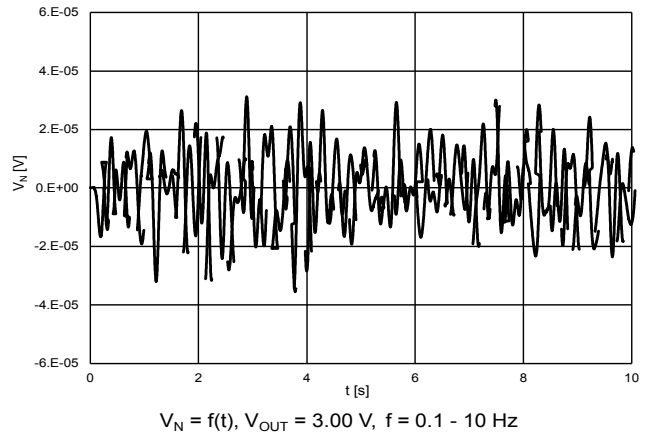
Figure 9. Low frequency noise

GAMG251120160935MT

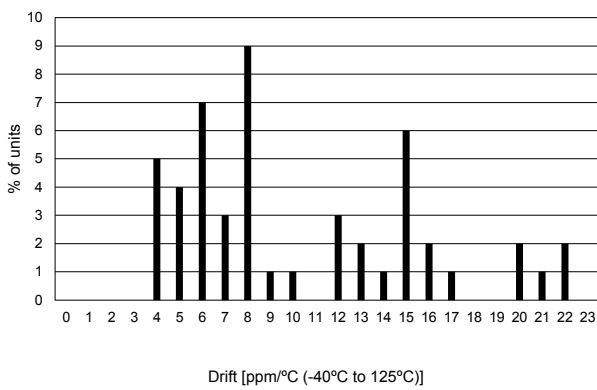
Figure 10. Temperature drift

GAMG251120160936MT

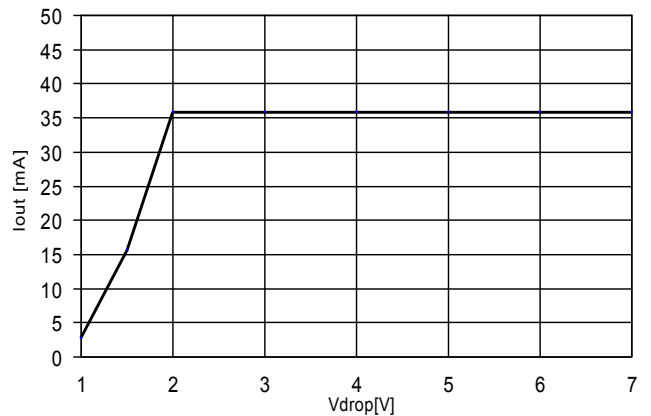
Figure 11. Short-circuit current vs. dropout voltage

 $T = 25\text{ }^{\circ}\text{C}$, $C_{in} = 1\text{ }\mu\text{F}$, $C_{out} = 1\text{ }\mu\text{F}$

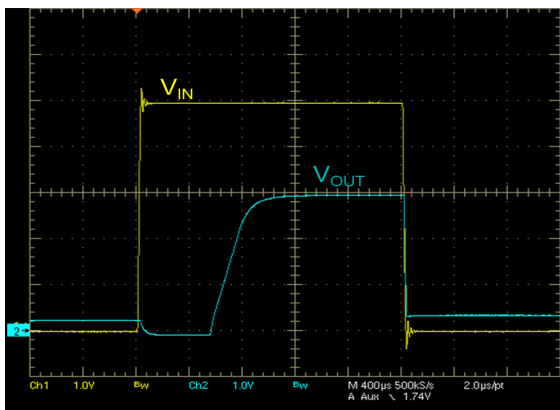
GAMG251120160937MT

Figure 12. Startup transient (no load)

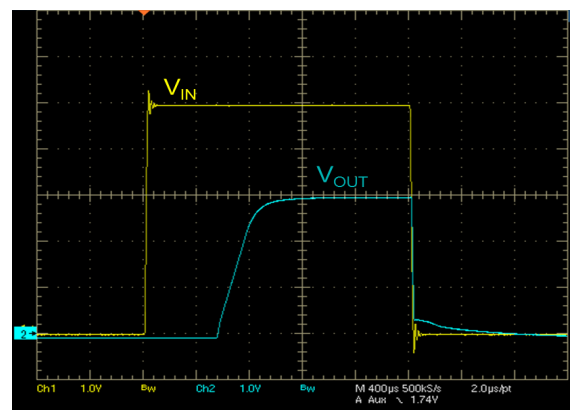
 V_{IN} from 0 to 5V, $V_{OUT}=3\text{V}$, $I_{OUT}=0\text{mA}$, $C_{IN}= C_{OUT}= 1\mu\text{F}$

GAMG251120160938MT

Figure 13. Startup transient ($I_{OUT} = 5\text{ mA}$)

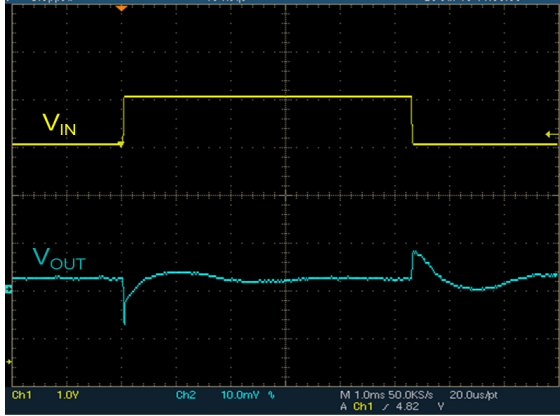
 V_{IN} from 0 to 5V, $V_{OUT}=3\text{V}$, $I_{OUT}=5\text{mA}$, $C_{IN}= C_{OUT}= 1\mu\text{F}$

GAMG251120160939MT

Figure 14. Line transient (no load)

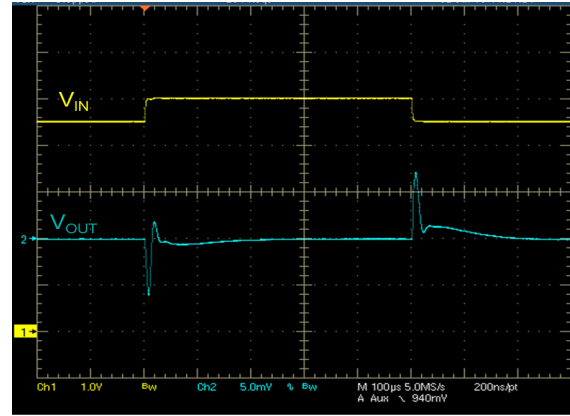
 $V_{IN} = 5V, V_{OUT} = 3V, I_{OUT} = 0mA, C_{OUT} = 1\mu F, \Delta V_{IN} = 500mV$

GAMG251120160940MT

Figure 15. Line transient ($I_{OUT} = 1 mA$)

 $V_{IN} = 5V, V_{OUT} = 3V, I_{OUT} = 1mA, C_{OUT} = 1\mu F, \Delta V_{IN} = 500mV$

GAMG251120160941MT

Figure 16. Load transient ($I_{OUT} = \pm 1 mA$)

 $V_{OUT} = 3V, I_{OUT} = \pm 1mA, C_{IN} = C_{OUT} = 1\mu F$
Figure 17. Load transient ($I_{OUT} = \pm 5 mA$)

 $V_{OUT} = 3V, I_{OUT} = \pm 5mA, C_{IN} = C_{OUT} = 1\mu F$

Figure 18. Short-circuit response

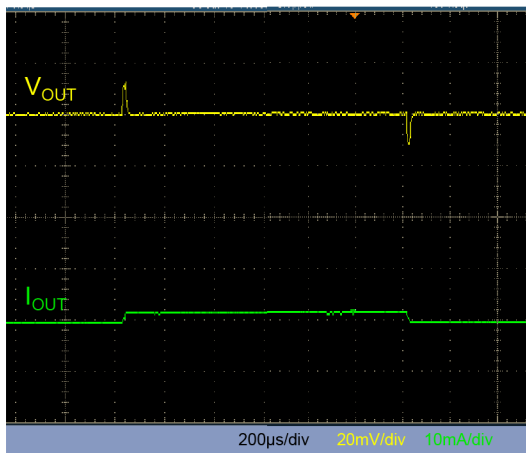
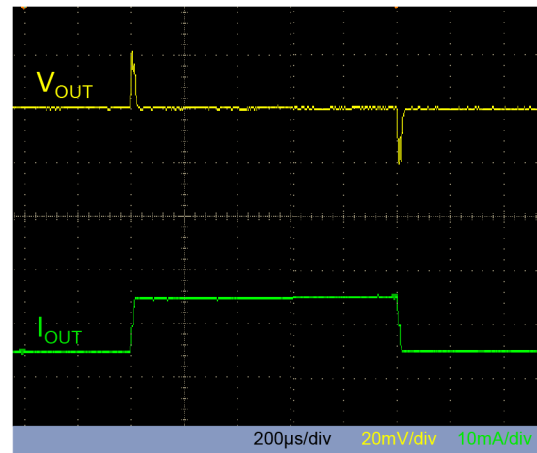
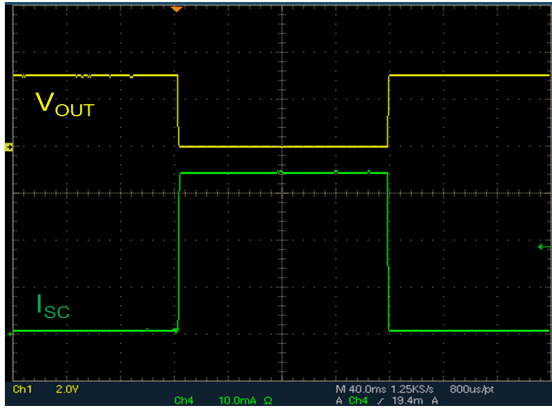

$V_{IN}=5V$, $T=25^{\circ}C$, $C_{IN}=1\mu F$, $C_{OUT}=1\mu F$

GAMG251120160944MT

Figure 19. Stability plan

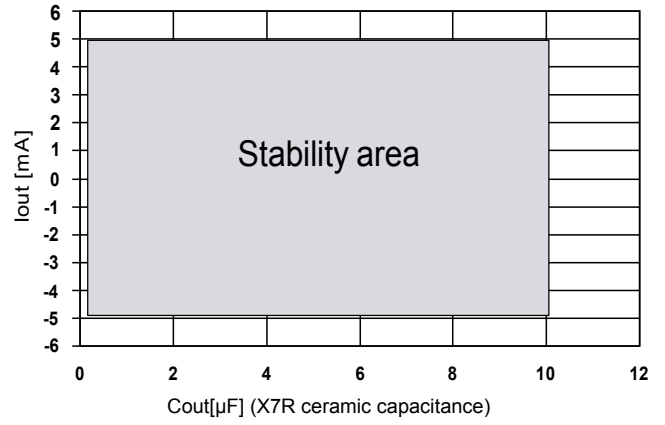

GAMG251120160945MT

6 Package information

In order to meet environmental requirements, ST offers these devices in different grades of ECOPACK® packages, depending on their level of environmental compliance. ECOPACK® specifications, grade definitions and product status are available at: www.st.com. ECOPACK® is an ST trademark.

6.1 QFN8 package information

Figure 20. QFN8 package outline

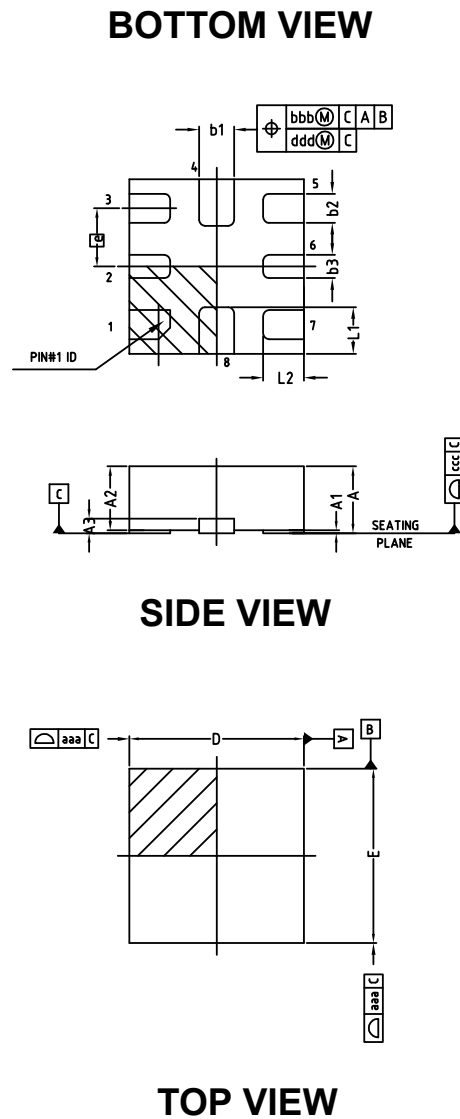

DM00182817_A

Table 7. QFN8 mechanical data

Dim.	mm			Note
	Min.	Typ.	Max.	
A	0.40	-	0.55	4
A1	0.00	-	0.05	12
A2	0.33	0.43	0.53	4
A3		-		4
b1	0.25	0.3	0.35	4.9
b2	0.20	0.25	0.30	
b3	0.15	0.20	0.25	
D	1.40	1.50	1.60	4
e		0.50		4
E	1.40	1.50	1.60	4
L1	0.30	0.40	0.50	4
L2	0.25	0.35	0.45	4
N		8		15

Table 8. QFN8 tolerance of form and position

Symbol	Tolerance of form and position
aaa	0.15
bbb	0.10
ccc	0.08
ddd	0.05
eee	0.10

Figure 21. QFN8 recommended footprint

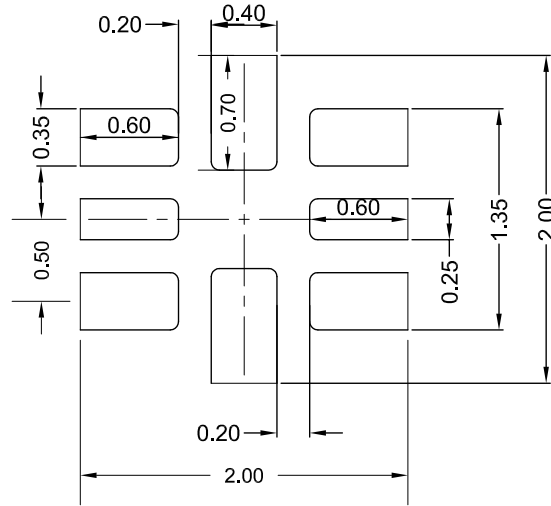

DM00182817_A

7 Ordering information

Table 9. Order codes

Part number	Output voltage (V)	Precision	Package	Temperature range
TS3312AQPR	1.25	±0.15 %	QFN8	-40 to +125 °C
TS3325AQPR ⁽¹⁾	2.5			
TS3330AQPR	3.0			
TS3333AQPR	3.3			

1. *In development.*

Revision history

Table 10. Document revision history

Date	Revision	Changes
05-Sep-2017	1	Initial release.
26-Sep-2018	2	Added new order codes TS3325AQPR and TS3333AQPR in Table 9. Order codes.

Contents

1	Pin configuration	2
2	Maximum ratings	3
3	Typical application	4
4	Electrical characteristics	5
5	Typical performance characteristics	8
6	Package information	12
6.1	QFN-8 package information	12
7	Ordering information	15
	Revision history	16
	Contents	17
	List of tables	18
	List of figures	19

List of tables

Table 1.	Absolute maximum ratings	3
Table 2.	Thermal data	3
Table 3.	Recommended operating conditions	3
Table 4.	Electrical characteristics for TS3312	5
Table 5.	Electrical characteristics for TS3330	6
Table 6.	Electrical characteristics for TS3333	7
Table 7.	QFN8 mechanical data	13
Table 8.	QFN8 tolerance of form and position	13
Table 9.	Order codes	15
Table 10.	Document revision history	16

List of figures

Figure 2.	Pin configuration (top view)	2
Figure 3.	Typical application circuit	4
Figure 4.	Output voltage vs. temperature	8
Figure 5.	Output voltage vs. input voltage	8
Figure 6.	Quiescent current vs. input voltage	8
Figure 7.	Dropout voltage vs. load current	8
Figure 8.	SVR vs. frequency	9
Figure 9.	Low frequency noise	9
Figure 10.	Temperature drift.	9
Figure 11.	Short-circuit current vs. dropout voltage	9
Figure 12.	Startup transient (no load)	9
Figure 13.	Startup transient ($I_{OUT} = 5 \text{ mA}$)	9
Figure 14.	Line transient (no load)	10
Figure 15.	Line transient ($I_{OUT} = 1 \text{ mA}$)	10
Figure 16.	Load transient ($I_{OUT} = +/-1 \text{ mA}$)	10
Figure 17.	Load transient ($I_{OUT} = +/-5 \text{ mA}$)	10
Figure 18.	Short-circuit response	11
Figure 19.	Stability plan	11
Figure 20.	QFN8 package outline	12
Figure 21.	QFN8 recommended footprint.	14

IMPORTANT NOTICE – PLEASE READ CAREFULLY

STMicroelectronics NV and its subsidiaries (“ST”) reserve the right to make changes, corrections, enhancements, modifications, and improvements to ST products and/or to this document at any time without notice. Purchasers should obtain the latest relevant information on ST products before placing orders. ST products are sold pursuant to ST’s terms and conditions of sale in place at the time of order acknowledgement.

Purchasers are solely responsible for the choice, selection, and use of ST products and ST assumes no liability for application assistance or the design of Purchasers’ products.

No license, express or implied, to any intellectual property right is granted by ST herein.

Resale of ST products with provisions different from the information set forth herein shall void any warranty granted by ST for such product.

ST and the ST logo are trademarks of ST. All other product or service names are the property of their respective owners.

Information in this document supersedes and replaces information previously supplied in any prior versions of this document.

© 2018 STMicroelectronics – All rights reserved

Компания «Life Electronics» занимается поставками электронных компонентов импортного и отечественного производства от производителей и со складов крупных дистрибьюторов Европы, Америки и Азии.

С конца 2013 года компания активно расширяет линейку поставок компонентов по направлению коаксиальный кабель, кварцевые генераторы и конденсаторы (керамические, пленочные, электролитические), за счёт заключения дистрибьюторских договоров

Мы предлагаем:

- Конкурентоспособные цены и скидки постоянным клиентам.
- Специальные условия для постоянных клиентов.
- Подбор аналогов.
- Поставку компонентов в любых объемах, удовлетворяющих вашим потребностям.
- Приемлемые сроки поставки, возможна ускоренная поставка.
- Доставку товара в любую точку России и стран СНГ.
- Комплексную поставку.
- Работу по проектам и поставку образцов.
- Формирование склада под заказчика.
- Сертификаты соответствия на поставляемую продукцию (по желанию клиента).
- Тестирование поставляемой продукции.
- Поставку компонентов, требующих военную и космическую приемку.
- Входной контроль качества.
- Наличие сертификата ISO.

В составе нашей компании организован Конструкторский отдел, призванный помогать разработчикам, и инженерам.

Конструкторский отдел помогает осуществить:

- Регистрацию проекта у производителя компонентов.
- Техническую поддержку проекта.
- Защиту от снятия компонента с производства.
- Оценку стоимости проекта по компонентам.
- Изготовление тестовой платы монтаж и пусконаладочные работы.



Тел: +7 (812) 336 43 04 (многоканальный)

Email: org@lifeelectronics.ru