

MC10H646, MC100H646

PECL/TTL-TTL 1:8 Clock Distribution Chip

Description

The MC10H/100H646 is a single supply, low skew translating 1:8 clock driver. Devices in the ON Semiconductor H646 translator series utilize the 28-lead PLCC for optimal power pinning, signal flow through and electrical performance. The single supply H646 is similar to the H643, which is a dual supply 1:8 version of the same function.

The H646 was designed specifically to drive series terminated transmission lines. Special techniques were used to match the HIGH and LOW output impedances to about 7.0 Ω . This simplifies the choice of the termination resistor for series terminated applications. To match the HIGH and LOW output impedances, it was necessary to remove the standard I_{OS} limiting resistor. As a result, the user should take care in preventing an output short to ground as the part will be permanently damaged.

The H646 device meets all of the requirements for driving the 60 MHz and 66 MHz Intel Pentium® Microprocessor. The device has no PLL components, which greatly simplifies its implementation into a digital design. The eight copies of the clock allows for point-to-point clock distribution to simplify board layout and optimize signal integrity.

The H646 provides differential PECL inputs for picking up LOW skew PECL clocks from the backplane and distributing it to TTL loads on a daughter board. When used in conjunction with the MC10/100E111, very low skew, very wide clock trees can be designed. In addition, a TTL level clock input is provided for flexibility. Note that only one of the inputs can be used on a single chip. For correct operation, the unused input pins should be left open.

The Output Enable pin forces the outputs into a high impedance state when a logic 0 is applied.

The output buffers of the H646 can drive two series terminated, 50 Ω transmission lines each. This capability allows the H646 to drive up to 16 different point-to-point clock loads. Refer to the Applications section for a more detailed discussion in this area.

The 10H version is compatible with MECL™ 10H ECL logic levels. The 100H version is compatible with 100K levels.

Features

- PECL/TTL-TTL Version of Popular ECLinPS™ E111
- Low Skew
- Guaranteed Skew Spec
- Tri-State Enable
- Differential Internal Design
- V_{BB} Output
- Single Supply
- Extra TTL and ECL Power/Ground Pins
- Matched High and Low Output Impedance
- Meets Specifications Required to Drive Intel® Pentium® Microprocessors
- Pb-Free Packages are Available*

*For additional information on our Pb-Free strategy and soldering details, please download the ON Semiconductor Soldering and Mounting Techniques Reference Manual, SOLDERRM/D.



ON Semiconductor®

<http://onsemi.com>

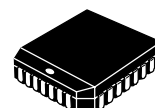

PLCC-28
FN SUFFIX
CASE 776

MARKING DIAGRAM*

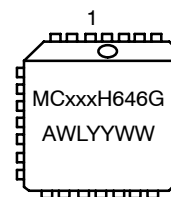

xxx	= 10 or 100
A	= Assembly Location
WL	= Wafer Lot
YY	= Year
WW	= Work Week
G	= Pb-Free Package

*For additional marking information, refer to Application Note AND8002/D.

ORDERING INFORMATION

See detailed ordering and shipping information in the package dimensions section on page 5 of this data sheet.

MC10H646, MC100H646

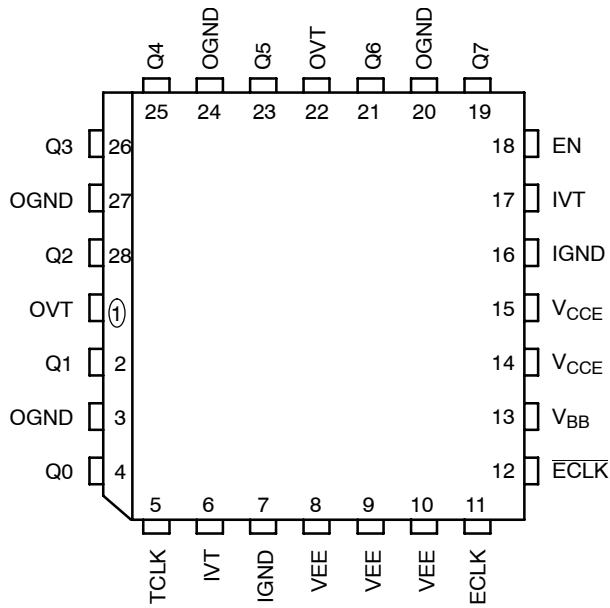

Figure 1. Pinout: PLCC-28
(Top View)

Table 1. PIN DESCRIPTION

PIN	FUNCTION
OGND	TTL Output Ground (0 V)
OVT	TTL Output V_{CC} (+5.0 V)
IGND	Internal TTL GND (0 V)
IVT	Internal TTL V_{CC} (+5.0 V)
V_{EE}	ECL V_{EE} (0 V)
V_{CCE}	ECL Ground (5.0 V)
$\overline{\text{ECLK}}$, $\overline{\text{ECLK}}$	Differential Signal Input (PECL)
V_{BB}	V_{BB} Reference Output
Q0-Q7	Signal Outputs (TTL)
EN	Tri-State Enable Input (TTL)

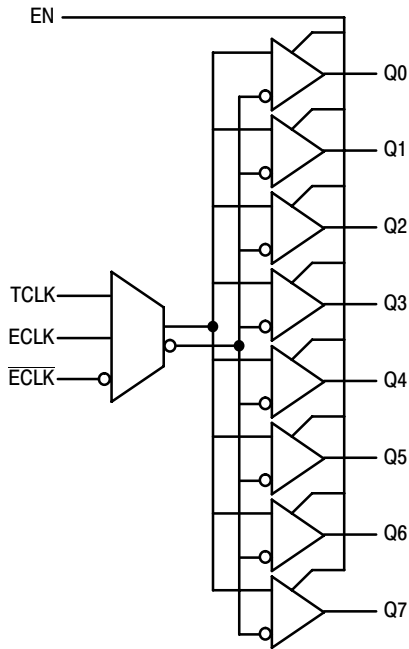

Figure 2. Logic Diagram

Table 2. TRUTH TABLE

TCLK	ECLK	$\overline{\text{ECLK}}$	EN	Q
GND	L	H	H	L
GND	H	L	H	H
H	GND	GND	H	H
L	GND	GND	H	L
X	X	X	L	Z

L = Low Voltage Level; H = High Voltage Level; Z = Tristate

MC10H646, MC100H646

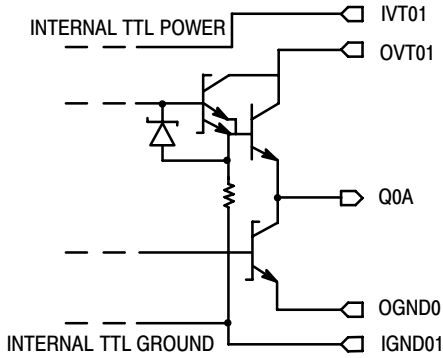

Figure 3. Output Structure

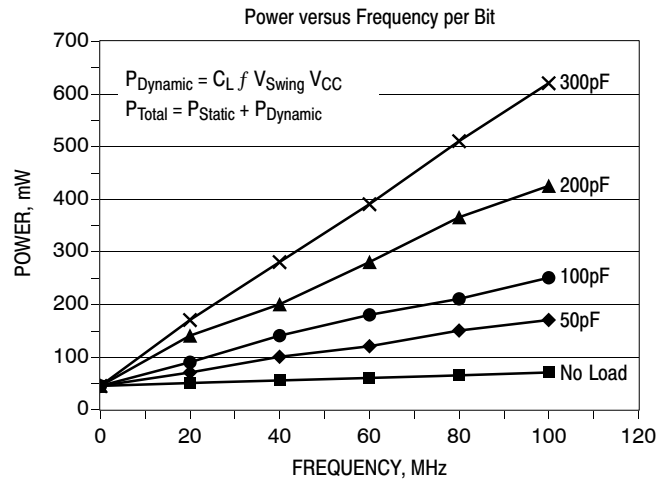

Figure 4. Power versus Frequency (Typical)

Table 3. 10H PECL DC CHARACTERISTICS (IVT = OVT = V_{CCE} = 5.0 V ±5%)

Symbol	Characteristic	Condition	0°C			25°C			85°C			Unit
			Min	Typ	Max	Min	Typ	Max	Min	Typ	Max	
I _{INH}	Input HIGH Current				255			175			175	μA
I _{IL}	Input LOW Current		0.5			0.5			0.5			μA
V _{IH}	Input HIGH Voltage	IVT = IVO = V _{CCE} = 5.0 V (Note 1)	3.83		4.16	3.87		4.19	3.94		4.28	V
V _{IL}	Input LOW Voltage	IVT = IVO = V _{CCE} = 5.0 V (Note 1)	3.05		3.52	3.05		3.52	3.05		3.555	V
V _{BB}	Output Reference Voltage	IVT = IVO = V _{CCE} = 5.0 V (Note 1)	3.62		3.73	3.65		3.75	3.69		3.81	V

NOTE: Device will meet the specifications after thermal equilibrium has been established when mounted in a test socket or printed circuit board with maintained transverse airflow greater than 500 lfm. Electrical parameters are guaranteed only over the declared operating temperature range. Functional operation of the device exceeding these conditions is not implied. Device specification limit values are applied individually under normal operating conditions and not valid simultaneously.

1. ECL V_{IH}, V_{IL} and V_{BB} are referenced to V_{CCE} and will vary 1:1 with the power supply. The levels shown are for IVT = IVO = V_{CCE} = 5.0 V

Table 4. 100H PECL DC CHARACTERISTICS (IVT = OVT = V_{CCE} = 5.0 V ±5%)

Symbol	Characteristic	Condition	0°C			25°C			85°C			Unit
			Min	Typ	Max	Min	Typ	Max	Min	Typ	Max	
I _{INH}	Input HIGH Current				255			175			175	μA
I _{IL}	Input LOW Current		0.5			0.5			0.5			μA
V _{IH}	Input HIGH Voltage	IVT = IVO = V _{CCE} = 5.0 V (Note 2)	3.835		4.12	3.835		4.12	3.835		3.835	V
V _{IL}	Input LOW Voltage	IVT = IVO = V _{CCE} = 5.0 V (Note 2)	3.19		3.525	3.19		3.525	3.19		3.525	V
V _{BB}	Output Reference Voltage	IVT = IVO = V _{CCE} = 5.0 V (Note 2)	3.62		3.74	3.62		3.74	3.62		3.74	V

NOTE: Device will meet the specifications after thermal equilibrium has been established when mounted in a test socket or printed circuit board with maintained transverse airflow greater than 500 lfm. Electrical parameters are guaranteed only over the declared operating temperature range. Functional operation of the device exceeding these conditions is not implied. Device specification limit values are applied individually under normal operating conditions and not valid simultaneously.

2. ECL V_{IH}, V_{IL} and V_{BB} are referenced to V_{CCE} and will vary 1:1 with the power supply. The levels shown are for IVT = IVO = V_{CCE} = 5.0 V

MC10H646, MC100H646

Table 5. DC CHARACTERISTICS (IVT = OVT = V_{CCE} = 5.0 V ±5%)

Symbol	Characteristic	Condition	0°C		25°C		85°C		Unit
			Min	Max	Min	Max	Min	Max	
V _{OH}	Output HIGH Voltage	I _{OH} = 24 mA	2.6	–	2.6	–	2.6	–	V
V _{OL}	Output LOW Voltage	I _{OL} = 48 mA	–	0.5	–	0.5	–	0.5	V
IOS	Output Short Circuit Current	(Note 3)	–	–	–	–	–	–	mA

NOTE: Device will meet the specifications after thermal equilibrium has been established when mounted in a test socket or printed circuit board with maintained transverse airflow greater than 500 lfpm. Electrical parameters are guaranteed only over the declared operating temperature range. Functional operation of the device exceeding these conditions is not implied. Device specification limit values are applied individually under normal operating conditions and not valid simultaneously.

- The outputs must not be shorted to ground, as this will result in permanent damage to the device. The high drive outputs of this device do not include a limiting IOS resistor.

Table 6. TTL DC CHARACTERISTICS (V_T = V_E = 5.0 V ±5%)

Symbol	Characteristic	Condition	0°C		25°C		85°C		Unit
			Min	Max	Min	Max	Min	Max	
V _{IH} V _{IL}	Input HIGH Voltage Input LOW Voltage		2.0	0.8	2.0	0.8	2.0	0.8	V
I _{IH}	Input HIGH Current	V _{IN} = 2.7 V V _{IN} = 7.0 V		20 100		20 100		20 100	μA
I _{IL}	Input LOW Current	V _{IN} = 0.5 V		–0.6		–0.6		–0.6	mA
V _{OH}	Output HIGH Voltage	I _{OH} = –3.0 mA I _{OH} = –24 mA	2.5 2.0		2.5 2.0		2.5 2.0		V
V _{OL}	Output LOW Voltage	I _{OL} = 24 mA		0.5		0.5		0.5	V
V _{IK}	Input Clamp Voltage	I _{IN} = –18 mA		–1.2		–1.2		–1.2	V

NOTE: Device will meet the specifications after thermal equilibrium has been established when mounted in a test socket or printed circuit board with maintained transverse airflow greater than 500 lfpm. Electrical parameters are guaranteed only over the declared operating temperature range. Functional operation of the device exceeding these conditions is not implied. Device specification limit values are applied individually under normal operating conditions and not valid simultaneously.

Table 7. DC CHARACTERISTICS (IVT = OVT = V_{CCE} = 5.0 V ±5%)

Symbol	Characteristic	Condition	0°C		25°C			85°C		Unit
			Min	Max	Min	Typ	Max	Min	Max	
I _{CCL}	Power Supply Current	Total all OVT, IVT, and V _{CCE} pins		185		166	185		185	mA
I _{CCH}				175		154	175		175	mA
I _{CCZ}				210			210		210	

NOTE: Device will meet the specifications after thermal equilibrium has been established when mounted in a test socket or printed circuit board with maintained transverse airflow greater than 500 lfpm. Electrical parameters are guaranteed only over the declared operating temperature range. Functional operation of the device exceeding these conditions is not implied. Device specification limit values are applied individually under normal operating conditions and not valid simultaneously.

MC10H646, MC100H646

Table 8. AC CHARACTERISTICS (IVT = OVT = V_{CC}E = 5.0 V ±5%)

Symbol	Characteristic	Condition	0°C		25°C		85°C		Unit
			Min	Max	Min	Max	Min	Max	
t _{PLH}	Propagation Delay	ECLK to Q TCLK to Q	4.8 5.1	5.8 6.4	5.0 5.3	6.0 6.4	5.6 5.7	6.6 7.0	ns
t _{PHL}	Propagation Delay	ECLK to Q TCLK to Q	4.4 4.7	5.4 6.0	4.4 4.8	5.4 5.9	4.8 5.2	5.8 6.5	ns
t _{SK(O)}	Output Skew	Q0, Q3, Q4, Q7 Q1, Q2, Q5 Q0-Q7		350 350 500		350 350 500		350 350 500	ps
t _{SK(PR)}	Process Skew	ECLK to Q TCLK to Q		1.0 1.3		1.0 1.1		1.0 1.3	ns
t _{SK(P)}	Pulse Skew	Δt _{PLH} - t _{PHL}		1.0		1.0		1.0	ns
t _r , t _f	Rise/Fall Time		0.3	1.5	0.3	1.5	0.3	1.5	ns
t _{PW}	Output Pulse Width	66 MHz @ 2.0 V 66 MHz @ 0.8 V 60 MHz @ 2.0 V 60 MHz @ 0.8 V	5.5 5.5 6.0 6.0		5.5 5.5 6.0 6.0		5.5 5.5 6.0 6.0		ns
t _{Stability}	Clock Stability			± 75		± 75		± 75	ps
F _{MAX}	Maximum Input Frequency			80		80		80	MHz

NOTE: Device will meet the specifications after thermal equilibrium has been established when mounted in a test socket or printed circuit board with maintained transverse airflow greater than 500 lfm. Electrical parameters are guaranteed only over the declared operating temperature range. Functional operation of the device exceeding these conditions is not implied. Device specification limit values are applied individually under normal operating conditions and not valid simultaneously.

- Output skew defined for identical output transitions.
- Process skew is valid for V_{CC} = 5.0 V ±5%.
- Parameters guaranteed by t_{SK(P)} and t_r, t_f specification limits.
- Clock stability is the period variation between two successive rising edges.
- For series terminated lines. See Applications section for F_{MAX} enhancement techniques.
- All AC specifications tested driving 50 Ω series terminated transmission lines at 80 MHz.

ORDERING INFORMATION

Device	Package	Shipping [†]
MC10H646FN	PLCC-28	37 Units / Rail
MC10H646FNG	PLCC-28 (Pb-Free)	37 Units / Rail
MC10H646FNR2	PLCC-28	500 / Tape & Reel
MC10H646FNR2G	PLCC-28 (Pb-Free)	500 / Tape & Reel
MC100H646FN	PLCC-28	37 Units / Rail
MC100H646FNG	PLCC-28 (Pb-Free)	37 Units / Rail
MC100H646FNR2	PLCC-28	500 / Tape & Reel
MC100H646FNR2G	PLCC-28 (Pb-Free)	500 / Tape & Reel

[†]For information on tape and reel specifications, including part orientation and tape sizes, please refer to our Tape and Reel Packaging Specifications Brochure, BRD8011/D.

MC10H646, MC100H646

Resource Reference of Application Notes

- AN1405/D** – ECL Clock Distribution Techniques
- AN1406/D** – Designing with PECL (ECL at +5.0 V)
- AN1503/D** – ECLinPS™ I/O SPiCE Modeling Kit
- AN1504/D** – Metastability and the ECLinPS Family
- AN1568/D** – Interfacing Between LVDS and ECL
- AN1672/D** – The ECL Translator Guide
- AND8001/D** – Odd Number Counters Design
- AND8002/D** – Marking and Date Codes
- AND8020/D** – Termination of ECL Logic Devices
- AND8066/D** – Interfacing with ECLinPS
- AND8090/D** – AC Characteristics of ECL Devices

MC10H646, MC100H646

PACKAGE DIMENSIONS

PLCC-28
FN SUFFIX
PLASTIC PLCC PACKAGE
CASE 776-02
ISSUE E



NOTES:

- DATUMS -L-, -M-, AND -N- DETERMINED WHERE TOP OF LEAD SHOULDER EXITS PLASTIC BODY AT MOLD PARTING LINE.
- DIMENSION G1, TRUE POSITION TO BE MEASURED AT DATUM -T-, SEATING PLANE.
- DIMENSIONS R AND U DO NOT INCLUDE MOLD FLASH. ALLOWABLE MOLD FLASH IS 0.010 (0.250) PER SIDE.
- DIMENSIONING AND TOLERANCING PER ANSI Y14.5M, 1982.
- CONTROLLING DIMENSION: INCH.
- THE PACKAGE BOTTOM MAY BE SMALLER THAN THE PACKAGE TOP BY UP TO 0.012 (0.300). DIMENSIONS R AND U ARE DETERMINED AT THE OUTERMOST EXTREMES OF THE PLASTIC BODY EXCLUSIVE OF MOLD FLASH, TIE BAR BURRS, GATE BURRS AND INTERLEAD FLASH, BUT INCLUDING ANY MISMATCH BETWEEN THE TOP AND BOTTOM OF THE PLASTIC BODY.
- DIMENSION H DOES NOT INCLUDE DAMBAR PROTRUSION OR INTRUSION. THE DAMBAR PROTRUSION(S) SHALL NOT CAUSE THE H DIMENSION TO BE GREATER THAN 0.037 (0.940). THE DAMBAR INTRUSION(S) SHALL NOT CAUSE THE H DIMENSION TO BE SMALLER THAN 0.025 (0.635).

DIM	INCHES		MILLIMETERS	
	MIN	MAX	MIN	MAX
A	0.485	0.495	12.32	12.57
B	0.485	0.495	12.32	12.57
C	0.165	0.180	4.20	4.57
E	0.090	0.110	2.29	2.79
F	0.013	0.019	0.33	0.48
G	0.050 BSC		1.27 BSC	
H	0.026	0.032	0.66	0.81
J	0.020	---	0.51	---
K	0.025	---	0.64	---
R	0.450	0.456	11.43	11.58
U	0.450	0.456	11.43	11.58
V	0.042	0.048	1.07	1.21
W	0.042	0.048	1.07	1.21
X	0.042	0.056	1.07	1.42
Y	---	0.020	---	0.50
Z	2°		10°	
G1	0.410	0.430	10.42	10.92
K1	0.040	---	1.02	---

MC10H646, MC100H646

ECLinPS is a trademark of Semiconductor Components Industries, LLC (SCILLC).

MECL 10H is a trademark of Motorola, Inc.

Pentium is a registered trademark of Intel Corporation.

ON Semiconductor and  are registered trademarks of Semiconductor Components Industries, LLC (SCILLC). SCILLC reserves the right to make changes without further notice to any products herein. SCILLC makes no warranty, representation or guarantee regarding the suitability of its products for any particular purpose, nor does SCILLC assume any liability arising out of the application or use of any product or circuit, and specifically disclaims any and all liability, including without limitation special, consequential or incidental damages. "Typical" parameters which may be provided in SCILLC data sheets and/or specifications can and do vary in different applications and actual performance may vary over time. All operating parameters, including "Typicals" must be validated for each customer application by customer's technical experts. SCILLC does not convey any license under its patent rights nor the rights of others. SCILLC products are not designed, intended, or authorized for use as components in systems intended for surgical implant into the body, or other applications intended to support or sustain life, or for any other application in which the failure of the SCILLC product could create a situation where personal injury or death may occur. Should Buyer purchase or use SCILLC products for any such unintended or unauthorized application, Buyer shall indemnify and hold SCILLC and its officers, employees, subsidiaries, affiliates, and distributors harmless against all claims, costs, damages, and expenses, and reasonable attorney fees arising out of, directly or indirectly, any claim of personal injury or death associated with such unintended or unauthorized use, even if such claim alleges that SCILLC was negligent regarding the design or manufacture of the part. SCILLC is an Equal Opportunity/Affirmative Action Employer. This literature is subject to all applicable copyright laws and is not for resale in any manner.

PUBLICATION ORDERING INFORMATION

LITERATURE FULFILLMENT:

Literature Distribution Center for ON Semiconductor
P.O. Box 5163, Denver, Colorado 80217 USA
Phone: 303-675-2175 or 800-344-3860 Toll Free USA/Canada
Fax: 303-675-2176 or 800-344-3867 Toll Free USA/Canada
Email: orderlit@onsemi.com

N. American Technical Support: 800-282-9855 Toll Free
USA/Canada
Europe, Middle East and Africa Technical Support:
Phone: 421 33 790 2910
Japan Customer Focus Center
Phone: 81-3-5773-3850

ON Semiconductor Website: www.onsemi.com
Order Literature: <http://www.onsemi.com/orderlit>

For additional information, please contact your local Sales Representative

Компания «Life Electronics» занимается поставками электронных компонентов импортного и отечественного производства от производителей и со складов крупных дистрибьюторов Европы, Америки и Азии.

С конца 2013 года компания активно расширяет линейку поставок компонентов по направлению коаксиальный кабель, кварцевые генераторы и конденсаторы (керамические, пленочные, электролитические), за счёт заключения дистрибьюторских договоров

Мы предлагаем:

- Конкурентоспособные цены и скидки постоянным клиентам.
- Специальные условия для постоянных клиентов.
- Подбор аналогов.
- Поставку компонентов в любых объемах, удовлетворяющих вашим потребностям.
- Приемлемые сроки поставки, возможна ускоренная поставка.
- Доставку товара в любую точку России и стран СНГ.
- Комплексную поставку.
- Работу по проектам и поставку образцов.
- Формирование склада под заказчика.
- Сертификаты соответствия на поставляемую продукцию (по желанию клиента).
- Тестирование поставляемой продукции.
- Поставку компонентов, требующих военную и космическую приемку.
- Входной контроль качества.
- Наличие сертификата ISO.

В составе нашей компании организован Конструкторский отдел, призванный помогать разработчикам, и инженерам.

Конструкторский отдел помогает осуществить:

- Регистрацию проекта у производителя компонентов.
- Техническую поддержку проекта.
- Защиту от снятия компонента с производства.
- Оценку стоимости проекта по компонентам.
- Изготовление тестовой платы монтаж и пусконаладочные работы.



Тел: +7 (812) 336 43 04 (многоканальный)

Email: org@lifeelectronics.ru