



TELEDYNE LECROY
Everywhere you look™



Operator's Manual

AP033 Active
Differential Probe

AP033 Active Differential Probe
Operator's Manual

May 2013





© 2013 Teledyne LeCroy, Inc. All rights reserved.

Unauthorized duplication of Teledyne LeCroy documentation materials other than for internal sales and distribution purposes is strictly prohibited. However, clients are encouraged to distribute and duplicate Teledyne LeCroy documentation for their own internal educational purposes.

WaveSurfer, WaveRunner, and Teledyne LeCroy are registered trademarks of Teledyne LeCroy, Inc. Windows is a registered trademark of Microsoft Corporation. Other product or brand names are trademarks or requested trademarks of their respective holders. Information in this publication supersedes all earlier versions. Specifications are subject to change without notice.

Warranty

Teledyne LeCroy warrants this oscilloscope accessory for normal use and operation within specification for a period of one year from the date of shipment. Spare parts, replacement parts and repairs are warranted for 90 days.

In exercising its warranty, Teledyne LeCroy, at its option, will either repair or replace any assembly returned within its warranty period to the Customer Service Department or an authorized service center. However, this will be done only if the product is determined by Teledyne LeCroy's examination to be defective due to workmanship or materials, and the defect is not caused by misuse, neglect, accident, abnormal conditions of operation, or damage resulting from attempted repair or modifications by a non-authorized service facility.

The customer will be responsible for the transportation and insurance charges for the return of products to the service facility. Teledyne LeCroy will return all products under warranty with transportation charges prepaid.

This warranty replaces all other warranties, expressed or implied, including but not limited to any implied warranty of merchantability, fitness or adequacy for any particular purposes or use. Teledyne LeCroy shall not be liable for any special, incidental, or consequential damages, whether in contract or otherwise.

Table of Contents

Safety Instructions	1
Symbols	1
Precautions.....	1
Operating Environment.....	2
Overview	3
Description	3
Applications.....	3
Standard Accessories	4
Optional Accessories	4
Oscilloscope Software Compatibility.....	4
Specifications	5
Operation	8
Connecting the Probe to the Test Instrument	8
Connecting the Probe to the Test Circuit.....	8
Probe Input Loading	10
Grounding the Probe.....	10
Selecting the Proper Range	11
Operation with Teledyne LeCroy Oscilloscopes	12
Adding Offset.....	14
Autobalance	15
Designing Test Fixtures for the AP033 Probe.....	16
Maintenance	17
Cleaning.....	17
Calibration Interval.....	17
Service Strategy.....	17
Troubleshooting	18
Returning a Probe	20
Available Accessories	21

AP033 Active Differential Probe

Matching Procedure for ± 10 Plugs	22
Equipment Required.....	22
Procedure	23
Performance Verification	25
Test Equipment Required.....	25
Preliminary Procedure.....	27
Procedure	27
Adjustment Procedure	35
Introduction.....	35
Test Equipment Required.....	36
Preliminary Procedure.....	38
Procedure	39
Reference Information	48
Differential Mode and Common Mode.....	48
Differential Mode Range and Common Mode Range	48
Common Mode Rejection Ratio	49
Certifications	50
Contact Teledyne LeCroy.....	53

Safety Instructions

This section contains instructions that must be observed to keep this oscilloscope accessory operating in a correct and safe condition. You are required to follow generally accepted safety procedures in addition to the precautions specified in this section. **The overall safety of any system incorporating this accessory is the responsibility of the assembler of the system.**

Symbols

These symbols may appear on the probe body or in this manual to alert you to important safety considerations.



HIGH VOLTAGE, risk of electric shock.



CAUTION of Potential damage to probe or instrument it is connected to, or **WARNING** of potential bodily injury. Attend to the accompanying information to protect against personal injury or damage. Do not proceed until conditions are fully understood and met.



ELECTROSTATIC DISCHARGE (ESD) HAZARD. The probe is susceptible to damage if anti-static measures are not taken.



DOUBLE INSULATION



PROTECTIVE (EARTH) TERMINAL

Precautions

To avoid personal injury, or damage to the probe or test instrument, comply with the following safety precautions.

Use product only as specified.

Connect and disconnect properly. Connect probe to the measurement instrument before connecting the test leads to a circuit/signal being tested.

Use only accessories compatible with the probe. Use only accessories that are rated for the application. Ensure connections between probe input leads and probe accessories are secure before connecting them to a voltage source.

AP033 Active Differential Probe

Do not overload. To avoid electric shock, do not apply any potential that exceeds the maximum rating of the probe and/or the probe accessory, whichever is less. Observe all terminal ratings of the instrument before connecting the probe.

Be careful not to damage the insulation surface when making measurements.

Use only within operational environment listed. Do not use in wet or explosive atmospheres. Keep product surfaces clean and dry. Use indoors only.

Handle with care. Probe accessory tips are sharp. They can puncture skin or cause other bodily injury if not handled properly.

Keep fingers behind the finger guard of the probe accessories.

Do not operate with suspected failures. Before each use, inspect the probe and accessories for any damage such as tears or other defects in the probe body, cable jacket, accessories, etc. If any part is damaged, cease operation immediately and sequester the probe from inadvertent use.

Operating Environment

Only use the product within this operating environment:

Temperature: 0° to 50° C

Humidity: Maximum relative humidity 90 % for temperatures up to 31° C decreasing linearly to 50% relative humidity at 40° C

Altitude: Up to 10,000 ft (3,048 m)

Overview

Description

The AP033 is a wide band differential active probe. The probe features low noise, low input capacitance, high common mode rejection, and FET-buffered inputs in the probe head. User selectable attenuation and offset give the probe flexibility to measure a large range of signal amplitudes. Plug-on attenuator and AC coupling accessories further extend the application range. Interconnect accessories included allow connection to surface mount and through-hole components with minimal signal degradation. The input receptacles in the probe head are compatible with standard 0.025 in. (0.635 mm) square pins. This provides a convenient low cost method of creating device characterization test fixtures.

The probe is powered directly from a Teledyne LeCroy oscilloscope through the ProBus® interface. The ProBus interface also allows local control of the probe through the oscilloscope user interface and remote control through the interface buses, (GPIB, RS-232). The optional ADPPS power supply allows the AP033 to be used with other instruments such as spectrum analyzers, network analyzers, and oscilloscopes without ProBus interface.

Applications

The AP033 is ideal for acquiring high speed differential signals such as those found in disk drive read channels, differential LAN, video, etc. It can also be used with spectrum analyzers to acquire signals in some RF systems (for example, balanced IF mixers in hand held cellular telephones). The high impedance characteristics of both inputs allow the probe to be used as a FET probe to make single-ended measurements in digital systems without introducing a ground loop, as a conventional FET probe would.

Standard Accessories

Hard Case

÷10 Plug-on Attenuator

Plug-on AC Coupler

Probe Connection Accessory Kit:

Flex Lead Set (1)

Mini Clip, 0.8 mm (3)

Mini Clip, 0.5 mm (2)

Ground Lead (1)

Offset Pins, Round (4)

Square Pin Header Strip (1)

Manual, *AP033 Active Differential Probe Operator's Manual*

Optional Accessories

ADPPS Power Supply

Oscilloscope Software Compatibility

For full control functionality of the probe, Teledyne LeCroy LC series oscilloscopes must have software version 8.1.0 or higher loaded; all X-Stream oscilloscopes are compatible. The software version installed in a Teledyne LeCroy oscilloscope can be verified by pressing the SHOW STATUS button on the front panel (where available), then selecting the System menu choice. The probe can be used with earlier versions of software; however, probe offset can only be controlled through the buttons on the probe body. Also, the scale factor will be displayed incorrectly in some modes.

For information on upgrading the software in your oscilloscope, see teledynelecroy.com/support/softwaredownload, or contact your local Teledyne LeCroy representative.

Specifications

Nominal Characteristics

Nominal characteristics describe parameters and attributes that have are guaranteed by design, but do not have associated tolerances.

Input Configuration: True Differential (+ and – Inputs); with shield Ground connector.

Effective Gain¹: X1, X10, ÷10, ÷100²

Input coupling: DC. AC Coupling obtained by installing AC Coupling Adapter.

Differential Mode Range:

(10X Gain):	±40 mV	(÷1 Attenuation)
	±400 mV	(÷10 Attenuation)
	±4 V	(÷100 Attenuation)
(1X Gain):	±400 mV	(÷1 Attenuation)
	±4 V	(÷10 Attenuation)
	±40 V	(÷100 Attenuation)

Common Mode Range:	±4.2 V	(÷1 Attenuation)
	±42 V	(÷10 Attenuation)
	±42 V	(÷100 Attenuation)

Maximum Input Voltage: ±42 V either input from ground

¹ From combination of gain, internal and external attenuation.

² Use external plug-on ÷10 attenuator for ÷100.

Warranted Electrical Characteristics

Warranted characteristics are parameters with guaranteed performance. Unless otherwise noted, tests are provided in the Performance Verification Procedure for all warranted specifications.

LF Gain Accuracy: 2% into 50 Ω load³, measured at 1 kHz with 0 V offset

Common Mode Rejection Ratio⁴ (Probe head grounded, DC Coupled, ÷1 attenuation without external attenuator):	70 Hz	≥ 3160:1	(70 dB)
	1 MHz	≥ 1000:1	(60 dB)
	250 MHz	≥ 5:1	(14 dB)

³ Output impedance 50 Ω, intended to drive 50 Ω. Add uncertainty of termination impedance to accuracy.

AP033 Active Differential Probe

⁴ Teledyne LeCroy measures CMRR with a fixture that connects the probe tip ground to the signal source ground. This method is necessary to obtain a reproducible CMRR measurement. Often, users leave the probe tip ungrounded when measuring high frequency signals. Not grounding the probe tip can actually improve CMRR by allowing some of the common mode signal to be impressed across the entire length of the probe cable instead of from probe tip to probe ground. The CMRR improvement obtained without grounding the probe tip depends on proximity to probe cable ground, and is therefore non-reproducible. Teledyne LeCroy has chosen to use a reproducible method of measurement, rather than obtain a more optimistic measurement.

Typical Electrical Characteristics

Typical characteristics are parameters with no guaranteed performance. Tests for typical characteristics are not provided in the Performance Verification Procedure.

Bandwidth, probe only (-3 dB):	DC to 500 MHz
Risetime, probe only:	≤ 700 ps (÷10 Attenuation) ≤ 875 ps (÷1 Attenuation)
Residual Autobalance Offset (Ref.to input):	≤ 100 μV (÷1 Attenuation) ≤ 1.5 mV (÷10 Attenuation)
Differential Offset Range:	±400 mV (÷1 Attenuation) ± 4 V (÷10 Attenuation) ± 40 V (÷100 Attenuation)
CMRR:	See Figure 1.
Input Resistance (each side to ground):	1 M Ω
Input Capacitance (between inputs): (each side to ground):	< 1.6 pF (÷10 Attenuation) < 3.1 pF (÷1 Attenuation)
Noise (referred to input, 5 to 1000 MHz):	6 nV/√Hz (÷1 Attenuation, 10X Gain) 10 nV/√Hz (÷1 Attenuation, 1X Gain) 60 nV/√Hz (÷10 Attenuation, 10X Gain) 115 nV/√Hz (÷10 Attenuation, 1X Gain)
Output Impedance:	50 Ω nominal, intended to drive 50 Ω
Harmonic Distortion (3rd order distortion): (3rd order intercept):	-52 dB below fundamental (200 mV _{p-p} output at 100 MHz) +15 dBm (at 100 MHz measured at output)
AC Coupling LF Cutoff (-3dB):	16 Hz

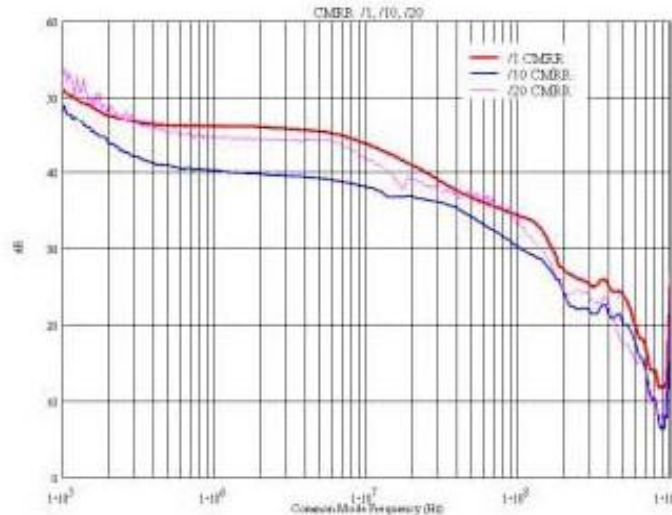

Figure 1, Typical CMRR Graphs

General Characteristics

Temperature: 0° to 50° C Operating
-40° to 75° C Storage

Input Connectors: Compatible with 0.025" (0.635 mm) square pins.
0.036" (0.91 mm) maximum diameter (for round pins)

Power Requirements: Powered from oscilloscope through ProBus interface
or with ADPPS power supply.

Dimensions

Control Housing: Length: 3.625 in (9.2 cm)
Width: 1.50 in (3.8 cm)
Height: 1.00 in (2.5 cm)

Head: Length: 4.0 in (10.1 cm) w/o Attenuator or AC Coupler
Width: 2.25 in (2.25 cm)
Height: 0.625 in (1.6 cm)

Cable: Length: 42 in (106 cm)
Diameter: 0.275 in (7.0 mm)

Weight: Probe only: 6.4 oz (0.18 kg)
Shipping: 2 lbs, 8.4 oz (1.15 kg)

Operation



CAUTION: The input circuits in the AP033 incorporate components that protect the probe from damage resulting from electrostatic discharge (ESD). Keep in mind that this is an active probe, and it should be handled carefully to avoid damage. When using the AP033, you are advised to take precautions against potential instrument damage due to ESD.

Connecting the Probe to the Test Instrument

When using the AP033 Active Differential Probe with a Teledyne LeCroy Oscilloscope equipped with ProBus, attach the probe output connector to the oscilloscope input connector. The oscilloscope will recognize the probe, set the oscilloscope input termination to 50 Ω , and activate the probe control functions in the user interface.

To use the AP033 Active Differential Probe with instrumentation not equipped with a ProBus interface, it is necessary to use the ADPPS Power Supply. Attach the ADPPS connector to the probe output connector. The output connector of the ADPPS is a standard male BNC that can be directly connected to another instrument. If necessary, the output of the ADPPS can be interconnected with a 50 Ω coaxial cable. To minimize the effect of skin loss, this cable should be 1 m or less in length. The AP033 Active Differential Probe is designed to drive a 50 Ω load. The gain will be uncalibrated if the output is not correctly terminated. If you are using the probe with an instrument with a high input impedance, place a 50 instrument input before attaching the ADPPS..

Connecting the Probe to the Test Circuit

At the probe tip, two inputs and a ground connection are available for connecting the probe to a circuit under test. For accurate measurements, both the + and – inputs must always be connected to the test circuit. The ground connection is optional. Positive voltages applied to the + input relative to the – input will deflect the oscilloscope trace toward the top of the screen.

Positive voltages applied to the + input relative to the – input will deflect the oscilloscope trace toward the top of the screen.

To maintain the high performance capability of the probe in measurement applications, user care in connecting the probe to the test circuit. Increasing the parasitic capacitance or inductance in the input paths may introduce a “ring,” or slow the rise time of fast signals. To minimize these effects, use the shortest length possible when connecting the probe to the circuit under test. Input leads that form a large loop area (even shielded coaxial cables) will pick up any radiated magnetic field that passes through the loop, and may induce noise in the probe inputs. Because this signal will appear as a differential mode signal, the probe’s common mode rejection will not remove it. You

can greatly reduce this effect by using short interconnection leads, and twisting them together to minimize the loop area.

High common mode rejection requires precise matching of the relative gain or attenuation in the + and – input signal paths. Mismatches in additional parasitic capacitance, inductance, delay, and a source impedance difference between the + and – signal paths will lower the common mode rejection ratio. Therefore, it is desirable to use the same length and type of wire and connectors for both input connections. When possible, try to connect the inputs to points in the circuit with approximately the same source impedance.

If AC coupling is desired, install the AC coupling accessory on the probe tip before connecting it to the test circuit. The low-frequency cutoff (–3 dB point) of the AC coupler is approximately 16 Hz.

If the voltage in the test circuit requires more than $\div 10$ attenuation, add the external $\div 10$ attenuator to the probe tip. If using both the external attenuator and AC coupler, install the attenuator on the probe tip first, then install the AC coupler on the attenuator input.

In addition to being compatible with the included lead set, the probe input connectors will mate with standard 0.025 in. (0.635 mm) square pins in any rotational orientation. To avoid damaging the input connectors, do not attempt to insert connectors or wire larger than 0.036 in. (0.91 mm) in diameter. Avoid rotating square pins after they are inserted into the input connectors.

The included accessories simplify the task of connecting the probe to the test circuit:

- Use the small (0.5 mm) mini clips with the flexible lead set when connecting to fine-pitch surface mount IC leads.
- Use the larger (0.8 mm) mini clips to connect to through-hole leaded components.
- Use the offset round pins for hand-held probing applications. Reposition the pins by rotating them to obtain the required spacing.

Probe Input Loading

Attaching any probe to a test circuit will add some loading. In most applications, the high impedance of the AP033 Active Differential Probe inputs imparts an insignificant load to the test circuit. However at very high frequencies, the capacitive reactance of the probe's input capacitance may load the circuit enough to affect measurement accuracy. The equivalent model of the probe input circuits is shown below:

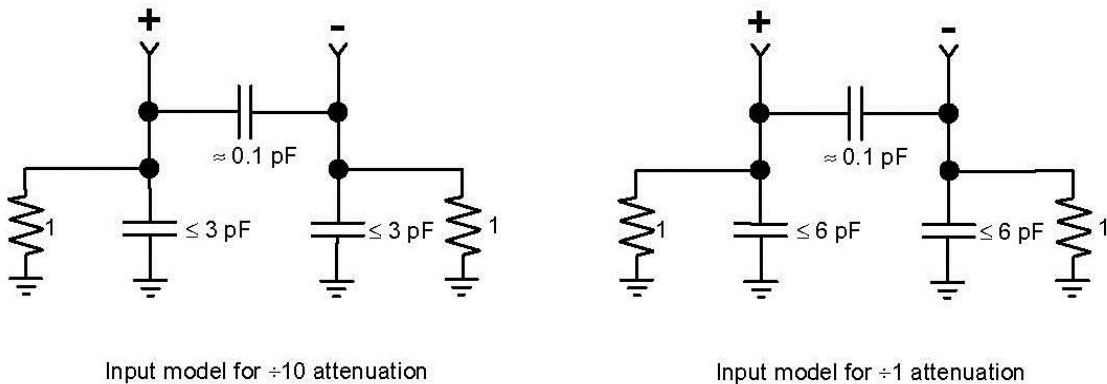

Figure 2, AP033 Equivalent Input Model

Grounding the Probe

The single lead along with one of the larger (0.8 mm) mini clips can be used to ground the probe to the test circuit. Insert the pin end of the lead into the receptacle marked:

CAUTION: Do not use the attenuator encoding receptacle (unmarked socket near the – input) to ground the probe. Connection to the encoding receptacle will not provide adequate grounding and may result in an incorrect effective gain indication.

In many cases it is not necessary to ground the probe to the circuit under test. However, if the test circuit is isolated from earth ground, it is usually necessary to connect the probe ground to a point in the circuit. Grounding test circuits that are referenced to earth ground may improve the fidelity of high frequency components in the waveforms. The potential for improvement with grounding will vary depending on the common mode source impedance. However, connecting the probe ground to a circuit that is referenced to earth ground can create a ground loop that may add noise to low amplitude signals. The rejection of high frequency common mode signals is improved when the probe head is ungrounded.

The best recommendation for connecting or not connecting the probe ground is to try both configurations and select the one that performs the best.

NOTE The AP033 Active Differential Probe transmits the measured signal differentially through the probe cable. This essentially eliminates signal degradation from ground loop effects within the probe. However, creating a ground loop may introduce signal distortions in the test circuit itself, or in any coaxial cable between the ADPPS power supply and the test instrument.

Selecting the Proper Range

The AP033 has two independent controls that set the common mode range and equivalent volts/division. The probe gain can be set to x1 or x10. The gain control (GAIN) only affects the differential mode range of the probe. A separate input attenuator control (ATTEN) sets the probe input attenuator to either $\div 1$ or $\div 10$. See Figure 3.

Figure 3, AP033 Block Diagram

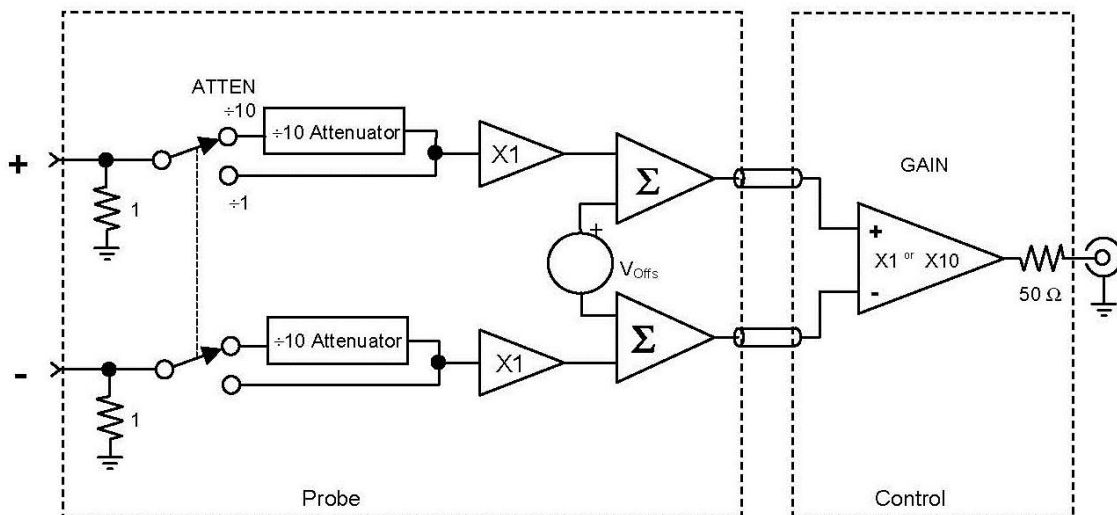

The attenuator is located at the probe input and, therefore, affects both the differential mode and common mode ranges. (Refer to the Reference Section for definitions of Common Mode and Differential Mode.) By using the plug-on attenuator, you can extend the attenuation range to $\div 100$. The maximum ranges are given in Table 1.

AP033 Active Differential Probe

Table 1, AP033 Dynamic ranges and input capacitance at different attenuator settings

	$\div 1$ Attenuation	$\div 10$ Attenuation	$\div 100$ Attenuation
Common Mode Range	• ± 4.2 V	• ± 42 V •	± 42 V
Differential Mode Range with x1 Gain*	• ± 400 mV •	± 4 V •	± 40 V
Differential Mode Range with x10 Gain*	• ± 40 mV •	± 400 mV •	± 4 V
Input Capacitance, each side to Ground	6.0 pF	3.0 pF	1.9 pF
Input Capacitance each side to Ground with AC Coupler	7.3 pF	4.3 pF	3.2 pF

*Offset moves the center point of this range.

When you are using a differential probe or amplifier, be careful not to exceed the common mode range. Because the common mode signal is rejected by the probe, and not displayed, changes in the amplitude of the common mode component are not apparent. Exceeding the common mode range may introduce distortion into the AP033 output. To reduce the possibility of errors caused by exceeding the common mode range, the probe monitors the input voltage. If the common mode range is exceeded when the $\div 1$ input attenuator is selected, the probe will automatically switch to the $\div 10$ attenuator. If the voltage on either input exceeds 55 volts, both the $\div 1$ and $\div 10$ attenuator lights will alternately flash to alert the user to the over-range condition. There are two combinations which result in x1 effective gain. A $\div 10$ attenuation with x10 gain results in higher common mode range and lower input capacitance, but it increases the noise referred to the input. Conversely, $\div 1$ attenuation with x1 gain reduces the noise at the expense of less common mode range and greater input capacitance.

Circuitry in the probe decodes the effective gain of the probe based on the settings of the gain, internal attenuation and the presence of the external attenuator. The resulting effective gain is displayed on the probe front panel.

Operation with Teledyne LeCroy Oscilloscopes

When the AP033 probe is connected to a Teledyne LeCroy oscilloscope equipped with the ProBus interface, the displayed scale factor and measurement values will be adjusted to account for the effective gain of the probe.

When the AP033 probe is first connected to the oscilloscope, the following message will appear: "WARNING: Probe offset buttons are locked". This is to alert the user that offset control must be made through the oscilloscope, rather than through the buttons located on the probe. It does not indicate a failure in the probe or oscilloscope.

With oscilloscope software versions 7.6.0 and higher, the probe gain, internal attenuation, and offset can be conveniently controlled through the oscilloscope's user interface. The common mode range is also displayed. Manual control through the oscilloscope user interface can be found in the COUPLING menu or the Channel dialog of the channel to which the probe is connected. The appearance and functionality of the control menu has changed with incremental versions of the oscilloscope software.

With software versions 8.1.0 and higher, there are two modes of gain control: Auto and Manual. The oscilloscope defaults to Auto mode when the probe is first attached. In Auto mode, the VOLTS/DIV knob controls the oscilloscope's scale factor, AP033 gain, and AP033 attenuation to give the full available dynamic range: 200 $\mu\text{V}/\text{div}$ to 1 V/div (without external attenuator), or 2 mV/div to 10 V/div (with external $\div 10$ attenuator installed). Some of the transitions in scale factor will result in a change of the attenuation in the AP033 probe. The common mode range, input capacitance, and noise level of the probe will change with the probe attenuator setting. For Volts/Div settings which can be produced with more than one combination of probe gain and attenuation settings, Auto mode selects the combination which results in greater common mode range and lower input capacitance.

In some situations, you may wish to select probe settings optimized for the lowest noise performance with lower common mode range. Likewise, you may require that the probe not change input capacitance, noise, or common mode range as you change the VOLTS/DIV setting. These requirements can be met by setting the probe to Manual gain control mode. When set to Manual mode, the dynamic range of the VOLTS/DIV knob is limited to the scale factors that can be obtained without changing the AP033 gain or attenuation. Thus in Manual gain control mode, only the scale factor of the oscilloscope will be changed. In this mode, dedicated menu boxes are displayed for Probe Attenuation and Probe Gain. (Refer to Figure 3). The available values that appear in the Probe Atten menu box will change depending on the presence of the external attenuator. When the external $\div 10$ attenuator is not installed, $\div 10$ and $\div 1$ will be displayed. With the external $\div 10$ attenuator, only $\div 100$ will be displayed. In software versions 8.1.0 and higher, the channel OFFSET knob will control the probe offset, rather than the offset at the oscilloscope input. The OFFSET buttons on the probe body are disabled.

The Coupling Menu refers to the probe input. The common mode dynamic range (CMDR) for the selected probe gain and attenuation settings are displayed in the Probe Attenuation menu. In some versions of software, the input capacitance from each input to ground is also displayed.

When using the AP033 with the ADPPS power supply on oscilloscopes without a ProBus interface, use Table 2 to select the desired effective volts per division scaling.

AP033 Active Differential Probe

Table 2, Recommended oscilloscope settings to obtain desired equivalent Volts/Division

Equivalent Scale Factor	Oscilloscope Scale Factor	AP033 Attenuation	AP033 Gain	Common Mode Range	Differential Mode Range	Maximum Offset	Input Noise (nV/√Hz)
100 μV/Div	1 mV/Div	÷1	X10 •	±4.2 V •	±40 mV •	±400 mV	6
200 μV/Div	2 mV/Div	÷1	X10 •	±4.2 V •	±40 mV •	±400 mV	6
500 μV/Div	5 mV/Div	÷1	X10 •	±4.2 V •	±40 mV •	±400 mV	6
1 mV/Div	10 mV/Div	÷1	X10 •	±4.2 V •	±40 mV •	±400 mV	6
2 mV/Div	20 mV/Div	÷1	X10 •	±4.2 V •	±40 mV •	±400 mV	6
5 mV/Div	50 mV/Div	÷1	X10 •	±4.2 V •	±40 mV •	±400 mV	6
10 mV/Div	100 mV/Div	÷1	X10 •	±4.2 V •	±40 mV •	±400 mV	6
20 mV/Div	20 mV/Div	÷10	X10 •	±42 V •	±400 mV •	±4 V	60
50 mV/Div	50 mV/Div	÷10	X10 •	±42 V •	±400 mV •	±4 V	60
100 mV/Div	100 mV/Div	÷10	X10 •	±42 V •	±400 mV •	±4 V	60
200 mV/Div	20 mV/Div	÷10	X1 •	±42 V •	±4 V •	±4 V	115
500 mV/Div	50 mV/Div	÷10	X1 •	±42 V •	±4 V •	±4 V	115
1 V/Div	100 mV/Div	÷10	X1 •	±42 V •	±4 V •	±4 V	115
2 V/Div	20 mV/Div	÷100 ¹	X1 •	±42 V •	±40 V •	±40 V	1150
5 V/Div	50 mV/Div	÷100 ¹	X1 •	±42 V •	±40 V •	±40 V	1150
10 V/Div	100 mV/Div	÷100 ¹	X1 •	±42 V •	±40 V •	±40 V	1150

¹ ÷100 attenuation obtained using the external ÷10 attenuator. The probe is automatically set to ÷10 internally when the external attenuator is installed. The internal ÷1 attenuator cannot be selected when the external ÷10 attenuator is installed.

Adding Offset

The AP033 has true differential offset capability. This allows you to remove a DC bias voltage from the differential input signal while maintaining DC coupling. By using probe offset rather than the “position” control on the oscilloscope, the full dynamic range of the probe remains centered around the offset level.

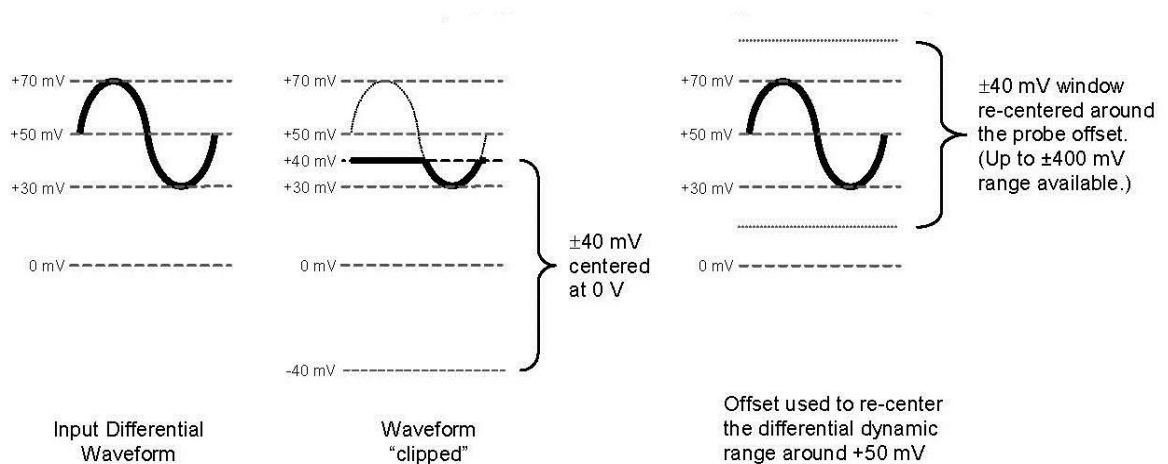

Figure 4, Effect of Differential Offset

When the AP033 is used with a Teledyne LeCroy oscilloscope equipped with a ProBus interface and software versions 7.6.0 to 8.0.0, the probe offset must be controlled through either the Probe Offset menu selection in the COUPLING screen, or the buttons on the probe body. The channel OFFSET control does not change the probe offset and, therefore, should not be used.

When used with the ADPPS Power Supply on instruments that lack ProBus support, offset can be controlled with the buttons on the front panel. The offset can be returned to zero at any time by briefly pressing the \uparrow and \downarrow OFFSET buttons at the same time. Pressing and holding the \uparrow and \downarrow OFFSET buttons for more than two seconds will initiate an Autobalance cycle.

Autobalance

The AP033 incorporates an Autobalance function to remove the DC offset from the output. Autobalance must be invoked by you. When power is first applied, the probe will return to the internal values resulting from the last Autobalance cycle. For Autobalance to function properly, all signals must be removed from the input.

After several minutes of warm up, or when the probe is exposed to a large shift in ambient temperature, some DC offset drift may occur from thermal effects in the amplifier circuitry. To initiate an Autobalance cycle, remove the probe from the test circuit and select AUTOBALANCE from the oscilloscope's COUPLING menu for the channel the probe is connected to. If the probe is being used with the ADPPS power supply, remove the input signal, and push and hold both the OFFSET buttons for two seconds. The AP033 output must be terminated into 50 Ω for successful Autobalance.

AP033 Active Differential Probe

Upon successful completion of the Autobalance cycle, all four of the **EFFECTIVE GAIN** indicators will be briefly illuminated. If an input signal is present during auto balancing and the routine fails, the **EFFECTIVE GAIN** indicators will not illuminate. The probe will then revert to the offset values that resulted from the last successful completion of the Autobalance cycle. In many situations, this will be adequate to make routine measurements.

Designing Test Fixtures for the AP033 Probe

Often it is desirable to connect the probe directly to user fabricated test fixtures, such as those used for semiconductor characterization. To facilitate use with custom test fixtures, the input receptacles of the AP033 probe are compatible with commercially available 0.025 in. (0.635 mm) square pins. The receptacles do not require a specific rotational alignment for the square pin. The dimensions listed below can be used as a layout guide for a test fixture circuit board. The recommended insertion depth of the pins is 0.100 in. (2.5 mm) to 0.200 in. (5.0 mm).

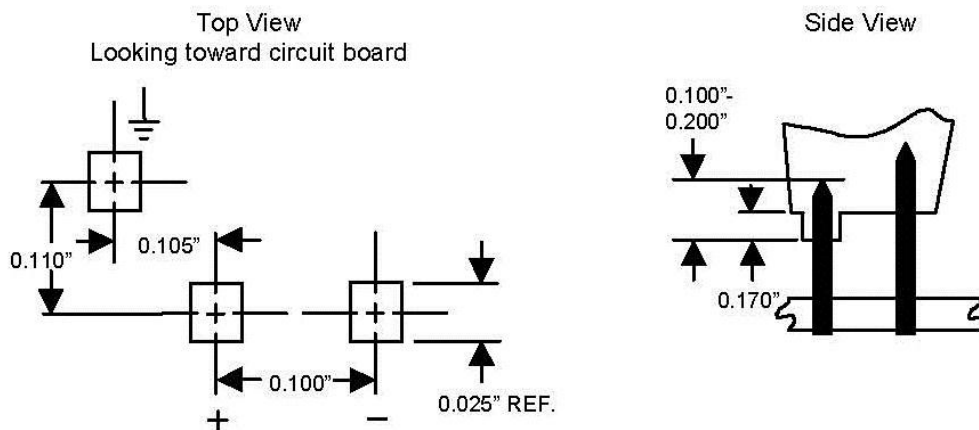

Figure 5, Layout dimensions for test fixtures

Maintenance

This probe is a high quality, precision instrument. To maintain accuracy and signal fidelity, mechanical shock should be avoided, as well as damage to the cable through excessive bending.

To achieve the small 2.5 mm tip size, the input tip diameter is narrower than those in larger probes. Avoid placing excessive force sideways on the tip. Should the tip become damaged, it may be replaced. Other maintenance and component replacement should be referred to qualified personnel.

Cleaning

The outside of the probe should be cleaned with a soft cloth dampened with either deionized / distilled water or isopropyl alcohol. Allow the surface to dry completely before returning the probe to service. Never immerse the probe in any liquid.

Calibration Interval

To guarantee accurate performance, you should have the probe calibrated every 12 months. Avoid exposing the probe to extreme mechanical shock and excessive bending of the cable because these may alter the calibration.

Service Strategy

The AP033 circuits utilize fine pitch surface mount devices; it is, therefore, impractical to attempt component-level repair in the field. Defective probes must be returned to a Teledyne LeCroy service facility for diagnosis and exchange. A defective probe under warranty will be replaced with a factory refurbished probe. A probe that is not under warranty can be exchanged for a factory refurbished probe. A modest fee is charged for this service. The defective probe must be returned in order to receive credit for the probe core.

Troubleshooting

If the probe is not operating properly the problem may be the way in which it is used. Before assuming the probe is defective, perform the following troubleshooting procedures.

A. Trace Off Scale

This is typically caused by improper offset setting, or by an input signal that exceeds the probe differential or common mode range.

1. Remove the input signal from the probe, return the offset to zero, and Autobalance the probe. Does the trace return to approximately the center of the graticule? If not, proceed to step 7.
2. Set the oscilloscope calibrator to output a 100-mV 1-kHz square wave. Using the flex lead set, connect the probe + input to the calibrator output signal, leave the - input open. Set the oscilloscope to 50 mV/div and 500 μ s/div. Is the displayed waveform a 100-mV 1-kHz square wave with the correct polarity?
3. Repeat step 2 with the - input connected to the calibrator and the + input left open. In this case, the displayed waveform should be inverted.
4. Connect both the + input and - input to the calibrator output. Is the trace approximately a flat line near zero volts?
5. If steps 1 to 4 give the correct results, the problem is likely a result of the input signal exceeding the differential or common mode range.
6. Connect both the + input and - input to one of the two input signals. If the trace is off scale, the input signal is probably exceeding the common mode range. Repeat with the other input signal.
7. Is a ProBus Power Supply Overload error message displayed? If so, remove all other ProBus accessories from the oscilloscope. Is the message still displayed? If so, remove the AP033. Is the message still displayed? If so, the oscilloscope should be returned for service.
8. If, after removing the AP033, the Power Supply Overload error message is not displayed, the problem may be either the probe or the oscilloscope. Repeat the test with a different ProBus accessory. If the message does not return with a different accessory, the AP033 may be defective and should be returned for service.

B. Incorrect Frequency Response

Possible causes are a defective probe or oscilloscope, poor connections, or poor grounding.

1. Verify that the BW limiting of the oscilloscope is off.
2. Connect the probe to another oscilloscope. If the probe now measures properly, the problem may be in the oscilloscope.
3. If the probe behaves as if it is ac-coupled at high frequency, check for an open input connection.
4. Poor frequency or transient response and AC gain errors may result when one of the two input connections is open.
5. Excessive “ring” and other transient problems can result from excessive input lead length. To test this, shorten the input leads to less than 1 cm. If the transient response changes significantly, the lead parasitics are the cause.

C. DC Errors

Incorrect DC gain requires recalibration or factory repair. This can be determined by completing the gain checks in the Performance Verification Procedure.

1. Extremely high source resistance will result in DC gain errors. Check the probe accuracy with the oscilloscope calibrator signal.
2. Verify that the probe is not being overdriven into clipping for its current gain setting.
3. Excessive offset can result from large changes in ambient temperature. Remove the input signal from the probe and repeat the Autobalance cycle. With the Offset set to zero, did the trace return to the center of the graticule?

D. Poor Common Mode Rejection

Use the 1-kHz calibrator signal from the oscilloscope to check common mode rejection. With both the + input and – input connected to the calibrator signal, a flat line at zero volts should be seen on the graticule.

1. Check the probe with the plug-on attenuator installed and removed. If excessive common mode signal appears only when the attenuator is present, the attenuator may need to be rematched to the probe. Use the procedure listed in this section to match the attenuator.
2. If the common mode signal appears when the probe is connected to the test circuit, but not when it is attached to the calibrator, the problem may be caused by large mismatches in the source impedance. Try connecting both inputs to one of the input signals in the test circuit, then the other. If the common mode signal disappears, try probing lower impedance points within the circuit.

Returning a Probe

Return a probe for calibration or service by contacting your local Teledyne LeCroy sales representative. They tell you where to return the product. All returned products should be identified by both **model** and **serial number**. Provide your name and contact number, and a description of the defect or failure (if possible).

Products returned to the factory require a **Return Material Authorization (RMA)** acquired by contacting your nearest Teledyne LeCroy sales office, representative or the North America Customer Care Center.

Return shipment should be prepaid. Teledyne LeCroy cannot accept COD or Collect Return shipments. We recommend air-freighting.

1. Contact your local Teledyne LeCroy sales or service representative to obtain a Return Material Authorization.
2. Remove all accessories from the probe. Do not include the manual.
3. Pack the probe in its case, surrounded by the original packing material (or equivalent) and box.
4. Label the case with a tag containing
 - The RMA
 - Name and address of the owner
 - Probe model and serial number
 - Description of failure
5. Package the probe case in a cardboard shipping box with adequate padding to avoid damage in transit.
6. Mark the outside of the box with the shipping address given to you by the Teledyne LeCroy representative; be sure to add the following:
 - ATTN: <RMA assigned by the Teledyne LeCroy representative>
 - FRAGILE
7. Insure the item for the replacement cost of the probe.

8. If returning a probe to a different country, also:

- Mark shipments returned for service as a “Return of US manufactured goods for warranty repair/recalibration.”
- If there is a cost involved in the service, put the service cost in the value column and the replacement value of the probe in the body of the invoice marked “For insurance purposes only.”
- Be very specific as to the reason for shipment. Duties may have to be paid on the value of the service.

Available Accessories

Teledyne LeCroy Part Number	Description
PK033	Accessory Kit, AP033 without AC Coupler and Attenuator
AP03X-FLEX-LEAD	Flex Lead
405400003	Offset Pin, package of 10
AP033-ATTN	Plug-On Attenuator, /10, AP033
AP03X-AC-COUPLER	Plug-On AC Coupler, AP033/AP034
922260-00	Operator's Manual, AP033, English

Matching Procedure for ÷10 Plugs

The ÷10 Plug-on attenuator provided as a standard accessory with the AP033 is calibrated to match the specific probe it was shipped with. Individual probes will have small variations in parasitic capacitance within the input circuits. To obtain maximum common mode rejection performance, the attenuators are calibrated to match a specific probe during the manufacturing process. In order to preserve the maximum Common Mode Rejection, do not interchange external attenuators between probes.

The Plug-on AC coupling adapter is not matched to a specific probe and, therefore, does not need to be matched. If the ÷10 Plug-on attenuators become accidentally mixed between probes, you can use the procedure listed below to restore the compensation match. This adjustment does not affect any of the parameters in the warranted specifications. Therefore, the required test equipment does not need to be calibrated.

NOTE: The AP033 and AP033 Active Differential Probes have different input capacitance. The |10 Plug-on attenuator supplied with model AP033 cannot be properly adjusted for use with model AP033. Make sure that the attenuator is marked “AP033” before attempting this procedure.

Equipment Required

Test Oscilloscope

The oscilloscope must support ProBus. With a non-ProBus oscilloscope, use the ADPPS power supply.

Signal Source

Low frequency square wave: Frequency 50 Hz to 5 kHz, Amplitude 1 V to 10 V. The output waveform must have a square corner and flat top with minimum overshoot suitable for adjusting compensation. The generator should have trigger output, or use a BNC Tee connector and separate BNC cable from the output to provide the trigger signal for the test oscilloscope.

Interconnect Cable

This is for connecting the output of the signal source to the probe. A BNC cable and a pair of small alligator clips or “lead grabber” adapter (Pomona #3788) may be used. 0.025 in. (0.635 mm) Square Pins (3 required). The pins from the header supplied in the probe accessory kit are suitable.

Tools

Flat bladed screwdriver, 0.040 in. (1 mm) wide
Adjustment Tool: 0.025 in. (0.635 mm) square head

Note: You can fabricate the Adjustment Tool by flattening the end of a 0.025 in. (0.635 mm) square pin with a file. Insert the pin into a short length of rigid plastic tubing to serve as a handle.

Procedure

1. Attach the AP033 to the test oscilloscope. If the test oscilloscope is not equipped with ProBus, use the ADPPS to provide power for the AP033.
2. Attach the $\div 10$ Attenuator Adapter to the AP033 probe tip.
3. Insert 0.025 in. (0.635 mm) square pins into the +, -, and input connectors of the $\div 10$ Attenuator Adapter.
4. Attach the interconnect cable to the output of the signal source.
5. Attach the Trigger Out signal from the signal source to the External Trigger Input of the test oscilloscope. If the signal source does not have a separate Trigger Out signal, use a BNC Tee connector in the output. Run one cable to the External Trigger Input of the test oscilloscope. Connect the other to the probe inputs.
6. Using the alligator clips on the end of the interconnect cable, connect the signal source ground to the square pin on the $\div 10$ Attenuator Adapter's "-" input. Attach the signal output to the square pin on the $\div 10$ Attenuator Adapter's "+" input.
7. Turn on the test oscilloscope. Set the AP033 GAIN to X10. The EFFECTIVE GAIN indicator for $\div 10$ should be lit. (NOTE: If the X1 EFFECTIVE GAIN indicator is lit rather than the $\div 10$, make sure that the adapter installed on the probe tip is the $\div 10$ Attenuator, and not the AC Coupler.)
8. Set the test oscilloscope Volts/Div to 200 mV (for Teledyne LeCroy oscilloscopes with ProBus) or 20 mV/Div when using the ADPPS with an oscilloscope without scale factor correction; 5 μ s/Div; AUTO trigger mode; Trigger source: External. Set the Bandwidth Limiting to 20-30 MHz and Average the waveform 1:31 to reduce noise.
9. Turn on the signal source. Set the output frequency to approximately 5 kHz. Set the output amplitude to approximately 1 Volt.
10. Adjust the test oscilloscope trigger level for a stable trace. If necessary, use the probe offset to position the waveform to show the square corner of the test signal.

NOTE: Do not use the oscilloscope offset or position controls to reposition the trace. Many of the signal generators used for compensation calibration only have square corners on one of the two edges of the output waveform. (Rising or falling edge, but not both.) Be sure to display the correct edge for this step.

AP033 Active Differential Probe

- Using the square adjustment tool, adjust the +LF Comp (See Figure 6) to achieve the best square corner and flat top of the displayed waveform. Note that the added capacitance of the adjustment tool may change the compensation of the waveform when it is inserted. The correct adjustment is achieved when the best corner is displayed with the adjustment tool removed

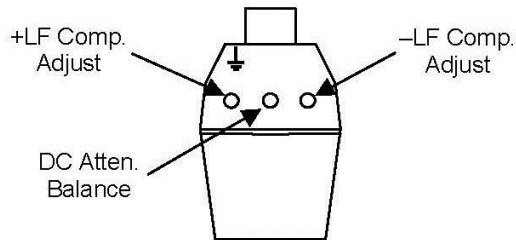

Figure 6, $\div 10$ Attenuator Adjustment Locations

- Move the connections on the interconnect cable so the signal generator ground is connected to the square pin inserted in the ground connector of the Attenuator Adapter. Connect the signal generator output to BOTH the + input and – input square pins in the Attenuator Adapter.
- Set the signal generator frequency to about 50 Hz, and the output amplitude to about 10 V.
- Set the test oscilloscope Volts/Div to 20 mV (for Teledyne LeCroy oscilloscopes with ProBus) or 2 mV/Div when using the ADPPS with an oscilloscope without scale factor correction; set the time scale to 2 ms/Div. It may be necessary to increase the averaging to 1:127 to remove noise.
- The displayed waveform is the common mode feedthrough. Using the adjustment screwdriver with the flat blade, adjust the DC Atten. Balance (Figure 6) to minimize the amplitude of the flat portions of the displayed waveform. This adjustment only affects the flat portions of the square wave. Do not be concerned with any overshoot at the transitions.
- Reduce the Test Oscilloscope Averaging weighting to 1:31. Return the Volts/Div to 200 mV (for Teledyne LeCroy oscilloscopes with ProBus) or 20 mV/Div when using the ADPPS with an oscilloscope without scale factor correction, and the Time/Div to 5 μ s.
- Return the signal source output frequency to approximately 5 kHz. Set the output amplitude to approximately 1 Volt.
- Using the 0.025 in. square adjustment tool, adjust the –LF Comp (Figure 6) to minimize the amplitude of overshoot during the transition of the displayed waveform. It may not be possible to completely eliminate the overshoot. As with the +LF Comp adjustment, the added capacitance of the adjustment tool may change the amplitude of the waveform when it is inserted into the adjustment. The correct adjustment is achieved when the overshoot is minimized.

Performance Verification

This procedure can be used to verify the warranted characteristics of the AP033 Active Differential Probe. You can do the performance verification without removing the instrument covers and exposing yourself to hazardous voltages.

Adjustment should only be attempted if a parameter measured in the Performance Verification Procedure is outside of the specified limits. Adjustment should only be performed by qualified personnel.

The recommended calibration interval for the model AP033 Active Differential Probe is one year. The complete performance verification procedure should be performed as the first step of annual calibration. You can record test results on a photocopy of the Test Record at the end of this section.

Test Equipment Required

Table 3 lists the test equipment and accessories (or their equivalents) that are required for performance verification of the AP033 Active Differential Probe.

This procedure has been developed to minimize the number of calibrated test instruments required. Only the parameters listed in **boldface** in the “Minimum Requirements” column must be calibrated to the accuracy indicated.

Because the input and output connector types may vary on different brands and models of test instruments, additional adapters or cables may be required.

AP033 Active Differential Probe

Table 3, Performance Verification Test Equipment

Description	Minimum Requirements	Example Test Equipment
Wide Band Oscilloscope (see note)	Minimum 1 GHz bandwidth 2 mV to 5 V scale factors ProBus interface equipped 2% vertical accuracy	Teledyne LeCroy Wavepro 950
Digital Multimeter	DC: 0.1% accuracy AC: 0.2% accuracy to measure 200 mV and 2 V rms @ 1 kHz 5½ digit resolution	Agilent Technologies 34401A Fluke 8842A-09 Keithley 2001
Function Generator	Sine Wave and Square Wave output waveforms 20 Vp-p into 1 MΩ 70 Hz to 10 MHz frequency range	Agilent Technologies 33120A Stanford Research Model DS340
Leveled Sine Wave Generator ²	Relative output level accurate to 3% flatness from 50 to 500 MHz and 50 kHz. Output adjustable to 2 Vp-p	Tegam SG504 with TM series mainframe A high frequency sine wave generator calibrated using semi-automated software leveled with a power meter may be substituted.
Terminator, in-line, BNC	50 Ω ±2% coaxial termination	Pomona 4119-50
Terminator, precision,	BNC 50 Ω ±0.2%	Teledyne LeCroy TERM-CF01
Attenuator, BNC	50 Ω ±2%, ±10 (20 dB)	Pomona 4108-20dB
Attenuator, BNC	50 Ω ± 2%, ±2 (6 dB),	Pomona 4108-6dB
BNC coaxial cable (2 required)	male-male BNC, 50 Ω, 36 in.	Pomona 5697-36
Calibration Fixture	ProBus Extension Cable	Teledyne LeCroy PROBUS-CF01
Calibration Fixture	AP033/AP034 Calibration Fixture	Teledyne LeCroy AP03x-CF01
Banana Plug adapter	BNC female-to-banana plug	Pomona 1269

NOTE: If a Teledyne LeCroy ProBus equipped oscilloscope is not available, you may use an alternate oscilloscope that meets the other minimum specifications listed, and the model ADPPS power supply, to perform the performance verification procedure. The input termination of the alternate oscilloscope must be set to 50 Ω and the offset or position must remain at center screen.

Preliminary Procedure

1. Connect the AP033 Active Differential Probe to the female end of the ProBus Extension Cable. Connect the male end of the ProBus extension cable to Channel 1 of the oscilloscope.
2. Turn the oscilloscope on and allow at least a 30- minutes warm-up time for the AP033 and test equipment before performing the Verification Procedure.
3. Turn on the other test equipment and allow these to warm up for the time recommended by the manufacturer.
4. While the instruments are reaching operating temperature, make a photocopy of the Performance Verification Test Record (located at the end of this section), and fill in the necessary information.

The warranted characteristics of the AP033 Active Differential Probe are valid at any temperature within the Environmental Characteristics listed in the Specifications. However, some of the other test equipment used to verify the performance may have environmental limitations required to meet the accuracy needed for the procedure. Make sure that the ambient conditions meet the requirements of all the test instruments used in this procedure.

Procedure

NOTE: The operation of the controls of the AP033 may differ depending on which version of firmware is loaded in the Teledyne LeCroy oscilloscope. In versions 8.1.0 and higher, the offset controls on the front panel of the probe are disabled. The AP033 offset is controlled by the **OFFSET** knob in the oscilloscope CHANNEL section. In software versions 7.6.0 to 8.0.x, probe offset is controlled through one of the menu knobs while the "Coupling" menu is displayed. In versions 7.8.0 and higher, you have the option of selecting manual or automatic gain control. The oscilloscope defaults to AUTOMATIC mode. This procedure is best performed with the oscilloscope set to MANUAL gain control. Gain control can be set via the "Coupling" menu or, for X-Stream oscilloscopes, the Channel dialog for the channel to which the probe is connected.

A. Check Gain Accuracy

1. From the oscilloscope display, select the channel that the AP033 is connected to (channel 1. Set the AP033 Atten/Gain to Manual, the Probe Gain to X1, and the Probe Atten to /1. (/1 is the same as $\div 1$)
2. If necessary, set the probe offset to 0.000 V by rotating the OFFSET knob in the CHANNEL section of the oscilloscope.

AP033 Active Differential Probe

- Using a BNC female-to-female adapter, connect one end of a BNC cable to the probe end of the ProBus Extension Cable. Connect the Precision 50 Ω Terminator to the other end of the BNC cable.
- Connect one end of a second BNC cable to the output of the Function Generator. Attach the BNC-to-dual-male banana plug adapter to the free end of the second BNC cable. Connect the banana plugs to the Digital Multimeter (DMM).
- Set the DMM to measure AC Volts.
- Set the mode of the Function Generator to Sine Wave; the frequency to approximately 1 kHz; and the output amplitude to approximately 200 mV rms, as measured by the DMM.
- Record the measured amplitude to 100 μ V resolution in the Test Record.
- Unplug the output cable from the DMM. Remove the BNC-to banana plug adapter from the end of the cable.
- Autobalance the AP033 by pressing the AUTOBALANCE menu button.
- Carefully align the four pins that correspond to the Differential Drive No Termination portion of the AP03x- CF01 Calibration Fixture with the input receptacles in the AP033 probe head. Press the probe into the fixture to fully engage the pins.
- Connect the banana plugs of the precision terminator to the digital multimeter (DMM)
- Connect the free end of the output cable from the Function Generator to the Differential Drive No Termination connector of the AP033/AP034 Calibration Fixture.
- After the DMM reading has stabilized, record the measured output amplitude to 100 μ V resolution in the Test Record.
- Divide the measured output voltage (recorded in step A-13) by the sine wave generator output voltage (probe input voltage) from step A-7. Subtract 1.0 from the ratio and multiply the result by 100 to get the error in percent.

$$\%Error = \left(\frac{\text{Measured Output Voltage}}{\text{Input Voltage}} - 1 \right) \times 100$$

- Record the answer to two significant places (\pm x.xx%) on line A-15 in the Test Record.
- Verify that the X1 gain error is less than \pm 2%.
- Change the Probe Atten to /10 and the Probe Gain to X10.

18. After the DMM reading has stabilized, record the measured output amplitude to 100 μ V resolution in the Test Record.
19. Divide the measured output voltage recorded in step A-18 by the sine wave generator output voltage (probe input voltage) from step A-7. Subtract 1.0 from the ratio and multiply the result by 100 to get the error in percent.

$$\%Error = \left(\frac{\text{Measured Output Voltage}}{\text{Input Voltage}} - 1 \right) \times 100$$

20. Record the answer to two significant places ($\pm x.xx\%$) on line A-20 in the Test Record.
21. Verify that the X10 gain error is less than $\pm 2\%$.
22. Divide the Sine Wave Generator output voltage recorded in step A-7 by 10. Record the result as "Expected Probe Output Voltage" in the Test Record.
23. Return the Probe Gain to X1. Leave the Probe Atten set to /10.
24. After the DMM reading has stabilized, record the measured output amplitude to 10 μ V resolution in the Test Record.
25. Calculate the error by dividing the measured output voltage recorded in step A-22. Subtract 1.0 from this ratio and multiply by 100 to get the error in percent.
26. Record the calculated error to two decimal places ($\pm x.xx\%$) as $\div 10$ Gain Error' in the Test Record.

$$\%Error = \left(\frac{\text{Measured Output Voltage}}{\text{Input Voltage}} - 1 \right) \times 100$$

27. Verify that the $\div 10$ gain error is less than $\pm 2\%$.
28. Disconnect both BNC cables from the test setup.

B. Check High Frequency Common Mode Rejection Ratio (CMRR)

NOTE: Common Mode Rejection Ratio (CMRR) is defined as the Differential Mode Gain divided by the Common Mode Gain (normalized inverse of the Common Mode response). At higher frequencies where the bandwidth of the amplifier begins to attenuate the differential mode signal, both the differential mode gain and common mode gain must be measured to derive the CMRR.

1. Disconnect the ProBus Extension cable from the AP033 and the oscilloscope. Reconnect the AP033 directly to the Channel 1 input of the oscilloscope.

AP033 Active Differential Probe

- Carefully move the AP033 probe head from the Differential Drive No Termination connector of the AP033/AP034 Calibration Fixture to the Differential Drive 50 Ohm Termination connector. Make sure that the probe is fully engaged in the fixture.
- Set the oscilloscope to display channel 1. Set Coupling to DC 1 M Ω , and Global BWL to Off. Autobalance the AP033 by pressing the AUTOBALANCE button twice. Set the oscilloscope trigger mode to AUTO.
- If necessary, center the trace with the Probe Offset (or Channel OFFSET) knob.
- Connect the output of the leveled sine wave generator to the Differential Drive 50 Ohm Termination connector of the AP033/AP034 Calibration Fixture. If using a model SG504 generator, insert a $\div 2$ 50 Ω BNC attenuator between the generator output and the test fixture input.
- Set the leveled sine wave generator frequency to 50 kHz, and the amplitude to approximately 300 mVp-p. When using a model SG504 generator, set the output to 0.6V pk-pk at the output which will correspond to 300 mV at the output of the $\div 2$ attenuator.
- Set the oscilloscope vertical scale factor to 50 mV/div and the horizontal scale factor to 10 μ sec/div. Set the Trigger source to Channel 1. Adjust the trigger level for a stable display. Turn on Math Channel A. Press MATH SETUP, then REDEFINE A. Set the A Math type to Average, Avg Type to Continuous, with 1:15 weighting, of channel 1. Turn off the trace 1 display.
- Adjust the output amplitude of the leveled sine wave generator for a display of exactly 6 divisions (300 mV) peak to peak.
- Change the leveled sine wave generator frequency to 250 MHz, taking care not to change the output amplitude.
- Change the oscilloscope horizontal scale to 1 ns/div. In the SETUP TIMEBASE menu, select RIS Sampling. If necessary, turn the channel 1 display back on and adjust the trigger for a stable trace. Once a stable trace has been achieved, turn off the channel 1 trace to only display the averaged waveform.
- Measure the peak-to-peak output amplitude of the AP033. Record the reading to two-digit resolution (xx0 mV) as 'Probe Output Voltage at 250 MHz' in the Test Record.
- Divide the measured output amplitude recorded in step B-11 by 300 mV. Record the answer to two-digit resolution (0.xx) in the Test Record. This is the 'Differential Mode Gain at 250 MHz'.
- Move the leveled sine wave generator output cable from the Differential Drive 50 Ohm Termination connector of the AP033/AP034 Calibration Fixture to the channel 2 input of the oscilloscope.

14. Carefully move the AP033 probe head from the Differential Drive 50 Ohm Termination connector of the AP033/AP034 Calibration Fixture to the Common Mode Drive 50 Ohm Termination connector. Make sure the probe is fully engaged in the fixture.
15. Set the oscilloscope to display channel 2, channel 2 vertical scale to 0.5 Volt/div, channel 2 input coupling to DC50Ω, and trigger source to channel 2. If necessary, adjust the trigger level for a stable display.
16. Set the sine wave generator output amplitude to exactly 2 V_{p-p}. (4 divisions on the oscilloscope).
17. Remove the leveled sine wave generator output cable from the oscilloscope and reconnect it to the Common Mode Drive 50 Ohm Termination input connector of the AP033/AP034 Calibration Fixture.
18. Set the oscilloscope to display Math channel A (Averaged AP033 Output), and trigger source to channel 1.
19. Increase the channel 1 vertical sensitivity as needed to view the signal.
20. Measure the peak to peak amplitude of the averaged waveform. This is the common mode signal.

NOTE: The amplitude of the Common Mode signal should be relatively small. If the output waveform appears to be a 1-Volt square wave, verify that the **Common Mode Drive 50 Ohm Termination** connector of the AP033/AP034 Calibration Fixture is being used, and not the **Differential Drive 50 Ohm Termination** connector.

21. Record the Common Mode signal amplitude to two-digit resolution (xx0 mV) in the Test Record as 'Common Mode Signal at 250 MHz'.
22. Calculate the Common Mode Gain by dividing the Common Mode signal recorded in step B-21 (in mV) by 2,000 mV.
23. Record the result to two significant places as 'Common Mode Gain at 250 MHz' in the Test Record. (Keep all of the leading zeros or use scientific notation.)
24. Calculate the Common Mode Rejection Ratio (CMRR) at 200 MHz by dividing the Differential Mode Gain at 250 MHz as recorded in step B-12 by the Common Mode Gain recorded in step B-23.
25. Record the result as 'Common Mode Rejection Ratio at 250 MHz' in the Test Record.
26. Verify that the CMRR at 250 MHz is greater than 5:1 (14 dB).
27. Disconnect the output and frequency reference cables from the leveled sine wave generator.

AP033 Active Differential Probe

C. Check Low Frequency CMRR

NOTE: The attenuation of the AP033 Active Differential Probe below 10 MHz is so insignificant that the Differential Mode Gain can be assumed to be unity (1.0). Because greater amplitudes are required to measure the higher CMRR specifications at low frequencies, the Function Generator will be used in place of the leveled sine wave generator for the low frequency CMRR test.

1. Carefully move the AP033 probe head from the Common Mode Drive 50 Ohm Termination connector of the AP033/AP033 Calibration Fixture to the Common Mode Drive No Termination connector. Make that sure the probe is fully engaged in the fixture.
2. Set the oscilloscope to display channel 2, the channel 2 input coupling to DC1 M Ω , the channel 2 vertical scale to 5 Volt/div, the horizontal scale to 5 ms/div, and the trigger source to channel 2. Set BW limiting on channels 1 and 2 to 25 MHz.
3. Verify the settings: Coupling to DC 1M Ω , Global BWL to Off, AP033 Attenuation/Gain to Manual, Probe Attenuation to /1, and Probe Gain to X1.
4. Attach a BNC cable from the output of the Function Generator to the BNC T adapter. Attach the BNC T adapter on the output connector of the Function Generator. Connect a BNC cable from one end of the BNC T adapter to channel 2 of the oscilloscope. Connect a second BNC cable from the remaining end of the BNC T adapter to the Common Mode Drive No Termination input connector of the AP033/AP034 Calibration Fixture.



CAUTION: Make sure that you use the Common Mode Drive No Termination connection. Prolonged application of the power levels used in the low frequency common mode test may damage the termination resistance in either 50 Ohm Termination input of the AP033/AP034 calibration fixture.

5. Set the sine wave generator frequency to 70 Hz, output amplitude to 8 Vp-p, (eight divisions on the oscilloscope). If necessary, adjust the trigger level for a stable display.
6. Set the oscilloscope to display channel 1, but leave the trigger source set to channel 2. Set the vertical scale of channel 1 to 2 mV/div. Create a math waveform on channel A defined as the Average of channel 1. Set the average factor as necessary to reduce noise. Turn off the waveform display of all channels except Math A waveform.
7. Increase the zoom of Math waveform A as needed to measure the peak-to-peak amplitude. This is the common mode signal.
8. Record the displayed 'Common Mode Signal at 70 Hz' to two-digit resolution (0.xx mV) in the Test Record.

9. Calculate the Common Mode Rejection Ratio (CMRR) at 70 Hz by dividing 8,000 mV by the measured Common Mode Signal recorded in step C-8 (direct reciprocal of the Common Mode Gain). Record the result to two-digit resolution (xx,000 : 1) in the Test Record.
10. Verify that the Common Mode Rejection Ratio at 70 Hz is greater than 3,160:1 (70 dB).
11. Set the oscilloscope to display channel 2. Change the horizontal scale factor to 0.5 s/division. Set the BWL on channels 1 and 2 to 200 MHz.
12. Change the frequency of the Function Generator to 1 MHz.
13. Adjust the trigger level as necessary for a stable display. Adjust the Function Generator amplitude as needed to maintain 8.0V pk-pk as measured on channel 2.
14. Turn off the oscilloscope channel 2 display; turn on the display of channel 1 and Math waveform A (averaged channel 1). Adjust the scale factor of channel 1 and the Zoom of Math A as necessary to accurately measure the amplitude of the averaged waveform.
15. Record the displayed 'Common Mode Signal at 1 MHz' to two-digit resolution in the Test Record.
16. Calculate the Common Mode Rejection Ratio (CMRR) at 1 MHz by dividing 8,000 mV by the measured Common Mode Signal recorded in step C-22. Record the result in the Test Record.
17. Verify that the Common Mode Rejection Ratio at 1 MHz is greater than 1,000:1 (60 dB).
18. Remove all cables and test fixtures from the AP033 probe.

This concludes the Performance Verification of the AP033. Complete and file the results recorded in the AP033 Performance Verification Test Record as required by your quality procedures. Apply a suitable calibration label to the AP033 housing as required.

AP033 Performance Verification Test Record

This record can be used to record the results of measurements made during the performance verification of the AP033 Active Differential Probe.

Photocopy the next page and record the results on the copy. File the completed record as required by applicable internal quality procedures.

The section in the test record corresponds to the parameters tested in the performance verification procedure. The numbers preceding the individual data records correspond to the steps in the procedure that require the recording of data. Results to be recorded in the column labeled "Test Result" are the actual specification limit check. The test limits are included in all of these steps. Other measurements and the results of intermediate calculations that support the limit check are to be recorded in the column labeled "Intermediate Results."

Permission is granted to reproduce these pages for the purpose of recording test results.

AP033 Active Differential Probe

Model: AP033
Serial Number: _____
Asset or Tracking Number: _____
Date: _____
Technician: _____

	MODEL	SERIAL NUMBER	CALIBRATION DUE DATE
OSCILLOSCOPE			
DIGITAL MULTIMETER			
LEVELED SINE WAVE GENERATOR			
HF SINE WAVE GENERATOR			
FUNCTION GENERATOR ¹			N/A

¹ The function generator provides stimulus for making relative measurements. The output amplitude of the generator is measured with the DMM or oscilloscope in the procedure. Thus, the generator is not required to be calibrated.

Step	Description	Intermediate Data	Test Result
Gain Accuracy			
A-7	Sine Wave Generator Output Voltage	_____ mV	
A-13	Probe Output Voltage	_____ mV	
A-15	Gain Error (Test Limit $\geq \pm 2\%$)		_____ %
High Frequency Common Mode Rejection Ratio (CMRR)			
B-13	Common Mode Signal at 100 MHz	_____ mV	
B-15	CMRR at 100 MHz (Test Limit $\geq 18:1$)		_____ :1
Low Frequency Common Mode Rejection Ratio			
C-7	Common Mode Signal at 70 Hz	_____ mV	
C-8	CMRR at 70 Hz (Test Limit $\geq 10\ 000:1$)		_____ :1
C-14	Common Mode Signal at 1 MHz	_____ mV	
C-15	CMRR at 1 MHz (Test Limit $\geq 100:1$)		_____ :1

Adjustment Procedure

Introduction

You can use this procedure to adjust the AP033 Active Differential Probe to meet the warranted specifications. This procedure should only be performed if the instrument fails the Performance Verification tests. If the probe cannot be adjusted to meet the Performance Verification limits, repair may be necessary. To ensure instrument accuracy, check the calibration of the AP033 Active Differential Probe every year. Before calibration, thoroughly clean and inspect this unit as discussed in the "Cleaning" section.

Completion of each step in the Adjustment Procedure ensures that the differential probe meets specifications. Some of the adjustments interact with other parts of the circuitry. Therefore, it is necessary that all adjustments be performed in the order listed. For best overall instrument performance, make each adjustment to the exact setting, even when adjustment is within the limits stated in the procedure.

Adequate guard bands were designed into the AP033 Active Differential Probe to ensure that it will meet or exceed published specifications over the entire operating temperature range. To continue to meet the environmental specifications, all adjustments must be performed in a controlled environment with an ambient temperature of 25 ± 5 °C. The AP033 Active Differential Probe must also be at stable operating temperature before performing adjustments.



CAUTION: The adjustment procedure will require removal of the probe covers. These covers are part of the ESD protection system of the AP033 Active Differential Probe. To protect the probe, you should perform the entire procedure on a static dissipating work surface. Wear an antistatic grounding wrist strap and follow standard static control procedures.

The probe tip housing provides physical rigidity to the input pins of the probe. When the covers are removed, observe extra caution to avoid breaking the probe tip receptacles when mating the probe to the calibration fixture.

Test Equipment Required

The table on the next page lists the test equipment and accessories, or their equivalents, that are required for complete calibration. Specifications given for the test equipment are the minimum necessary for accurate calibration. All test equipment is assumed to be correctly calibrated and operating within the specifications listed. Detailed operating instructions for the test equipment are not given in this procedure. Refer to the test equipment manual if more information is needed.

If alternate test equipment is substituted, control settings or calibration equipment setups may need to be altered. Alternate models of test equipment may have different connector styles requiring adapters not included in the equipment list.

Table 4, Adjustment Test Equipment

Description	Minimum Requirements	Example Test Equipment
Wide Band Oscilloscope *	500 MHz bandwidth 2 mV to 200 mV vertical scale factors ProBus interface equipped* 2% vertical accuracy	Teledyne LeCroy LT342 Teledyne LeCroy LC344A
Digital Multimeter	0.1% DC volts accuracy at 0.4 V 0.2% AC volts accuracy at 2 V and 1 kHz 5½ digit resolution 0.01 mV AC volts resolution	Agilent Technologies 34401A Fluke 8842A-09 Keithley 2001 with test leads
Function Generator	Sine and square wave output 20 Vp-p into 1 MΩ 50 Hz to 1 MHz frequency Range Sync. or Freq. Reference output	Agilent Technologies 33120A Stanford Research Model DS340 Leader LAG-120B
Fast Rise Pulse Generator	Risetime <2 ns Amplitude >400 mV into 50 Ω Over/Undershoot <6%	Calibrator signal from Teledyne LeCroy oscilloscope Tegam / Tektronix PG506 with power unit
Sine Wave Generator	Output 250 MHz at 1 V RMS	Agilent Technologies 8648C, with male N to female BNC adapter for the output connector. Tegam SG504 with TM series mainframe.
DC Voltage Source	0 to 2 VDC regulated output,	HP 6633A

Description	Minimum Requirements	Example Test Equipment
	settable to 1 mV resolution	
Termination, precision	50 Ω \pm 0.05%	Teledyne LeCroy TERM-CF01
Termination, BNC	50 Ω through male-female	Pomona 4119-50
Calibration Fixture	ProBus Extension Cable	Teledyne LeCroy PROBUS-CF01
Calibration Fixture	AP033/AP034 Calibration Fixture	Teledyne LeCroy AP03X-CF01
BNC coaxial cable (2 Required)	male-male BNC, approx. 1 m	Pomona 5697-36
BNC T Adapter	female-male-female	Pomona 3285
Banana Plug Adapter (2 Required)	BNC female to dual male banana plug	Pomona 1269
Shorting Plug	Two 0.025 in. square pins on 0.100 in. centers	Supplied with AP03X-CF01
Adjustment Tool	0.025 in. square tip	Johanson 4192
Low Capacitance Screwdriver		

NOTE: If a Teledyne LeCroy ProBus equipped oscilloscope is not available, you may perform the adjustment procedure with an alternate oscilloscope that meets the other Minimum Specifications, and the model ADPPS power supply. The input termination of the oscilloscope must be set at 50 Ω , the offset or position must remain at center screen, and the high-frequency adjustments must be performed with the ADPPS connected directly to the input of the oscilloscope.

Preliminary Procedure

1. Using pliers, carefully remove each of the push buttons from the ProBus interface housing by gently pulling them away from the housing.
2. Remove the two screws that secure the plastic cover on the cable end of the ProBus interface housing. Gently pull on the probe cable to slide the circuit board assembly from the metal housing.
3. Remove the 5/64 in. (2 mm) Allen head cap screw from the small cover on the back of the probe tip. Remove the cover along with the small cover on the opposite side of the probe. Hold the shielded portion of the probe head in one hand and gently slide the larger cover off by pulling it away from the probe tip end.
4. Connect the AP033 Active Differential Probe output to the female end of the ProBus Extension Cable. Be careful to align the ProBus pins with the corresponding connector correctly. Connect the male end of the ProBus Extension Cable to Channel 1 of the oscilloscope.

NOTE: The Logic board is connected to the Amplifier board by four small 8-pin connectors. There are no additional mechanical fasteners holding the two boards together. A small foam pad mounted on the circuit board ensures that the connectors remain engaged while the assembly is mounted within the ProBus interface housing. Be sure that the connectors between the boards are firmly engaged before applying power to the probe. Operating the probe without the logic board will not damage it. However, to ensure reliable operation, the logic board should only be mated with the Amplifier board with the power removed, and the ProBus connector disengaged.

5. Apply power to the oscilloscope and to the other test instrumentation. Allow at least 30 minute's warm-up time for the AP033 Active Differential Probe and test equipment before continuing the calibration procedure.

NOTE: The probe tip cover also serves to thermally stabilize the input circuitry. The differential input stage of the probe utilizes discrete transistors that need to maintain an approximate match of junction temperatures for correct DC balance. With the covers removed, this circuitry is susceptible to drift caused by air currents flowing over the components. Remove or redirect any fans that may be blowing air currents over the probe tip during adjustment.

Correct operation of the AP033 Active Differential Probe controls requires software version 8.1.0 or higher. You can find out the software version loaded on your Teledyne LeCroy scope by pressing SHOW STATUS, then selecting the System menu option. In version 8.1.0 and higher, the OFFSET controls on the probe are disabled. Offset is controlled by the OFFSET knob in the oscilloscope CHANNEL section.

Procedure

A. Adjust Preliminary Probe DC Balance (R36)

1. From the oscilloscope's front panel, select channel 1. Set the AP033 Atten/Gain to Manual, the Probe Atten to /10, and the Probe Gain to X10.
2. If necessary, set the probe offset to 0.000 V.
3. Connect one end of a BNC cable to the probe end of the ProBus Extension Cable. Attach the precision 50 Ω terminator to the opposite end of the BNC cable.
4. Insert the banana plugs of the precision 50 Ω terminator into the input terminals of the DMM.
5. Insert the two pin shorting plug into the socket on the Logic board. Use the two holes closest to the probe cable. (See Figure 6).

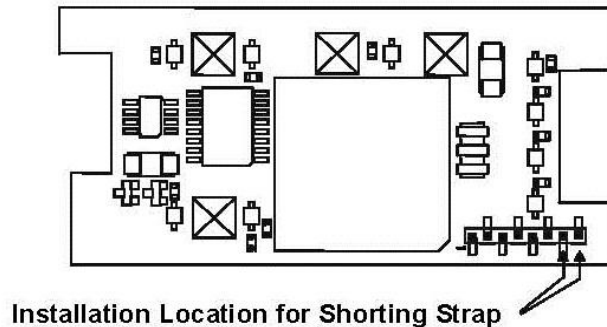

Figure 7, AP033 Logic Board

6. To enter the Cal Mode, push any one of the four buttons that protrude through holes in the Logic board. Entry into Cal Mode is confirmed by the absence of an audible "click" when you push the button.
7. Adjust DC Bal (R36) on the probe tip (Figure 7) to obtain a DMM reading of 0 V \pm 10 mV.

NOTE: This voltage may not be stable because of air currents near the probe. The average voltage should be 0 V \pm 10 mV.

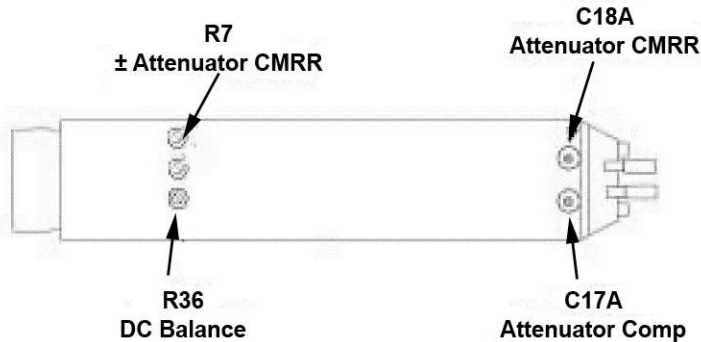

Figure 8, Probe Tip Adjustment Locations

B. Adjust Coarse DC Balance (R226)

1. Remove the shorting plug from the Logic Board.
2. Change the channel 1 Probe Gain to X1.
3. Reinsert the shorting plug into the two holes near the end of the Logic Board.
4. Reenter Cal Mode by pushing any one of the four buttons that protrude through holes in the Logic board.
5. Adjust Coarse DC Bal (R226) on the amplifier board for an output voltage of $0\text{ mV} \pm 10\text{ mV}$. (See Figure 9 for location.)

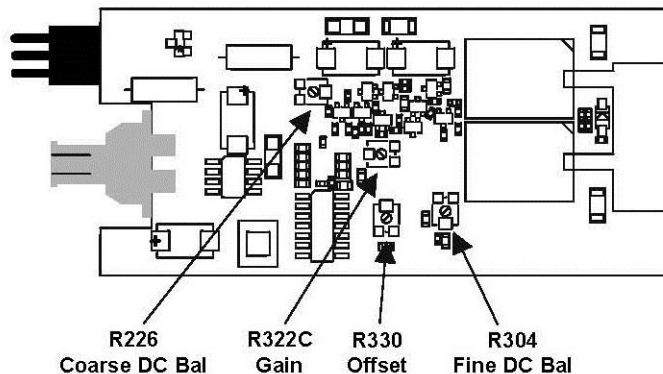

Figure 9, Amplifier Board Adjustment Locations

C. Adjust Fine DC Balance (R304)

1. Remove the shorting plug from the Logic Board.
2. In the Channel 1 "COUPLING" menu, change the Probe Gain to X10.
3. Reinsert the shorting plug into the two holes near the end of the Logic Board. (Figure 6.)
4. Reenter Cal Mode by pushing any one of the four buttons that protrude through holes in the Logic board.
5. Remove the BNC cable from the precision $50\ \Omega$ terminator attached to the DMM.
6. Short the output BNC connector by reconnecting the cable to the SHORT connector on the AP033/AP034 Calibration Fixture. The SHORT connector is the only BNC connector on the AP033/AP034 Calibration Fixture that does not have corresponding input pins for the probe tip. It is located on the end of the board beyond the Common Mode Terminated connector.
7. In Cal Mode, the EFFECTIVE GAIN indicators serve as an adjustment indicator. The EFFECTIVE GAIN indicators are located on the Logic Board (See Figure 10.) It may be necessary to hold the boards in your hands to see the indicators while making the adjustment.
8. Adjust Fine DC Balance (R304) until the ± 10 EFFECTIVE GAIN indicator lights.

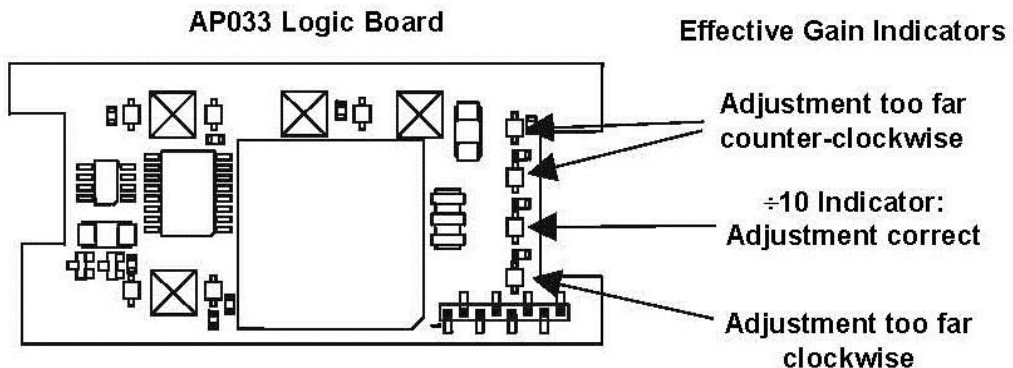

Figure 10, ± 10 Effective Gain Indicator

9. Disconnect the BNC cable from the short connector. Remove the shorting plug from the logic board.

D. Adjust $\div 10$ Attenuator CMRR (R7)

1. Keep the BNC cable attached to the probe end of the ProBus extension cable. Attach a 50 Ω BNC Through Terminator on the other end of the BNC cable. Attach the male end of the 50 Ω terminator to channel 3 on the oscilloscope. The oscilloscope end of the ProBus extension cable should remain connected to channel 1 of the oscilloscope although there is no signal cable attached.
2. In the Channel 1 "COUPLING" menu, set AP033 Atten/Gain to **Manual**, Probe Atten to **/10** and Probe Gain to **X10**.
3. Connect a BNC cable from the output of the Function Generator to the Channel 2 input of the oscilloscope.
4. Connect a second BNC cable from the Function Generator **SYNC OUT** to the external trigger input of the oscilloscope.
5. Set the Function Generator waveform to **Sine** and the frequency to 70 Hz.
6. Set the oscilloscope as follows:

Display: Channel 2
Channel 1 VOLTS/DIV: 2 mV/div
Channel 2 VOLTS/DIV: 5 V/div
Channel 3 VOLTS/DIV: 2 mV/div
Channel 2 Coupling: DC1M Ω
Channel 3 Coupling: AC 1M Ω
Trigger on: EXT10
cplg EXT10: DC
TIME/DIV: 10 ms/div
Acquisition Mode: NORMAL

7. Adjust the trigger level for a stable display.
8. Set the Function Generator output voltage to 20 Vp-p as displayed on the oscilloscope.
9. Disconnect the output cable of the function generator from the channel 2 input of the oscilloscope and reconnect it to the Common Mode Drive No Termination connector of the AP033/AP034 Calibration Fixture.
10. Carefully align the four pins that correspond to the Common Mode Drive No Termination portion of the AP033/AP034 Calibration Fixture with the input receptacles in the AP033 probe head. Press the probe into the fixture to fully engage the pins.
11. Set the oscilloscope to display channel 3. The waveform is the common mode signal. Turn the offset as necessary to keep the trace on screen. Turn on Math Channel A. Press MATH SETUP, then REDEFINE A. Set the A Math type to Average, Avg Type to Continuous, with 1:15

weighting, of channel 3. Turn off the trace 3 display. Use the Math Zoom and Position controls as necessary to view the waveform.

12. Adjust $\div \square \square$ CMRR (R7) for minimum amplitude. (See Figure 10 for location.)
13. Remove the BNC cable from the output of the Function Generator and the calibration fixture. Leave the BNC cable from the SYNC output to the oscilloscope external trigger input in place. Remove the BNC cable and 50 Ω terminator from channel 3.

E. Adjust OFFSET (R330)

1. In the oscilloscope channel 1 "COUPLING" menu, set AP033 Atten/Gain to Manual, Probe Atten to /1 and Probe Gain to X1. Set the channel 1 scale factor to 2 mV/div, and the acquisition mode to Auto. Set the BWL to 20 or 25 MHz. Adjust the OFFSET to 0.0 mV.
2. Carefully move the AP033 probe tip from the Common Mode Drive No Termination position of the AP033/AP034 Calibration Fixture to the Differential Drive No Termination position. Press the probe into the fixture to fully engage the pins.
3. Attach the female BNC to dual male banana plug adapters to each end of the BNC cable. Plug one end into the output of the DC voltage source, making sure that the plug corresponding to the BNC shield (marked "Ground") is connected to the voltage source – output (or common for dual supplies) connector, and the other pin on the + output connector.
4. Connect the other end of the cable to the DMM input, making sure that the plug corresponding to the BNC shield (marked "Ground") is connected to the LO or COM input.
5. Set the DC Voltage Source to read as close as possible to +0.4000 V on the DMM.
6. Autobalance the AP033 by pressing the AUTOBALANCE button twice, or by pressing and holding both probe offset buttons for at least two seconds.
7. Disconnect the BNC cable from the female BNC-to-dual male banana plug adapter on the DMM.
8. Reconnect the BNC cable from the DC Voltage Source to the Differential Drive No Termination connector on the AP033/AP034 Calibration Fixture.
9. Set the probe offset to –0.4000 V by rotating the OFFSET knob in the CHANNEL section of the oscilloscope (or with the OFFSET knob linked to the "COUPLING" menu when using the older software.)
10. Allow 10 seconds for the AP033 to stabilize.
11. Adjust Offset (R330) to bring the trace back to exactly center screen. (See Figure 11.)
12. Remove the dual banana plug adapter from the output of the DC voltage source and reconnect it, with the pins reversed. (The plug corresponding to the BNC shield (marked "Ground") should now be connected to the + **Output** connector.)

AP033 Active Differential Probe

13. In the CHANNEL section of the oscilloscope, set the probe offset to +0.4000 V by rotating the OFFSET knob (or with the OFFSET knob linked to the COUPLING menu when using the older software.)
14. Allow 10 seconds for the AP033 to stabilize.
15. Note the amplitude of the trace from center screen.
16. Adjust Offset Cal (R330) to position the trace to approximately $\frac{1}{2}$ the amplitude from center screen noted in the previous step. This amplitude should be within 10 mV of center screen. Note this value.
17. Again, remove the dual banana plug adapter from the output of the DC voltage source and reconnect it, with the pins reversed. The plug corresponding to the BNC shield (marked "Ground") should now be connected to the – (Common) Output connector.
18. Set the probe offset to –0.4000 V.
19. Allow 10 seconds for the AP033 to stabilize.
20. The trace should be offset from the center line by the same amplitude but opposite polarity of the value noted in step 16.
21. Repeat steps E-12 through E-20 as necessary until the errors at +0.4 V and at –0.4 V are approximately equal and within 10 mV of center scale. Reverse the polarity of the dual banana plug adapter at the output of the DC voltage source, and the corresponding probe offset value with each repetition.
22. Disconnect the cable from the DC Voltage Source. Keep the AP033/AP034 Calibration Fixture connected to the AP033 for the next step.

F. Adjust GAIN (R322C)

1. Set the AP033 offset to 0.000 V by rotating the OFFSET knob in the CHANNEL section of the oscilloscope (or with the OFFSET knob linked to the "COUPLING" menu when using the older software versions). Make sure the probe is still set to /1 Atten and X1 Gain.
2. Disconnect the BNC cable from the oscilloscope end of the ProBus extender cable. Reconnect the end of the cable to the precision 50 Ω termination.
3. Connect one end of a second BNC cable to the output of the Function Generator. Attach the BNC to dual male banana plug adapter to the free end of the BNC cable. Insert the banana plugs of the adapter into the input terminals of the Digital Multimeter (DMM).
4. Set the DMM to measure AC Volts.
5. Set the mode of the Function Generator to Sine Wave, the frequency to approximately 1 kHz, and the output amplitude to read approximately 190 mV on the DMM.

6. Record the DMM reading. Be careful not to alter the output amplitude of the generator after the measured value has been recorded.
7. Remove the banana plug adapter and connect the free end of the cable to the Differential Drive no Termination connector on the calibration fixture.
8. Connect the AP033 Output cable with 50 Ω precision termination to the DMM.
9. Adjust GAIN (R322C) so that the DMM reading is within ± 1 mV (0.5%) of the reading recorded in step F-6. (See Figure 11.)
10. Set AP033 Attenuation/Gain to Manual, Probe Gain to X10, and Probe Atten to /10.
11. Verify that the DMM reads within 1 mV of the reading recorded in step F-6. If the error exceeds 1 mV, readjust GAIN (R322C) for an error amplitude of $\frac{1}{2}$ of the value before making the readjustment. Compromise as necessary to center the error voltage in both gain/attenuation combinations, making sure that the final errors are less than 1 mV.
12. Disconnect the Function Generator, DMM, calibration fixture, and precision 50 Ω terminator.

G. Adjust Final Attenuator Compensation (C17)

NOTE: The calibrator signal from a Teledyne LeCroy oscilloscope is the recommended signal source for this adjustment. If another oscilloscope is being used for this procedure, make sure that the square wave source has adequate flatness (minimum overshoot and undershoot.)

1. Press the UTILITIES button, then select the CAL BNC Setup menu. Set the Mode to CAL signal, the Shape to Square, the Amplitude to 1 V into 1 M Ω , and the Frequency to 1 kHz.
2. On the Channel 1, set AP033 Attenuation/Gain to Manual, Probe Attenuation to /10, and Probe Gain to X10.
3. Reconnect the free end of the ProBus Extender BNC cable to the oscilloscope end of the extender located on channel 1.
4. Connect a BNC cable from the CAL output BNC connector to the Differential Drive 50 Ohm Termination connector on the AP033/AP034 Calibration Fixture.
5. Carefully attach the Differential Drive 50 Ohm Termination portion of the AP033/AP034 Calibration Fixture to the probe tip. Press the probe into the fixture to fully engage the pins.
6. Set the oscilloscope's channel 1 vertical scale factor to 50 mV/div, and the horizontal scale to 1 μ s/div. Set the trigger source to channel 1, and Slope to Positive. Adjust the oscilloscope trigger level as necessary for a stable display.
7. Using the OFFSET knob move the trace down until the top portion of the waveform is centered.
8. Adjust Attenuator Comp (C17A) for a flattop waveform. See Figure 10 for adjustment location.

H. Adjust Final Attenuator CMRR (C18A)

1. Carefully move the AP033 probe head from the Differential Drive 50 Ohm Termination portion of the AP033/AP034 Calibration Fixture to the Common Mode Drive 50 Ohm Termination portion.
2. Remove the BNC cable from the Differential Drive 50 Ohm Termination connector of the AP033/AP034 Calibration Fixture. Connect one end of the BNC cable to the Common Mode Drive 50 Ohm Termination connector of the AP033/AP034 Calibration fixture. Connect the other end of the cable to the female end of a BNC T adapter. Plug the male connector of the BNC T adapter into the channel 4 input of the oscilloscope. Connect a second BNC cable to the remaining female connector of the BNC T adapter. Connect the other end of the second BNC cable to the CAL output BNC connector.
3. Set the oscilloscope to display channel 4, coupling to DC1M Ω vertical scale factor to 200 mV/div and the trigger source to channel 4. Adjust the oscilloscope trigger level as necessary for a stable display.
4. Set the oscilloscope to display channel 1, vertical scale factor to 10 mV/div. Set the OFFSET to 0.0 mV
5. Adjust Attenuator CMRR (capacitor C18A) for minimum amplitude shift of the displayed waveform at the trigger point in time. See Figure 10 for adjustment location.
6. Remove all cables, the Calibration Fixture, and the ProBus extender from the AP033 probe.

I. Assemble Probe and Amplifier

1. Carefully slide the large probe tip cover over the probe tip, being careful to engage the input pins.
2. Snap the small probe cover with the threaded brass insert onto the bottom of the probe. Engage the probe cable strain relief into the mating area of the cover. Carefully dress the wires entering the cable to clear the area above the brass insert.
3. Place the lip on the large end of the remaining cover under the mating surface near the probe tip. Gently press the cover into place. If the cover appears to not close completely, remove it and again check for adequate clearance between the brass insert and the cable wires.
4. Replace the 5/64" Allen cap screw and tighten.
5. Hold the Logic Board / Amplifier Board assembly in one hand with the Logic board facing up. Hold the ProBus Interface housing in the other hand with the control side (side with holes for the buttons) facing up.
6. Align the edges of the Amplifier board with the slots in the center of the inside of the housing. (The amplifier board is the thicker circuit board and has the BNC connector soldered to it.) Slide

the boards into the housing being careful to align the screw holes in the end cover with the corresponding channels in the corners of the housing.

7. Insert and tighten the two screws which secure the end panel to the ProBus interface housing. Avoid over tightening the screws as the cover may warp.
8. Replace the four push button caps, pressing each fully to seat the cap on the button shaft.

J. Attenuator Matching and Final Check

1. Repeat the Performance Verification procedure to ensure compliance with the warranted specifications.
2. Perform the Attenuator Matching Procedure listed on page 22. Apply calibration seals in accordance with your quality procedures.

This concludes the Adjustment Procedure. Repeat the Performance Verification procedure to complete the calibration of the AP033.

Reference Information

Differential Mode and Common Mode

Differential probes amplify the voltage difference that appears between the + and – inputs. This voltage is referred to as the Differential Mode or Normal Mode voltage. The voltage component that is referenced to earth ground, and is identical on both inputs, is rejected by the amplifier. This voltage is referred to as the Common Mode voltage, because it is common to both inputs. The common mode voltage can be expressed as:

$$V_{CM} = \frac{V_{+Input} + V_{-Input}}{2}$$

Differential Mode Range and Common Mode Range

The Differential Mode Range is the maximum signal that can be applied between the + and – inputs without overloading the probe amplifier, resulting in “clipping” or distortion of the waveform measured by the oscilloscope.

The Common Mode Range is the maximum voltage with respect to earth ground that can be applied to either input. Exceeding the common mode range can result in unpredictable results. Because the Common Mode signal is normally rejected and is not displayed on the oscilloscope, you need to be careful to avoid accidentally exceeding the common mode range.

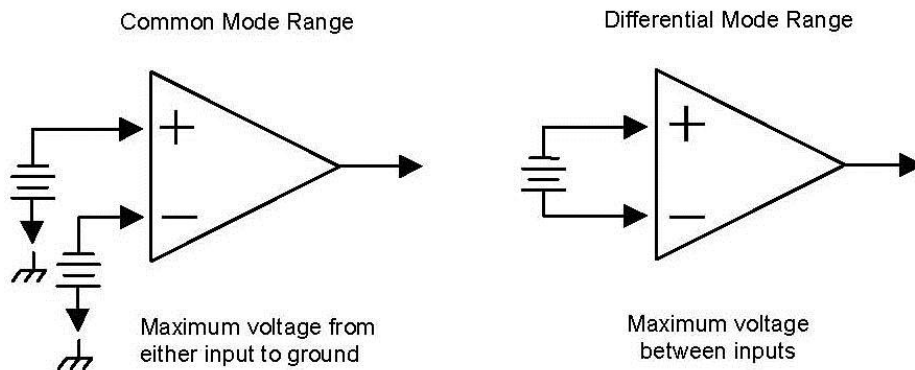

Figure 11, Common Mode and Differential Mode Range

Common Mode Rejection Ratio

The ideal differential probe or differential amplifier would amplify only the differential mode voltage component and reject all of the common mode voltage component. Real differential probes and amplifiers are less than ideal, so a small portion of the common mode voltage component appears in the output. Common Mode Rejection Ratio (CMRR) is the measure of how effectively the probe or amplifier rejects the common mode voltage component. CMRR is equal to the differential mode gain (or normal gain) divided by the common mode gain. Common mode gain is equal to the output voltage divided by the input voltage when both inputs are driven by only the common mode signal. CMRR can be expressed as a ratio (for example, 10,000:1) or implicitly in dB (for example, 80 dB). Higher numbers indicate greater rejection (better performance).

The first order term that determines the CMRR is the relative gain matching between the + and - input paths. To obtain high CMRR values, the input attenuators in a differential probe are precisely matched to each other. The matching includes the DC attenuation as well as the capacitance that determines the AC attenuation. As the frequency of the common mode components increases, the effects of stray parasitic capacitance and inductance in determining the AC attenuation become more pronounced. The CMRR becomes smaller as the frequency increases. Hence, CMRR is usually specified as a plot versus common mode frequency.

The common mode frequency in these plots is assumed to be sinusoidal. In real life applications, the common mode signal is seldom a pure sine wave. Signals with pulse wave shapes contain frequency components much higher than the repetition rate may suggest. As such, it is very difficult to predict actual performance in the application for CMRR versus frequency graphs. The practical application of these graphs is to compare the relative common mode rejection performance between different probes or amplifiers.

Certifications

This section certifies the probe's Electromagnetic Compatibility (EMC), Safety and Environmental compliance.

EMC Compliance

EC DECLARATION OF CONFORMITY - EMC

The probe meets intent of EC Directive 2004/108/EC for Electromagnetic Compatibility. Compliance was demonstrated to the following specifications as listed in the Official Journal of the European Communities:

EN 61326-1:2006, EN 61326-2-1:2006 EMC requirements for electrical equipment for measurement, control, and laboratory use.

Electromagnetic Emissions:

CISPR 11:2003, Radiated and Conducted Emissions Group 1, Class A ^{1 2}

Electromagnetic Immunity:

EN 61000-4-2:2001 Electrostatic Discharge, 4 kV contact, 8 kV air, 4 kV vertical/horizontal coupling planes ³

EN 61000-4-3:2006 RF Radiated Electromagnetic Field, 3 V/m, 80-1000 MHz; 3 V/m, 1400 MHz - 2 GHz; 1 V/m, 2 GHz - 2.7 GHz ³

1 Emissions which exceed the levels required by this standard may occur when the probe is connected to a test object.

2 This product is intended for use in nonresidential areas only. Use in residential areas may cause electromagnetic interference.

3 Meets Performance Criteria "B" limits of the respective standard: during the disturbance, product undergoes a temporary degradation or loss of function or performance which is self-recoverable.

European Contact:

Teledyne LeCroy Europe GmbH
Waldhofer Str 104
D-69123 Heidelberg
Germany
Tel: (49) 6221 82700

AUSTRALIA & NEW ZEALAND DECLARATION OF CONFORMITY—EMC

The probe complies with the EMC provision of the Radio Communications Act per the following standards, in accordance with requirements imposed by Australian Communication and Media Authority (ACMA):

CISPR 11:2003 Radiated and Conducted Emissions, Group 1, Class A, in accordance with EN61326-1:2006 and EN61326-2-1:2006.

Australia / New Zealand Contacts:

Vicom Australia Ltd.
1064 Centre Road
Oakleigh, South Victoria 3167
Australia

Vicom New Zealand Ltd.
60 Grafton Road
Auckland
New Zealand

Safety Compliance

EC DECLARATION OF CONFORMITY – LOW VOLTAGE

The probe meets intent of EC Directive 2006/95/EC for Product Safety. Compliance was demonstrated to the following specifications as listed in the Official Journal of the European Communities:

EN 61010-1:2010 Safety requirements for electrical equipment for measurement, control, and laboratory use – Part 1: General requirements

EN 61010-2:030:2010 Safety requirements for electrical equipment for measurement, control, and laboratory use – Part 2-030: Particular requirements for testing and measuring circuits

EN 61010-031/A1:2008 Safety requirements for electrical equipment for measurement, control, and laboratory use – Part 031: Safety requirements for hand-held probe assemblies for electrical measurement and test.

Environmental Compliance

END-OF-LIFE HANDLING



The probe is marked with this symbol to indicate that it complies with the applicable European Union requirements to Directives 2002/96/EC and 2006/66/EC on Waste Electrical and Electronic Equipment (WEEE) and Batteries.

The probe is subject to disposal and recycling regulations that vary by country and region. Many countries prohibit the disposal of waste electronic equipment in standard waste receptacles. For more information about proper disposal and recycling of your Teledyne LeCroy product, please visit teledynelecroy.com/recycle.

RESTRICTION OF HAZARDOUS SUBSTANCES (RoHS)

The probe has been classified as Industrial Monitoring and Control Equipment, and is outside the scope of the 2011/65/EU RoHS Directive (Exempt until July 2017, per Article 4).

ISO Certification

Manufactured under an ISO 9000 Registered Quality Management System. Visit teledynelecroy.com to view the certificate.

Contact Teledyne LeCroy

Teledyne LeCroy Service Centers	
<p>United States and Canada - World Wide Corporate Office Teledyne LeCroy Corporation 700 Chestnut Ridge Road Chestnut Ridge, NY, 10977-6499, USA Ph: 800-553-2769 / 845-425-2000 FAX: 845-578-5985 teledynelecroy.com Support: contact.corp@teledynelecroy.com Sales: customersupport@teledynelecroy.com</p>	<p>United States - Protocol Solutions Group Teledyne LeCroy Corporation 3385 Scott Boulevard Santa Clara, CA, 95054, USA FAX: 408-727-0800 teledynelecroy.com Sales and Service: Ph: 800-909-7211 / 408-727-6600 contact.corp@teledynelecroy.com Support: Ph: 800-909-7112 / 408-653-1260 psgsupport@teledynelecroy.com</p>
<p>European Headquarters Teledyne LeCroy SA 4, Rue Moïse Marcinhes Case postale 341 1217 Meyrin 1 Geneva, Switzerland Ph: + 41 22 719 2228 / 2323 /2277 FAX:+41 22 719 2233 contact.sa@teledynelecroy.com applications.indirect@teledynelecroy.com teledynelecroy.com/europe Protocol Analyzers: Ph: +44 12 765 03971</p>	<p>Singapore, Oscilloscopes Teledyne LeCroy Singapore Pte Ltd. Blk 750C Chai Chee Road #02-08 Technopark @ Chai Chee Singapore 469003 Ph: ++ 65 64424880 FAX: ++ 65 64427811 Singapore, Protocol Analyzers Genetron Singapore Pte Ltd. 37 Kallang Pudding Road, #08-08 Tong Lee Building Block B Singapore 349315 Ph: ++ 65 9760-4682</p>
<p>China Teledyne LeCroy Corporation Beijing Rm. 2001 - Office; Rm. 2002 - Service Center Unit A, Horizon Plaza No. 6, Zhichun Road, Haidian District Beijing 100088, China Ph: ++86 10 8280 0318 / 0319 / 0320 FAX:++86 10 8280 0316 Service: Rm. 2002 Ph: ++86 10 8280 0245</p>	<p>Korea Teledyne LeCroy Korea 10th fl.Ildong Bldg. 968-5 Daechi-dong, Gangnam-gu Seoul 135-280, Korea Ph: ++ 82 2 3452 0400 FAX: ++ 82 2 3452 0490</p>
<p>Taiwan LeColn Technology Co Ltd. Far East Century Park, C3, 9F No. 2, Chien-8th Road, Chung-Ho Dist., New Taipei City, Taiwan Ph: ++ 886 2 8226 1366 FAX: ++ 886 2 8226 1368</p>	<p>Japan Teledyne LeCroy Japan Hobunsya Funchu Bldg, 3F 3-11-5, Midori-cho, Fuchu-Shi Tokyo 183-0006, Japan Ph: ++ 81 4 2402 9400 FAX: ++ 81 4 2402 9586 teledynelecroy.com/japan</p>



700 Chestnut Ridge Road
Chestnut Ridge, NY 10977
USA

teledynelecroy.com

Компания «Life Electronics» занимается поставками электронных компонентов импортного и отечественного производства от производителей и со складов крупных дистрибьюторов Европы, Америки и Азии.

С конца 2013 года компания активно расширяет линейку поставок компонентов по направлению коаксиальный кабель, кварцевые генераторы и конденсаторы (керамические, пленочные, электролитические), за счёт заключения дистрибьюторских договоров

Мы предлагаем:

- Конкуренспособные цены и скидки постоянным клиентам.
- Специальные условия для постоянных клиентов.
- Подбор аналогов.
- Поставку компонентов в любых объемах, удовлетворяющих вашим потребностям.
- Приемлемые сроки поставки, возможна ускоренная поставка.
- Доставку товара в любую точку России и стран СНГ.
- Комплексную поставку.
- Работу по проектам и поставку образцов.
- Формирование склада под заказчика.
- Сертификаты соответствия на поставляемую продукцию (по желанию клиента).
- Тестирование поставляемой продукции.
- Поставку компонентов, требующих военную и космическую приемку.
- Входной контроль качества.
- Наличие сертификата ISO.

В составе нашей компании организован Конструкторский отдел, призванный помогать разработчикам, и инженерам.

Конструкторский отдел помогает осуществить:

- Регистрацию проекта у производителя компонентов.
- Техническую поддержку проекта.
- Защиту от снятия компонента с производства.
- Оценку стоимости проекта по компонентам.
- Изготовление тестовой платы монтаж и пусконаладочные работы.



Тел: +7 (812) 336 43 04 (многоканальный)

Email: org@lifeelectronics.ru