

Signal conditioner - MINI MCR-2-UI-UI - 2902037

Please be informed that the data shown in this PDF Document is generated from our Online Catalog. Please find the complete data in the user's documentation. Our General Terms of Use for Downloads are valid (<http://phoenixcontact.com/download>)



3-way signal conditioner with plug-in connection technology and calibrated measuring range changeover for the electrical isolation of unipolar and bipolar analog signals. Input/output configurable via DIP switch. Screw connection technology, standard configuration.

Figure shows MINI MCR-2-UI-UI-PT version

Product description

The 3-way signal conditioner with plug-in connection technology and calibrated measuring range changeover can be configured using DIP switches and is used for the electrical isolation, conversion, amplification, and filtering of unipolar and bipolar standard and normalized signals. On the input side, the standard analog signals 0 ... 20 mA, 4 ... 20 mA, 0 ... 10 V, 0 ... 5 V, 1 ... 5 V or 10 ... 10 V, and signals 2 ... 10 V, 0 ... 20 V, 4 V ... 20 V, 0 ... 24 V, 0 ... 30 V, -5 ... 5 V, -20 ... 20 V, -24 ... 24 V, -30 ... 30 V, and -20 ... 20 mA are available. On the output side, 0 ... 20 mA, 4 ... 20 mA, 0 ... 10 V, 0 ... 5 V, 1 ... 5 V, -10 ... 10 V, and -5 ... 5 V are possible. There is no need for adjustment following a measuring range changeover. The measuring transducer supports fault monitoring and NFC communication.



Key commercial data

Packing unit	1 pc
Weight per Piece (excluding packing)	100.0 GRM
Custom tariff number	85437090
Country of origin	Germany

Technical data

Note

Utilization restriction	EMC: class A product, see manufacturer's declaration in the download area
-------------------------	---

Dimensions

Width	6.2 mm
Height	110.5 mm
Depth	120.5 mm

Signal conditioner - MINI MCR-2-UI-UI - 2902037

Technical data

Ambient conditions

Ambient temperature (operation)	-40 °C ... 70 °C
Ambient temperature (storage/transport)	-40 °C ... 85 °C
Degree of protection	IP20

Input data

Number of inputs	1
Configurable/programmable	Yes
Voltage input signal	0 V ... 5 V (via DIP switch)
	1 V ... 5 V (via DIP switch)
	-5 V ... 5 V (via DIP switch)
	0 V ... 10 V (via DIP switch)
	2 V ... 10 V (via DIP switch)
	-10 V ... 10 V (via DIP switch)
	0 V ... 20 V (via DIP switch)
	4 V ... 20 V (via DIP switch)
	-20 V ... 20 V (via DIP switch)
	0 V ... 24 V (via DIP switch)
	4.8 V ... 24 V (via DIP switch)
	-24 V ... 24 V (via DIP switch)
	0 V ... 30 V (via DIP switch)
	6 V ... 30 V (via DIP switch)
	-30 V ... 30 V (via DIP switch)
Current input signal	0 mA ... 20 mA (via DIP switch)
	4 mA ... 20 mA (via DIP switch)
	-20 mA ... 20 mA (via DIP switch)
Max. input voltage	33 V
Max. input current	24 mA
Input resistance of voltage input	> 1000 kΩ
Input resistance current input	approx. 63 Ω

Output data

Number of inputs	1
Configurable/programmable	Yes
Voltage output signal	0 V ... 5 V (via DIP switch)
	1 V ... 5 V (via DIP switch)
	-5 V ... 5 V (via DIP switch)
	0 V ... 10 V (via DIP switch)
	2 V ... 10 V (via DIP switch)

Signal conditioner - MINI MCR-2-UI-UI - 2902037

Technical data

Output data

	-10 V ... 10 V (via DIP switch)
Current output signal	0 mA ... 20 mA (via DIP switch)
	4 mA ... 20 mA (via DIP switch)
Max. output current	22 mA
Short-circuit current	< 32 mA
Load/output load voltage output	≥ 10 kΩ
Load/output load current output	≤ 600 Ω (at 20 mA)

Power supply

Nominal supply voltage	24 V DC
Supply voltage range	9.6 V DC ... 30 V DC (The DIN rail bus connector (ME 6,2 TBUS-2 1,5/5-ST-3,81 GN, Order No. 2869728) can be used to bridge the supply voltage. It can be snapped onto a 35 mm DIN rail according to EN 60715))
Typical current consumption	25 mA (Current output, at 24 V DC incl. load)
	54 mA (Current output, at 12 V DC incl. load)
Power consumption	≤ 800 mW (at I _{OUT} = 20 mA, 9.6 V DC, 600 Ω load)

Connection data

Connection method	Screw connection
Single conductor/terminal point, solid, with ferrule, min.	0.2 mm ²
Single conductor/terminal point, solid, with ferrule, max.	1.5 mm ²
Single conductor/terminal point, solid, without ferrule, min.	0.2 mm ²
Single conductor/terminal point, solid, without ferrule, max.	2.5 mm ²
Conductor cross section flexible min.	0.2 mm ²
Conductor cross section flexible max.	1.5 mm ²
Min. AWG conductor cross section, flexible	24
Max. AWG conductor cross section, flexible	12
Stripping length	10 mm
Screw thread	M3

General

Maximum transmission error	≤ 0.1 % (of final value)
Maximum temperature coefficient	0.01 %/K
Limit frequency (3 dB)	30 Hz (via DIP switch)
	5 kHz (via DIP switch)
Step response (10-90%)	< 8.5 ms (with 30 Hz filter)
Protective circuit	Transient protection
Electrical isolation	Reinforced insulation in accordance with IEC 61010-1
Surge voltage category	II

Signal conditioner - MINI MCR-2-UI-UI - 2902037

Technical data

General

Pollution degree	2
Rated insulation voltage	300 V
Test voltage, input/output/supply	3 kV (50 Hz, 1 min.)
Electromagnetic compatibility	Conformance with EMC Directive 2004/108/EC
Noise emission	EN 61000-6-4
Noise immunity	EN 61000-6-2 When being exposed to interference, there may be minimal deviations.
Color	gray
Housing material	PBT
Mounting position	any
Assembly instructions	The T connector can be used to bridge the supply voltage. It can be snapped onto a 35 mm DIN rail according to EN 60715.
Conformance	CE-compliant
ATEX	# II 3 G Ex nA IIC T4 Gc X
UL, USA / Canada	UL 508 Listed
	Class I, Div. 2, Groups A, B, C, D T6
	Class I, Zone 2, Group IIC T6

EMC data

Designation	Electromagnetic RF field
Standards/regulations	EN 61000-4-3
Designation	Fast transients (burst)
Standards/regulations	EN 61000-4-4
Designation	Conducted interferences
Standards/regulations	EN 61000-4-6

Classifications

eCl@ss

eCl@ss 4.0	27040702
eCl@ss 4.1	27040702
eCl@ss 5.0	27242213
eCl@ss 5.1	27049002
eCl@ss 6.0	27049002
eCl@ss 7.0	27049002
eCl@ss 8.0	27210120

ETIM

ETIM 3.0	EC001039
----------	----------

Signal conditioner - MINI MCR-2-UI-UI - 2902037

Classifications

ETIM

ETIM 4.0	EC002540
ETIM 5.0	EC002653

UNSPSC

UNSPSC 6.01	30211502
UNSPSC 7.0901	39121004
UNSPSC 11	39121004
UNSPSC 12.01	39121004
UNSPSC 13.2	39121004

Approvals

Approvals

Approvals

UL Listed / cUL Listed / GL / cULus Listed

Ex Approvals

ATEX / UL Listed / cUL Listed / cULus Listed

Approvals submitted

Approval details

UL Listed 

cUL Listed 
--

GL

Signal conditioner - MINI MCR-2-UI-UI - 2902037

Approvals



Drawings

Pictogram



Block diagram

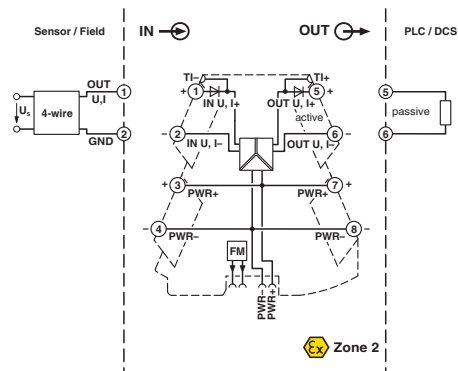

Pictogram

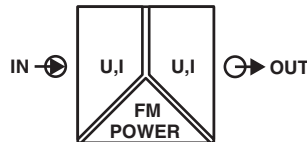

Компания «Life Electronics» занимается поставками электронных компонентов импортного и отечественного производства от производителей и со складов крупных дистрибьюторов Европы, Америки и Азии.

С конца 2013 года компания активно расширяет линейку поставок компонентов по направлению коаксиальный кабель, кварцевые генераторы и конденсаторы (керамические, пленочные, электролитические), за счёт заключения дистрибьюторских договоров

Мы предлагаем:

- Конкурентоспособные цены и скидки постоянным клиентам.
- Специальные условия для постоянных клиентов.
- Подбор аналогов.
- Поставку компонентов в любых объемах, удовлетворяющих вашим потребностям.
- Приемлемые сроки поставки, возможна ускоренная поставка.
- Доставку товара в любую точку России и стран СНГ.
- Комплексную поставку.
- Работу по проектам и поставку образцов.
- Формирование склада под заказчика.
- Сертификаты соответствия на поставляемую продукцию (по желанию клиента).
- Тестирование поставляемой продукции.
- Поставку компонентов, требующих военную и космическую приемку.
- Входной контроль качества.
- Наличие сертификата ISO.

В составе нашей компании организован Конструкторский отдел, призванный помогать разработчикам, и инженерам.

Конструкторский отдел помогает осуществить:

- Регистрацию проекта у производителя компонентов.
- Техническую поддержку проекта.
- Защиту от снятия компонента с производства.
- Оценку стоимости проекта по компонентам.
- Изготовление тестовой платы монтаж и пусконаладочные работы.



Тел: +7 (812) 336 43 04 (многоканальный)

Email: org@lifeelectronics.ru