

---

## Dual push-button Smart Reset™ with capacitor-adjustable delays

---

### Features

- Dual Smart Reset™ push-button inputs with capacitor-adjustable extended reset setup delay ( $t_{SRC}$ )
- Capacitor-adjustable reset pulse duration ( $t_{REC}$ )
- Power-on reset
  - $\overline{RST}$  active-low, open-drain
- Factory-programmable thresholds to monitor  $V_{CC}$  in the range of 1.575 to 4.625 V typ.
- Operating voltage 1.0 V (active-low output valid) to 5.5 V
- Low supply current (1.4  $\mu$ A)
- Operating temperature: industrial grade  $-40\text{ }^{\circ}\text{C}$  to  $+85\text{ }^{\circ}\text{C}$
- TDFN8 package: 2 mm x 2 mm x 0.75 mm
- RoHS compliant

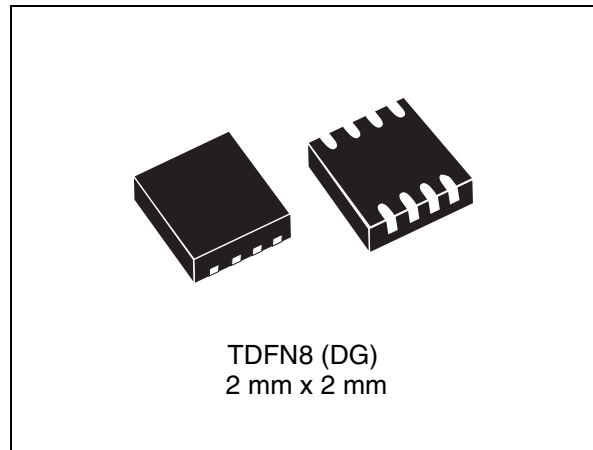

### Applications

- Mobile phones, smartphones
- e-books
- MP3 players
- Games
- Portable navigation devices
- Any application that requires delayed reset push-button(s) response for improved system stability

# Contents

<b>1</b>	<b>Description</b> .....	<b>5</b>
1.1	Smart Reset™ devices .....	5
1.2	STM6510 .....	5
1.3	Pin descriptions .....	9
1.3.1	Power supply ( $V_{CC}$ ) .....	9
1.3.2	Ground ( $V_{SS}$ ) .....	9
1.3.3	Smart Reset™ push-button inputs ( $\overline{SR0}$ , $\overline{SR1}$ ) .....	9
1.3.4	Adjustable delay of Smart Reset™ input (SRC pin) .....	9
1.3.5	Reset output ( $\overline{RST}$ ) .....	10
1.3.6	Adjustable reset timeout ( $TREC_{ADJ}$ pin) .....	10
<b>2</b>	<b>Typical operating characteristics</b> .....	<b>11</b>
<b>3</b>	<b>Maximum ratings</b> .....	<b>13</b>
<b>4</b>	<b>DC and AC parameters</b> .....	<b>14</b>
<b>5</b>	<b>Package mechanical data</b> .....	<b>17</b>
<b>6</b>	<b>Part numbering</b> .....	<b>23</b>
<b>7</b>	<b>Package marking</b> .....	<b>24</b>
<b>8</b>	<b>Revision history</b> .....	<b>25</b>

## List of tables

Table 1.	Signal names . . . . .	6
Table 2.	tSRC programmed by an ideal external capacitor . . . . .	9
Table 3.	tREC programmed by an ideal external capacitor . . . . .	10
Table 4.	Absolute maximum ratings . . . . .	13
Table 5.	Operating and measurement conditions . . . . .	14
Table 6.	DC and AC characteristics . . . . .	15
Table 7.	Possible VCC voltage thresholds . . . . .	16
Table 8.	TDFN – 8-lead 2 x 2 x 0.75 mm, 0.5 mm pitch package mechanical data . . . . .	18
Table 9.	Parameter for landing pattern - TDFN – 8-lead 2 x 2 mm package . . . . .	19
Table 10.	Carrier tape dimensions . . . . .	20
Table 11.	Reel dimensions . . . . .	21
Table 12.	Ordering information scheme . . . . .	23
Table 13.	Package marking . . . . .	24
Table 14.	Document revision history . . . . .	25

## List of figures

Figure 1.	Logic diagram . . . . .	6
Figure 2.	Pin connections . . . . .	6
Figure 3.	Block diagram . . . . .	7
Figure 4.	Single-button Smart Reset™ typical hookup . . . . .	8
Figure 5.	Dual-button Smart Reset™ typical hookup. . . . .	8
Figure 6.	Timing waveforms. . . . .	9
Figure 7.	Supply current ( $I_{CC}$ ) vs. temperature . . . . .	11
Figure 8.	Smart Reset™ delay ( $t_{SRC}$ ) vs. temperature, $C_{SRC} = 0.56 \mu F$ . . . . .	11
Figure 9.	Reset timeout period ( $t_{REC}$ ) vs. temperature, $C_{tREC} = 0.01 \mu F$ . . . . .	12
Figure 10.	Reset threshold ( $V_{RST}$ ) vs. temperature, “S” threshold option, $V_{CC}$ falling. . . . .	12
Figure 11.	AC testing input/output waveforms . . . . .	14
Figure 12.	TDFN – 8-lead 2 x 2 x 0.75 mm, 0.5 mm pitch package outline. . . . .	18
Figure 13.	Landing pattern - TDFN – 8-lead 2 x 2 mm without thermal pad . . . . .	19
Figure 14.	Carrier tape . . . . .	20
Figure 15.	Reel dimensions . . . . .	21
Figure 16.	Tape trailer/leader. . . . .	22
Figure 17.	Pin 1 orientation . . . . .	22
Figure 18.	Package marking, top view. . . . .	24

# 1 Description

## 1.1 Smart Reset™ devices

The Smart Reset™ device family STM65xx provides a useful feature that ensures inadvertent short reset push-button closures do not cause system resets. This is done by implementing an extended Smart Reset™ input delay ( $t_{SRC}$ ). Once the valid Smart Reset™ input levels and setup delay are met, the device generates an output reset pulse with user-programmable timeout period ( $t_{REC}$ ).

The typical application hookup shows that the dual Smart Reset™ inputs can be also connected to the applications interrupt to allow the control of both the interrupt pin and the hard reset functions. If the push-buttons are closed for a short time, the processor is only interrupted. If the system still does not respond properly, holding the push-buttons for the extended setup time ( $t_{SRC}$ ) causes a hard reset of the processor through the reset output. The Smart Reset™ feature helps significantly increase system stability.

The STM65xx family of Smart Reset™ devices consists of low-current microprocessor reset circuits targeted at applications such as MP3 players, portable navigation devices or mobile phones, generally any application that requires delayed reset push-button(s) response for improved system stability. The STM65xx devices feature single or dual Smart Reset™ inputs (SRx). The delayed Smart Reset™ setup time ( $t_{SRC}$ ) options are adjustable by adding an external capacitor on the SRC pin or selectable by three-state logic. The delayed setup period ignores switch closures shorter than  $t_{SRC}$ , thus preventing undesired resets.

The STM65xx devices have active-low (optionally active-high) open-drain reset ( $\overline{RST}$ ) output(s) with or without an internal pull-up resistor or push-pull as output options, with or without the power-on reset function.

Some devices also have an undervoltage monitoring feature: the reset output is also asserted when the monitored supply voltage  $V_{CC}$  drops below the specified threshold. The reset output remains asserted for the reset timeout period ( $t_{REC}$ ) after the monitored supply voltage goes above the specified threshold.

## 1.2 STM6510

The STM6510 has two combined Smart Reset™ inputs ( $\overline{SR0}$  and  $\overline{SR1}$ ) with Smart Reset™ setup delay ( $t_{SRC}$ ) programmed by an external capacitor on the SRC pin. An additional STM6510 feature is adjustable output reset pulse time  $t_{REC}$  by adding an external capacitor ( $C_{tREC}$ ).

Additionally, the  $V_{CC}$  is monitored and if it drops below the selected  $V_{RST}$  threshold, the reset output goes active and remains active while  $V_{CC}$  is below the  $V_{RST}$  threshold, plus the defined duration of the reset pulse  $t_{REC}$ .

Figure 1. Logic diagram

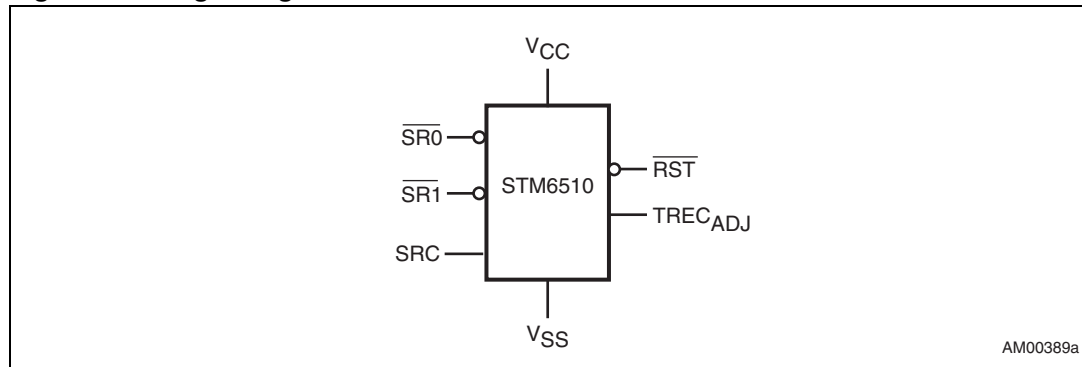

Figure 2. Pin connections

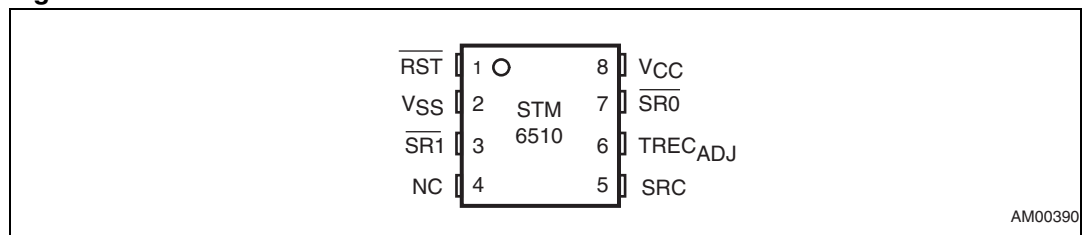

Table 1. Signal names

Symbol	Input/output	Description
$\overline{RST}$	Output	Reset output, active-low (open-drain).
$\overline{SR0}$	Input	Primary push-button Smart Reset™ input. Active-low, internal 65 kΩ pull-up resistor to $V_{CC}$ .
$\overline{SR1}$	Input	Secondary push-button Smart Reset™ input. Active-low, internal 65 kΩ pull-up resistor to $V_{CC}$ .
SRC	Input	Smart Reset™ input delay setup control. Connect an external capacitor to this pin to adjust the delay setup time ( $t_{SRC}$ ).
TREC <sub>ADJ</sub>	Input	Input pin for $t_{REC}$ reset pulse duration adjustment. Connect an external capacitor ( $C_{TREC}$ ) to this pin to determine $t_{REC}$ .
$V_{CC}$	Supply	Supply voltage input. Power supply for the device and an input for the monitored supply voltage. A 0.1 μF decoupling ceramic capacitor is recommended to be connected between $V_{CC}$ and $V_{SS}$ pins.
$V_{SS}$	Supply	Ground
NC		No connect (not bonded); should be connected to $V_{SS}$ .

Figure 3. Block diagram

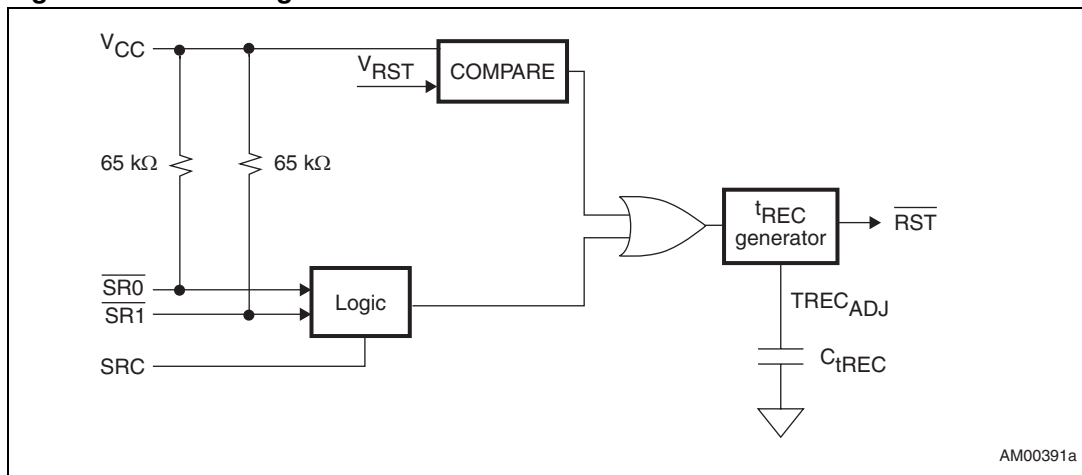
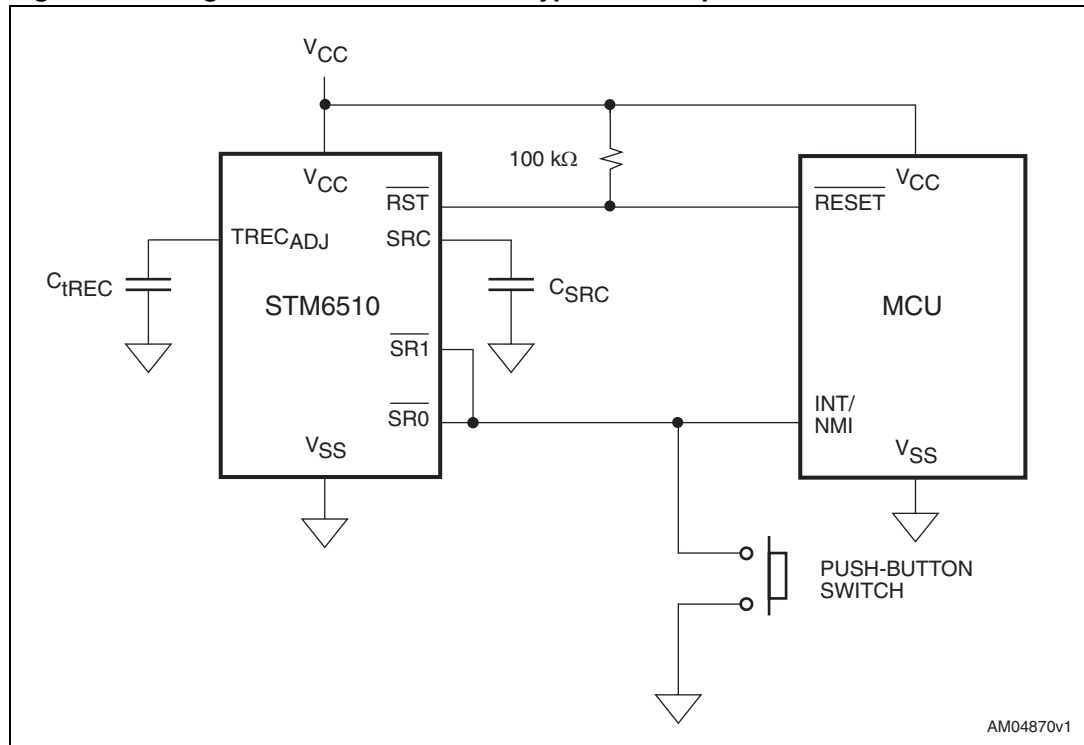
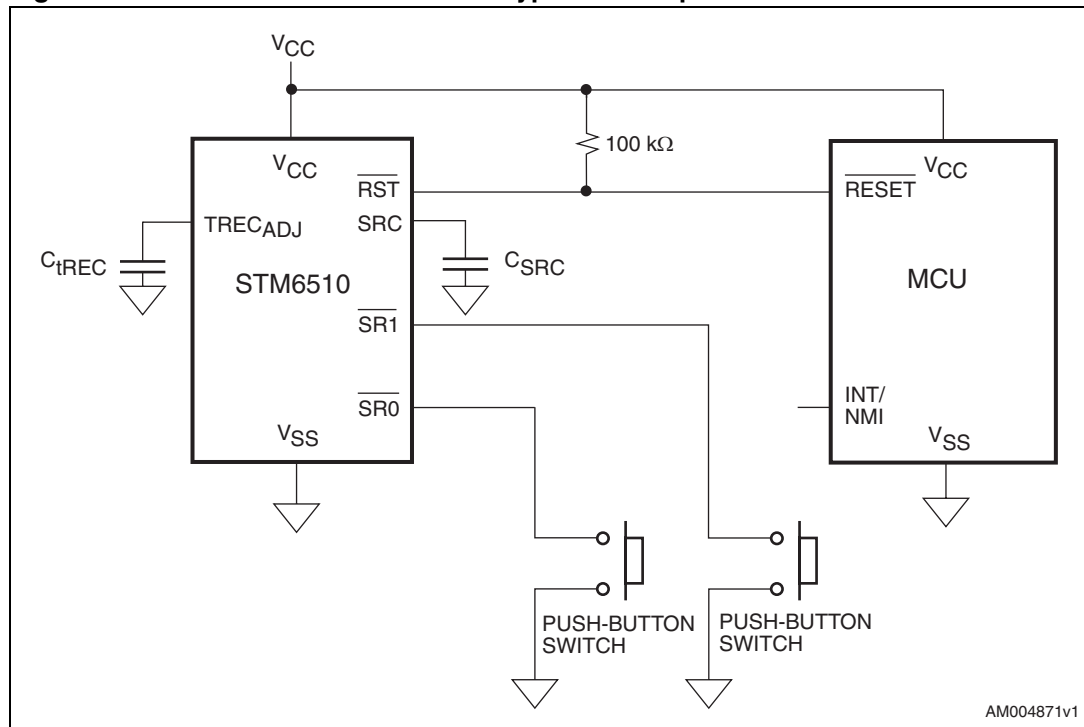

Figure 4. Single-button Smart Reset™ typical hookup



Note: When only one Smart Reset™ input push-button is used, tie both the  $\overline{SR}$  inputs together.

Figure 5. Dual-button Smart Reset™ typical hookup



### 1.3 Pin descriptions

#### 1.3.1 Power supply (V<sub>CC</sub>)

This pin is used to provide the power to the Smart Reset™ device and to monitor the power supply. A 0.1 μF decoupling ceramic capacitor is recommended to be connected between the V<sub>CC</sub> and V<sub>SS</sub> pins.

#### 1.3.2 Ground (V<sub>SS</sub>)

This is the supply ground for the device.

#### 1.3.3 Smart Reset™ push-button inputs (SR<sub>0</sub>, SR<sub>1</sub>)

Both SR<sub>0</sub> and SR<sub>1</sub> need to be held active at the same time for at least t<sub>SRC</sub> to activate the reset output pulse. Include an internal 65 kΩ pull-up resistor to V<sub>CC</sub> for each input.

**Figure 6. Timing waveforms**

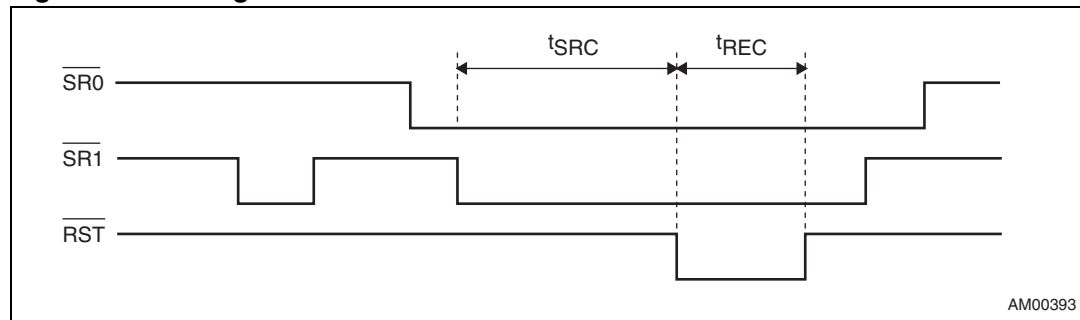

#### 1.3.4 Adjustable delay of Smart Reset™ input (SRC pin)

This pin controls the setup time before the push-button action is validated by the reset output. It is connected to an external capacitor (C<sub>SRC</sub>), which is tied to ground to provide the desired value of setup time (t<sub>SRC</sub>).

Calculated t<sub>SRC</sub> and C<sub>SRC</sub> examples are given in [Table 2](#). Refer also to [Table 6](#).

**Table 2. t<sub>SRC</sub> programmed by an ideal external capacitor**

Calculated C <sub>SRC</sub> value [μF]	Setup delay t <sub>SRC</sub> [s] <sup>(1)(2)</sup>			Closest common C <sub>SRC</sub> value [μF]
	Min.	Typ.	Max.	
0.2	2	3	4	0.22
0.3	3	4.5	6	0.33
0.6	6	9	12	0.56
1	10	15	20	1

1. Example calculations based on an ideal capacitor. During application design and component selection it should be considered that the current flowing into the external t<sub>SRC</sub> programming capacitor (C<sub>SRC</sub>) is on the order of 100 nA, therefore a low-leakage capacitor (ceramic or film capacitor) and an adequate PCB environment should be used to prevent t<sub>SRC</sub> accuracy from being affected. A recommended minimum value of C<sub>SRC</sub> is 0.01 μF.
2. In case of repeated activations of the t<sub>SRC</sub> counter, an interval of 10 ms min. is needed between the activations to fully discharge C<sub>SRC</sub>, so that the next t<sub>SRC</sub> is as specified.

### 1.3.5 Reset output ( $\overline{\text{RST}}$ )

$\overline{\text{RST}}$  is active-low, open-drain.

### 1.3.6 Adjustable reset timeout ( $\text{TREC}_{\text{ADJ}}$ pin)

The reset timeout ( $t_{\text{REC}}$ ) is adjustable by connecting an external capacitor  $C_{\text{tREC}}$  to this pin. Calculated  $t_{\text{REC}}$  and  $C_{\text{tREC}}$  examples are given in [Table 3](#). Refer also to [Table 6](#).

**Table 3.  $t_{\text{REC}}$  programmed by an ideal external capacitor**

Calculated $C_{\text{tREC}}$ value [ $\mu\text{F}$ ]	$t_{\text{REC}}$ [ms] <sup>(1)(2)</sup>			Closest common $C_{\text{tREC}}$ value [ $\mu\text{F}$ ]
	Min.	Typ.	Max.	
0.001	10	15	20	0.001
0.002	20	30	40	0.0022
0.01	100	150	200	0.01
0.014	140	210	280	0.015
0.028	280	420	560	0.027
0.056	560	840	1120	0.056
0.112	1120	1680	2240	0.1

1. Example calculations based on an ideal capacitor. During application design and component selection it should be considered that the current flowing into the external  $t_{\text{REC}}$  programming capacitor ( $C_{\text{tREC}}$ ) is on the order of 100 nA, therefore a low-leakage capacitor (ceramic or film capacitor) and an adequate PCB environment should be used to prevent  $t_{\text{REC}}$  accuracy from being affected. A recommended minimum value of  $C_{\text{tREC}}$  is 0.001  $\mu\text{F}$ .
2. In case of repeated activations of the  $t_{\text{REC}}$  counter, an interval of 10 ms min. is needed between  $t_{\text{REC}}$  intervals to fully discharge  $C_{\text{tREC}}$ , so that the next  $t_{\text{REC}}$  is as specified.

## 2 Typical operating characteristics

Figure 7. Supply current ( $I_{CC}$ ) vs. temperature

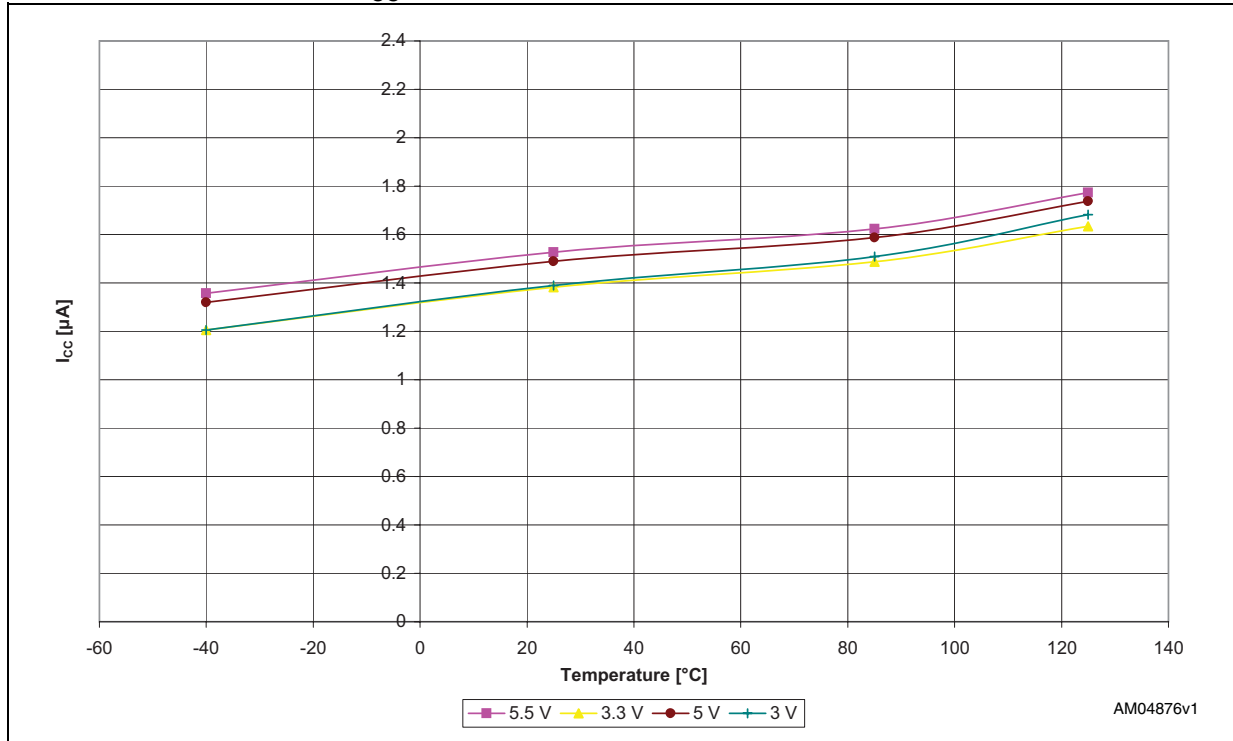

Figure 8. Smart Reset™ delay ( $t_{SRC}$ ) vs. temperature,  $C_{SRC} = 0.56 \mu$ F

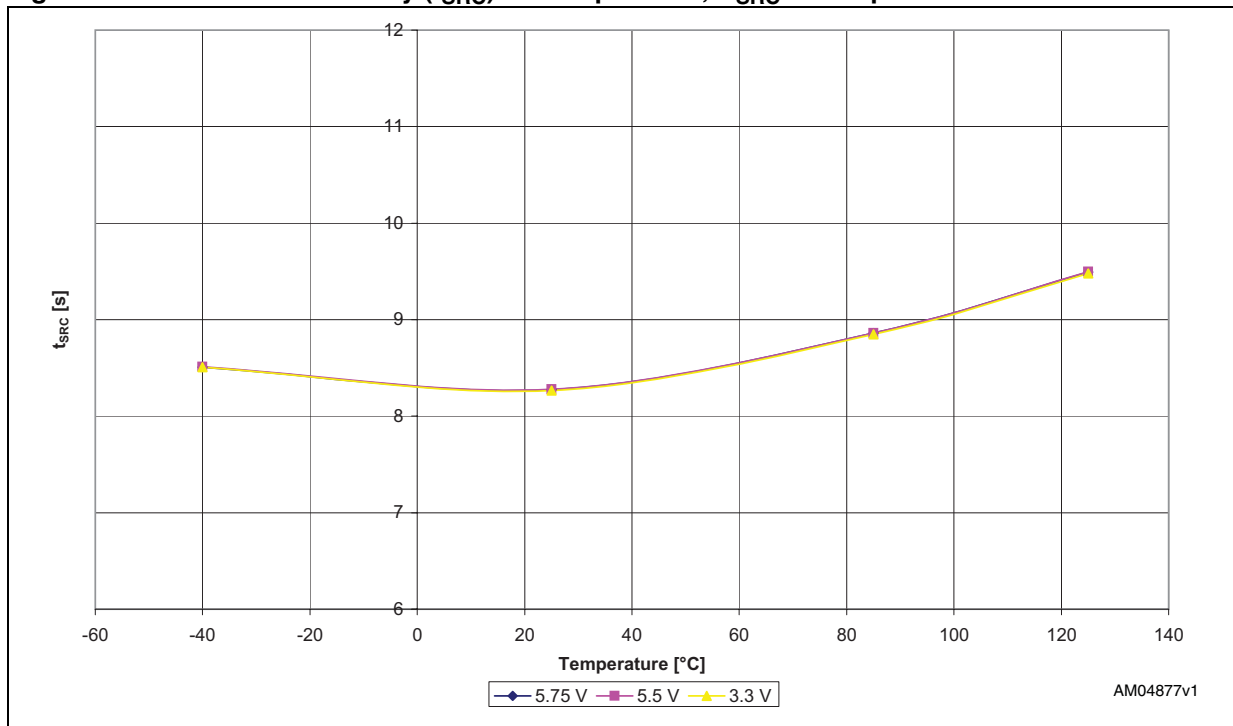

Figure 9. Reset timeout period ( $t_{REC}$ ) vs. temperature,  $C_{tREC} = 0.01 \mu F$

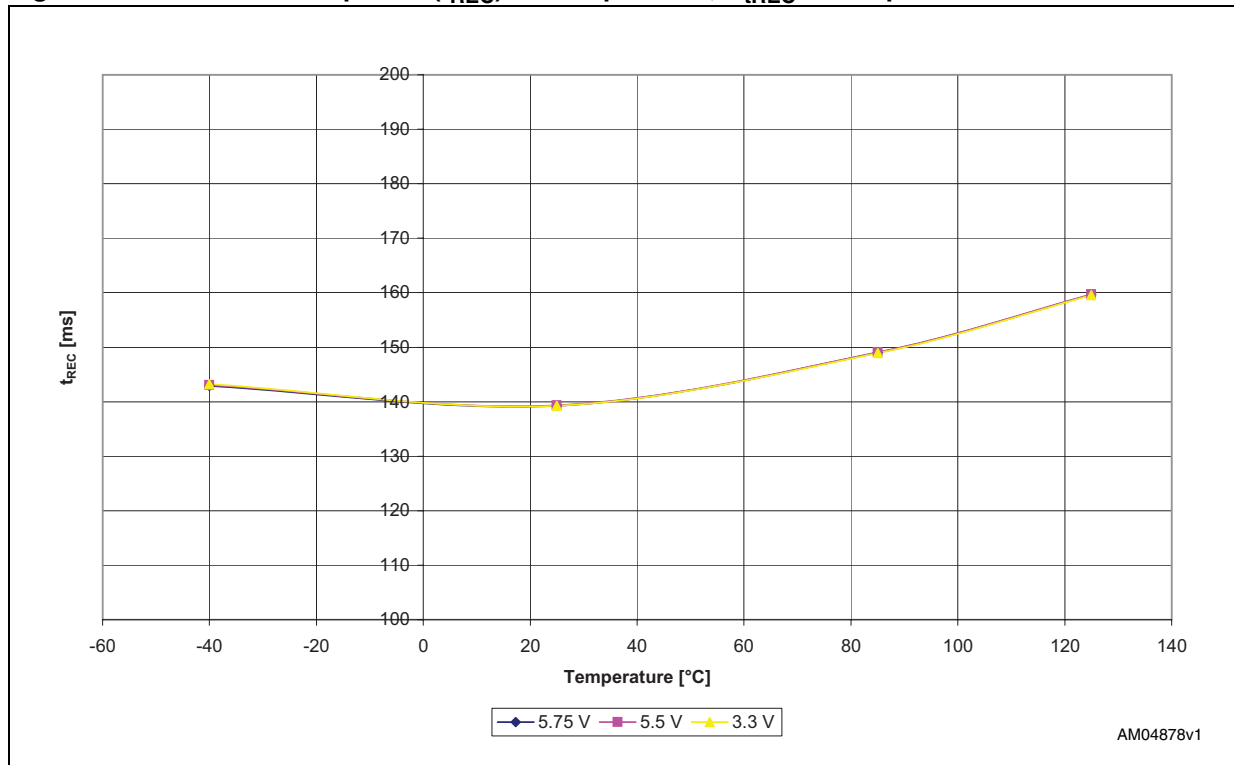
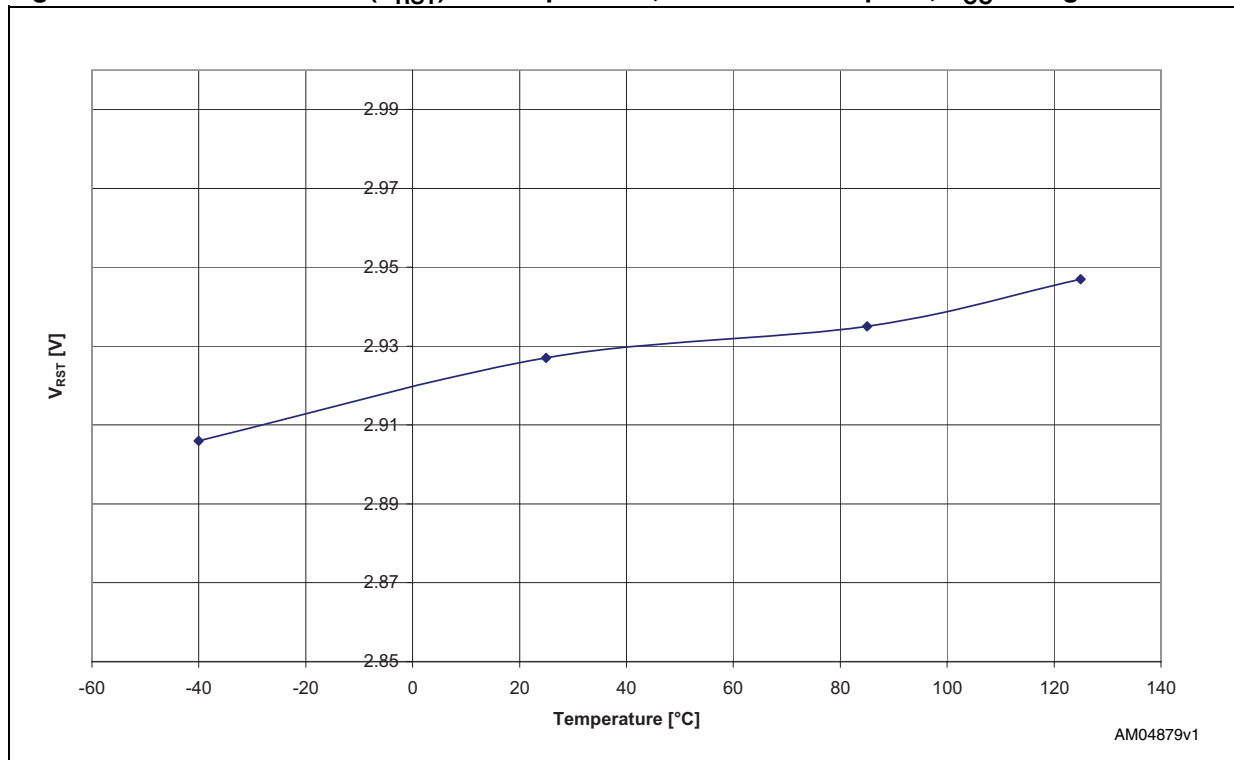

Figure 10. Reset threshold ( $V_{RST}$ ) vs. temperature, “S” threshold option,  $V_{CC}$  falling



### 3 Maximum ratings

Stressing the device above the rating listed in the [Table 4: Absolute maximum ratings](#) may cause permanent damage to the device. These are stress ratings only and operation of the device at these or any other conditions above those indicated in the Operating sections of this specification is not implied. Exposure to absolute maximum rating conditions for extended periods may affect device reliability. Refer also to the STMicroelectronics™ SURE Program and other relevant quality documents.

**Table 4. Absolute maximum ratings**

Symbol	Parameter		Value	Unit
$T_{STG}$	Storage temperature ( $V_{CC}$ off)		-55 to +150	°C
$T_{SLD}^{(1)}$	Lead solder temperature for 10 seconds		260	°C
$\theta_{JA}$	Thermal resistance (junction to ambient)	TDFN8	149.0	°C/W
$V_{IO}$	Input or output voltage		-0.3 to $V_{CC} + 0.3$	V
$V_{CC}$	Supply voltage		-0.3 to 7	V

1. Reflow at peak temperature of 260 °C. The time above 255 °C must not exceed 30 seconds.

## 4 DC and AC parameters

This section summarizes the operating measurement conditions, and the DC and AC characteristics of the device. The parameters in the [Table 6: DC and AC characteristics](#) that follow, are derived from tests performed under the Measurement Conditions summarized in [Table 5: Operating and measurement conditions](#). Designers should check that the operating conditions in their circuit match the operating conditions when relying on the quoted parameters.

**Table 5. Operating and measurement conditions**

Parameter	Value	Unit
V <sub>CC</sub> supply voltage	1.0 to 5.5	V
Ambient operating temperature (T <sub>A</sub> )	-40 to +85	°C
Input rise and fall times	≤ 5	ns
Input pulse voltages	0.2 to 0.8 V <sub>CC</sub>	V
Input and output timing ref. voltages	0.3 to 0.7 V <sub>CC</sub>	V

**Figure 11. AC testing input/output waveforms**

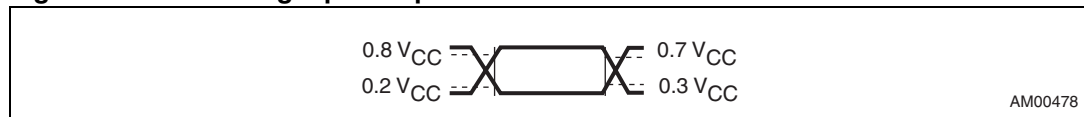

Table 6. DC and AC characteristics

Symbol	Parameter	Test conditions <sup>(1)</sup>	Min.	Typ. <sup>(2)</sup>	Max.	Units
V <sub>CC</sub>	Supply voltage range	Reset output valid - active-low	1.0		5.5	V
I <sub>CC</sub>	Supply current (V <sub>CC</sub> )	V <sub>CC</sub> = 5.0 V		1.5	2.4	μA
		V <sub>CC</sub> = 3.0 V <sup>(3)</sup>		1.4		μA
V <sub>OL</sub>	Reset output voltage low	V <sub>CC</sub> ≥ 4.5 V, sinking 3.2 mA			0.3	V
		V <sub>CC</sub> ≥ 3.3 V, sinking 2.5 mA			0.3	V
		V <sub>CC</sub> ≥ 1.0 V, sinking 0.1 mA			0.3	V
V <sub>RST</sub>	V <sub>CC</sub> undervoltage reset threshold (refer to <a href="#">Table 7</a> )	-40 to +85 °C	V <sub>RST</sub> -2.5%	V <sub>RST</sub>	V <sub>RST</sub> +2.5%	V
		25 °C	V <sub>RST</sub> -2.0%	V <sub>RST</sub>	V <sub>RST</sub> +2.0%	V
V <sub>HYST</sub>	Hysteresis of V <sub>RST</sub>	L, M		0.5%		
		T, S, R, Z, Y, W, V		1%		
	V <sub>CC</sub> to reset delay <sup>(4)</sup>	V <sub>CC</sub> falling from (V <sub>RST</sub> + 100 mV) to (V <sub>RST</sub> - 100 mV) at 10 mV/μs		20		μs
t <sub>REC</sub> <sup>(4)</sup>	User-adjustable reset timeout period on RST. Refer to <a href="#">Table 3</a> .		10 000 x C <sub>tREC</sub> (μF)	15 000 x C <sub>tREC</sub> (μF)	20 000 x C <sub>tREC</sub> (μF)	ms
<b>Smart Reset™ inputs</b>						
t <sub>SRC</sub> <sup>(5)</sup>	User-adjustable delayed Smart Reset™ setup time. Refer to <a href="#">Table 2</a> .		10 x C <sub>SRC</sub> (μF)	15 x C <sub>SRC</sub> (μF)	20 x C <sub>SRC</sub> (μF)	s
V <sub>IL</sub>	$\overline{SR0}$ , $\overline{SR1}$ input voltage low				0.3 V <sub>CC</sub>	V
V <sub>IH</sub>	$\overline{SR0}$ , $\overline{SR1}$ input voltage high		0.7 V <sub>CC</sub>			V
R <sub>PUI</sub>	Internal pull-up resistor, $\overline{SR0}$ , $\overline{SR1}$ inputs			65		kΩ

- Valid for ambient operating temperature: T<sub>A</sub> = -40 to +85 °C; V<sub>CC</sub> = 1.0 to 5.5 V (except where noted).
- Typical value is at 25 °C and V<sub>CC</sub> = 3.3 V unless otherwise noted.
- For devices with V<sub>RST</sub> < 3.0 V.
- Guaranteed by design.
- Input glitch immunity is equal to t<sub>SRC</sub> (when both SR inputs are low, otherwise infinite).

Table 7. Possible  $V_{CC}$  voltage thresholds

$V_{CC}$ voltage threshold $V_{RST}$	Typ.	$\pm 2.5\%$ ( $-40\text{ }^{\circ}\text{C}$ to $+85\text{ }^{\circ}\text{C}$ )		$\pm 2.0\%$ ( $25\text{ }^{\circ}\text{C}$ )		Unit
		Min.	Max.	Min.	Max.	
L (falling)	4.625	4.509	4.741	4.533	4.718	V
M (falling)	4.375	4.266	4.484	4.288	4.463	V
T (falling)	3.075	2.998	3.152	3.014	3.137	V
S (falling)	2.925	2.852	2.998	2.867	2.984	V
R (falling)	2.625	2.559	2.691	2.573	2.678	V
Z (falling)	2.313	2.255	2.371	2.267	2.359	V
Y (falling)	2.188	2.133	2.243	2.144	2.232	V
W (falling)	1.665	1.623	1.707	1.632	1.698	V
V (falling)	1.575	1.536	1.614	1.544	1.607	V

## 5 Package mechanical data

In order to meet environmental requirements, ST offers these devices in different grades of ECOPACK<sup>®</sup> packages, depending on their level of environmental compliance. ECOPACK<sup>®</sup> specifications, grade definitions and product status are available at: [www.st.com](http://www.st.com). ECOPACK<sup>®</sup> is an ST trademark.

Figure 12. TDFN – 8-lead 2 x 2 x 0.75 mm, 0.5 mm pitch package outline

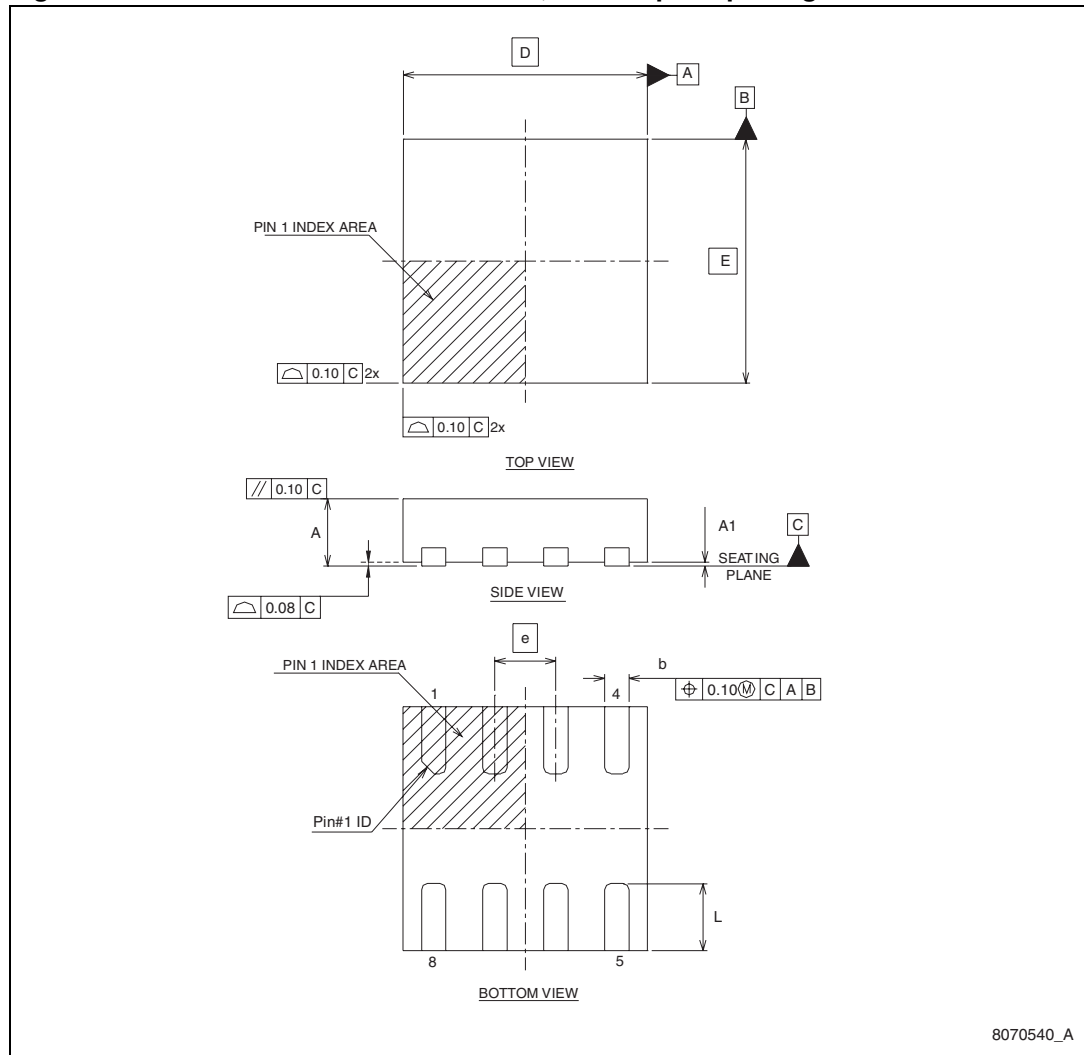

Table 8. TDFN – 8-lead 2 x 2 x 0.75 mm, 0.5 mm pitch package mechanical data

Symbol	Dimension (mm)			Dimension (inches)		
	Min.	Nom.	Max.	Min.	Nom.	Max.
A	0.70	0.75	0.80	0.028	0.030	0.031
A1	0.00	0.02	0.05	0.000	0.001	0.002
b	0.15	0.20	0.25	0.006	0.008	0.010
D BSC		2.00			0.079	
E BSC		2.00			0.079	
e		0.50			0.020	
L	0.45	0.55	0.65	0.018	0.022	0.026

Figure 13. Landing pattern - TDFN – 8-lead 2 x 2 mm without thermal pad

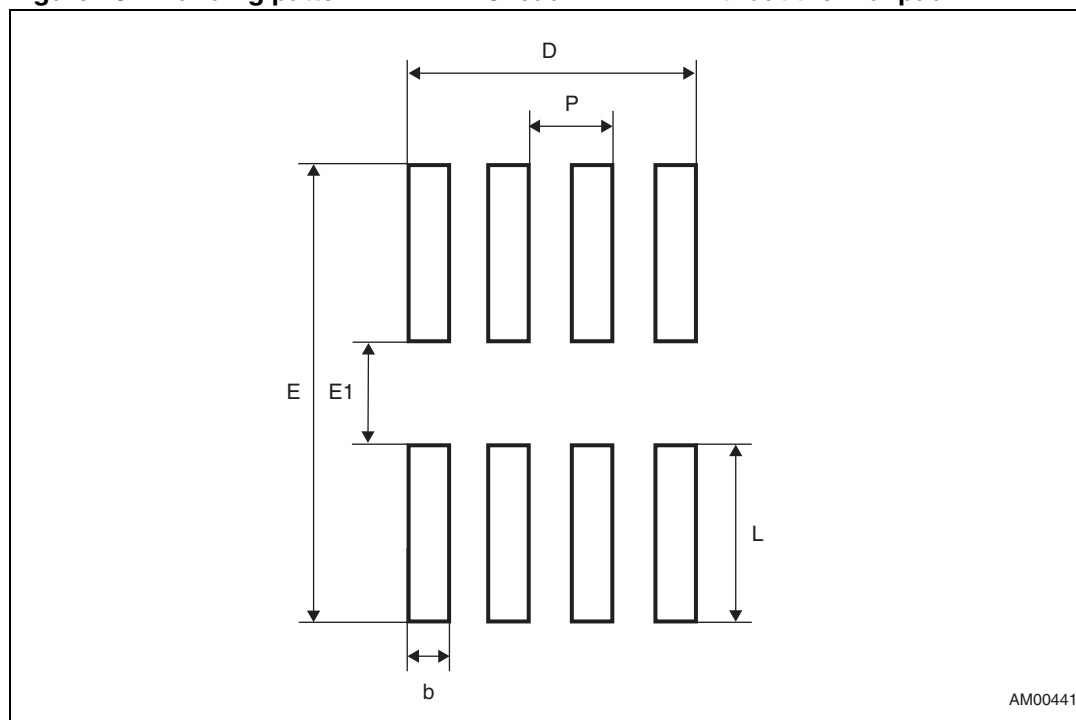

Table 9. Parameter for landing pattern - TDFN – 8-lead 2 x 2 mm package

Parameter	Description	Dimension (mm)		
		Min.	Nom.	Max.
L	Contact length	1.05	—	1.15
b	Contact width	0.25	—	0.30
E	Max. land pattern Y-direction	—	2.75	—
E1	Contact gap spacing	—	0.65	—
D	Max. land pattern X-direction	—	1.75	—
P	Contact pitch	—	0.5	—

Figure 14. Carrier tape

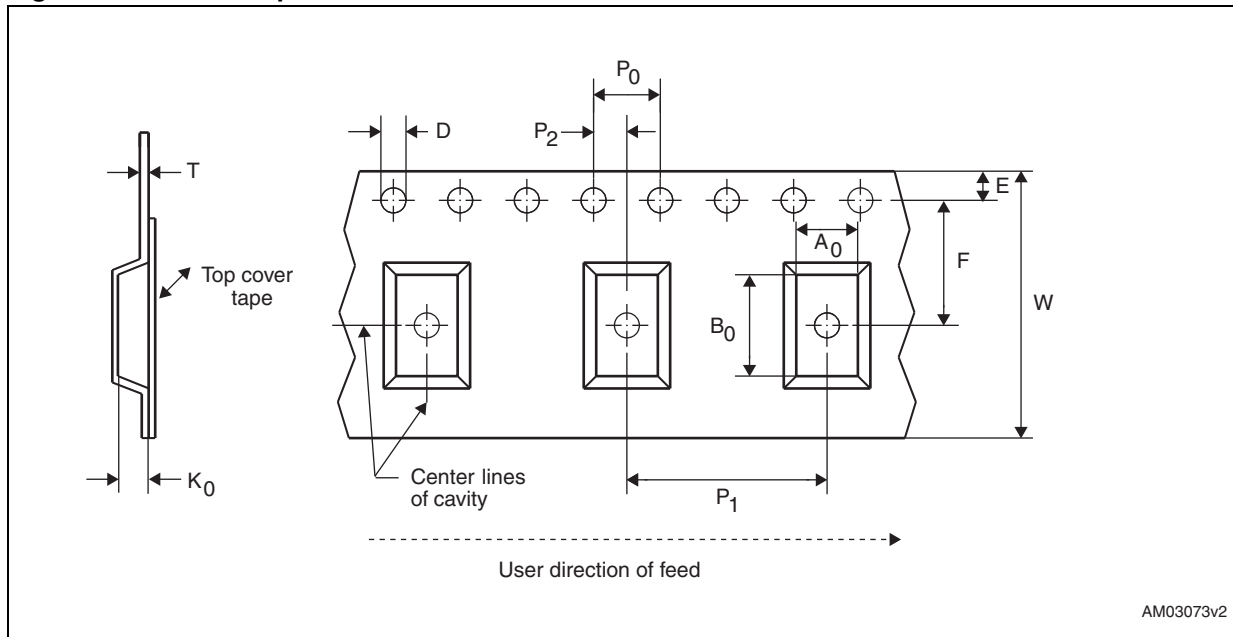

Table 10. Carrier tape dimensions

Package	W	D	E	P <sub>0</sub>	P <sub>2</sub>	F	A <sub>0</sub>	B <sub>0</sub>	K <sub>0</sub>	P <sub>1</sub>	T	Unit	Bulk qty.
TDFN8	8.00 +0.30 -0.10	1.50 +0.10/ -0.00	1.75 ±0.10	4.00 ±0.10	2.00 ±0.10	3.50 ±0.05	2.30 ±0.05	2.30 ±0.05	1.00 ±0.05	4.00 ±0.10	0.250 ±0.05	mm	3000

Figure 15. Reel dimensions

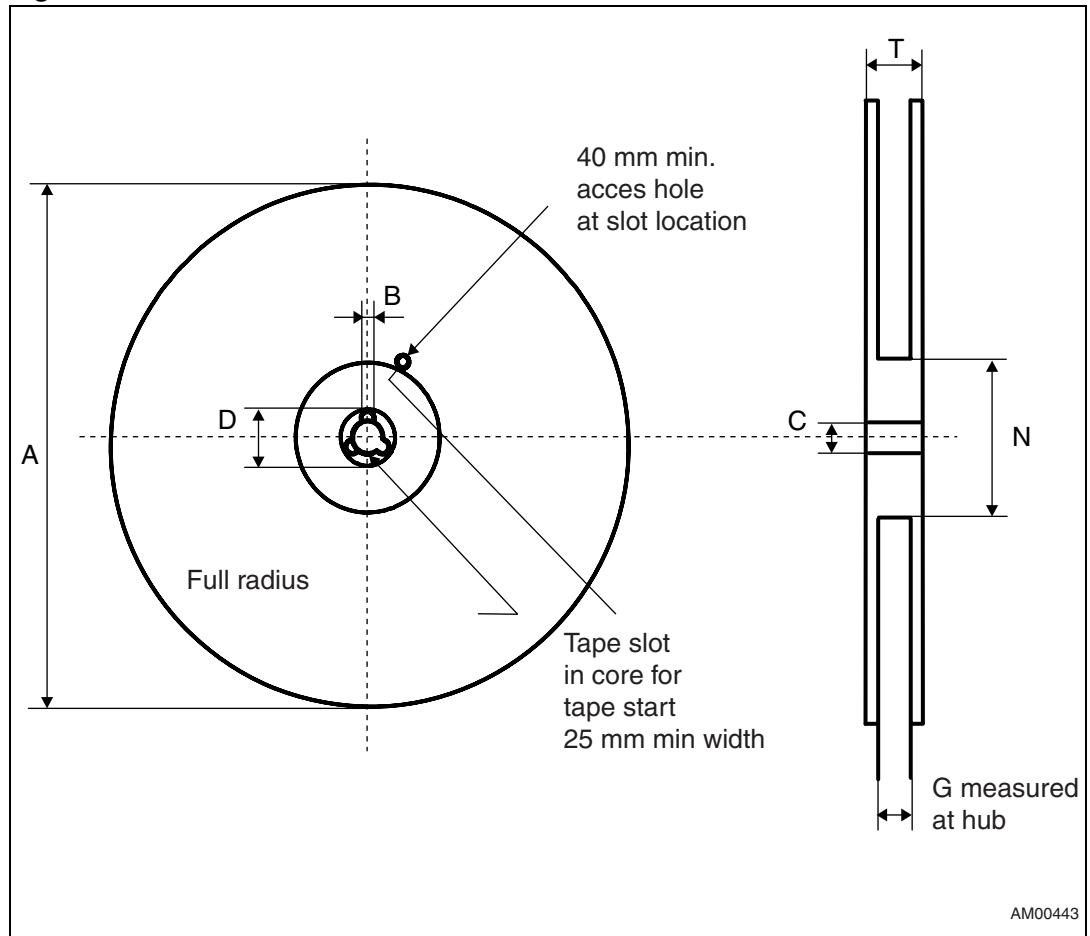

Table 11. Reel dimensions

Tape sizes	A max.	B min.	C	D min.	N min.	G	T max.
8 mm	180 (7 inches)	1.50	13.0 +/- 0.20	20.20	60	8.4 +2/-0	14.40

Figure 16. Tape trailer/leader

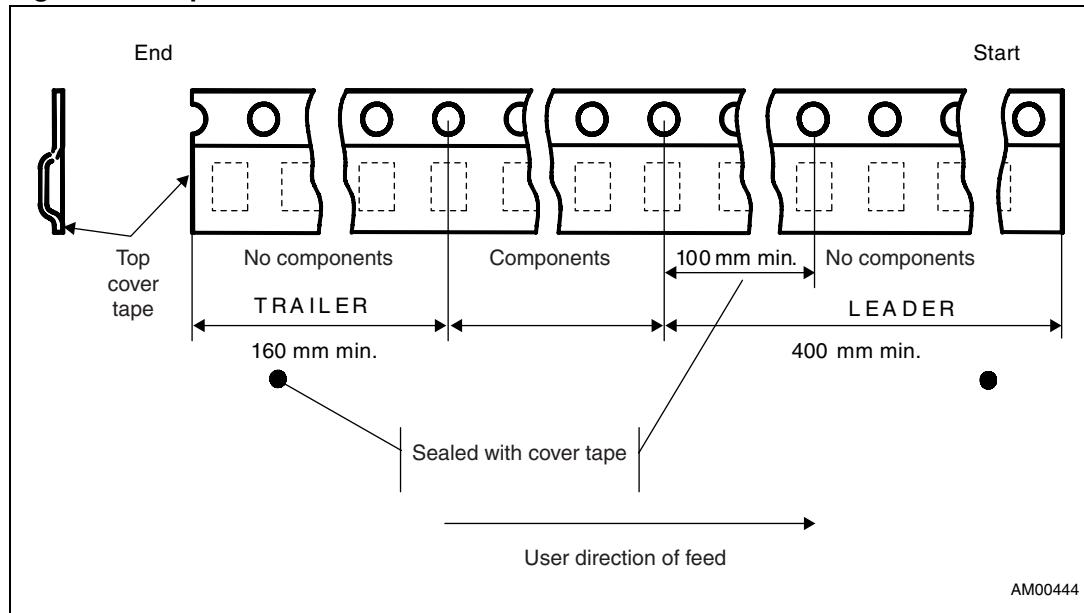
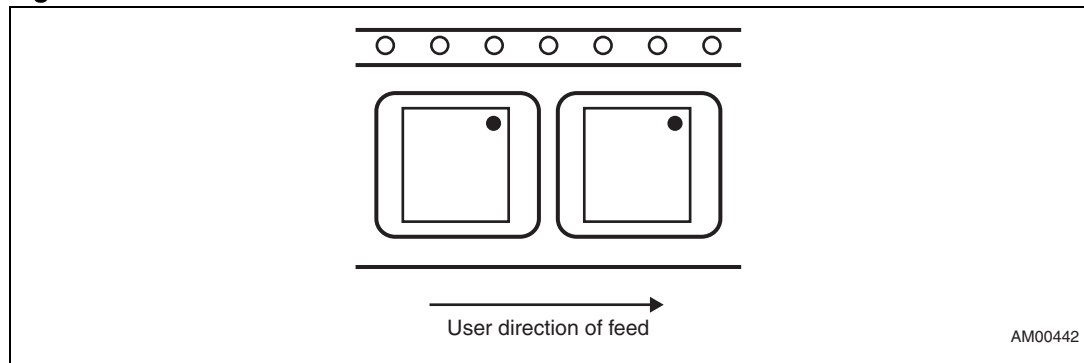

Figure 17. Pin 1 orientation



- Note: 1 Drawings are not to scale.  
 2 All dimensions are in mm, unless otherwise noted.

## 6 Part numbering

**Table 12. Ordering information scheme**

Example:

STM6510 W C A C DG 6 F

**Device type**

STM6510

**Reset ( $V_{CC}$  monitoring threshold) voltage  $V_{RST}$**

L = 4.625 V (typ., falling)

M = 4.375 V

T = 3.075 V

S = 2.925 V

R = 2.625 V

Z = 2.313 V

Y = 2.188 V

W = 1.665 V

V = 1.575 V

**Smart Reset™ setup delay control ( $t_{SRC}$ ); presence of internal input pull-up on all Smart Reset™ inputs ( $\overline{SR0}$ ,  $\overline{SR1}$ )**

C = 1 to 15 s, user-programmable (external capacitor); 65 k $\Omega$  input pull-up

**Output type**

A = open-drain, active-low

**Reset timeout period ( $t_{REC}$ )**

C = user-programmable (external capacitor)

**Package**

DG = TDFN8 - 2 x 2 x 0.75 mm, 0.5 mm pitch

**Temperature range**

6 = -40 °C to +85 °C

**Shipping method**

F = ECOPACK® package, tape and reel

For device options currently available refer to [Table 13](#). For other options, voltage threshold values etc. or for more information on any aspect of this device, please contact the ST sales office nearest you.

## 7 Package marking

**Table 13. Package marking**

Part name	t <sub>SRC</sub> delay control	Smart Reset™ inputs type	V <sub>RST</sub>	Reset output type	t <sub>REC</sub> programming	Topmark
STM6510WCACDG6F	C <sub>SRC</sub>	AL, PU	W	AL, OD	C <sub>tREC</sub>	8WK
STM6510SCACDG6F	C <sub>SRC</sub>	AL, PU	S	AL, OD	C <sub>tREC</sub>	8SK
STM6510RCACDG6F	C <sub>SRC</sub>	AL, PU	R	AL, OD	C <sub>tREC</sub>	8RK

Note: AL = Active-Low, AH = Active-High; PU = with internal pull-up resistor, OD = Open-Drain.

**Figure 18. Package marking, top view**

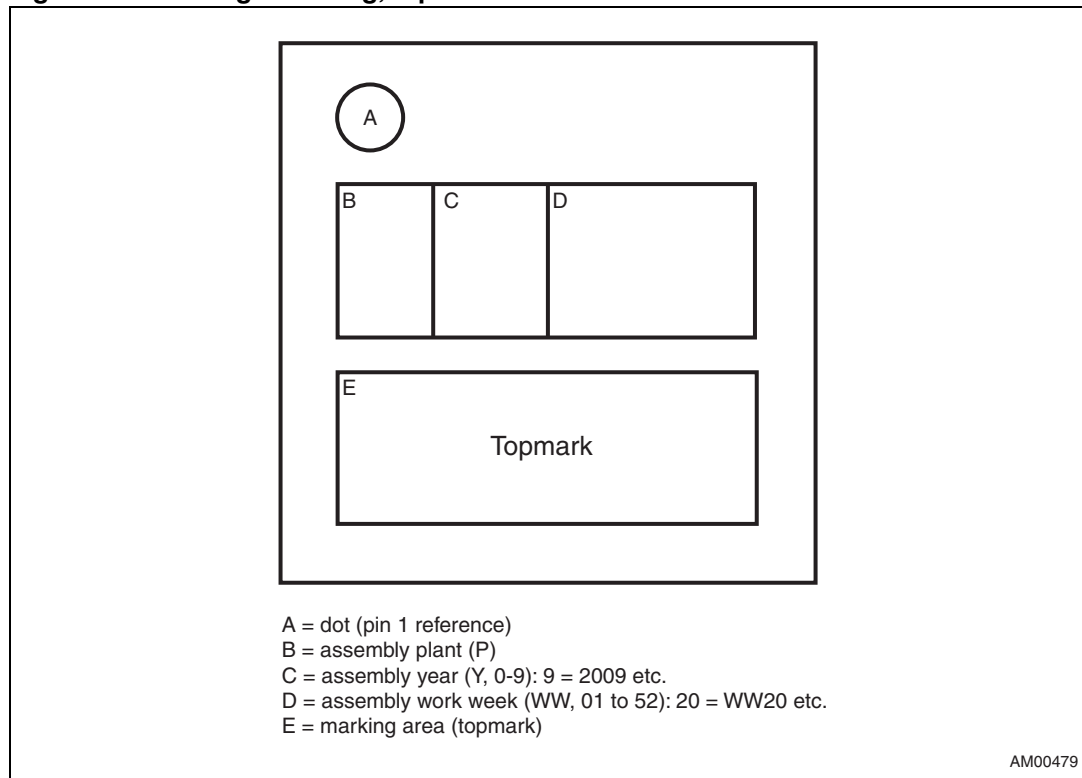

## 8 Revision history

Table 14. Document revision history

Date	Revision	Changes
12-Feb-2010	1	Initial release.
26-Feb-2010	2	Updated title of datasheet, <i>Features, Applications</i> ; updated footnote 1 of <i>Table 2</i> ; updated <i>Table 6, 12, 13; Figure 3; Section 1.3.3</i> ; minor textual and formatting changes.

**Please Read Carefully:**

Information in this document is provided solely in connection with ST products. STMicroelectronics NV and its subsidiaries ("ST") reserve the right to make changes, corrections, modifications or improvements, to this document, and the products and services described herein at any time, without notice.

All ST products are sold pursuant to ST's terms and conditions of sale.

Purchasers are solely responsible for the choice, selection and use of the ST products and services described herein, and ST assumes no liability whatsoever relating to the choice, selection or use of the ST products and services described herein.

No license, express or implied, by estoppel or otherwise, to any intellectual property rights is granted under this document. If any part of this document refers to any third party products or services it shall not be deemed a license grant by ST for the use of such third party products or services, or any intellectual property contained therein or considered as a warranty covering the use in any manner whatsoever of such third party products or services or any intellectual property contained therein.

**UNLESS OTHERWISE SET FORTH IN ST'S TERMS AND CONDITIONS OF SALE ST DISCLAIMS ANY EXPRESS OR IMPLIED WARRANTY WITH RESPECT TO THE USE AND/OR SALE OF ST PRODUCTS INCLUDING WITHOUT LIMITATION IMPLIED WARRANTIES OF MERCHANTABILITY, FITNESS FOR A PARTICULAR PURPOSE (AND THEIR EQUIVALENTS UNDER THE LAWS OF ANY JURISDICTION), OR INFRINGEMENT OF ANY PATENT, COPYRIGHT OR OTHER INTELLECTUAL PROPERTY RIGHT.**

**UNLESS EXPRESSLY APPROVED IN WRITING BY AN AUTHORIZED ST REPRESENTATIVE, ST PRODUCTS ARE NOT RECOMMENDED, AUTHORIZED OR WARRANTED FOR USE IN MILITARY, AIR CRAFT, SPACE, LIFE SAVING, OR LIFE SUSTAINING APPLICATIONS, NOR IN PRODUCTS OR SYSTEMS WHERE FAILURE OR MALFUNCTION MAY RESULT IN PERSONAL INJURY, DEATH, OR SEVERE PROPERTY OR ENVIRONMENTAL DAMAGE. ST PRODUCTS WHICH ARE NOT SPECIFIED AS "AUTOMOTIVE GRADE" MAY ONLY BE USED IN AUTOMOTIVE APPLICATIONS AT USER'S OWN RISK.**

Resale of ST products with provisions different from the statements and/or technical features set forth in this document shall immediately void any warranty granted by ST for the ST product or service described herein and shall not create or extend in any manner whatsoever, any liability of ST.

ST and the ST logo are trademarks or registered trademarks of ST in various countries.

Information in this document supersedes and replaces all information previously supplied.

The ST logo is a registered trademark of STMicroelectronics. All other names are the property of their respective owners.

© 2010 STMicroelectronics - All rights reserved

STMicroelectronics group of companies

Australia - Belgium - Brazil - Canada - China - Czech Republic - Finland - France - Germany - Hong Kong - India - Israel - Italy - Japan - Malaysia - Malta - Morocco - Philippines - Singapore - Spain - Sweden - Switzerland - United Kingdom - United States of America

[www.st.com](http://www.st.com)

Компания «Life Electronics» занимается поставками электронных компонентов импортного и отечественного производства от производителей и со складов крупных дистрибьюторов Европы, Америки и Азии.

С конца 2013 года компания активно расширяет линейку поставок компонентов по направлению коаксиальный кабель, кварцевые генераторы и конденсаторы (керамические, пленочные, электролитические), за счёт заключения дистрибьюторских договоров

Мы предлагаем:

- Конкурентоспособные цены и скидки постоянным клиентам.
- Специальные условия для постоянных клиентов.
- Подбор аналогов.
- Поставку компонентов в любых объемах, удовлетворяющих вашим потребностям.
- Приемлемые сроки поставки, возможна ускоренная поставка.
- Доставку товара в любую точку России и стран СНГ.
- Комплексную поставку.
- Работу по проектам и поставку образцов.
- Формирование склада под заказчика.
- Сертификаты соответствия на поставляемую продукцию (по желанию клиента).
- Тестирование поставляемой продукции.
- Поставку компонентов, требующих военную и космическую приемку.
- Входной контроль качества.
- Наличие сертификата ISO.

В составе нашей компании организован Конструкторский отдел, призванный помогать разработчикам, и инженерам.

Конструкторский отдел помогает осуществить:

- Регистрацию проекта у производителя компонентов.
- Техническую поддержку проекта.
- Защиту от снятия компонента с производства.
- Оценку стоимости проекта по компонентам.
- Изготовление тестовой платы монтаж и пусконаладочные работы.



Тел: +7 (812) 336 43 04 (многоканальный)  
Email: [org@lifeelectronics.ru](mailto:org@lifeelectronics.ru)