

LTC6947

Ultralow Noise and Spurious Fractional-N Synthesizer

DESCRIPTION

Demonstration circuit 1846A features the **LTC®6947**, an Ultralow Noise and Spurious Fractional-N Synthesizer.

DC1846A provides 50Ω SMA connectors for the reference frequency (REF+) and the two single-ended RF outputs (RF+ and RF-).

A DC590 USB serial controller board is used for SPI communication with the LTC6947, controlled by the supplied FracNWizard™ software.

Design files for this circuit board are available at <http://www.linear.com/demo>

LT, LT, LTC, LTM, Linear Technology and the Linear logo are registered trademarks and FracNWizard is a trademark of Linear Technology Corporation. All other trademarks are the property of their respective owners.

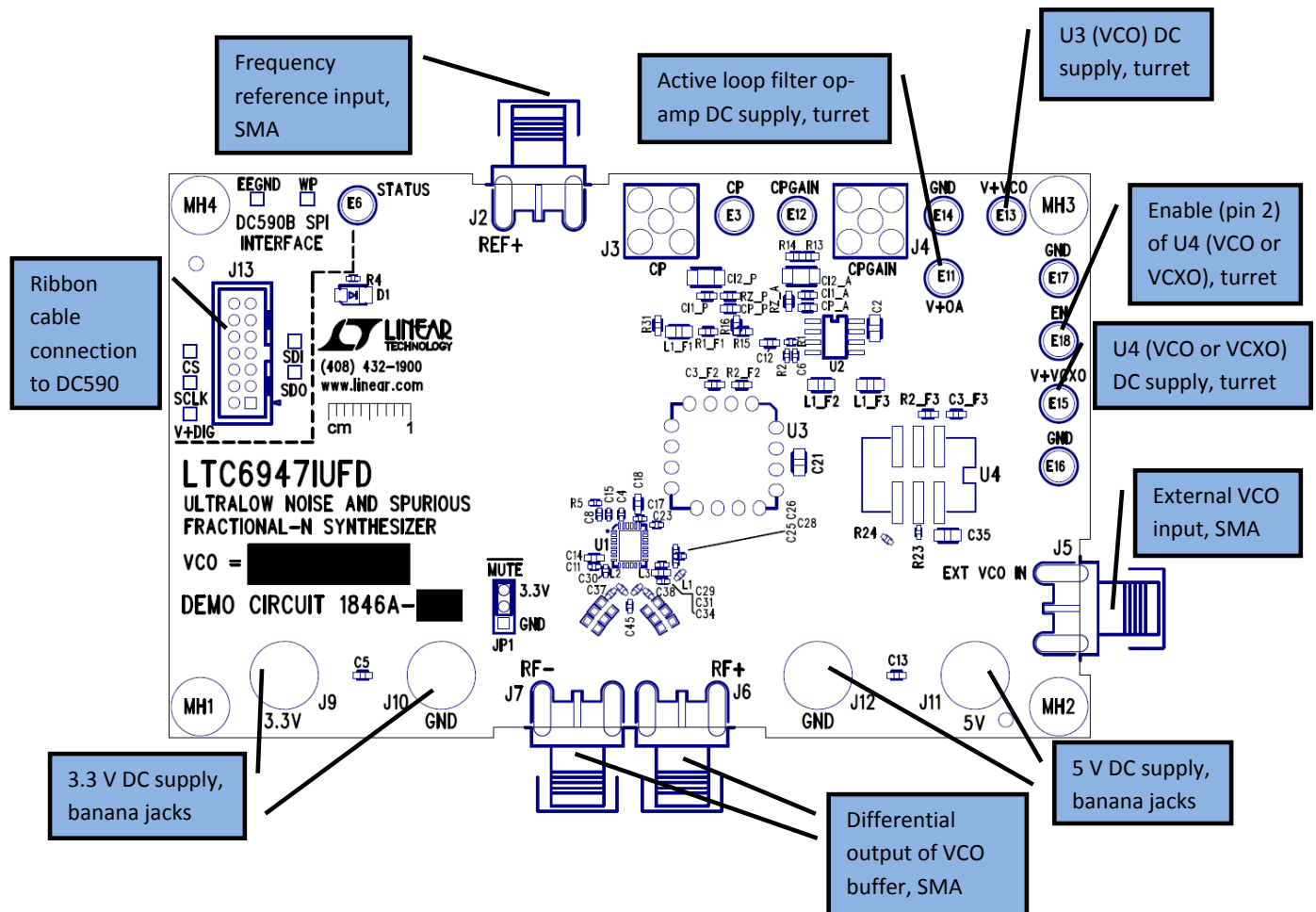

Figure 1. DC1846A Connections

QUICK START PROCEDURE

The DC1846A is easy to set up to evaluate the performance of the LTC6947. Follow the procedure below.

The DC590 and FracNWizard application are required to control the DC1846A through a personal computer (PC).

DC590 Configuration

Place the DC590 jumpers in the following positions (refer to Figure 2):

JP4: EE – Must be in the EN position.

JP5: ISO – ON must be selected.

JP5: SW – ON must be selected.

JP6: VCCIO – 3.3V must be selected. This sets the SPI port to 3.3V operation.

Connect the DC590 to one of your computer's USB ports with the included USB cable.

FracNWizard Installation

The FracNWizard software is used to communicate with the LTC6947 synthesizer. It uses the DC590 to translate between USB and SPI-compatible serial communications formats. It also includes advanced PLL design and simulation capabilities. The following are the FracNWizard system requirements:

- Windows Operating System: Windows XP, Windows 2003 Server, Windows Vista, Windows 7
- Microsoft .NET 3.5 SP1 or later
- Windows Installer 3.1 or later
- Linear Technology's DC590 hardware

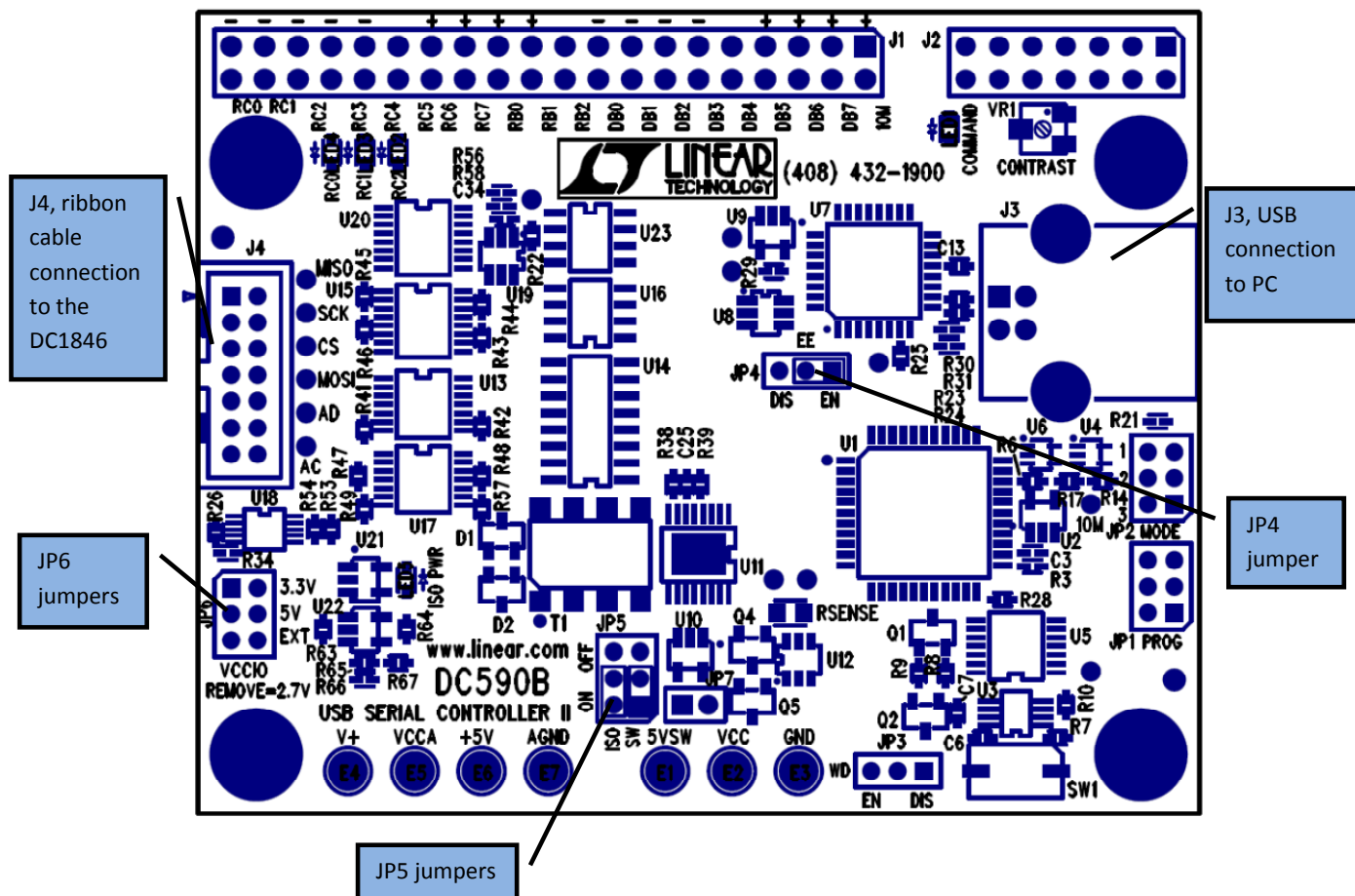

Figure 2. DC590 Jumper and Connector Locations

QUICK START PROCEDURE

Download the FracNWizard setup file at:

www.linear.com/FracNWizard

Run the FracNWizard setup file and follow the instructions given on the screen. The setup file will verify and/or install Microsoft .NET and install the FracNWizard. Refer to the Help menu for software operation.

DC1846A Configuration

1. Connect a 100MHz reference frequency source (at J2) and signal analyzers to RF+ and/or RF- (at J6 and/or J7) using the SMA connectors (see Figure 1 and the Typical DC1846A Requirements and Characteristics table).

Be sure to terminate any unused RF output with 50Ω, or poor spurious performance may result.

2. Choose the MUTE jumper setting:

JP1: GND/3.3V - MUTE position. Select GND to mute the RF output, 3.3V to unmute.

3. Connect the GND, 3.3V, 5V banana jacks and the V+VCO turret to a power supply and apply power (see Figure 1 and the Typical DC1846A Requirements and Characteristics table).

4. Connect the DC590 to the DC1846A with the provided ribbon cable.

5. Run the FracNWizard application.

6. In FracNWizard, click *File -> Load Settings* and point to the "LTC6947_100MHz.fracnset" file.

The red LED on the DC1846A should turn on indicating that the loop is locked at 2415MHz.

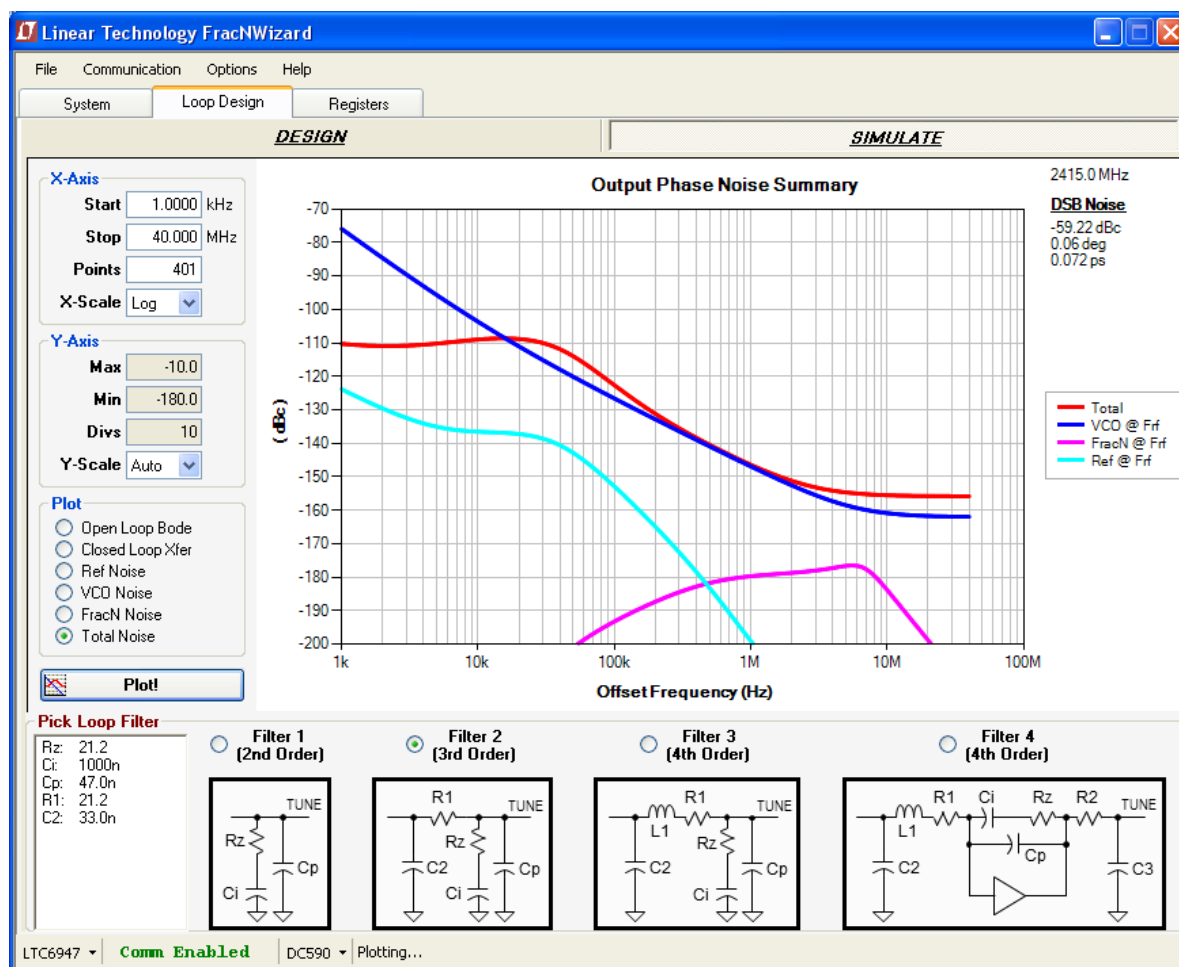

Figure 3. FracNWizard Screenshot

QUICK START PROCEDURE

Troubleshooting

If the red LED does not illuminate, follow the instructions below:

1. Verify that you are able to communicate with the DC1846A. The bottom status line in FracNWizard should read “LTC6947” and “Comm Enabled”. Refer to FracNWizard’s Troubleshoot and Help if not.

2. Verify that the 3.3V, 5V and V+VCO have the correct voltages on them and that the reference frequency is applied to the REF+ SMA input.

If the red LED is on but you cannot detect an RF output, make sure the DC1846A jumper JP1 is at the 3.3V position. Run Help -> Troubleshoot in FracNWizard if the problem is not resolved.

DC1846A RECONFIGURATION

The DC1846A is flexible and allows the use of a variety of VCOs and the choice to employ either an active or passive loop filter. The following covers the hardware reconfiguration of the DC1846A. Refer to FracNWizard’s Help and the LTC6947 data sheet to better understand how to change programmed parameters on the DC1846A.

Installing Different Tunable Devices

The DC1846A permits the use of different tunable oscillators, such as VCOs and VCXOs. There are two different oscillator footprints on the board: U3, which accommodates the popular 0.5 × 0.5 in. package, and U4, which accommodates another common 14mm × 9 mm package with four or six pins. An external connectorized VCO can also

drive the LTC6947 through J5. Table 1 gives options to customize the DC1846’s VCOs. When using an active loop filter, an additional pole is required in the loop filter to limit the op amp’s noise contribution to the VCO phase noise.

Selecting Loop Filter Type

The DC1846A can use either an active or a passive loop filter, depending upon the application. Some VCO tuning voltage ranges are greater than the LTC6947 charge pump voltage range (refer to the LTC6947 data sheet). In such cases, an active loop filter using an op amp can deliver the required tuning voltage. Table 2 summarizes these options. FracNWizard helps determine the component values listed in this table.

Table 1. Oscillator Options

TUNABLE DEVICE	SELECTION COMPONENTS	RESISTOR FOR ADDITIONAL POLE	CAPACITOR FOR ADDITIONAL POLE	POWER	ENABLE PIN OR REMARKS
U3*	C26 ≅ 100pF, depopulate R2_F3, C25 and C28*	R2_F2 = 0Ω for passive loop filter* R2_F2 = 75Ω for active loop filter	C3_F2 = Open for passive loop filter* Pick C3_F2 such that $1/(2\pi \times R2_F2 \times C3_F2) \cong 15 \times$ the loop bandwidth in Hz for active loop filter	Determined by U3 device power supply specification, up to 24V applied to V+VCO turret	
U4	C28 ≅ 100pF, depopulate R2_F2, C25 and C26	R2_F3 = 0Ω for passive loop filter R2_F3 ≅ 75Ω for active loop filter	C3_F3 = Open for passive loop filter Pick C3_F3 such that $1/(2\pi \times R2_F3 \times C3_F3) \cong 15 \times$ the loop bandwidth in Hz for active loop filter	Determined by U4 device power supply specification, up to 24V applied to V+VCXO turret	Use EN turret to control pin 2 of U4 if needed
External	C25 ≅ 100pF, R15 = 0Ω Ohms, depopulate R13, C26 and C28	-	-	-	Selection components are for an active loop filter. Connect the external VCO output to J5. Use CPGAIN to tune the external device.

*These are the default installation options. For the DC1846A-A, U3 is populated with CVC055CC-2328-2536 from Crystek

DC1846A RECONFIGURATION

Table 2. Loop Filter Options

LOOP FILTER TYPE	SELECTION RESISTORS	RZ FROM FRACNWIZARD	CI FROM FRACNWIZARD	CP FROM FRACNWIZARD	POWER	CPINV BOX, SYSTEM TAB IN FRACNWIZARD
Passive	R14 and R16 = 0Ω, depopulate R13 and R15	RZ_P	CI1_P in parallel with CI2_P	CP_P	None	Unchecked
Active	R13 (except when using an external VCO) and R15 = 0Ω, depopulate R14 and R16	RZ_A	CI1_A in parallel with CI2_A	CP_A	Determined by the maximum allowed tune voltage of the populated VCO (U3 or U4), up to 24V applied to V+OA turret	Checked

TYPICAL DC1846A REQUIREMENTS AND CHARACTERISTICS

PARAMETER	INPUT OR OUTPUT	PHYSICAL LOCATION	DETAILS
3.3V Power Supply	Input	J9 and J10 banana jacks	Low noise and spur-free 3.3V, 103mA**
5V Charge Pump Power Supply	Input	J11 and J12 banana jacks	Low noise and spur-free 5V, 22mA**
5V VCO Power Supply	Input	V+VCO turret	Low noise and spur-free 5V, 30mA**
REF+, Reference Frequency	Input	J2 SMA connector	Low noise 100MHz**, 6 to 10dBm into 50Ω, see Note
RF+ and RF-	Two Outputs	J6 and J7 SMA connectors***	2328 to 2536MHz** in 190.7Hz** steps, 0dBm
Loop Bandwidth	–	Set by loop filter component values	30.7kHz**

**These values are for the “DC1846A_100MHz.fracset” file and included VCO.

*** Any unused RF output **must** be terminated with 50Ω, or poor spurious performance may result.

Note: A low noise 100MHz reference frequency, such as the Wenzel 501-04516D OCXO, is recommended. If using a different frequency, make sure to update the Fref and R_DIV boxes under the System tab in FracNWizard so that F_{pd} is still 50MHz. For example, if a 250MHz clock is used, Fref should be changed to 250MHz and R_DIV to 5. Ref BST and FILT under the System tab in FracNWizard might need to be changed if the reference frequency and/or power is different than what is recommended in the table above. More information can be found in the LTC6947 data sheet.

DEMO MANUAL DC1846A

PARTS LIST

ITEM	QTY	REFERENCE	PART DESCRIPTION	MANUFACTURER/PART NUMBER
1	0	CI1_A, C3_F2, C3_F3, CP_A, C14	CAP, 0603	OPT
2	6	CI1_P, C5, C12, C13, C18, C31	CAP, 0603 1.0µF 10% 10V X7R	TAIYO YUDEN, LMK107B7105KA-T
3	0	CI2_P, CI2_A	CAP, 1206	OPT
4	1	CP_P	CAP, 0603 47nF 10% 50V X7R	AVX 06035C473KAT2A
5	3	C1, C19, C33	CAP, 7361 47µF 10% 35V, 7361	AVX TAJV476K035RNJ
6	3	C2, C21, C35	CAP, 0805 0.1µF 10% 50V X7R	AVX 08055C104KAT2A
7	2	C3, C16	CAP, 7343 330µF 10% 10V TANT	AVX TPME337K010R0035
8	9	C4, C6, C11, C30, C36, C39, C41, C43, C44	CAP, 0402 0.1µF 10% 10V X7R	TAIYO YUDEN, LMK105B7104KV-F
9	1	C7	CAP, 7343 47µF 10% 20V TANT	AVX TAJD476K020RNJ
10	2	C8, C15	CAP, 0402 1µF 10% 16V X5R	TDK C1005X5R1C105K
11	4	C17, C23, C34, C45	CAP, 0402 0.01µF 10% 16V X7R	AVX 0402YC103KAT2A
12	1	C2_F1	CAP, 0603 33nF 10% 50V X7R	AVX 06035C333KAT2A
13	0	C25, C28	CAP, 0402	OPT
14	4	C26, C29, C37, C38	CAP, 0402 100pF 10% 16V NPO	AVX 0402YA101KAT2A
15	1	D1	LED, RED	PANASONIC LN1251CTR
16	10	E3, E6, E11-E18	TURRET	MILL-MAX 2501-2-00-80-00-00-07-0
17	1	JP1	HEADER, 3-PIN 2mm	SAMTEC TMM-103-02-L-S
18	4	J2, J5, J6, J7	CONN, SMA 50Ω EDGE-LAUNCH	E.F. JOHNSON, 142-0701-851
19	0	J3, J4	CONN, SMA 50Ω Straight	OPT
20	4	J9, J10, J11, J12	JACK, BANANA	KEYSTONE 575-4
21	1	J13	HEADER, 7 DUAL PIN, 2mm	MOLEX 87831-1420
22	0	L1	IND, 0402	OPT
23	2	L2, L3	IND, 0402 68nH 5%	COILCRAFT 0402HPH-68NXJLW
24	1	L1_F1	RES, 0805, 0Ω JUMPER	VISHAY CRCW08050000Z0EA
25	0	L1_F2, L1_F3	IND, 0805	OPT
26	2	R1_F1, RZ_P	RES, 0603 21Ω 1% 1/10W	VISHAY CRCW060321R0FKED
27	5	R1, R2, R11, R20, R26	RES, 0402 4.99kΩ 1% 1/16W	VISHAY CRCW04024K99FKED
28	1	R4	RES, 0402 330Ω 1% 1/16W	NIC NRC04F3300TRF
29	1	R5	RES, 0402 51.1Ω 1% 1/10W	VISHAY CRCW040251R1FKED
30	4	R7, R8, R18, R19	RES, 0402 200kΩ 1% 1/16W	VISHAY CRCW0402200KFKED
31	4	R9, R14, R16, R2_F2	RES, 0603 0Ω JUMPER	VISHAY CRCW06030000Z0EA
32	3	R12, R21, R22	RES, 0402 100Ω 5% 1/16W	VISHAY CRCW0402101RJKED
33	0	R13, R15, R2_F3, RZ_A, R31	RES, 0603	OPT
34	0	R23, R24	RES, 0402	OPT
35	5	R25, R27, R28, R29, R30	RES, 0402 0Ω JUMPER	VISHAY CRCW04020000Z0EA
36	1	U1	IC, QFN28IUFD-4X5	LINEAR TECH. LTC6947IUFD
37	1	U2	IC, LOW NOISE AMP, SO8	LINEAR TECH. LT1678IS8#PBF
38	1	U3	IC, VCO	CRYSTEK, CVC055CC-2328-2536
39	0	U4	IC, CRYSTAL OSCILLATOR	OPT
40	2	U5, U10	IC, DUAL BUFFER, SC70	FAIRCHILD SEMI NC7WZ17P6X
41	1	U8	I.C., Serial EEPROM, TSSOP8	MICROCHIP, 24LC025-1 /ST
42	1	U11	IC, DUAL TRANSCEIVER, SOT363	NXP 74LVC1T45GW
43	1	SHUNT ON JP1 (2&3)	SHUNT, 2mm CTRS	SAMTEC 2SN-BK-G

SCHEMATIC DIAGRAM

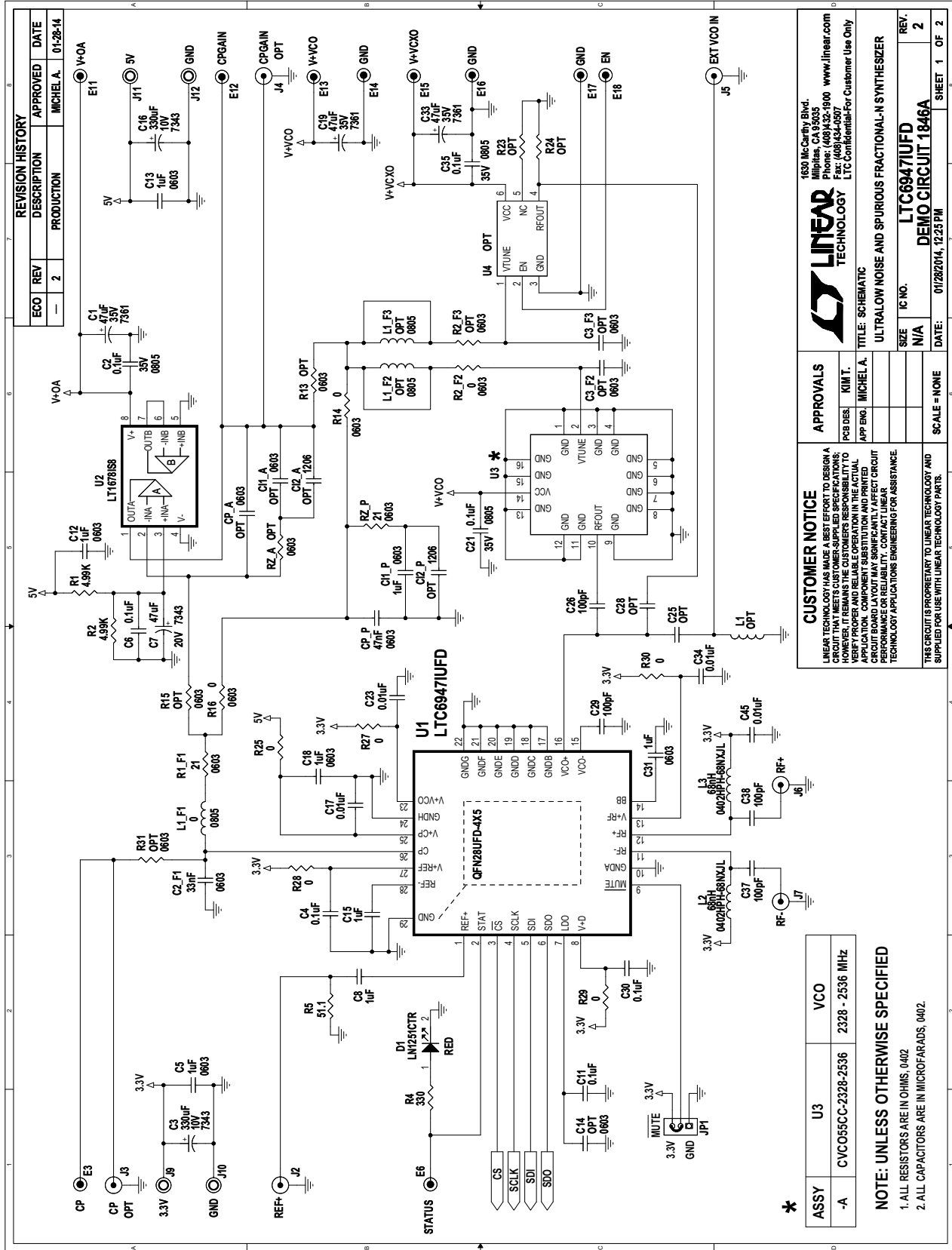

REVISION HISTORY

ECO	REV	DESCRIPTION	APPROVED	DATE
—	2	PRODUCTION	MICHEL A.	01-28-14

LINEAR TECHNOLOGY
1630 McCarthy Blvd.
Milpitas, CA 95035
Phone: (408)321-9100 www.linear.com
Fax: (408)321-4507 LTC Confidential-For Customer Use Only

APPROVALS

PCB DES.	UNIT.
APP ENG.	MICHEL A.

TITLE: SCHEMATIC
ULTRALOW NOISE AND SPURIOUS FRACTIONAL-N SYNTHESIZER

SIZE	IC NO.	REV.
N/A	LTC6947IUFD	2

DATE: 01/28/2014, 12:23 PM
SHEET 1 OF 2

CUSTOMER NOTICE

LINEAR TECHNOLOGY HAS MADE A BEST EFFORT TO DESIGN A CIRCUIT THAT MEETS CUSTOMER-SUPPLIED SPECIFICATIONS. CUSTOMERS ARE RESPONSIBLE TO VERIFY PROPER AND RELIABLE OPERATION IN THE ACTUAL APPLICATION. COMPONENT SUBSTITUTION AND PRINTED CIRCUIT BOARD LAYOUT MAY SIGNIFICANTLY AFFECT CIRCUIT PERFORMANCE OR RELIABILITY. CONTACT LINEAR TECHNOLOGY APPLICATIONS ENGINEERING FOR ASSISTANCE.

THIS CIRCUIT IS PROPRIETARY TO LINEAR TECHNOLOGY AND SUPPLIED FOR USE WITH LINEAR TECHNOLOGY PARTS.

NOTE: UNLESS OTHERWISE SPECIFIED

- ALL RESISTORS ARE IN OHMS, 0402
- ALL CAPACITORS ARE IN MICROFARADS, 0402.

ASSY	U3	VCO
-A	CVC055C-2328-2536	2328 - 2536 MHz

LAYOUT TOP LAYER

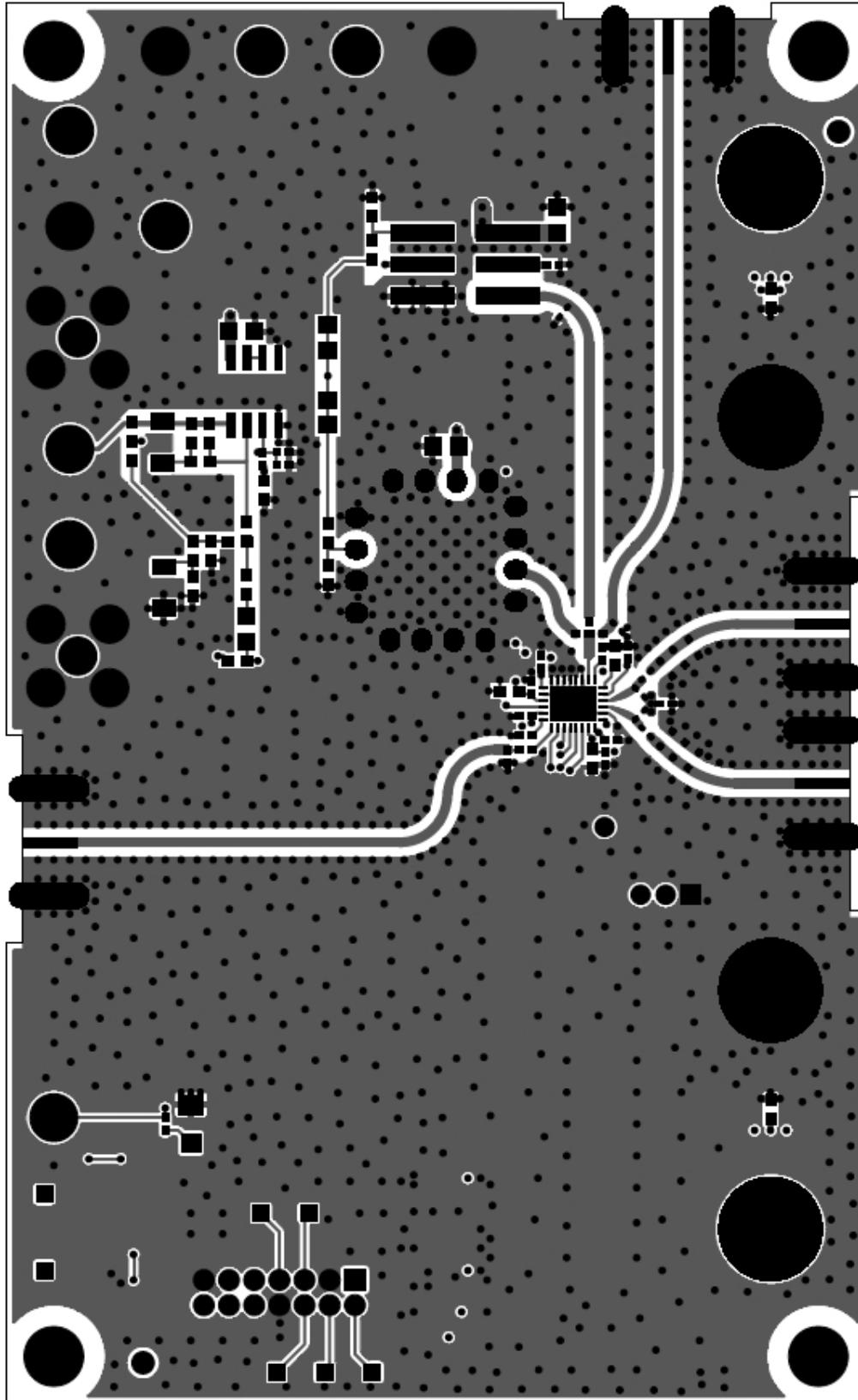

dc1846af

DEMO MANUAL DC1846A

DEMONSTRATION BOARD IMPORTANT NOTICE

Linear Technology Corporation (LTC) provides the enclosed product(s) under the following **AS IS** conditions:

This demonstration board (DEMO BOARD) kit being sold or provided by Linear Technology is intended for use for **ENGINEERING DEVELOPMENT OR EVALUATION PURPOSES ONLY** and is not provided by LTC for commercial use. As such, the DEMO BOARD herein may not be complete in terms of required design-, marketing-, and/or manufacturing-related protective considerations, including but not limited to product safety measures typically found in finished commercial goods. As a prototype, this product does not fall within the scope of the European Union directive on electromagnetic compatibility and therefore may or may not meet the technical requirements of the directive, or other regulations.

If this evaluation kit does not meet the specifications recited in the DEMO BOARD manual the kit may be returned within 30 days from the date of delivery for a full refund. **THE FOREGOING WARRANTY IS THE EXCLUSIVE WARRANTY MADE BY THE SELLER TO BUYER AND IS IN LIEU OF ALL OTHER WARRANTIES, EXPRESSED, IMPLIED, OR STATUTORY, INCLUDING ANY WARRANTY OF MERCHANTABILITY OR FITNESS FOR ANY PARTICULAR PURPOSE. EXCEPT TO THE EXTENT OF THIS INDEMNITY, NEITHER PARTY SHALL BE LIABLE TO THE OTHER FOR ANY INDIRECT, SPECIAL, INCIDENTAL, OR CONSEQUENTIAL DAMAGES.**

The user assumes all responsibility and liability for proper and safe handling of the goods. Further, the user releases LTC from all claims arising from the handling or use of the goods. Due to the open construction of the product, it is the user's responsibility to take any and all appropriate precautions with regard to electrostatic discharge. Also be aware that the products herein may not be regulatory compliant or agency certified (FCC, UL, CE, etc.).

No License is granted under any patent right or other intellectual property whatsoever. **LTC assumes no liability for applications assistance, customer product design, software performance, or infringement of patents or any other intellectual property rights of any kind.**

LTC currently services a variety of customers for products around the world, and therefore this transaction **is not exclusive**.

Please read the DEMO BOARD manual prior to handling the product. Persons handling this product must have electronics training and observe good laboratory practice standards. **Common sense is encouraged.**

This notice contains important safety information about temperatures and voltages. For further safety concerns, please contact a LTC application engineer.

Mailing Address:

Linear Technology
1630 McCarthy Blvd.
Milpitas, CA 95035

Copyright © 2004, Linear Technology Corporation

Компания «Life Electronics» занимается поставками электронных компонентов импортного и отечественного производства от производителей и со складов крупных дистрибьюторов Европы, Америки и Азии.

С конца 2013 года компания активно расширяет линейку поставок компонентов по направлению коаксиальный кабель, кварцевые генераторы и конденсаторы (керамические, пленочные, электролитические), за счёт заключения дистрибьюторских договоров

Мы предлагаем:

- Конкурентоспособные цены и скидки постоянным клиентам.
- Специальные условия для постоянных клиентов.
- Подбор аналогов.
- Поставку компонентов в любых объемах, удовлетворяющих вашим потребностям.
- Приемлемые сроки поставки, возможна ускоренная поставка.
- Доставку товара в любую точку России и стран СНГ.
- Комплексную поставку.
- Работу по проектам и поставку образцов.
- Формирование склада под заказчика.
- Сертификаты соответствия на поставляемую продукцию (по желанию клиента).
- Тестирование поставляемой продукции.
- Поставку компонентов, требующих военную и космическую приемку.
- Входной контроль качества.
- Наличие сертификата ISO.

В составе нашей компании организован Конструкторский отдел, призванный помогать разработчикам, и инженерам.

Конструкторский отдел помогает осуществить:

- Регистрацию проекта у производителя компонентов.
- Техническую поддержку проекта.
- Защиту от снятия компонента с производства.
- Оценку стоимости проекта по компонентам.
- Изготовление тестовой платы монтаж и пусконаладочные работы.



Тел: +7 (812) 336 43 04 (многоканальный)

Email: org@lifeelectronics.ru