

## 44 V, 5.5 A, quad power half-bridge

Datasheet - production data

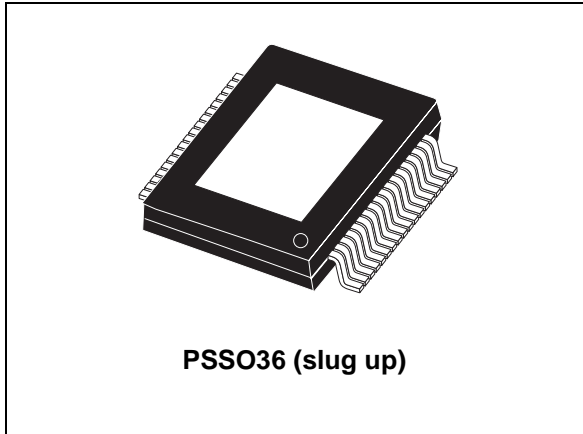

### Description

The STA510A is a monolithic, quad, half-bridge stage in multipower BCD technology. The device can be used as dual-bridge or reconfigured, by connecting the CONFIG pin to the VDD pin, as single-bridge with double current capability, or as half-bridge (binary mode) with half current capability.

The device is particularly designed to make the output stage of a stereo all-digital high-efficiency (DDX) amplifier, which employs a pulse-width modulator driver. The STA510A is capable of delivering an output power of 50 W into 3 Ω loads with THD = 10% and  $V_{CC} = 36$  V. In single BTL configuration the device can deliver 200 W into a 3 Ω load with THD = 10% and  $V_{CC} = 36$  V.

The input pins have a threshold proportional to  $V_L$  pin voltage.

### Features

- Multipower BCD technology
- Minimum input/output pulse width distortion
- 150 mΩ  $R_{DS(on)}$  complementary DMOS output stage
- CMOS compatible logic inputs
- Thermal protection
- Thermal warning output
- Undervoltage protection
- Short-circuit protection

**Table 1. Device summary**

Order code	Operating temp. range	Package	Packing
STA510A13TR	0° to 70° C	PSSO36 (slug up)	Tape and reel

# Contents

- 1      Audio application circuit ..... 3**
- 2      Pin description ..... 4**
- 3      Electrical specifications ..... 6**
  - 3.1 Absolute maximum ratings ..... 6
  - 3.2 Recommended operating conditions ..... 6
  - 3.3 Thermal data ..... 6
  - 3.4 Electrical specifications ..... 7
- 4      Technical information ..... 11**
  - 4.1 Logic interface and decode .....11
  - 4.2 Protection circuitry ..... 12
  - 4.3 Power outputs ..... 12
  - 4.4 Parallel output / high current operation ..... 12
  - 4.5 Output filtering ..... 12
  - 4.6 Application circuits ..... 13
- 5      Package information ..... 15**
- 6      Revision history ..... 17**

# 1 Audio application circuit

Figure 1. TAudio application circuit (dual BTL)

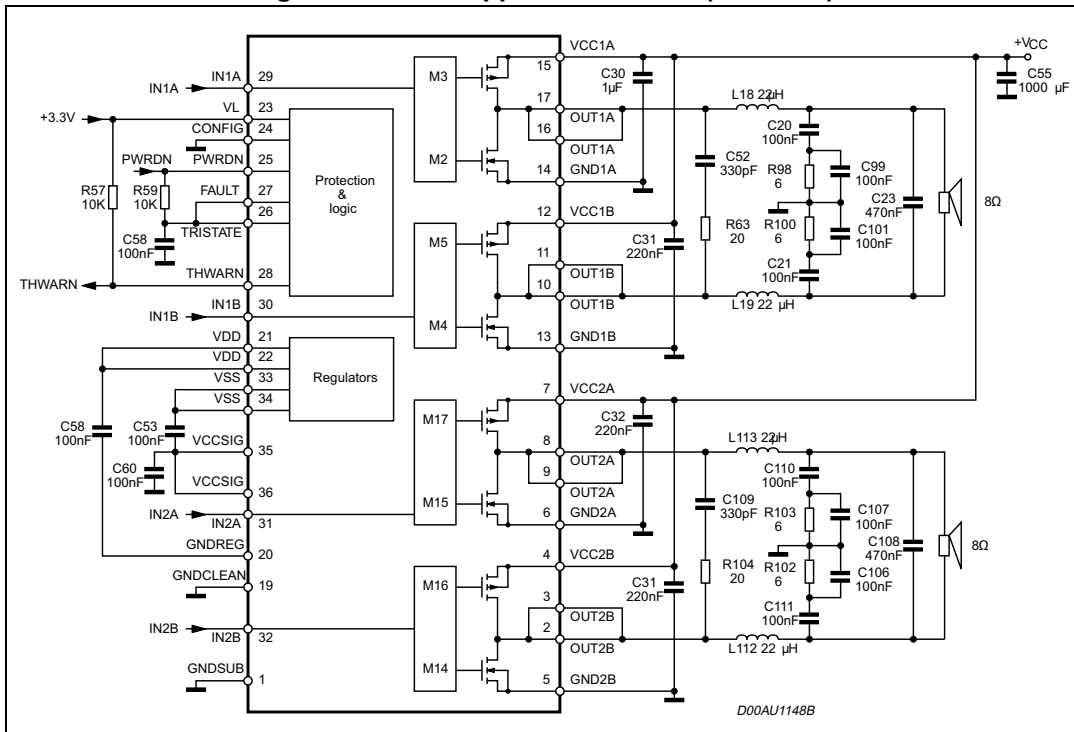

## 2 Pin description

Figure 2. Pin connections (top view)

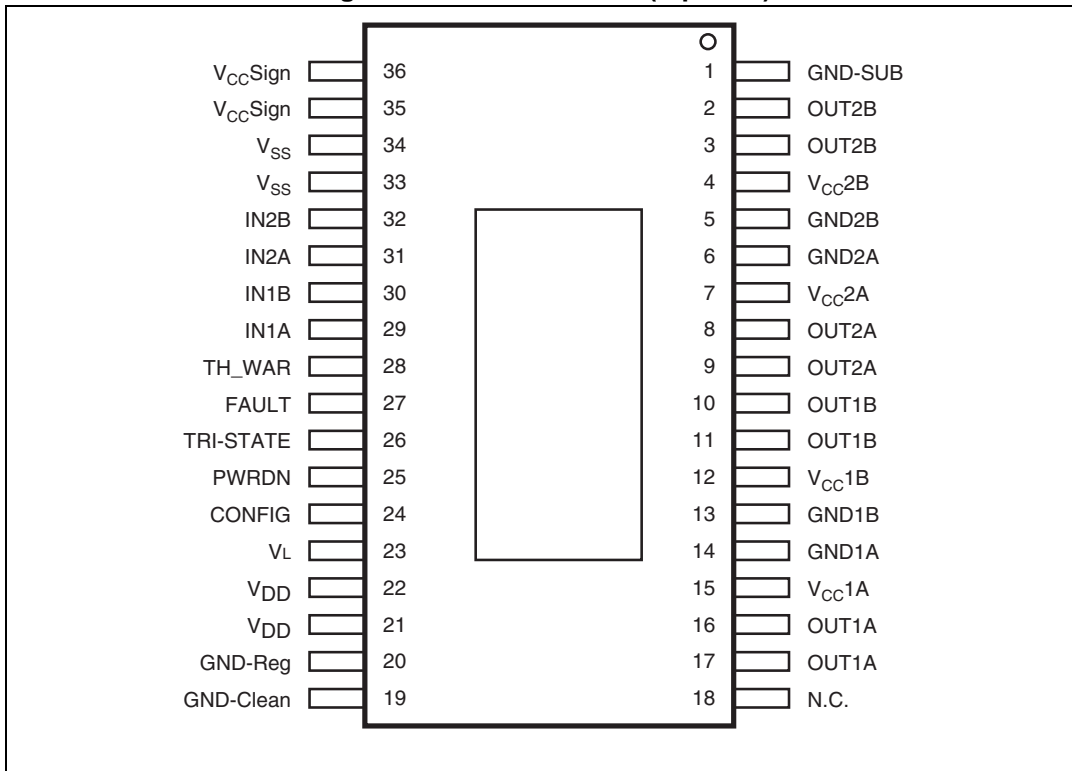

Table 2. Pin list

Pin	Name	Description
1	GND-SUB	Substrate ground
2, 3	OUT2B	Output half-bridge 2B
4	V <sub>CC</sub> 2B	Positive supply
5	GND2B	Negative supply
6	GND2A	Negative supply
7	V <sub>CC</sub> 2A	Positive supply
8, 9	OUT2A	Output half-bridge 2A
10, 11	OUT1B	Output half-bridge 1B
12	V <sub>CC</sub> 1B	Positive supply
13	GND1B	Negative supply
14	GND1A	Negative supply
15	V <sub>CC</sub> 1A	Positive supply
16, 17	OUT1A	Output half-bridge 1A
18	NC	Not connected

Table 2. Pin list (continued)

Pin	Name	Description
19	GND-clean	Logical ground
20	GND-Reg	Ground for regulator $V_{DD}$
21, 22	$V_{DD}$	5-V regulator referred to ground
23	$V_L$	High logical state setting voltage
24	CONFIG	Configuration 0: normal operation 1: single BTL (mono) mode, join the pins OUT1A to OUT1B and OUT2A to OUT2B (if IN1A is joined to IN1B and IN2A to IN2B)
25	PWRDN	Standby (power down): 0: low power consumption mode 1: normal operation
26	TRI-STATE	High impedance control: 0: all power amplifiers in high-impedance state 1: normal operation
27	FAULT <sup>(1)</sup>	Fault advisor: 0: fault detected (short circuit or thermal) 1: normal operation
28	TH-WAR	Thermal warning advisor: 0: junction temperature = 130 °C 1: normal operation
29	IN1A	Input of half-bridge 1A
30	IN1B	Input of half-bridge 1B
31	IN2A	Input of half-bridge 2A
32	IN2B	Input of half-bridge 2B
33, 34	$V_{SS}$	5-V regulator referred to $+V_{CC}$
35, 36	VCCSIGN	Signal positive supply
-	EP	Exposed pad up

1. The pin is open collector. To have a high logic value it needs to be pulled up by a resistor.

## 3 Electrical specifications

### 3.1 Absolute maximum ratings

Table 3. Absolute maximum ratings

Symbol	Parameter	Value	Unit
$V_{CC}$	DC supply voltage (pin 4, 7, 12, 15)	44	V
$V_{max}$	Maximum voltage on pins 23 to 32	5.5	V
$P_{tot}$	Power dissipation ( $T_{case} = 70\text{ °C}$ )	21	W
$T_{op}$	Operating temperature range	90	°C
$T_{stg}, T_j$	Storage and junction temperature	-40 to 150	°C

### 3.2 Recommended operating conditions

Table 4. Recommended operating conditions<sup>(1)</sup>

Symbol	Parameter	Min.	Typ.	Max.	Unit
$V_{CC}$	DC supply voltage	10		39.0	V
$V_L$	Input logic reference	2.7	3.3	5.0	V
$T_{amb}$	Ambient temperature	0		70	°C

1. Performance not guaranteed beyond recommended operating conditions.

### 3.3 Thermal data

The power dissipated within the device depends primarily on the supply voltage, load impedance and output modulation level. The PowerSO36 package of the STA510A includes an exposed pad or slug on the top of the device to provide a direct thermal path from the die to the heatsink.

Table 5. Thermal data

Symbol	Parameter	Min.	Typ.	Max.	Unit
$T_{j-case}$	Thermal resistance junction to case (thermal pad)		1	2.5	°C/W
$T_{jSD}$	Thermal shut-down junction temperature		150		°C
$T_{warn}$	Thermal warning temperature		130		°C
$t_{hSD}$	Thermal shutdown hysteresis		25		°C

### 3.4 Electrical specifications

The results in [Table 6](#) below are given for the conditions:  $V_L = 3.3\text{ V}$ ,  $V_{CC} = 36\text{ V}$ ,  $R_L = 8\ \Omega$ ,  $f_{sw} = 384\text{ kHz}$  and  $T_{amb} = 25\text{ °C}$  unless otherwise specified. See also [Figure 3](#).

**Table 6. Electrical specifications**

Symbol	Parameter	Conditions	Min.	Typ.	Max.	Unit
$R_{dsON}$	Power P-channel/N-channel MOSFET $R_{DS(on)}$	$I_d = 1\text{ A}$		150	200	m $\Omega$
$I_{dss}$	Power P-channel/N-channel leakage current				100	$\mu\text{A}$
$g_N$	Power P-channel $R_{DS(on)}$ matching	$I_d = 1\text{ A}$	95			%
$g_P$	Power N-channel $R_{DS(on)}$ matching	$I_d = 1\text{ A}$	95			%
$Dt_s$	Low current deadtime (static)	See test circuit <a href="#">Figure 3</a>		10	20	ns
$Dt_d$	High current deadtime (dynamic)	$L = 22\ \mu\text{H}$ , $C = 470\text{ nF}$ , $R_L = 8\ \Omega$ , $I_d = 3\text{ A}$ , see test circuit <a href="#">Figure 5</a>			50	ns
$t_{dON}$	Turn-on delay time	Resistive load, $V_{CC} = 30\text{ V}$			100	ns
$t_{dOFF}$	Turn-off delay time	Resistive load, $V_{CC} = 30\text{ V}$			100	ns
$t_r$	Rise time	Resistive load, as <a href="#">Figure 3</a>			25	ns
$t_f$	Fall time	Resistive load, as <a href="#">Figure 3</a>			25	ns
$V_{IN-High}$	High level input voltage				$V_L/2 + 300\text{ mV}$	V
$V_{IN-Low}$	Low level input voltage		$V_L/2 - 300\text{ mV}$			V
$I_{IN-H}$	High level input current	Pin voltage = $V_L$		1		$\mu\text{A}$
$I_{IN-L}$	Low level input current	Pin voltage = $0.3\text{ V}$		1		$\mu\text{A}$
$I_{PWRDN-H}$	High level PWRDN pin input current	$V_L = 3.3\text{ V}$		35		$\mu\text{A}$
$V_{Low}$	Low logical state voltage (pins PWRDN, TRISTATE)	$V_L = 2.7\text{ V}$			0.70	V
		$V_L = 3.3\text{ V}$			0.80	
		$V_L = 5.0\text{ V}$			0.85	
$V_{High}$	High logical state voltage (pins PWRDN, TRISTATE)	$V_L = 2.7\text{ V}$	1.50			V
		$V_L = 3.3\text{ V}$	1.7			V
		$V_L = 5.0\text{ V}$	1.85			V
$I_{VCC-PWRDN}$	Supply current from $V_{CC}$ in power down	PWRDN = 0			3	mA
$I_{FAULT}$	Output current pins FAULT -TH-WARN when FAULT CONDITIONS	$V_{PIN} = 3.3\text{ V}$		1		mA
$I_{VCC-hiz}$	Supply current from $V_{CC}$ in tri-state	$V_{CC} = 30\text{ V}$ , Pin TRI-STATE = 0		22		mA

Table 6. Electrical specifications (continued)

Symbol	Parameter	Conditions	Min.	Typ.	Max.	Unit
$I_{VCC}$	Supply current from $V_{CC}$ in operation (both channel switching)	$V_{CC} = 30\text{ V}$ , input pulse width duty cycle = 50%, switching frequency = 384 kHz, no LC filters;		70		mA
$I_{SCP}$	Short-circuit current limit		5.5	6		A
$V_{UV}$	Undervoltage protection threshold			7		V
$t_{pw\_min}$	Output minimum pulse width	No load	25		40	ns
ESD	ESD maximum withstanding voltage range, test condition CDF-AEC-Q100-002-"Human Body Model"		± 1500			V



Table 7. Logic truth table

TRI-STATE	INxA	INxB	Q1	Q2	Q3	Q4	Output mode
0	x	x	OFF	OFF	OFF	OFF	Hi-Z
1	0	0	OFF	OFF	ON	ON	DUMP
1	0	1	OFF	ON	ON	OFF	NEGATIVE
1	1	0	ON	OFF	OFF	ON	POSITIVE
1	1	1	ON	ON	OFF	OFF	Not used

Figure 3. Test circuit for low current deadtime for single-ended applications

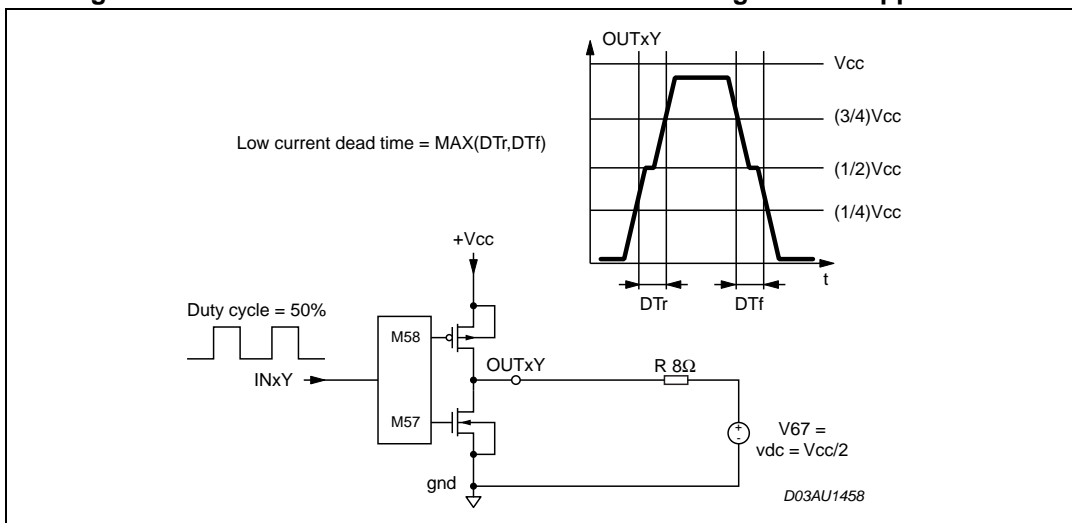

Figure 4. Test circuit for high current deadtime for bridge applications

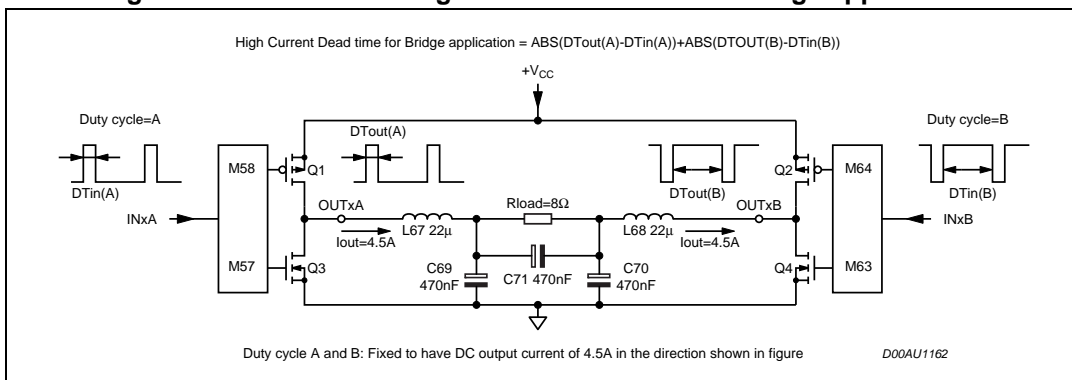
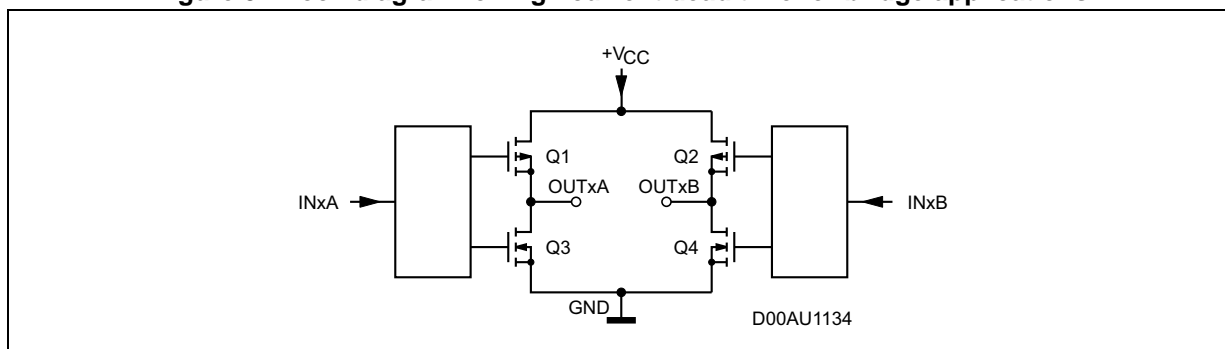

Figure 5. Block diagram for high current dead time for bridge applications



## 4 Technical information

The STA510A is a dual channel H-bridge that is able to deliver 100 W per channel (into  $R_L = 6 \Omega$  with THD = 10% and  $V_{CC} = 36 V$ ) of audio output power very efficiently. It operates in conjunction with a pulse-width modulator driver such as the STA321 or STA309A.

The STA510A converts ternary-, phase-shift- or binary-controlled PWM signals into audio power at the load. It includes a logic interface, integrated bridge drivers, high efficiency MOSFET outputs and thermal and short-circuit protection circuitry. In differential mode (ternary, phase-shift or binary differential), two logic level signals per channel are used to control high-speed MOSFET switches to connect the speaker load to the input supply or to ground in a bridge configuration, according to the damped ternary modulation operation.

In binary mode, both full bridge and half bridge modes are supported. The STA510A includes overcurrent and thermal protection as well as an undervoltage lockout with automatic recovery. A thermal warning status is also provided.

**Figure 6. Block diagram of full-bridge DDX® or binary mode**

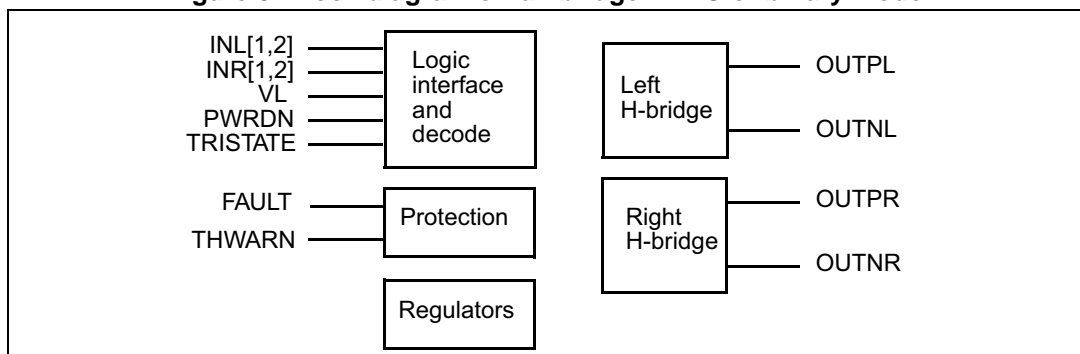

**Figure 7. Block diagram of f binary half-bridge mode**

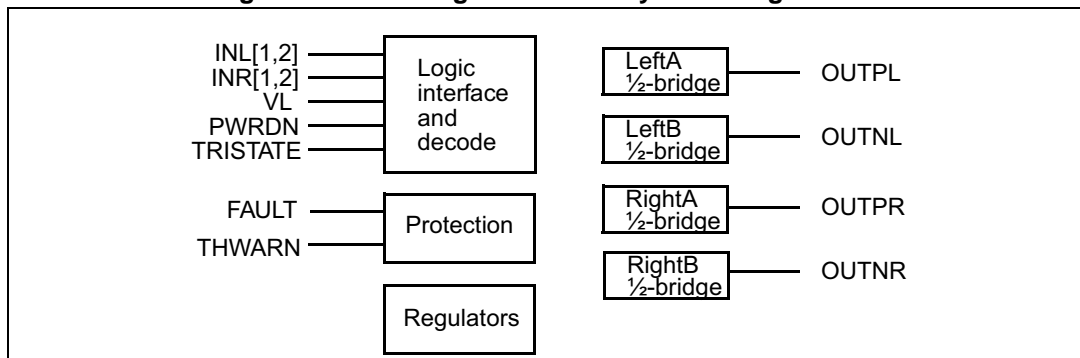

### 4.1 Logic interface and decode

The STA510A power outputs are controlled using one or two logic-level timing signals. In order to provide a proper logic interface, the VL input must operate at the same voltage as the DDX control logic supply.

## 4.2 Protection circuitry

The STA510A includes protection circuitry for overcurrent and thermal overload conditions. A thermal warning pin (THWARN, pin 28, open drain MOSFET) is activated low when the IC temperature exceeds 130 °C, just in advance of thermal shutdown. When a fault condition is detected an internal fault signal immediately disables the output power MOSFETs, placing both H-bridges in a high-impedance state. At the same time the open-drain MOSFET of pin FAULT (pin 27) is switched on.

There are two possible modes subsequent to activating a fault.

- **Shutdown mode:** with pins FAULT (with pull-up resistor) and TRISTATE separate, an activated fault disables the device, signalling a low at pin FAULT output. The device may subsequently be reset to normal operation by toggling pin TRISTATE from high to low to high using an external logic signal.
- **Automatic recovery mode:** This is shown in the applications circuits below where pins FAULT and TRISTATE are connected together to a time-constant circuit (R59 and C58). An activated fault forces a reset on pin TRISTATE causing normal operation to resume following a delay determined by the time constant of the circuit. If the fault condition persists, the circuit operation repeats until the fault condition is cleared. An increase in the time constant of the circuit produces a longer recovery interval. Care must be taken in the overall system design not to exceed the protection thresholds under normal operation.

## 4.3 Power outputs

The STA510A power and output pins are duplicated to provide a low-impedance path for the device bridged outputs. All duplicate power, ground and output pins must be connected for proper operation.

The PWRDN or TRISTATE pin should be used to set all power MOSFETs to the high-impedance state during power-up until the logic power supply, VL, has settled.

## 4.4 Parallel output / high current operation

When using the DDX mode output, the STA510A outputs can be connected in parallel in order to increase the output current capability to a load. In this configuration the STA510A can provide up to 200 W into a 3-Ω load.

This mode of operation is enabled with the pin CONFIG (pin 24) connected to pin VDD. The inputs are joined so that IN1A = IN1B, IN2A = IN2B and similarly the outputs OUT1A = OUT1B, OUT2A = OUT2B as shown in [Figure 9](#).

## 4.5 Output filtering

A passive 2<sup>nd</sup>-order filter is used on the STA510A power outputs to reconstruct the analog audio signal. System performance can be significantly affected by the output filter design and choice of passive components. A filter design for 6- or 8-Ω loads is shown in the application circuit of [Figure 8](#), and for 4-Ω loads in [Figure 9](#) and [Figure 10](#).

### 4.6 Application circuits

Figure 8. Typical stereo full bridge configuration for up to 2x 100 W

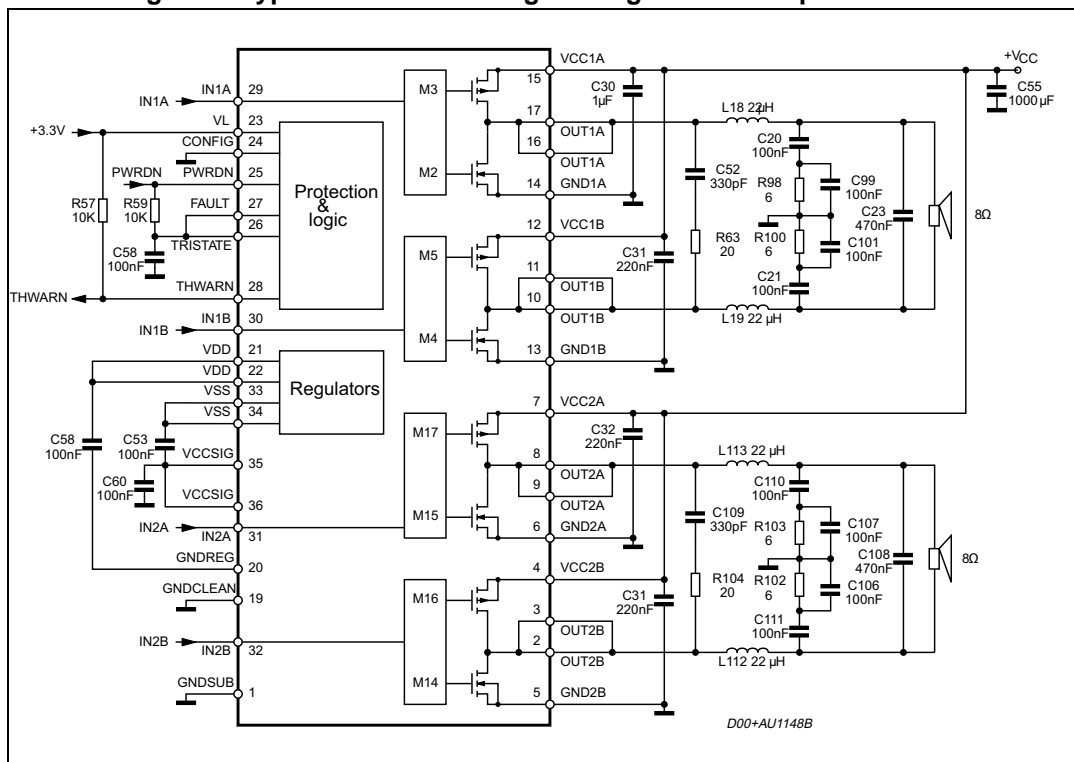

Figure 9. Typical single BTL configuration for up to 180 W

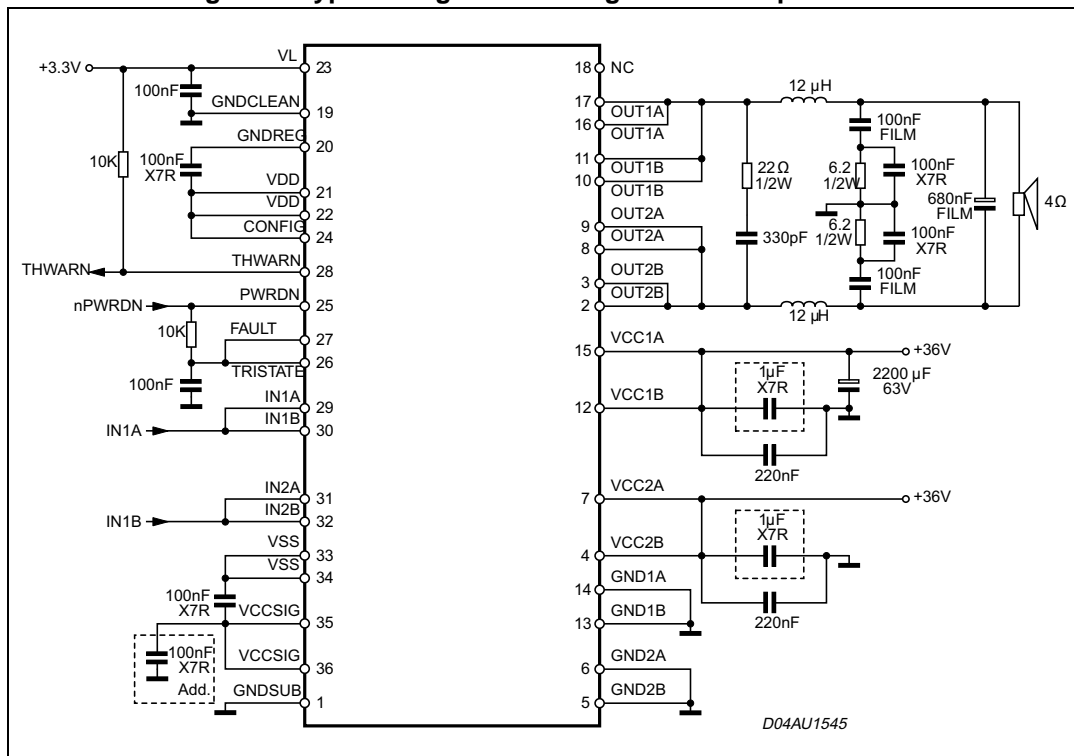
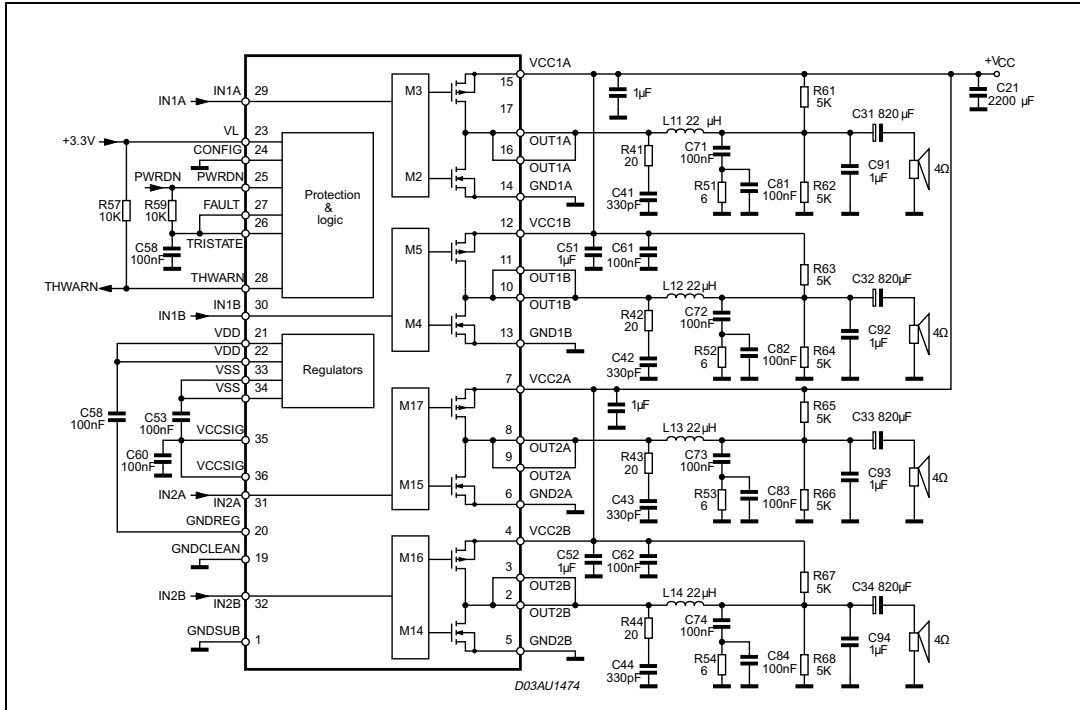

Figure 10. Typical quad half-bridge configuration for up to 4x 50 W



Note: In the above three circuits a PWM modulator as driver is needed.  
 The power estimations were made using the STA321+STA510A demo board. The peak power duration is for  $t \leq 1$  s.

## 5 Package information

In order to meet environmental requirements, ST offers these devices in different grades of ECOPACK<sup>®</sup> packages, depending on their level of environmental compliance. ECOPACK<sup>®</sup> specifications, grade definitions and product status are available at: [www.st.com](http://www.st.com). ECOPACK<sup>®</sup> is an ST trademark.

Figure 11. PSSO36 (slug up) package outline

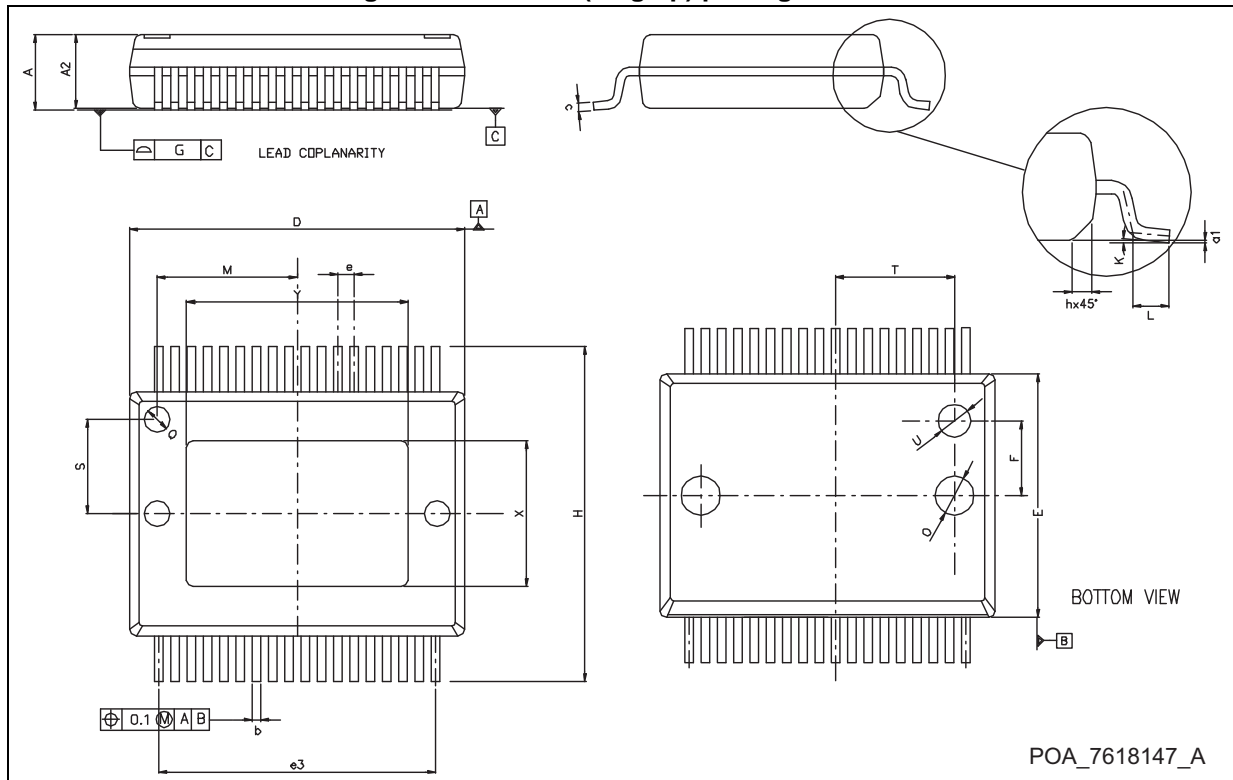

Table 8. PSSO36 (slug up) mechanical data

Dim.	mm			inches		
	Min.	Typ.	Max.	Min.	Typ.	Max.
A	2.15		2.47	0.084		0.097
A2	2.15		2.40	0.084		0.094
a1	0		0.075	0		0.003
b	0.18		0.36	0.007		0.014
c	0.23		0.32	0.009		0.012
D <sup>(1)</sup>	10.10		10.50	0.398		0.413
E <sup>(1)</sup>	7.4		7.6	0.291		0.299
e		0.50			0.020	
e3		8.50			0.035	
F		2.3			0.090	
G			0.10			0.004
G1			0.06			0.002
H	10.10		10.50	0.398		0.413
h			0.40			0.016
L	0.55		0.85	0.022		0.033
M		4.3			0.169	
N	10° (max.)			10° (max.)		
O		1.2			0.047	
Q		0.8			0.031	
S		2.9			0.114	
T		3.65			0.144	
U		1.0			0.039	
X	4.10		4.70	0.161		0.185
Y	6.50		7.10	0.256		0.279

1. "D and E" do not include mold flash or protrusion. Mold flash or protrusion shall not exceed 0.15 mm (0.006").



## 6 Revision history

**Table 9. Document revision history**

<b>Date</b>	<b>Revision</b>	<b>Changes</b>
13-Oct-2004	1	Initial release.
11-Mar-2010	2	Updated description and applications circuits
15-Jan-2019	3	Removed the order code STA510A from the device summary table in cover page.

**IMPORTANT NOTICE – PLEASE READ CAREFULLY**

STMicroelectronics NV and its subsidiaries ("ST") reserve the right to make changes, corrections, enhancements, modifications, and improvements to ST products and/or to this document at any time without notice. Purchasers should obtain the latest relevant information on ST products before placing orders. ST products are sold pursuant to ST's terms and conditions of sale in place at the time of order acknowledgement.

Purchasers are solely responsible for the choice, selection, and use of ST products and ST assumes no liability for application assistance or the design of Purchasers' products.

No license, express or implied, to any intellectual property right is granted by ST herein.

Resale of ST products with provisions different from the information set forth herein shall void any warranty granted by ST for such product.

ST and the ST logo are trademarks of ST. All other product or service names are the property of their respective owners.

Information in this document supersedes and replaces information previously supplied in any prior versions of this document.

© 2019 STMicroelectronics – All rights reserved

Компания «Life Electronics» занимается поставками электронных компонентов импортного и отечественного производства от производителей и со складов крупных дистрибьюторов Европы, Америки и Азии.

С конца 2013 года компания активно расширяет линейку поставок компонентов по направлению коаксиальный кабель, кварцевые генераторы и конденсаторы (керамические, пленочные, электролитические), за счёт заключения дистрибьюторских договоров

Мы предлагаем:

- Конкурентоспособные цены и скидки постоянным клиентам.
- Специальные условия для постоянных клиентов.
- Подбор аналогов.
- Поставку компонентов в любых объемах, удовлетворяющих вашим потребностям.
- Приемлемые сроки поставки, возможна ускоренная поставка.
- Доставку товара в любую точку России и стран СНГ.
- Комплексную поставку.
- Работу по проектам и поставку образцов.
- Формирование склада под заказчика.
- Сертификаты соответствия на поставляемую продукцию (по желанию клиента).
- Тестирование поставляемой продукции.
- Поставку компонентов, требующих военную и космическую приемку.
- Входной контроль качества.
- Наличие сертификата ISO.

В составе нашей компании организован Конструкторский отдел, призванный помогать разработчикам, и инженерам.

Конструкторский отдел помогает осуществить:

- Регистрацию проекта у производителя компонентов.
- Техническую поддержку проекта.
- Защиту от снятия компонента с производства.
- Оценку стоимости проекта по компонентам.
- Изготовление тестовой платы монтаж и пусконаладочные работы.



Тел: +7 (812) 336 43 04 (многоканальный)

Email: [org@lifeelectronics.ru](mailto:org@lifeelectronics.ru)