

High Performance HCSL Fanout Buffer

Features

- 2 HCSL outputs
- Up to 250MHz output frequency
- Ultra low additive phase jitter: < 0.1 ps (typ)
- Two selectable inputs
- Low delay from input to output (Tpd typ. 1.5ns)
- 2.5V / 3.3V power supply
- Industrial temperature support
- TSSOP-16 package

Description

The PI6C4931502-04 is a high performance fanout buffer device which supports up to 250MHz frequency. This device is ideal for systems that need to distribute low jitter clock signals to multiple destinations.

Applications

- Networking systems including switches and Routers
- High frequency backplane based computing and telecom platforms

Block Diagram

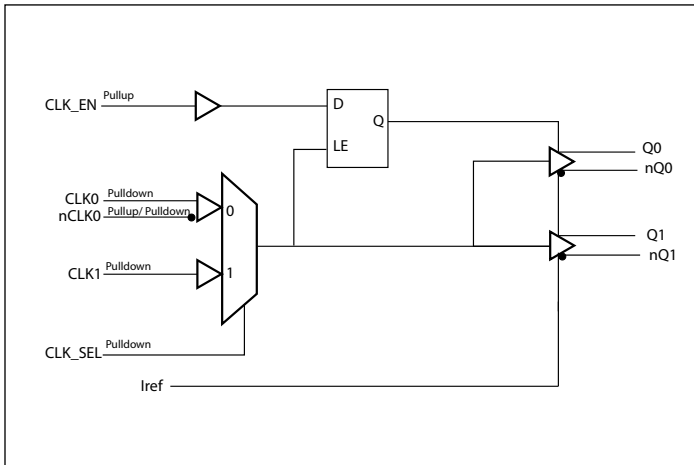

Pin Configuration (16-Pin TSSOP)

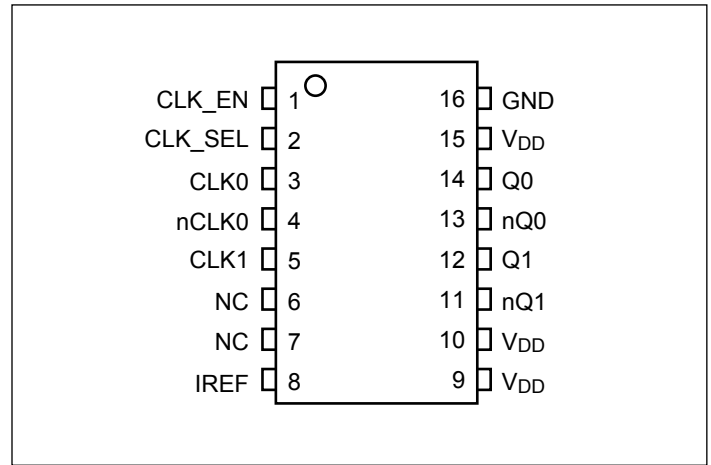

Pin Description

Pin #	Pin Name	Type		Description
1	CLK_EN	Input	Pull Up	Clock output enable/ disable
2	CLK_SEL	Input	Pulldown	Clock input source selection pin
3, 4	CLK0 nCLK0	Input	Pull Up Pull Up/ Pulldown	Differential clock input
5	CLK1	Input	Pulldown	Single ended clock input
6, 7	NC	-		No connect
8	IREF	Output		External resistor connection to set differential output current. Typically 475Ω
9, 10, 15	V _{DD}	Power		Power supply
11, 12	Q1 nQ1	Output		HCSL output clock
13, 14	Q0 nQ0	Output		HCSL output clock
16	GND	Power		Ground

Function Table

Table 1: Input select function

CLK_SEL	Function
0	CLK0, nCLK0
1	CLK1

Table 2: Output Enable function

CLK_EN	Outputs	
	Q0:Q1	nQ0:nQ1
0	Disabled; LOW	Disabled; HIGH
1	Enabled	Enabled

Maximum Ratings (Above which the useful life may be impaired. For user guidelines, not tested)

Storage temperature.....	-55 to +150°C
Supply Voltage to Ground Potential (V_{DD}).....	-0.5 to +4.6V
Inputs (Referenced to GND)	-0.5 to $V_{DD}+0.5V$
Clock Output (Referenced to GND).....	-0.5 to $V_{DD}+0.5V$
Soldering Temperature (Max of 10 seconds)	+260°C

Note:

Stresses greater than those listed under MAXIMUM RATINGS may cause permanent damage to the device. This is a stress rating only and functional operation of the device at these or any other conditions above those indicated in the operational sections of this specification is not implied. Exposure to absolute maximum rating conditions for extended periods may affect reliability.

Power Supply Characteristics and Operating Conditions

Symbol	Parameter	Test Condition	Min.	Typ.	Max.	Units
V_{DD}	Core Supply Voltage		2.97		3.63	V
			2.375		2.625	V
I_{DD}	Power Supply Current	$V_{DD} = 3.3V$, Unloaded			60	mA
		$V_{DD} = 2.5V$, Unloaded			60	
T_A	Ambient Operating Temperature		-40		85	°C

DC Electrical Specifications - Differential Inputs

Symbol	Parameter	Test Condition	Min.	Typ.	Max.	Units
I_{IH}	Input High current: CLK0, nCLK0	Input = V_{DD}			200	uA
I_{IL}	Input Low current: nCLK0		-200			uA
	Input Low current: CLK0		-10			uA
C_{IN}	Input capacitance			4		PF
V_{IH}	Input high voltage				$V_{DD}+0.3$	V
V_{IL}	Input low voltage		-0.3			V
V_{ID}	Input Differential Amplitude PK-PK		150		1300	mV
V_{CM}	Common mode input voltage		GND + 0.5		$V_{DD}-0.85$	V

DC Electrical Specifications - LVCMOS Inputs

Symbol	Parameter		Conditions	Min.	Typ.	Max.	Units
I _{IH}	Input High current	CLK1, CLK_SEL	Input = V _{DD}			200	uA
		CLK_EN				20	uA
I _{IL}	Input Low current	CLK1, CLK_SEL	Input = GND	-10			uA
		CLK_EN		-200			uA
V _{IH}	Input high voltage		V _{DD} =3.3V	2.0		3.765	V
V _{IL}	Input low voltage		V _{DD} =3.3V	-0.3		0.8	V
V _{IH}	Input high voltage		V _{DD} =2.5V	1.7		2.8	V
V _{IL}	Input low voltage		V _{DD} =2.5V	-0.3		0.7	V

DC Electrical Specifications – HCSL Outputs

Parameter	Description	Conditions	Min.	Typ.	Max.	Units
V _{OH}	Output High voltage		520		800	mV
V _{OL}	Output Low voltage		0		150	mV

AC Electrical Specifications – Differential Outputs

Parameter	Description	Conditions	Min.	Typ.	Max.	Units
f _{OUT}	Output frequency				250	MHz
T _r	Output rise time	From 20% to 80%	175		700	ps
T _f	Output fall time	From 80% to 20%	175		700	ps
T _{ODC}	Output duty cycle		47		53	%
T _j	Buffer additive jitter RMS			0.1		ps
V _{MAX}	Absolute Maximum Output Voltage				1150	mV
V _{MIN}	Absolute Minimum Output Voltage		-300			mV
V _{CROSS}	Absolute crossing voltage	HCSL	250		550	mV
DV _{CROSS}	Total variation of crossing voltage	HCSL			140	mV
T _{SK}	Output Skew			40	100	ps
T _{PD}	Propagation Delay			1500		ps
T _{P2P Skew}	Part to Part Skew ¹				600	ps

Notes:

1. This parameter is guaranteed by design

Configuration test load board termination for HCSL Outputs

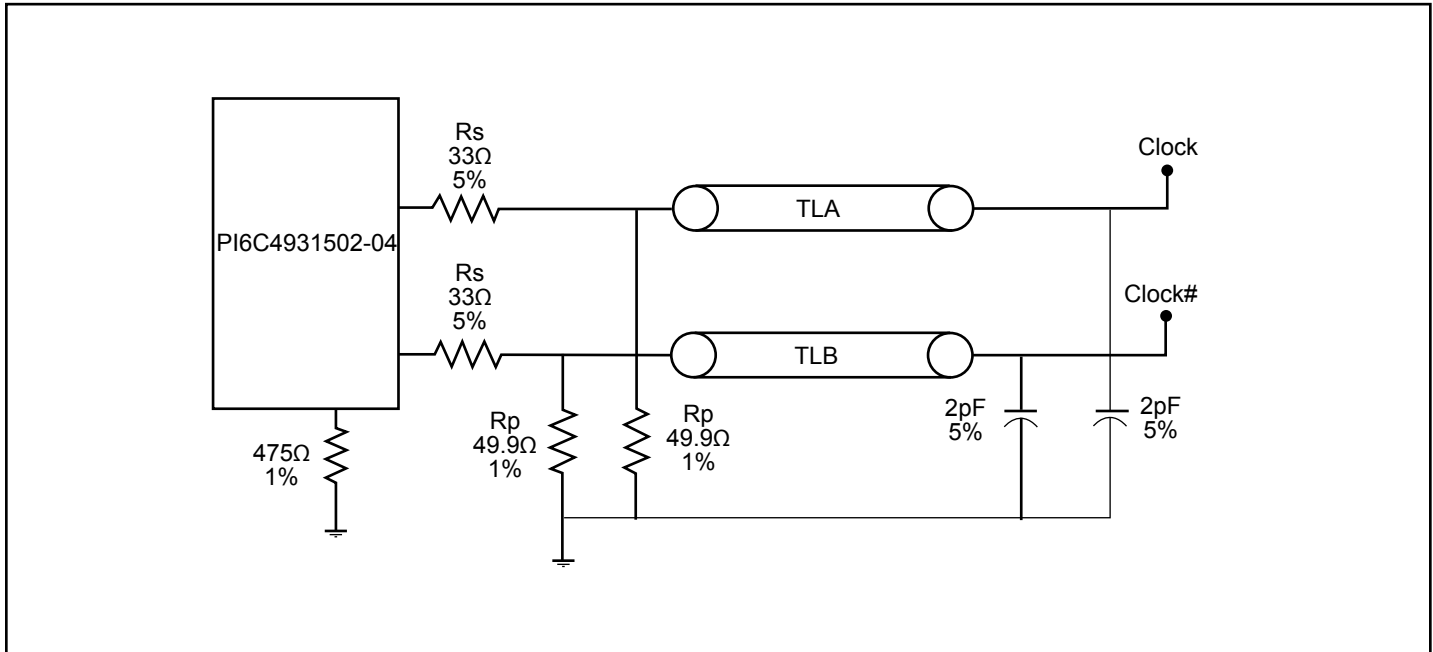

Packaging Mechanical: 16-Pin TSSOP (L)

SYMBOLS	MIN.	NOM.	MAX.
A	–	–	1.20
A1	0.05	–	0.15
A2	0.80	1.00	1.05
b	0.19	–	0.30
c	0.09	–	0.20
D	4.90	5.00	5.10
E1	4.30	4.40	4.50
E	6.20	6.40	6.60
e	0.65 BSC		
L1	1.00 REF		
L	0.45	0.60	0.75
S	0.20	–	–
θ	0°	–	8°

NOTES:
 1. ALL DIMENSIONS IN MILLIMETERS. ANGLES IN DEGREES.
 2. JEDEC MO-153F
 3. DIMENSIONS DOES NOT INCLUDE MOLD FLASH, PROTRUSIONS OR GATE BURRS.

16-0061

		DATE: 03/24/16
DESCRIPTION: 16-Pin, 173mil Wide TSSOP		
PACKAGE CODE: L (L16)		
DOCUMENT CONTROL #: PD-1310	REVISION: G	

Note: For latest package info, please check: <http://www.pericom.com/support/packaging/packaging-mechanicals-and-thermal-characteristics/>

Ordering Information⁽¹⁻³⁾

Ordering Code	Package Code	Description
PI6C4931502-04LIE	L	16-pin, 173mil Wide (TSSOP)
PI6C4931502-04LIEX	L	16-pin, 173mil Wide (TSSOP), Tape & Reel

Notes:

1. Thermal characteristics can be found on the company web site at www.pericom.com/packaging/
2. E = Pb-free and Green
3. Adding an X suffix = Tape/Reel

Mouser Electronics

Authorized Distributor

Click to View Pricing, Inventory, Delivery & Lifecycle Information:

[Diodes Incorporated:](#)

[PI6C4931502-04LIE](#) [PI6C4931502-04LIE](#)

Компания «Life Electronics» занимается поставками электронных компонентов импортного и отечественного производства от производителей и со складов крупных дистрибьюторов Европы, Америки и Азии.

С конца 2013 года компания активно расширяет линейку поставок компонентов по направлению коаксиальный кабель, кварцевые генераторы и конденсаторы (керамические, пленочные, электролитические), за счёт заключения дистрибьюторских договоров

Мы предлагаем:

- Конкурентоспособные цены и скидки постоянным клиентам.
- Специальные условия для постоянных клиентов.
- Подбор аналогов.
- Поставку компонентов в любых объемах, удовлетворяющих вашим потребностям.
- Приемлемые сроки поставки, возможна ускоренная поставка.
- Доставку товара в любую точку России и стран СНГ.
- Комплексную поставку.
- Работу по проектам и поставку образцов.
- Формирование склада под заказчика.
- Сертификаты соответствия на поставляемую продукцию (по желанию клиента).
- Тестирование поставляемой продукции.
- Поставку компонентов, требующих военную и космическую приемку.
- Входной контроль качества.
- Наличие сертификата ISO.

В составе нашей компании организован Конструкторский отдел, призванный помогать разработчикам, и инженерам.

Конструкторский отдел помогает осуществить:

- Регистрацию проекта у производителя компонентов.
- Техническую поддержку проекта.
- Защиту от снятия компонента с производства.
- Оценку стоимости проекта по компонентам.
- Изготовление тестовой платы монтаж и пусконаладочные работы.



Тел: +7 (812) 336 43 04 (многоканальный)
Email: org@lifeelectronics.ru