

# NCV7691GEVB

## NCV7691 Current Controller with Automotive LED Lamps in Sequencing Application Evaluation Board User's Manual



ON Semiconductor®

<http://onsemi.com>

### EVAl BOARD USER'S MANUAL

#### Description

Automotive turn signals are sometimes designed to display an indicator in a fashion such that lights are activated in a sequencing manner to show directional intent.

This evaluation note highlights the use of standard logic integrated circuits with the NCV7691 devices to provide a solution for a sequencing design. The system consists of the LED current controllers (NCV7691 x 3), a voltage regulator (NCV8664), a timer IC (NCV1455B), a shift register (MC74HC164A), and a NAND gate (MC74HC20A).

The evaluation board has an on-board LED array to highlight a sequencing solution for automotive indicators. An additional 10-pin edge connector allows for connection to external LEDs (often at higher current by modifying the current programming resistors).

#### Features

In addition to the NCV7691 part features, this evaluation board highlights the following:

- Sequencing Functionality
- Open Circuit Reporting
  - ◆ Indicator On-board
  - ◆ Connection for Off-board Communication
- External LED Load Connectivity
- Bright / Dim Switch for Easy Viewing
- 5 V Regulator Output

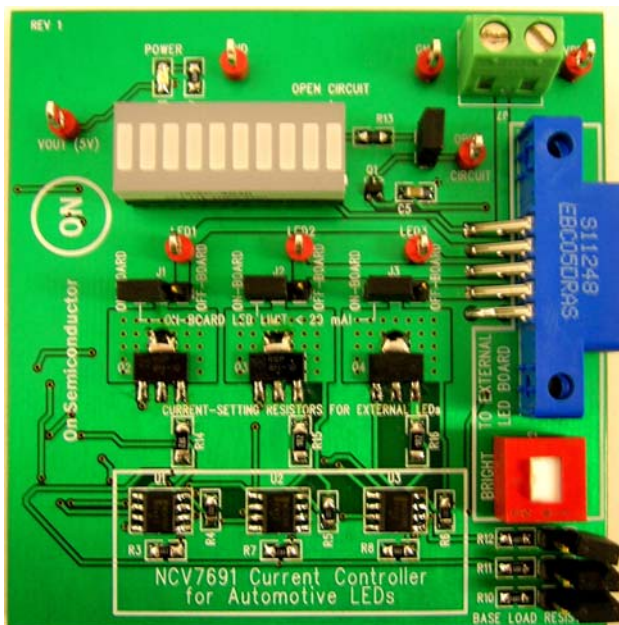

Figure 1. Board Top

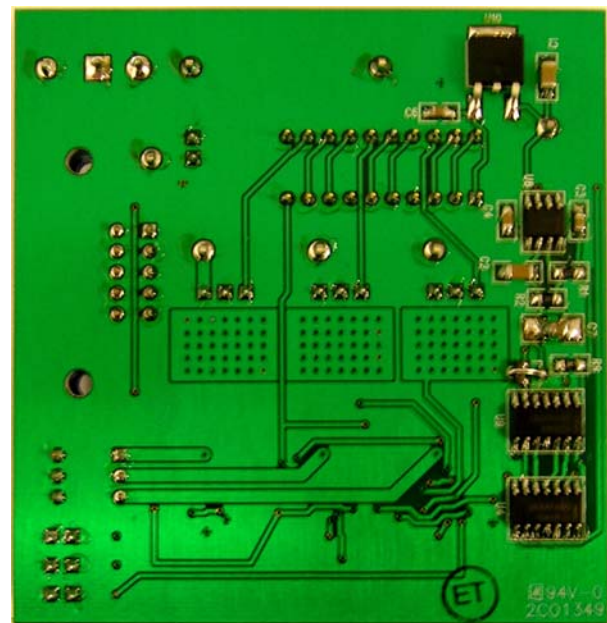
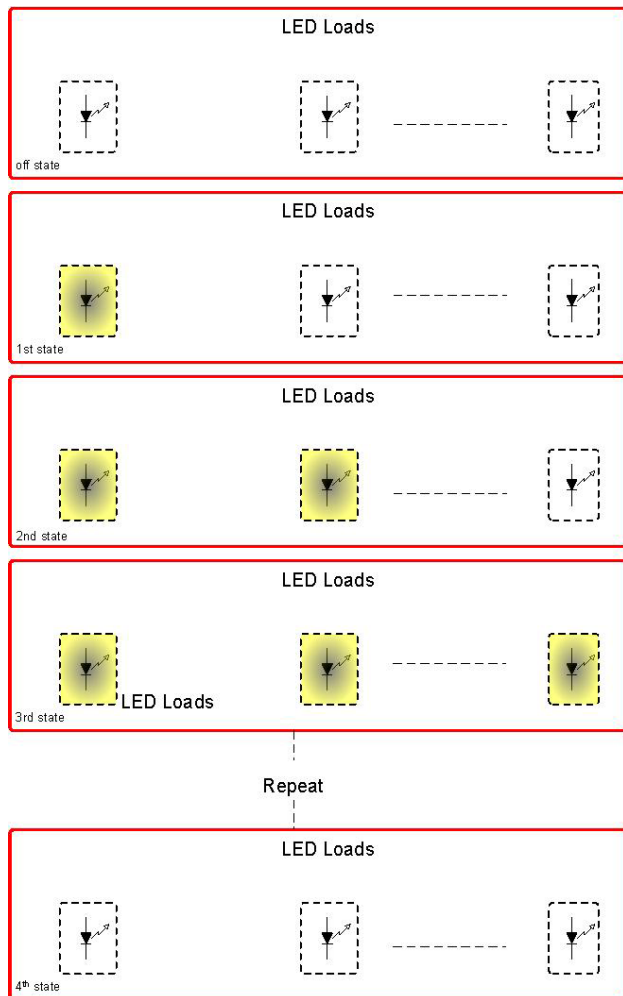

Figure 2. Board Bottom

**Basic Demonstration**

Figure 3 provides a representation of the display feature of this evaluation board.

1. When the board is powered, 3 sets of LED strings are initialized in the off state.
2. The 1<sup>st</sup> string of LEDs turns on.
3. After a delay period, the 2<sup>nd</sup> string of LEDs turns on while the 1<sup>st</sup> string remains illuminated.
4. After a similar delay period, the 3<sup>rd</sup> string of LEDs turns on while the 1<sup>st</sup> and 2<sup>nd</sup> string remain illuminated.
5. All 3 strings remain illuminated for an extended period of time.
6. The progression is repeated as all 3 sets of LED strings transition to the off state.



**Figure 3. NCV7691 Sequencing**

**Open Circuit Detection**

The NCV7691 utilizes the voltage feedback network to the FB pin for detection of open circuit conditions to be reported at the FLTS pin. An open circuit condition using this board can be simulated by removing Jumpers J1, J2, and J3. The open circuit is indicated at the on-board LED bar, but J5 may be removed to route the signal off the board if desired. Detection of open circuit conditions require jumpers J8, J9, and J10 to be connected when using the on-board LED array LED loads.

The low current setup with the LED array using supplied board resistor values for R3, R7, and R8 of 8.2 Ω will illuminate each segment of the LED array at 18 mA. The drive capability of the NCV7691 to the base of the external transistor has a value per the datasheet between 14 mA and 30 mA. An open circuit condition might fail to be detected if all of the drive current is directed to the base of the BCP56 device to the emitter of the BCP56 device through to the sense resistors on the FB pins (R3, R7, R8). e.g. If the drive capability of the NCV7691 is 18 mA, and 18 mA is provided to the base, the voltage at the FB pin will be at the regulation voltage (150 mV) with or without an open circuit event. The voltage generated on the FB pin will be high enough for the system to think the device is regulating and no open circuit exists. This is why three jumpers are provided on the demo board (J8, J9, J10). Connecting these jumpers provides a load directly to the base drive node to eliminate some of the base drive so that an open circuit condition will be detected.

# NCV7691GEVB

## EVALUATION BOARD SCHEMATIC

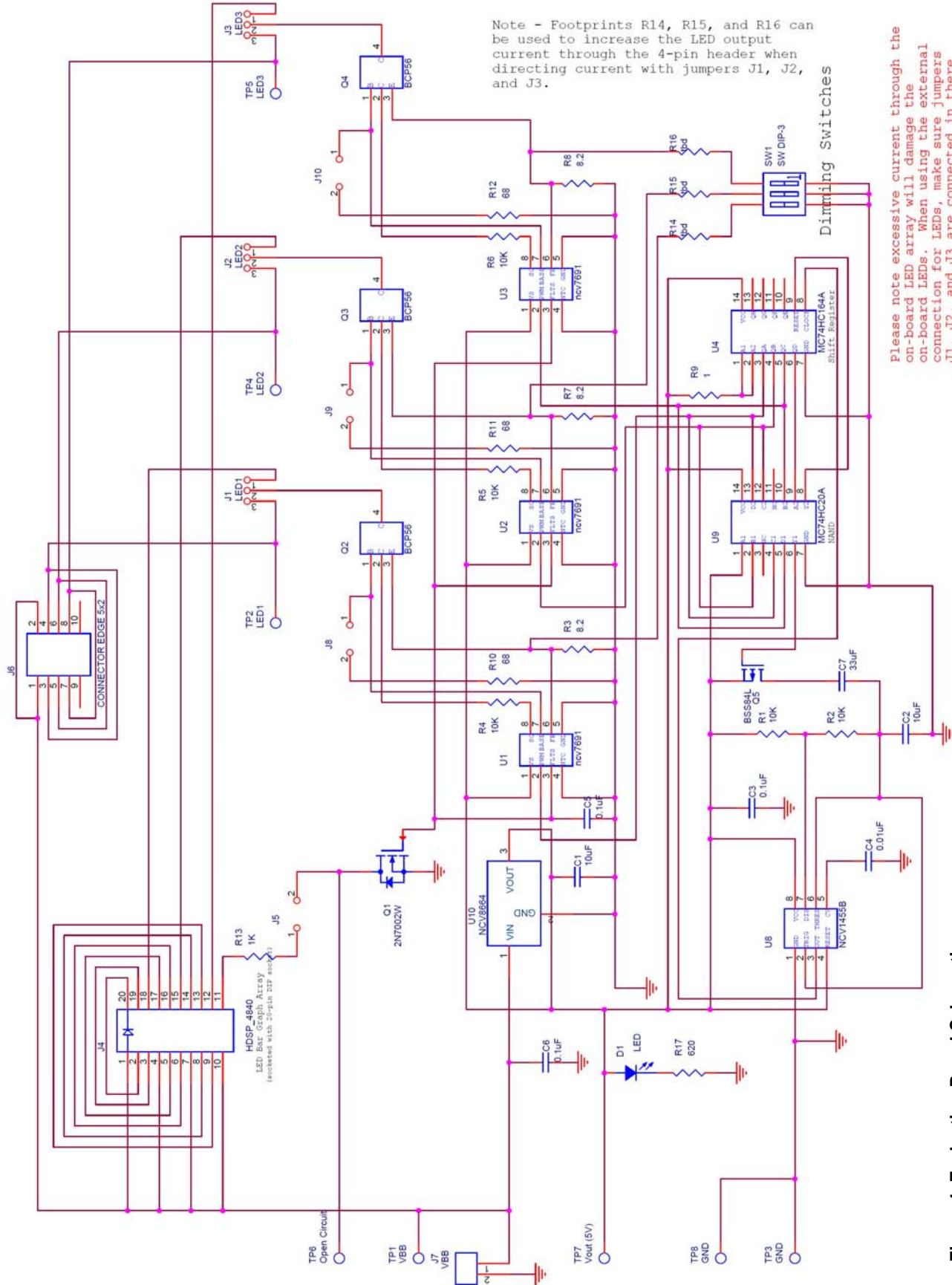

Note - Footprints R14, R15, and R16 can be used to increase the LED output current through the 4-pin header when directing current with jumpers J1, J2, and J3.

Please note excessive current through the on-board LED array will damage the on-board LEDs. When using the external connection for LEDs, make sure jumpers J1, J2, and J3 are connected in their proper location.

Figure 4. Evaluation Board Schematic

# NCV7691GEVB

## THEORY OF OPERATION

The sequencing system design is comprised of all the blocks shown in the diagram below. The Linear regulator provides a 5 V regulated line to the logic ICs (Timer, Shift

Register, and NAND gate). The timer provides the clock for the shift register, and the NAND gate provides the required state to the NCV7691 pre-driver devices.

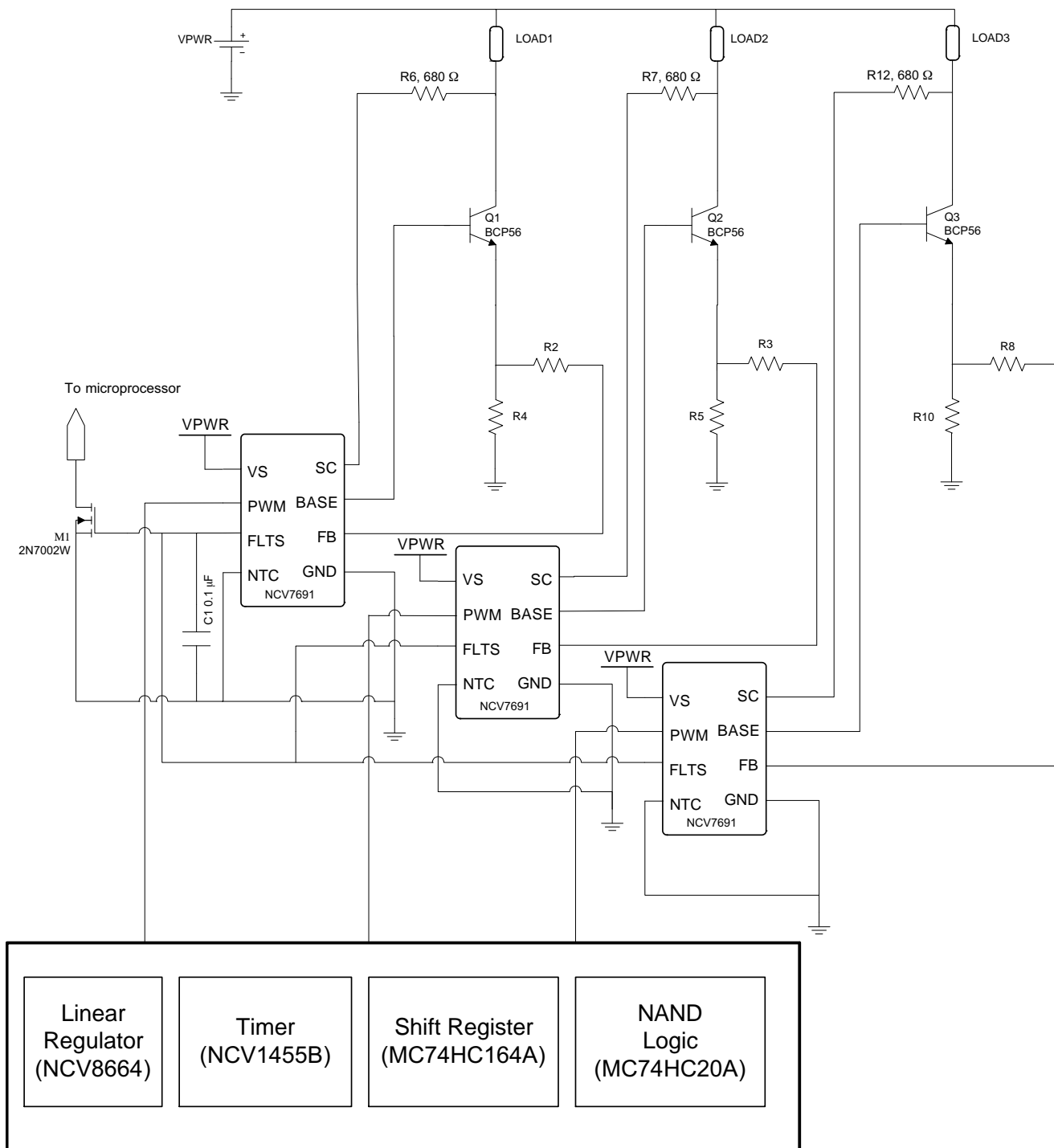

Figure 5.

# NCV7691GEVB

## LOGIC

The NCV1455B timer output is connected to the clock input of the MC74HC164A shift register. At every rising edge of clock, the shift register outputs  $Q_A$ ,  $Q_B$ , and  $Q_C$  change. In four clock pulses, the output  $Q_A Q_B Q_C$  cycles

through values 100, 110, 111, and 000. The following figure displays the timing of these outputs relative to the clock input.

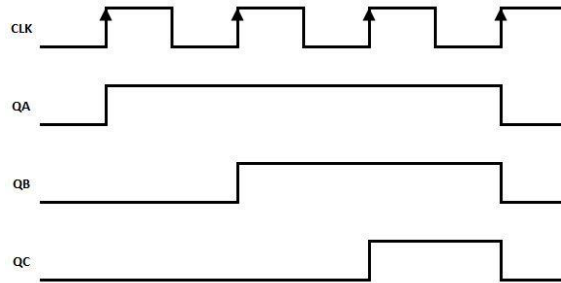

Figure 6. Shift Register Clock Input and Parallel Data Outputs

This is also highlighted in the scope capture of Figure 7.

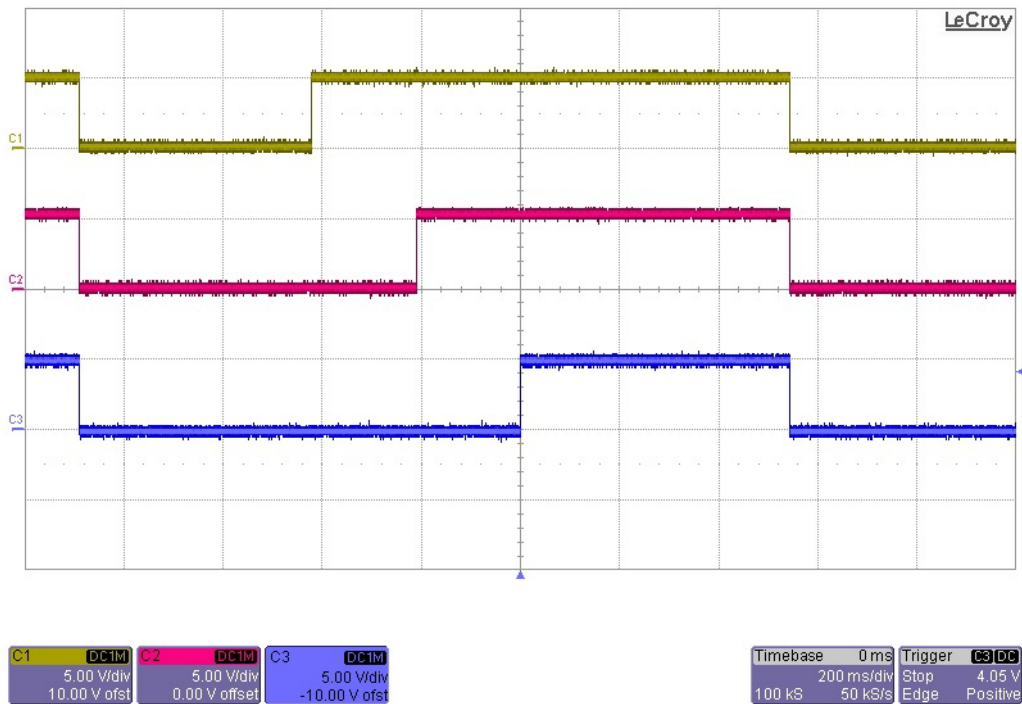

Figure 7. Shift Register (MC74HC164A) Outputs, Pin 3 (yellow), Pin 4 (pink), Pin 5 (blue)

The evaluation board includes three NCV7691 current controller ICs that drive one LED string each. Shift register outputs  $Q_A$ ,  $Q_B$ , and  $Q_C$  are connected directly to the NCV7691 PWM inputs. When the PWM signal goes high, the driver output goes high and the LEDs turn on. Therefore, when the shift register outputs a signal of 100, LED1 is on. A shift register output of 110 corresponds to LED1 and LED2 turning on, and a signal of 111 will turn all three LEDs on. When  $Q_A$ ,  $Q_B$ , and  $Q_C$  are all 0, all three LEDs are off.

The MC74HC20A (NAND) device provides the logic necessary to extend the timer when the 111 condition is present in the shift register. The MC74HC20A interfaces to the BSS84L PFET during this condition adding extra capacitance (C7) in the timer circuit (NCV1455B). Automotive turn signal applications frequently use this to indicate a direction, and then hold the signal present for a duration of time longer than the shifted signal.

# NCV7691GEVB

## ABSOLUTE MAXIMUM RATINGS

The operation of the NCV7691 sequencer evaluation board works as a standalone presentation for the customer highlighting the sequencing function often used in automotive turn signals. The on-board LED array is used for situations where simplicity is needed. An additional edge-connector can be used for alternative LEDs. Jumpers

J1, J2, and J3 provide the interface switch for the edge-connector. Higher currents are assumed to be used with the edge-connector, so extra care must be taken not to reposition the jumpers for high currents through the on-board LED array.

**Table 1. ABSOLUTE MAXIMUM RATINGS**

Rating	Value	Unit
Supply Voltage to board (TP1, VBB) (NCV8664)	-0.3 V (min), 45 (max)	V
LED Current Source (TP2, TP4, TP5) (Edge Connector)(BCP56)	1	A
LED Current Source max voltage (TP2, TP4, TP5) (Edge Connector)(BCP56)	80	V
Open Circuit Voltage (TP6, Open Circuit) (2N7002W)	60	V
Open Circuit Sink Current (TP6, Open Circuit) (2N7002W)	220	mA
Junction Temperature (NCV7691)	-40 to 150	°C
Ambient Temperature (Evaluation Board)	-40 to 105	°C

Stresses exceeding Maximum Ratings may damage the device. Maximum Ratings are stress ratings only. Functional operation above the Recommended Operating Conditions is not implied. Extended exposure to stresses above the Recommended Operating Conditions may affect device reliability.

**Table 2. RECOMMENDED BOARD OPERATING CONDITIONS**

Rating	Value		Unit
	Min	Max	
External Digital Supply Voltage (VBB)	7	16	V
LED Current Source(TP2, TP4, TP5)(Edge Connector) (Note 1)	-	1	A
Junction Temperature (NCV7691)	-40	150	°C

1. Beta of the BCP56 external driver at the specified operating temperature must be considered when operating at high currents in order to obtain the system design goals.

**Table 3. PIN FUNCTION DESCRIPTION**

Connector	Pin Number	Terminal Name	Description
Power	TP1 Edge Connector Pins 1 & 2	VBB	Power supply input voltage (14 V).
	GND	GND	Ground.
Connection Points	TP2 Edge Connector Pins 3 & 4	LED1	Connection to BCP56 collector current source output for U1 (NCV7691).
	TP4 Edge Connector Pins 5 & 6	LED2	Connection to BCP56 collector current source output for U2 (NCV7691).
	TP5 Edge Connector Pins 7 & 8	LED3	Connection to BCP56 collector current source output for U3 (NCV7691).
Test Points	TP6	Open Circuit	Or'd connection from the 3 NCV7691 open circuit detection.
	TP7	Vout (5 V)	Connection to the NCV8664 5 V regulator output.



## NCV7691GEVB

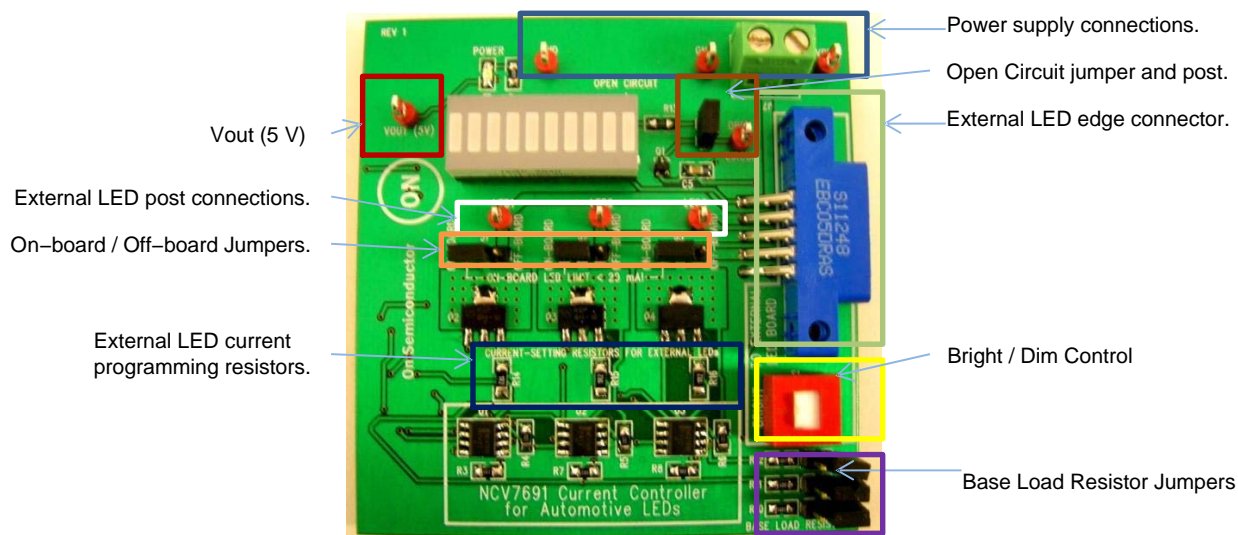

Figure 8. Evaluation Board Highlights

### OPERATIONAL GUIDELINES

The material necessary to successfully use the evaluation boards is listed below:

- NCV7691 Evaluation Board
- 14 V Power Supply Capable of driving 1 A.

Connect a 14 V power supply to the power supply connections. The board should start working immediately.

#### Evaluation Board Options

1. Open Circuit Jumper and Post. Allows disconnection from the drain of the open circuit indicator from the LED array to an external connection.
2. External LED edge connector. Connection for use with external LEDs. Note, the On-board / Off-board jumpers should be moved to the right for off-board connection. Reference the NCV7691/D datasheet for details on choosing a resistor value.
3. Bright / Dim Control. Controls a parallel connection for a programming current resistor for viewing ease.
4. External LED current programming resistors – Current setting resistors for high current switched in with the Bright / Dim dipswitch.
5. On-board / Off-board Jumpers. For setting the board for use with the LED array or an external LED via the edge connector.
6. External LED post connection. Optional connection for external LEDs as an alternative to the edge connector.
7. Vout (5 V). Connection to the 5 V regulator used to power the on-board logic.

#### Using the Evaluation Board with external LEDs

1. Calculate the programming resistor value you need by referring to the NCV7691/D datasheet.
  - a.) At nominal operating voltages the equation for programming current is  $0.15 \text{ V}/R_x$  where  $R_x$  is the equivalent resistance from the NCV7691 FB pin to ground.
  - b.) On the board, using switch SW1 disengaged (DIM), the resistors are R3 (for LED1), R7 (for LED2), and R8 (for LED3). When the switch is engaged (BRIGHT) a resistor is put in parallel with the DIM resistor value. These are R14 (for LED1), R15 (for LED2), and R16 (for LED3).
2. Once the resistors are mounted on the board, move the jumpers from on-board to off-board (J1, J2, and J3).
3. Connect your external LEDs cathode either through the edge connector or the posts (TP2 [LED1], TP4 [LED2], and TP5 [LED3]). The LED anode (string) should be tied to a high voltage (VBB suggested).
4. Connect a 14 V power supply to the power supply connections. The board should start working immediately.

# NCV7691GEVB

**Table 4. JUMPER DESCRIPTION**

Jumper #	Description
J1–J3	Directs current to on-board LED array or external LED board via the edge connector. Removing jumpers simulates an open circuit condition.
J5	Removes open load indicator from LED array to transistor source output (Q1) when jumper is removed.
J8–J10	Adds loads (R10, R11, R12) to the bases of the BCP56 transistors when the jumper is added for use with light loads to allow for open load detection.

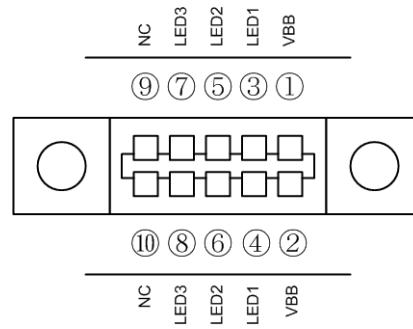

**Figure 9. NCV7691 Sequencing**

## BILL OF MATERIALS

**Table 5. NCV7691 SEQUENCING EVALUATION BOARD BILL OF MATERIALS**

Designator	QTY	Description	Value	Tolerance	Footprint	Manufacturer	Manufacturer Part Number	Substitution Allowed
U1, U2, U3	3	NCV7691 Current Controller	---	---	SOIC-8	ON Semiconductor	NCV7691D1R2G	No
U4	1	8-Bit Serial-Input/Parallel-Output Shift Register	---	---	SOIC-14	ON Semiconductor	MC74HC164ADR2G	Yes
U8	1	Timer	---	---	SOIC-8	ON Semiconductor	NCV1455BDR2G	Yes
U9	1	Dual 4-Input NAND Gate	---	---	SOIC-14	ON Semiconductor	MC74HC20ADR2G	Yes
U10	1	Very Low Iq Low Dropout Linear Regulator	---	---	DPAK	ON Semiconductor	NCV8664DT50RKG	Yes
Q1	1	Small Signal MOSFET	---	---	SC-70 / SOT-323	ON Semiconductor	2N7002WT1G	Yes
Q2, Q3, Q4	3	NPN Silicon Epitaxial Transistor	---	---	SOT-223	ON Semiconductor	BCP56-10T1G	No
Q5	1	Single P. Channel Power MOSFET	---	---	SOT-23-3	ON Semiconductor	BVSS84LT1G	Yes
R1, R2	2	10K Timer Resistor	10K	1%	0805	Vishay/Dale	CRCW080510K0FKEA	Yes
R4, R5, R6	3	10K Short Circuit Interface Resistor	10K	1%	0805	Vishay/Dale	CRCW080510K0FKEA	Yes
R13	1	1K Open-circuit LED drive resistor	1K	1%	0805	Vishay/Dale	CRCW08051K00FKEA	Yes
R3, R7, R8	3	8.2 Ω LED array programming resistors	8.2	1%	0805	Vishay/Dale	CRCW08058R20FKEA	Yes
R9	1	1 Ω Shift register pull-up	1	1%	0805	Vishay/Dale	CRCW08051R00FKEA	Yes
R14, R15, R16	3	High Current programming resistor	Customer Defined	1%	1206	Vishay/Dale	Customer Defined	Yes
R17	1	620 Ω 5 V LED drive resistor	620	1%	0805	Vishay/Dale	CRCW0805620RFKEA	Yes
C1	1	Regulator Output Capacitor	10 μF, 10 V	10%	1206	Murata Electronics North America	GRM31CR61A106KA01L	Yes
C2	1	Timer Capacitor	10 μF, 10 V	10%	1206	Murata Electronics North America	GRM31CR61A106KA01L	Yes
C3	1	Supply Line Filter Capacitor	0.1 μF, 50 V	10%	0805	Murata Electronics North America	GRM21BR71H104KA01L	Yes
C4	1	Timer Control Voltage Capacitor	0.01 μF, 50 V	10%	0805	Murata Electronics North America	GRM216R71H103KA01D	Yes



# NCV7691GEVB

**Table 5. NCV7691 SEQUENCING EVALUATION BOARD BILL OF MATERIALS**

Designator	QTY	Description	Value	Tolerance	Footprint	Manufacturer	Manufacturer Part Number	Substitution Allowed
C5	1	Fault Timer Capacitor	0.1 $\mu$ F, 50 V	10%	0805	Murata Electronics North America	GRM21BR71H104KA01L	Yes
C6	1	Power Supply Input Filter Capacitor	0.1 $\mu$ F, 50 V	10%	0805	Murata Electronics North America	GRM21BR71H104KA01L	Yes
C7	1	Extended Timer Capacitor	33 $\mu$ F	20%	1206	TDK Corporation	C3216X5R1A336M160AB	Yes
D1	1	5 V LED Indicator	---	---	0805	Lite-On Inc	LTST-C171GKT	Yes
J1, J2, J3	3	On-Board / Off-Board Jumper	---	---	JP3	Molex Connector Corporation	22-28-4033	Yes
J4	1	LED Array Socket	---	---	DIP20	3M	4820-3000-CP	Yes
---	1	LED Array	---	---	DIP20	Avago	HDSP-4840	Yes
J5	1	Open Circuit Jumper	---	---	JMP	Molex Connector Corporation	22-28-4023	Yes
J6	1	10-pin Edge Connector	---	---	EDGECONN10	Sullins Connector Solutions	EBC05DRAS	Yes
J7	1	Supply Input Terminal	---	---	MKDSN2	Phoenix Contact	1729128	Yes
SW1	1	Bright / Dim Switch	---	---	DIP6	Grayhill Inc	78G01ST	Yes
TP1-TP8	8	Test Point	---	---	TP	Keystone Electronics	5010	Yes

**ON Semiconductor** and  are registered trademarks of Semiconductor Components Industries, LLC (SCILLC). SCILLC owns the rights to a number of patents, trademarks, copyrights, trade secrets, and other intellectual property. A listing of SCILLC's product/patent coverage may be accessed at [www.onsemi.com/site/pdf/Patent-Marking.pdf](http://www.onsemi.com/site/pdf/Patent-Marking.pdf). SCILLC reserves the right to make changes without further notice to any products herein. SCILLC makes no warranty, representation or guarantee regarding the suitability of its products for any particular purpose, nor does SCILLC assume any liability arising out of the application or use of any product or circuit, and specifically disclaims any and all liability, including without limitation special, consequential or incidental damages. "Typical" parameters which may be provided in SCILLC data sheets and/or specifications can and do vary in different applications and actual performance may vary over time. All operating parameters, including "Typicals" must be validated for each customer application by customer's technical experts. SCILLC does not convey any license under its patent rights nor the rights of others. SCILLC products are not designed, intended, or authorized for use as components in systems intended for surgical implant into the body, or other applications intended to support or sustain life, or for any other application in which the failure of the SCILLC product could create a situation where personal injury or death may occur. Should Buyer purchase or use SCILLC products for any such unintended or unauthorized application, Buyer shall indemnify and hold SCILLC and its officers, employees, subsidiaries, affiliates, and distributors harmless against all claims, costs, damages, and expenses, and reasonable attorney fees arising out of, directly or indirectly, any claim of personal injury or death associated with such unintended or unauthorized use, even if such claim alleges that SCILLC was negligent regarding the design or manufacture of the part. SCILLC is an Equal Opportunity/Affirmative Action Employer. This literature is subject to all applicable copyright laws and is not for resale in any manner.

## PUBLICATION ORDERING INFORMATION

### LITERATURE FULFILLMENT:

Literature Distribution Center for ON Semiconductor  
P.O. Box 5163, Denver, Colorado 80217 USA  
Phone: 303-675-2175 or 800-344-3860 Toll Free USA/Canada  
Fax: 303-675-2176 or 800-344-3867 Toll Free USA/Canada  
Email: [orderlit@onsemi.com](mailto:orderlit@onsemi.com)

**N. American Technical Support:** 800-282-9855 Toll Free  
USA/Canada  
**Europe, Middle East and Africa Technical Support:**  
Phone: 421 33 790 2910  
**Japan Customer Focus Center**  
Phone: 81-3-5817-1050

**ON Semiconductor Website:** [www.onsemi.com](http://www.onsemi.com)

**Order Literature:** <http://www.onsemi.com/orderlit>

For additional information, please contact your local Sales Representative

Компания «Life Electronics» занимается поставками электронных компонентов импортного и отечественного производства от производителей и со складов крупных дистрибьюторов Европы, Америки и Азии.

С конца 2013 года компания активно расширяет линейку поставок компонентов по направлению коаксиальный кабель, кварцевые генераторы и конденсаторы (керамические, пленочные, электролитические), за счёт заключения дистрибьюторских договоров

Мы предлагаем:

- Конкурентоспособные цены и скидки постоянным клиентам.
- Специальные условия для постоянных клиентов.
- Подбор аналогов.
- Поставку компонентов в любых объемах, удовлетворяющих вашим потребностям.
- Приемлемые сроки поставки, возможна ускоренная поставка.
- Доставку товара в любую точку России и стран СНГ.
- Комплексную поставку.
- Работу по проектам и поставку образцов.
- Формирование склада под заказчика.
- Сертификаты соответствия на поставляемую продукцию (по желанию клиента).
- Тестирование поставляемой продукции.
- Поставку компонентов, требующих военную и космическую приемку.
- Входной контроль качества.
- Наличие сертификата ISO.

В составе нашей компании организован Конструкторский отдел, призванный помогать разработчикам, и инженерам.

Конструкторский отдел помогает осуществить:

- Регистрацию проекта у производителя компонентов.
- Техническую поддержку проекта.
- Защиту от снятия компонента с производства.
- Оценку стоимости проекта по компонентам.
- Изготовление тестовой платы монтаж и пусконаладочные работы.



Тел: +7 (812) 336 43 04 (многоканальный)  
Email: [org@lifeelectronics.ru](mailto:org@lifeelectronics.ru)