

# P3I2005A

## General Purpose Peak EMI Reduction IC

### Product Description

P3I2005A is a versatile, 3.3 V / 5 V, 1x spread spectrum frequency modulator designed to reduce electromagnetic interference (EMI) at the clock source, allowing system wide reduction of EMI of down stream clock and data dependent signals. The device allows significant system cost savings by reducing the number of circuit board layers ferrite beads, shielding and other passive components that are traditionally required to pass EMI regulations.

P3I2005A modulates the output of a PLL in order to “spread” the bandwidth of a synthesized clock, and more importantly, decreases the peak amplitudes of its harmonics. This results in significantly lower system EMI compared to the typical narrow band signal produced by oscillators and most frequency generators. Lowering EMI by increasing a signal’s bandwidth is called ‘spread spectrum clock generation’.

P3I2005A accepts an input from an external reference clock and locks to a 1x modulated clock output. Two logic pins S0 and D\_C enable selecting one of the 4 different frequency deviations. Refer *Deviation Selection table*. Frequency Range Selection pin enables operation in one of the two frequency ranges. P3I2005A operates over a supply voltage range of 5 V / 3.3 V. P3I2005A is available in 8 Pin SOIC Package.

### Features

- 1x, LVCMOS Peak EMI Reduction
- Input Clock Frequency : 10 MHz – 100 MHz
- Output Clock Frequency : 10 MHz – 100 MHz
- Four different Frequency Deviation selection
- Frequency range Selection
- Supply voltage:  $5\text{ V} \pm 0.5\text{ V}$   
 $3.3\text{ V} \pm 0.3\text{ V}$
- 8 Pin SOIC Package
- These Devices are Pb-Free, Halogen Free/BFR Free and are RoHS Compliant

### Application

- P3I2005A is targeted for use in a broad range of notebook and desktop PCs and consumer electronic applications.



ON Semiconductor®

<http://onsemi.com>



SOIC-8  
CASE 751

### MARKING DIAGRAM

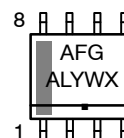

AFG = Specific Device Code  
A = Assembly Location  
L = Wafer Lot  
Y = Year  
W = Work Week  
▪ = Pb-Free Package

### PIN CONFIGURATION

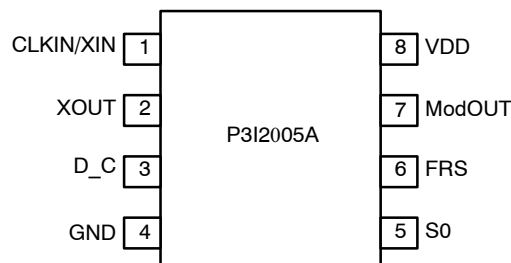

### ORDERING INFORMATION

See detailed ordering and shipping information in the package dimensions section on page 5 of this data sheet.

# P3I2005A

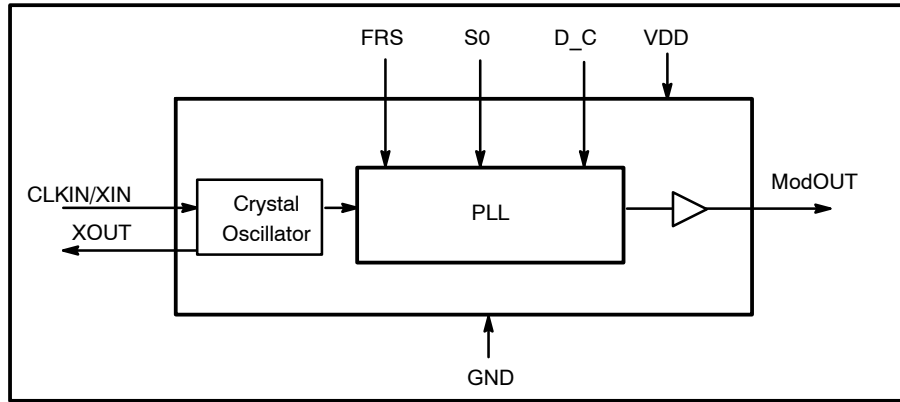

Figure 1. Block Diagram

## PIN DESCRIPTION

Pin#	Pin Name	Type	Description
1	CLKIN / XIN	I	External reference Clock input or Crystal connection.
2	XOUT	O	Crystal connection. If using an external reference, this pin must be left unconnected.
3	D_C	I	Deviation Selection. Has an internal pull-up resistor. <i>Refer to Deviation Selection table</i>
4	GND	P	Ground connection.
5	S0	I	Deviation Selection. Has an internal pull-up resistor. <i>Refer to Deviation Selection table</i>
6	FRS	I	Frequency Range Selection. Has an internal pull-up resistor
7	ModOUT	O	Buffered Modulated Clock Output.
8	VDD	P	Power supply for the entire chip(3.3 V/5 V)

## FREQUENCY RANGE SELECTION TABLE

FRS	Frequency(MHz)
0	10 – 30
1	30 – 100

## DEVIATION SELECTION TABLE

		Deviation (%)					
D_C	S0	FS = 0			FS = 1		
		10 MHz	20 MHz	30 MHz	30 MHz	80 MHz	100 MHz
0	0	-4.5	-3.6	-1.7	-4.8	-3.6	-2.6
0	1	-2.6	-2	-1	-2.7	-2	-1.5
1	0	±2.6	±2	±1	±2.75	±2	±1.5
1	1	±1.7	±1.25	±0.7	±1.8	±1.25	±1

# P3I2005A

## OPERATING CONDITIONS

Symbol	Parameter	Min	Max	Unit
VDD(5V)	Supply Voltage	4.5	5.5	V
VDD(3.3V)	Supply Voltage	3	3.6	V
T <sub>A</sub>	Operating Temperature	-40	+85	°C
C <sub>L</sub>	Load Capacitance		15	pF
C <sub>IN</sub>	Input Capacitance		7	pF

## ABSOLUTE MAXIMUM RATINGS

Symbol	Parameter	Rating	Unit
VDD, V <sub>IN</sub>	Voltage on any input pin with respect to Ground	-0.5 to +7.0	V
T <sub>STG</sub>	Storage temperature	-65 to +125	°C
T <sub>s</sub>	Max. Soldering Temperature (10 sec)	260	°C
T <sub>J</sub>	Junction Temperature	150	°C
T <sub>DV</sub>	Static Discharge Voltage (As per JEDEC STD22- A114-B)	2	kV

Stresses exceeding Maximum Ratings may damage the device. Maximum Ratings are stress ratings only. Functional operation above the Recommended Operating Conditions is not implied. Extended exposure to stresses above the Recommended Operating Conditions may affect device reliability.

## DC ELECTRICAL CHARACTERISTICS FOR V<sub>DD</sub> = 5 V ± 0.5 V

Symbol	Parameter	Min	Typ	Max	Unit
VDD	Operating voltage	4.5	5.0	5.5	V
V <sub>IL</sub>	Input low voltage	GND - 0.3		0.8	V
V <sub>IH</sub>	Input high voltage	2.0		V <sub>DD</sub> + 0.3	V
I <sub>IL</sub>	Input low current			100	μA
I <sub>IH</sub>	Input high current			100	μA
V <sub>OL</sub>	Output low voltage (I <sub>OL</sub> = 12 mA)			0.4	V
V <sub>OH</sub>	Output high voltage (I <sub>OH</sub> = -12 mA)	2.5			V
I <sub>CC</sub>	Static supply current (CLKIN/XIN pulled to GND)			12	mA
I <sub>DD</sub>	Dynamic supply current (Unloaded Output)	FS = 0 (@ 30 MHz)		34	mA
		FS = 1 (@ 100 MHz)		40	
Z <sub>OUT</sub>	Output impedance		30		Ω

## P3I2005A

### AC ELECTRICAL CHARACTERISTICS FOR $V_{DD} = 5 V \pm 0.5 V$

Symbol	Parameter	Min	Typ	Max	Unit
CLKIN/XIN	Input Clock Frequency	FRS = 0		30	MHz
		FRS = 1	10	100	
MODOUT	Output Clock Frequency	FRS = 0		30	MHz
		FRS = 1	10	100	
$t_{LH}$ (Notes 1 & 2)	Output Rise time (measured between 20% to 80%)		1.6	2	nS
$t_{HL}$ (Notes 1 & 2)	Output Fall time (measured between 80% to 20%)		1.2	1.6	nS
$t_D$ (Notes 1 & 2)	Output duty cycle	45	50	55	%
$t_{JC}$ (Note 2)	Jitter (cycle to cycle) @ FS = 0, 24 MHz and FS = 1, 80 MHz		$\pm 250$	$\pm 350$	pS
$t_{ON}$ (Notes 1 & 2)	PLL lock time (Stable VDD, valid Clock presented on CLKIN/XIN)			3	mS

1. All parameters are specified with 15 pF loaded output.
2. Parameter is guaranteed by design and characterization. Not 100% tested in production

### DC ELECTRICAL CHARACTERISTICS FOR $V_{DD} = 3.3 V \pm 0.3 V$

Symbol	Parameter	Min	Typ	Max	Unit
VDD	Operating voltage	3	3.3	3.6	V
$V_{IL}$	Input low voltage	GND - 0.3		0.8	V
$V_{IH}$	Input high voltage	2.0		VDD + 0.3	V
$I_{IL}$	Input low current			100	$\mu A$
$I_{IH}$	Input high current			100	$\mu A$
$V_{OL}$	Output low voltage ( $I_{OL} = 12 \text{ mA}$ )			0.4	V
$V_{OH}$	Output high voltage ( $I_{OH} = -12 \text{ mA}$ )	2.5			V
$I_{CC}$	Static supply current (CLKIN/XIN pulled to GND)			11	mA
$I_{DD}$	Dynamic supply current (Unloaded Output)	FS = 0 (@ 30 MHz)		26	mA
		FS = 1 (@ 100 MHz)		32	
$Z_{OUT}$	Output impedance		40		$\Omega$

# P3I2005A

## AC ELECTRICAL CHARACTERISTICS FOR $V_{DD} = 3.3 V \pm 0.3 V$

Symbol	Parameter	Min	Typ	Max	Unit
CLKIN/XIN	Input Clock Frequency	FRS = 0		30	MHz
		FRS = 1	10	100	
MODOUT	Output Clock Frequency	FRS = 0		30	MHz
		FRS = 1	10	100	
$t_{LH}$ (Notes 3 & 4)	Output Rise time (measured between 20% to 80%)		1.9	2.5	nS
$t_{HL}$ (Notes 3 & 4)	Output Fall time (measured between 80% to 20%)		1.5	2	nS
$t_D$ (Notes 3 & 4)	Output duty cycle	45	50	55	%
$t_{JC}$ (Note 4)	Jitter (cycle to cycle) @ FS=0, 24MHz & FS=1, 80 MHz		$\pm 250$	$\pm 350$	pS
$t_{ON}$ (Notes 3 & 4)	PLL lock time (Stable VDD, valid Clock presented on CLKIN/XIN)			3	mS

3. All parameters are specified with 15 pF loaded output.

4. Parameter is guaranteed by design and characterization. Not 100% tested in production

## ORDERING INFORMATION

Part Number	Marking	Package	Temperature	Shipping <sup>†</sup>
P3I2005AG-08SR	AFG	8-PIN SOIC (Pb-Free)	-40°C to +85°C	Tape & Reel

<sup>†</sup>For information on tape and reel specifications, including part orientation and tape sizes, please refer to our Tape and Reel Packaging Specifications Brochure, BRD8011/D.

\*A "microdot" placed at the end of last row of marking or just below the last row toward the center of package indicates Pb-Free.

# P3I2005A

## PACKAGE DIMENSIONS

SOIC-8 NB  
CASE 751-07  
ISSUE AJ

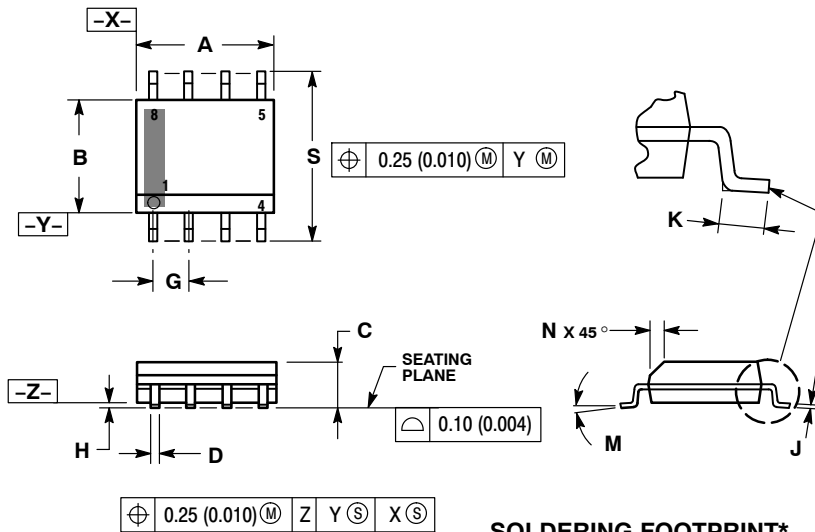

**NOTES:**

1. DIMENSIONING AND TOLERANCING PER ANSI Y14.5M, 1982.
2. CONTROLLING DIMENSION: MILLIMETER.
3. DIMENSION A AND B DO NOT INCLUDE MOLD PROTRUSION.
4. MAXIMUM MOLD PROTRUSION 0.15 (0.006) PER SIDE.
5. DIMENSION D DOES NOT INCLUDE DAMBAR PROTRUSION. ALLOWABLE DAMBAR PROTRUSION SHALL BE 0.127 (0.005) TOTAL IN EXCESS OF THE D DIMENSION AT MAXIMUM MATERIAL CONDITION.
6. 751-01 THRU 751-06 ARE OBSOLETE. NEW STANDARD IS 751-07.

DIM	MILLIMETERS		INCHES	
	MIN	MAX	MIN	MAX
A	4.80	5.00	0.189	0.197
B	3.80	4.00	0.150	0.157
C	1.35	1.75	0.053	0.069
D	0.33	0.51	0.013	0.020
G	1.27 BSC		0.050 BSC	
H	0.10	0.25	0.004	0.010
J	0.19	0.25	0.007	0.010
K	0.40	1.27	0.016	0.050
M	0°	8°	0°	8°
N	0.25	0.50	0.010	0.020
S	5.80	6.20	0.228	0.244

### SOLDERING FOOTPRINT\*

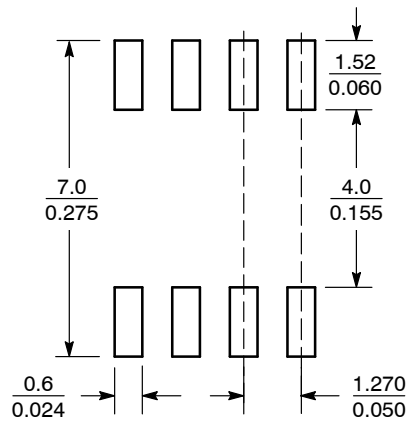

SCALE 6:1 (mm/inches)

\*For additional information on our Pb-Free strategy and soldering details, please download the ON Semiconductor Soldering and Mounting Techniques Reference Manual, SOLDERRM/D.

ON Semiconductor and are registered trademarks of Semiconductor Components Industries, LLC (SCILLC). SCILLC reserves the right to make changes without further notice to any products herein. SCILLC makes no warranty, representation or guarantee regarding the suitability of its products for any particular purpose, nor does SCILLC assume any liability arising out of the application or use of any product or circuit, and specifically disclaims any and all liability, including without limitation special, consequential or incidental damages. "Typical" parameters which may be provided in SCILLC data sheets and/or specifications can and do vary in different applications and actual performance may vary over time. All operating parameters, including "Typicals" must be validated for each customer application by customer's technical experts. SCILLC does not convey any license under its patent rights nor the rights of others. SCILLC products are not designed, intended, or authorized for use as components in systems intended for surgical implant into the body, or other applications intended to support or sustain life, or for any other application in which the failure of the SCILLC product could create a situation where personal injury or death may occur. Should Buyer purchase or use SCILLC products for any such unintended or unauthorized application, Buyer shall indemnify and hold SCILLC and its officers, employees, subsidiaries, affiliates, and distributors harmless against all claims, costs, damages, and expenses, and reasonable attorney fees arising out of, directly or indirectly, any claim of personal injury or death associated with such unintended or unauthorized use, even if such claim alleges that SCILLC was negligent regarding the design or manufacture of the part. SCILLC is an Equal Opportunity/Affirmative Action Employer. This literature is subject to all applicable copyright laws and is not for resale in any manner.

### PUBLICATION ORDERING INFORMATION

**LITERATURE FULFILLMENT:**  
Literature Distribution Center for ON Semiconductor  
P.O. Box 5163, Denver, Colorado 80217 USA  
**Phone:** 303-675-2175 or 800-344-3860 Toll Free USA/Canada  
**Fax:** 303-675-2176 or 800-344-3867 Toll Free USA/Canada  
**Email:** orderlit@onsemi.com

**N. American Technical Support:** 800-282-9855 Toll Free USA/Canada  
**Europe, Middle East and Africa Technical Support:**  
Phone: 421 33 790 2910  
**Japan Customer Focus Center**  
Phone: 81-3-5773-3850

**ON Semiconductor Website:** [www.onsemi.com](http://www.onsemi.com)  
**Order Literature:** <http://www.onsemi.com/orderlit>  
For additional information, please contact your local Sales Representative

Компания «Life Electronics» занимается поставками электронных компонентов импортного и отечественного производства от производителей и со складов крупных дистрибьюторов Европы, Америки и Азии.

С конца 2013 года компания активно расширяет линейку поставок компонентов по направлению коаксиальный кабель, кварцевые генераторы и конденсаторы (керамические, пленочные, электролитические), за счёт заключения дистрибьюторских договоров

Мы предлагаем:

- Конкурентоспособные цены и скидки постоянным клиентам.
- Специальные условия для постоянных клиентов.
- Подбор аналогов.
- Поставку компонентов в любых объемах, удовлетворяющих вашим потребностям.
- Приемлемые сроки поставки, возможна ускоренная поставка.
- Доставку товара в любую точку России и стран СНГ.
- Комплексную поставку.
- Работу по проектам и поставку образцов.
- Формирование склада под заказчика.
- Сертификаты соответствия на поставляемую продукцию (по желанию клиента).
- Тестирование поставляемой продукции.
- Поставку компонентов, требующих военную и космическую приемку.
- Входной контроль качества.
- Наличие сертификата ISO.

В составе нашей компании организован Конструкторский отдел, призванный помогать разработчикам, и инженерам.

Конструкторский отдел помогает осуществить:

- Регистрацию проекта у производителя компонентов.
- Техническую поддержку проекта.
- Защиту от снятия компонента с производства.
- Оценку стоимости проекта по компонентам.
- Изготовление тестовой платы монтаж и пусконаладочные работы.



Тел: +7 (812) 336 43 04 (многоканальный)

Email: [org@lifeelectronics.ru](mailto:org@lifeelectronics.ru)