

Universal-Input/15 W 67 kHz Flyback Switching Regulator

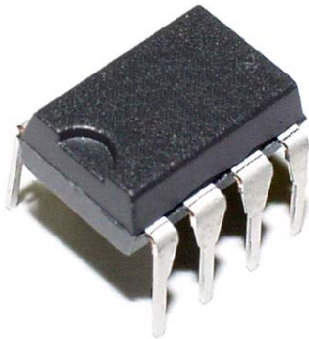

ABSOLUTE MAXIMUM RATINGS at $T_A = +25^\circ\text{C}$

Control Supply Voltage, V_{CC}	36 V
Drain-Source Voltage, V_{DSS}	650 V
Drain Switching Current, I_D	2.5 A*
Peak Drain Switching Current, I_{DM}	2.5 A
Single-Pulse Avalanche Energy, E_{AS}	72 mJ
S/OCP Voltage Range, V_{OCP}	-0.3 V to +6 V
FB/CC/OLP Voltage Range, $V_{FB/OLP}$	-0.3 V to +12 V
FM Voltage Range, V_{FM}	-0.3 V to +6 V
Package Power Dissipation, P_D control ($V_{CC} \times I_{CC(ON)}$)	0.15 W
MOSFET ($V_{DSS} \times I_D$)	1.35 W
total	1.5 W
MOSFET Channel Temp., T_J	+150°C
Internal Frame Temp., T_F	+125°C
Storage Temperature Range, T_S	-40°C to +125°C

* Drain switching current is limited by temperature (page 2) and safe operating area (page 4).

The STR-A6251M is a 67 kHz PWM topology (with $\pm 5\%$ frequency jittering for minimum EMI) regulator specifically designed to satisfy the requirements for increased integration and reliability in flyback converters. It incorporates a primary control and drive circuit with an avalanche-rated power MOSFET. This is a higher-frequency version of the STR-A6251.

Covering the power range from below 21 watts for a 230 VAC input, or to 15 watts for a universal (85 to 264 VAC) input, this device can be used in a wide range of applications, from DVD players and VCR player/recorders to ac adapters for cellular phones and digital cameras. An auto-burst standby function reduces power consumption at light load, while multiple protections, including the avalanche-energy guaranteed MOSFET, provide high reliability of system design.

Cycle-by-cycle current limiting, undervoltage lockout with hysteresis, overvoltage protection, and thermal shutdown protect the power supply during the normal overload and fault conditions. Overvoltage protection and thermal shutdown are latched after a short delay. The latch may be reset by cycling the input supply. Low start-up current and a low-power standby mode selected from the secondary circuit completes a comprehensive suite of features. It is provided in an 8-pin mini-DIP plastic package with pin 6 removed.

FEATURES AND BENEFITS

- 67 kHz PWM with $\pm 5\%$ Frequency Jittering
Cost Reduction of EMI Noise Filtering
- Rugged 650 V Avalanche-Rated MOSFET
Simplified Surge Absorption
No V_{DSS} Derating Required
- Low $r_{DS(on)}$ (3.95 Ω maximum)
- Auto-Burst Mode for Stand-By Operation or Light Loads
Less Transformer Audible Noise
- Built-In Leading Edge Blanking
- Soft Start and Low Start-Up Current
Start-Up Circuit Disabled in Operation
- Low Operating Current (4 mA max)
- Automatic Burst Stand-By (intermittent operation)
Input Power <0.1 W at No Load

continued

Always order by complete part number, e.g., **STR-A6251M**.

STR-A6251M
Universal-Input/15 W
67 kHz Flyback Switching Regulator

**Switching
Regulators**

FUNCTIONAL BLOCK DIAGRAM

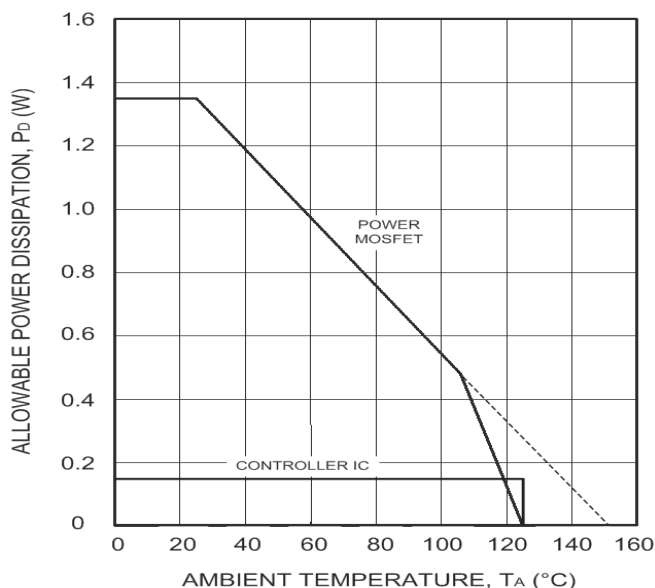
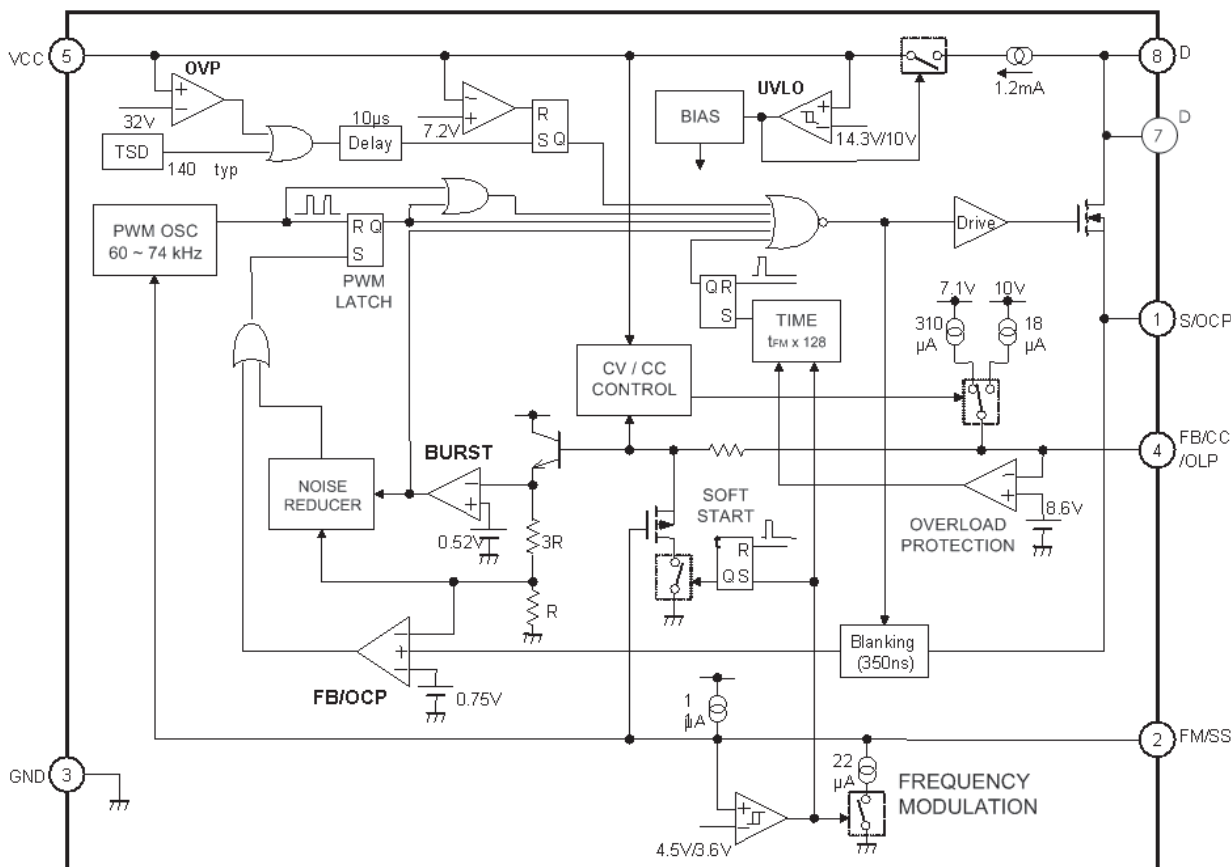

FEATURES AND BENEFITS (cont'd)

- Auto-Bias Function
Stable Burst Operation Without Generating Interference
- Internal Off-Timer Circuit
- Built-In Constant-Voltage/Constant Current
- Multiple Protections:
Pulse-by-Pulse Overcurrent Protection (OCP)
Overload Protection (OLP) with Auto Restart
Latching Overvoltage Protection (OVP)
Undervoltage Lockout (UVLO) with Hysteresis
Latching Thermal Shutdown (TSD)
- Molded Small-Size 8-Pin Package
For Low-Height SMPS

This data sheet is based on Sanken data sheet SSE-23420.

ELECTRICAL CHARACTERISTICS at $T_A = 25^\circ\text{C}$, $V_{CC} = 18\text{ V}$ (unless otherwise specified).

Characteristic	Pin No.	Symbol	Test Conditions	Ratings			
				Min	Typ	Max	Units
Drain-to-Source Breakdown Volt.	8 - 1	$V_{(BR)DSS}$	$I_D = 300\ \mu\text{A}$, $V_1 - V_3 = 0\text{ V}$ (short)	650	-	-	V
Drain Leakage Current	8	I_{DSS}	$V_{DS} = 650\text{ V}$, $V_1 - V_3 = 0\text{ V}$ (short)	-	-	300	μA
On-State Resistance	8 - 1	$r_{DS(on)}$	$I_D = 0.4\text{ A}$	-	-	3.95	Ω
MOSFET Switching Time	8 - 3	t_f	-	-	-	250	ns
Operation-Start Voltage	5 - 3	$V_{CC(ON)}$	$V_{CC} = 0 \rightarrow 15.7\text{ V}$	12.9	14.3	15.7	V
Operation-Stop Voltage	5 - 3	$V_{CC(OFF)}$	$V_{CC} = 15.7 \rightarrow 9\text{ V}$	9.0	10	11	V
Maximum Switching Frequency	8 - 3	$f_{osc(max)}$	-	60	67	74	kHz
Frequency-Jitter Deviation	8 - 3	Δf_{osc}	-	4.0	6.7	9.4	kHz
Maximum ON Duty Cycle	8 - 3	D max	-	70	76	82	%
Circuit Current in Operation	5	$I_{CC(ON)}$	-	-	-	4.0	mA
Circuit Current in Non-Operation	5	$I_{CC(OFF)}$	$V_{CC} = 12\text{ V}$	-	14	25	μA
FM Voltage	2 - 3	V_{FMH}	$f_{osc} = f_{osc(max)}$	4.0	4.5	5.0	V
		V_{FML}	$f_{osc} < f_{osc(max)}$	3.2	3.6	4.0	V
FM Current	2	I_{FMH}		-7.7	-11.0	-15.4	μA
		I_{FML}		7.7	11.0	15.4	μA
OCP Threshold Voltage	1 - 3	V_{OCP}	-	0.67	0.74	0.81	V
Leading Edge Blanking Time	8 - 3	t_{bw}	-	240	350	460	ns
Burst Threshold Voltage	4 - 3	V_{burst}	-	1.00	1.12	1.24	V
OLP Threshold Voltage	4 - 3	V_{OLP}	-	7.3	8.6	9.9	V
Current at OLP Operation	4	I_{OLP}	-	-12	-18	-25	μA
OLP Delay Time	4 - 3	t_{OLP}	-	0.84	1.20	1.56	s
Maximum FB Current	4	$I_{FB(MAX)}$	-	220	310	430	μA
CC Set Voltage	4 - 3	$V_{SET(CC)}$	-	4.9	5.8	6.7	V
CC Reset Voltage	4 - 3	$V_{RES(CC)}$	$V_{CC} = 25\text{ V}$	3.5	3.9	4.3	V
Start-Up Current	5	$I_{startup}$	$V_{CC} = 13\text{ V}$	0.84	1.20	1.56	mA
OVP Operation Voltage	5 - 3	$V_{CC(OVP)}$	$V_{CC} = 18 \rightarrow 35.2\text{ V}$	28.8	32.0	35.2	V
OVP/TSD Latch Sustaining Current	5	$I_{CC(H)}$	$V_{CC} = 35.2 \rightarrow 8.6\text{ V}$	-	-	270	μA
OVP/TSD Latch Release Voltage	5 - 3	V_{CC}	$V_{CC} = 35.2 \rightarrow 5.9\text{ V}$	5.9	7.2	8.6	V
Thermal Shutdown	-	T_J	-	125	140	-	$^\circ\text{C}$
Thermal Resistance	-	$R_{\theta JF}$	-	-	-	52	$^\circ\text{C/W}$

Typical values are given for circuit design information only.

Negative current is defined as coming out of (sourcing) the specified terminal.

STR-A6251M
Universal-Input/15 W
67 kHz Flyback Switching Regulator

Switching
Regulators

MOSFET TYPICAL CHARACTERISTICS

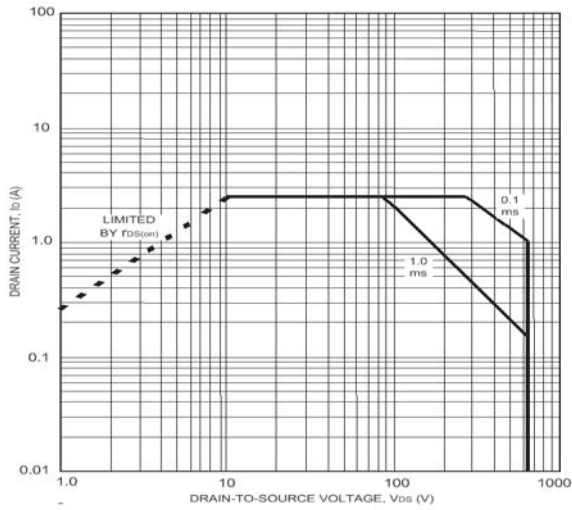

Recommended Operating Conditions

Operating Ambient Temperature -20°C to +100°C
 Operating Junction Temperature -20°C to +125°C
 Maximum Frame Temperature +115°C

For the availability of parts meeting -40°C requirements, contact Allegro's Sales Representative.

Avalanche energy is measured at $V_{DD} = 99 V$,
 $L = 20 mH$, $I_L = 2.5 A$.

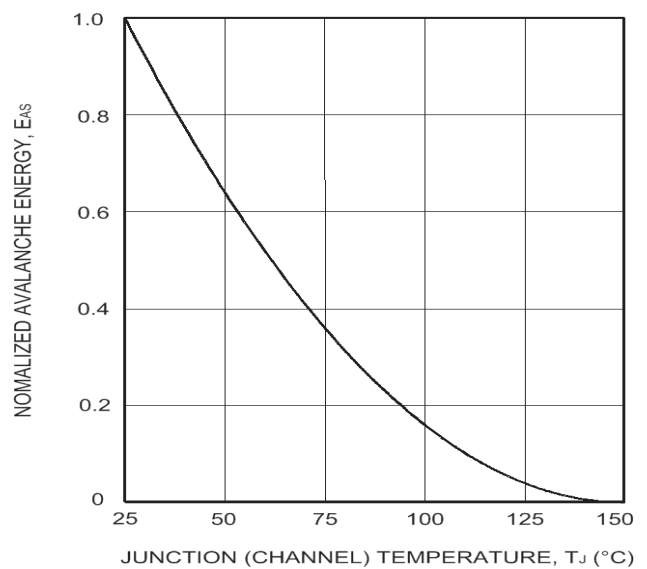
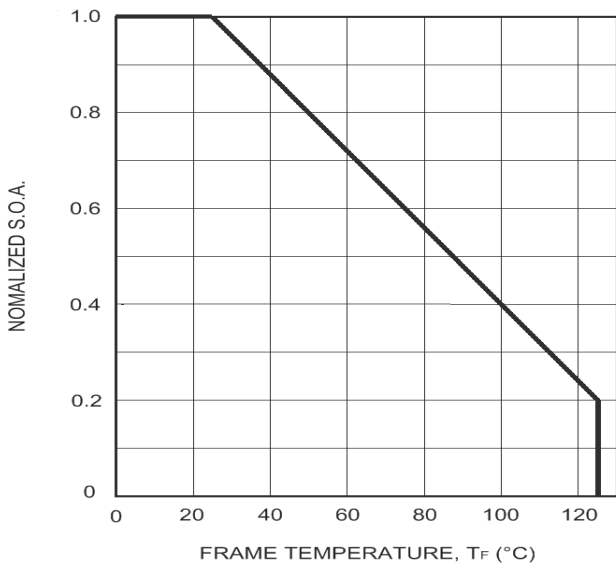

MOSFET TYPICAL CHARACTERISTICS (cont'd)

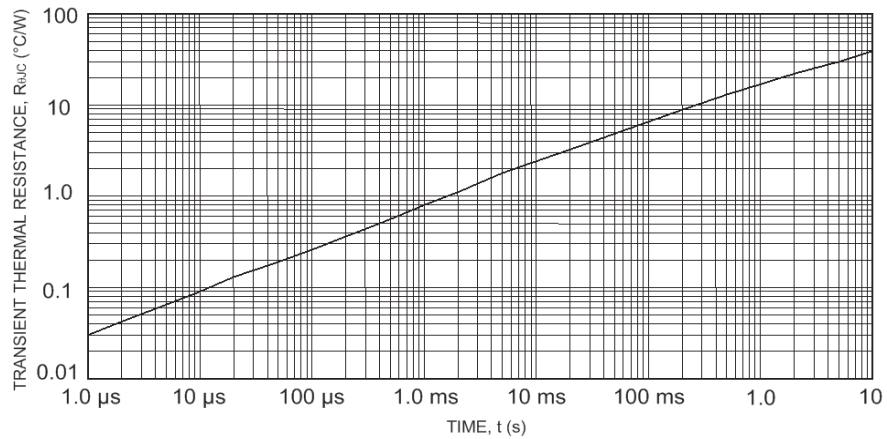

WARNING — These devices are designed to be operated at lethal voltages and energy levels. Circuit designs that embody these components must conform with applicable safety requirements. Precautions must be taken to prevent accidental contact with power-line potentials. Do not connect grounded test equipment.

The use of an isolation transformer is recommended during circuit development and breadboarding.

STR-A6251M
Universal-Input/15 W
67 kHz Flyback Switching Regulator

**Switching
Regulators**

APPLICATIONS INFORMATION

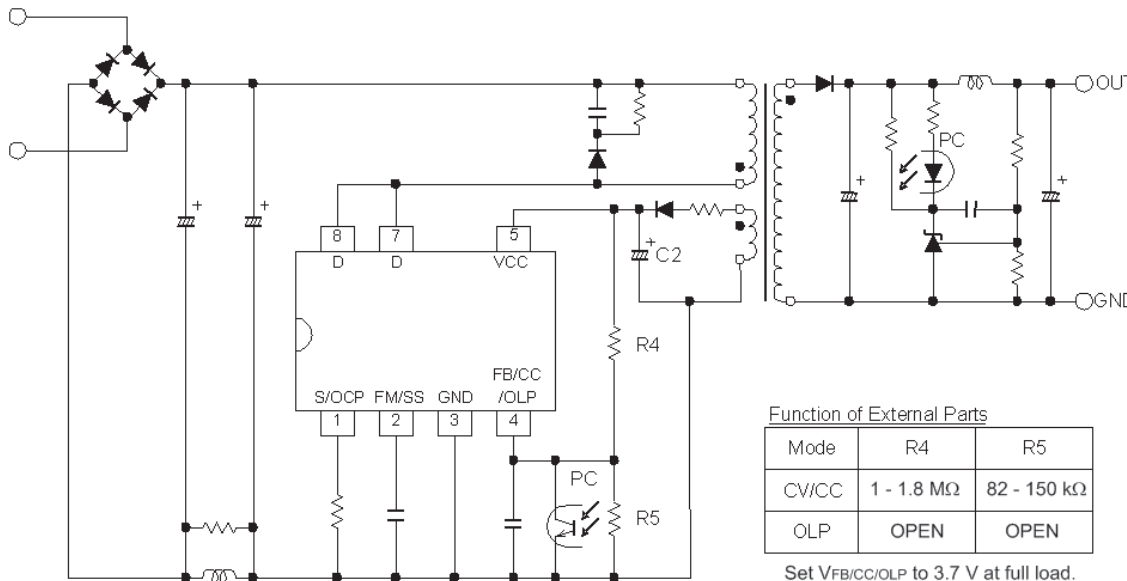

Typical Application

NOTE: The start-up performance of the IC can only be guaranteed for values of C2 greater than 22 μF. This value is required to keep the internal supply voltage within regulation during IC initialization.

Complete product description and applications information is provided in Application Note 28103.40, *Series STR-A6200 Flyback Switching Regulators*.

The products described herein are manufactured in Japan by Sanken Electric Co., Ltd. for sale by Allegro MicroSystems, Inc.

Sanken and Allegro reserve the right to make, from time to time, such departures from the detail specifications as may be required to permit improvements in the performance, reliability, or manufacturability of its products. Therefore, the user is cautioned to verify that the information in this publication is current before placing any order.

When using the products described herein, the applicability and suitability of such products for the intended purpose shall be reviewed at the users responsibility.

Although Sanken undertakes to enhance the quality and reliability of its products, the occurrence of failure and defect of semiconductor products at a certain rate is inevitable.

Users of Sanken products are requested to take, at their own risk, preventative measures including safety design of the equipment or systems against any possible injury, death, fires or damages to society due to device failure or malfunction.

Sanken products listed in this publication are designed and intended for use as components in general-purpose electronic equipment or apparatus (home appliances, office equipment, telecommunication equipment, measuring equipment, etc.). Their use in any application requiring radiation hardness assurance (e.g., aerospace equipment) is not supported.

When considering the use of Sanken products in applications where higher reliability is required (transportation equipment and its control systems or equipment, fire- or burglar-alarm systems, various safety devices, etc.), contact a company sales representative to discuss and obtain written confirmation of your specifications.

The use of Sanken products without the written consent of Sanken in applications where extremely high reliability is required (aerospace equipment, nuclear power-control stations, life-support systems, etc.) is strictly prohibited.

The information included herein is believed to be accurate and reliable. Application and operation examples described in this publication are given for reference only and Sanken and Allegro assume no responsibility for any infringement of industrial property rights, intellectual property rights, or any other rights of Sanken or Allegro or any third party that may result from its use.

PACKAGE DIMENSIONS

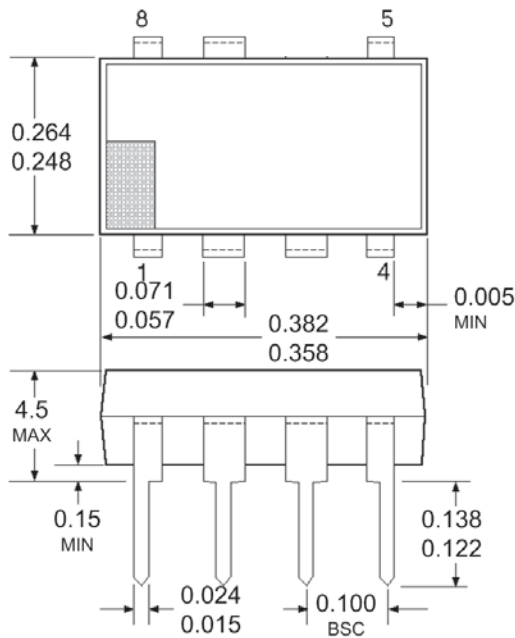

Dimensions in Inches
(for reference only)

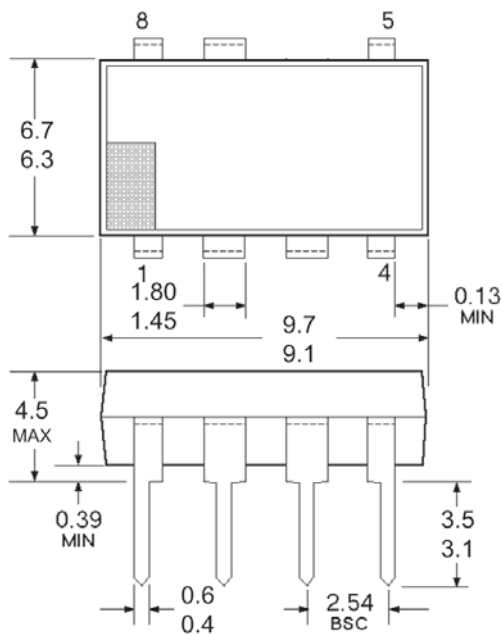

Dimensions in Millimeters
(controlling dimensions)

Terminal Finish: Pure Sn, 2nd level interconnect category (e3).
Product Weight: Approx. 0.51 g.
Frame temperature, T_F , is measured at the root of pin 3.
For more efficient heat radiation, connect a broad PCB pattern at pins 7 and 8.

Компания «Life Electronics» занимается поставками электронных компонентов импортного и отечественного производства от производителей и со складов крупных дистрибьюторов Европы, Америки и Азии.

С конца 2013 года компания активно расширяет линейку поставок компонентов по направлению коаксиальный кабель, кварцевые генераторы и конденсаторы (керамические, пленочные, электролитические), за счёт заключения дистрибьюторских договоров

Мы предлагаем:

- Конкурентоспособные цены и скидки постоянным клиентам.
- Специальные условия для постоянных клиентов.
- Подбор аналогов.
- Поставку компонентов в любых объемах, удовлетворяющих вашим потребностям.
- Приемлемые сроки поставки, возможна ускоренная поставка.
- Доставку товара в любую точку России и стран СНГ.
- Комплексную поставку.
- Работу по проектам и поставку образцов.
- Формирование склада под заказчика.
- Сертификаты соответствия на поставляемую продукцию (по желанию клиента).
- Тестирование поставляемой продукции.
- Поставку компонентов, требующих военную и космическую приемку.
- Входной контроль качества.
- Наличие сертификата ISO.

В составе нашей компании организован Конструкторский отдел, призванный помогать разработчикам, и инженерам.

Конструкторский отдел помогает осуществить:

- Регистрацию проекта у производителя компонентов.
- Техническую поддержку проекта.
- Защиту от снятия компонента с производства.
- Оценку стоимости проекта по компонентам.
- Изготовление тестовой платы монтаж и пусконаладочные работы.



Тел: +7 (812) 336 43 04 (многоканальный)

Email: org@lifeelectronics.ru