

DP3T SECTION

SECTION 3

Pages

RAMSES series.....

 DP3T and Terminated SPDT up to 40 GHz: **R585 Series** 3-2 to 3-5

Electrical Schematics.....

 R585 Series..... 3-6 to 3-11

PLATINUM Series.....

 High performances DP3T & Terminated SPDT up to 26.5 GHz: **R595 Series** 3-12 to 3-21

OPTIONAL FEATURES 3-22

DP3T PRODUCTS SELECTION GUIDE

Quick access to the right page:

Connector	Frequency				
	DC - 3	DC - 6	DC - 18	DC - 26.5	DC - 40
SMA				3-2 / 3-12	
SMA2.9					3-2

For more detailed technical information please consult Radiall customer support.



Radiall's RAMSES DP3T and Terminated SPDT switches offer excellent reliability, high performance and operating frequencies from DC to 40 GHz. A full range of options are available with RADIALL RAMSES concept to offer customers complete solutions.

These relays are dedicated to market applications including: Defense Instrumentation and Telecommunications.

Example of P/N:

R585423300 is a SPDT terminated SMA 18GHz, failsafe, 28Vdc, indicator contacts, internal terminations without TTL drivers and solder pins.

PART NUMBER SELECTION

R 585

RF Connectors:

- 3: SMA up to 3 GHz
- 4: SMA up to 18 GHz
- F: SMA up to 26.5 GHz
- 8: SMA2.9 up to 40 GHz (4) (5)

Type:

- 1: Failsafe
- 2: Failsafe + I.C.
- 3: Latching
- 4: Latching + I.C.
- 5: Latching + S.C.O. (1)
- 6: Latching + S.C.O + I.C. (1)
- 7: Normally open
- 8: Normally open + I.C.

I.C.: Indicator contact - S.C.O.: Self Cut-Off

- (1): Suppression diodes are already included in Self Cut-OFF & TTL option
- (2): Polarity is not relevant to application for switches with TTL driver
- (3): Positive common shall be specified only with type 3, 4, 5, 6, 7 & 8 because failsafe switches can be used with both polarities
- (4): Not available with switch model "2" & "3"

Actuator Terminals:

- 0: Solder pins

Options:

- 0: Without option
- 1: Positive common (2) (3)
- 3: With suppression diodes (1)
- 4: With suppression diodes and positive common (2) (3)

Switch Model:

- 0: DP3T without TTL Driver (DP3T)
- 1: DP3T with TTL Driver (DP3T) (high level) (1) (2)
- 2: SPDT terminated without TTL Driver / (internal termination)
- 3: SPDT terminated without TTL Driver / (high level) (1) (2) / (internal termination)
- 4: SPDT terminated without TTL Driver / (external termination)
- 5: SPDT terminated with TTL Driver / (high level) (1) (2) / (external termination)
- 6: Terminated 4 ports bypass no option (external terminations)
- 7: Terminated 4 ports bypass with TTL (external termination)

Actuator Voltage:

- 2: 12 Vdc
- 3: 28 Vdc

(5): Connector SMA2.9 is equivalent to "K connector", registered trademark of Anritsu.

To download technical data sheets, visit www.radiall.com & enter the part number in the Search box. For more detailed technical information please consult Radiall customer support.

GENERAL SPECIFICATIONS

Operating mode		Failsafe		Latching		Normally open	
Nominal operating voltage (across operating temperature)	Vdc	12	28	12	28	12	28
		(10.2 to 13)	(24 to 30)	(10.2 to 13)	(24 to 30)	(10.2 to 13)	(24 to 32)
Coil resistance (+/-10%)	Ω	24	138	29	175	47.5	275
Nominal operating current at 23°C	mA	500	205	420	160	250	102
Average power		RF path: see power rating chart page 1-16 Internal terminations: 1 Watt CW into 50 Ohms					
TTL Input	High level	2.5 to 5.5 Volts		800µA max 5.5 Volts			
	Low level	0 to 0.8 Volts		20µA max 0.8 Volts			
Switching time (max)	ms	10					
Life (min)		2 million cycles for products with internal terminations and 40 GHz models 10 million cycles for all other products					
Connectors		SMA - SMA2.9					
Actuator terminals		Solder pins					
Operating temperature range	SMA SMA2.9	-40°C, +85°C					
Storage temperature range	SMA SMA2.9	-55°C, +85°C					
Vibration (MIL STD 202, Method 204D, cond.D)		10-2000 Hz, 20g				Operating	
Shock (MIL STD 202, Method 213B, cond.C)		100g / 6ms, ½ sine				Operating	

RF PERFORMANCES

Connectors	Frequency Range GHz	V.S.W.R. (max)	Insertion Loss (max) dB	Isolation (min) dB	Impedance Ohms	
SMA	DC - 3 DC - 18 DC - 26.5	DC - 3	1.20	0.20	80	50
		3 - 8	1.30	0.30	70	
		8 - 12.4	1.40	0.40	60	
		12.4 - 18	1.50	0.50	60	
		18 - 26.5	1.80	0.70	50	
SMA2.9	DC - 40	DC - 6	1.30	0.30	70	50
		6 - 12.4	1.40	0.40	60	
		12.4 - 18	1.50	0.50	60	
		18 - 26.5	1.70	0.70	55	
		26.5 - 40	1.90	0.80	50	

See page 3-4 for typical RF performances

To download technical data sheets, visit www.radiall.com & enter the part number in the Search box.
For more detailed technical information please consult Radiall customer support.

R585 TYPICAL RF PERFORMANCES

Example: DP3T SMA up to 26.5 GHz



Example: DP3T SMA2.9 up to 40 GHz



ACCESSORIES

A printed circuit board interface connector (ordered separately) has been designed for easy mounting on terminals.

For DP3T model R585 series => Radiall part number: **R599910000**

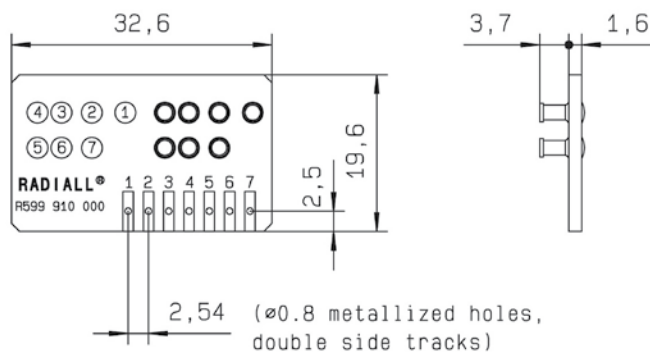

To download technical data sheets, visit www.radiall.com & enter the part number in the Search box.
For more detailed technical information please consult Radiall customer support.

TYPICAL OUTLINE DRAWING

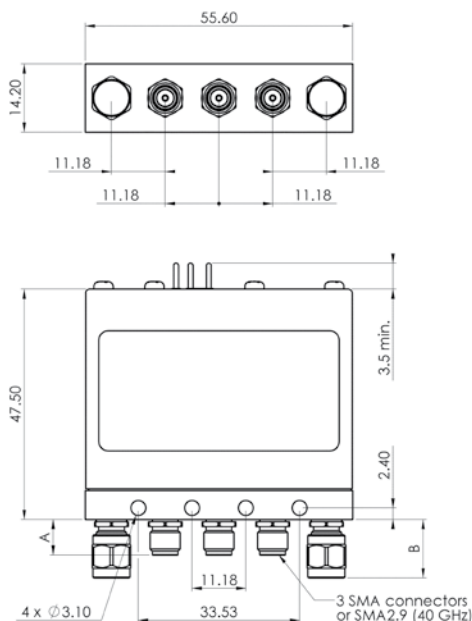

SPDT with external terminations
R585 --- 4--
R585 --- 5--



SPDT with internal terminations
R585 --- 2--
R585 --- 3--

See page
3-11
for pin
identification



DP3T
R585---0--
R585---1--



Terminated 4 ports BYPASS relay
R585 --- 6--
R585 --- 7--

Connectors	A (mm)	B max (mm) If applicable
SMA up to 18 GHz	7.4	13.5
SMA up to 26.5 GHz	7.4	21
SMA 2.9 up to 40 GHz	6.3	21

To download technical data sheets, visit www.radiall.com & enter the part number in the Search box.
For more detailed technical information please consult Radiall customer support.

FAILSAFE

WITHOUT OPTION
R585 -1- 000 / R585 -1- 200 / R585 -1- 400

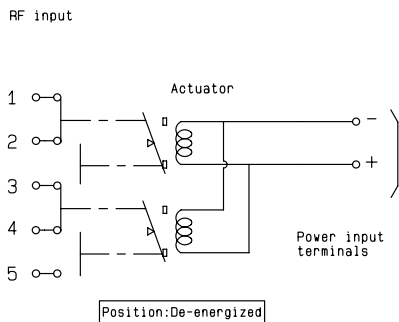

WITH INDICATOR CONTACT
R585 -2- 000 / R585 -2- 200 / R585 -2- 400

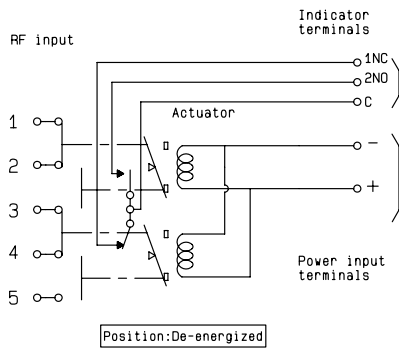

WITH SUPPRESSION DIODES
R585 -1- 030 / R585 -1- 230 / R585 -1- 430

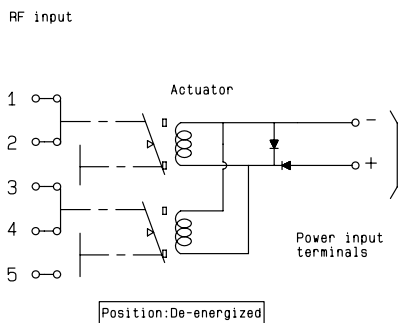

WITH SUPPRESSION DIODES AND INDICATOR CONTACT
R585 -2- 030 / R585 -2- 230 / R585 -2- 430

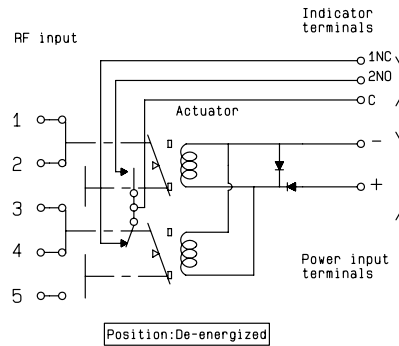

WITH TTL DRIVER
(suppression diodes are included)
R585 -1- 100 / R585 -1- 300 / R585 -1- 500

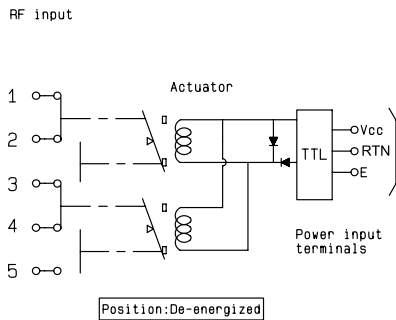

WITH TTL DRIVER AND INDICATOR CONTACT
(suppression diodes are included)
R585 -2- 100 / R585 -2- 300 / R585 -2- 500

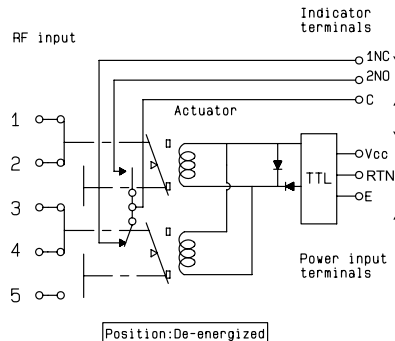

To download technical data sheets, visit www.radiall.com & enter the part number in the Search box.
For more detailed technical information please consult Radiall customer support.

NORMALLY OPEN

<p>WITHOUT OPTION R585 -7- 000 / R585 -7- 200 / R585 -7- 400</p>	<p>WITH INDICATOR CONTACT R585 -8- 000 / R585 -8- 200 / R585 -8- 400</p>
<p>WITH SUPPRESSION DIODES R585 -7- 030 / R585 -7- 230 / R585 -7- 430</p>	<p>WITH SUPPRESSION DIODES AND INDICATOR CONTACT R585 -8- 030 / R585 -8- 230 / R585 -8- 430</p>
<p>WITH TTL DRIVER (suppression diodes are included) R585 -7- 100 / R585 -7- 300 / R585 -7- 500</p>	<p>WITH TTL DRIVER AND INDICATOR CONTACT (suppression diodes are included) R585 -8- 100 / R585 -8- 300 / R585 -8- 500</p>

To download technical data sheets, visit www.radiall.com & enter the part number in the Search box.
For more detailed technical information please consult Radiall customer support.

NORMALLY OPEN

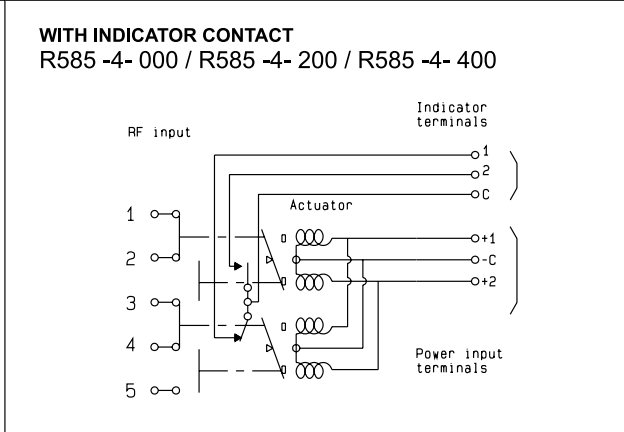
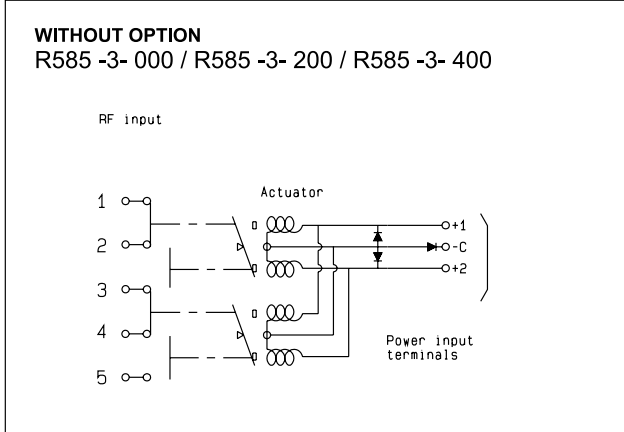
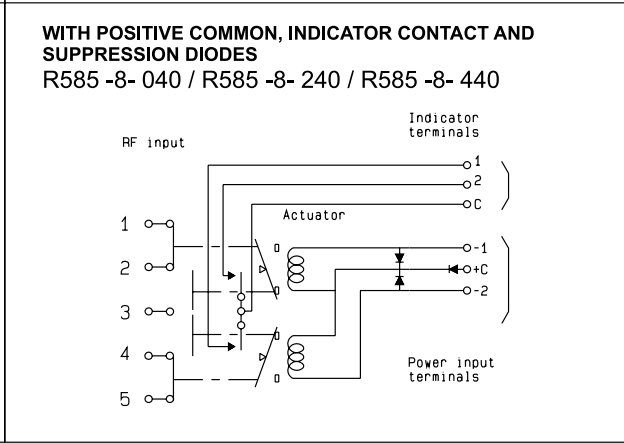
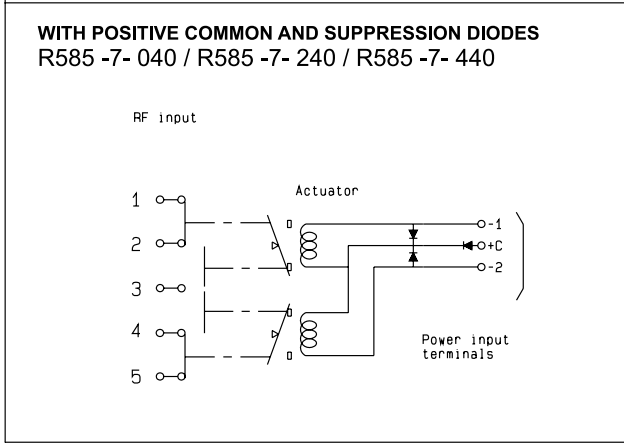
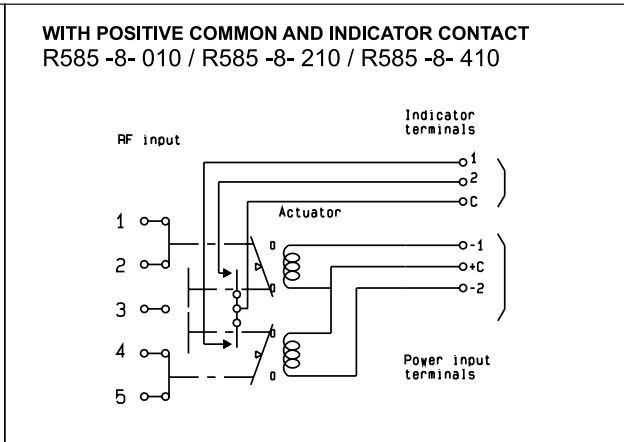
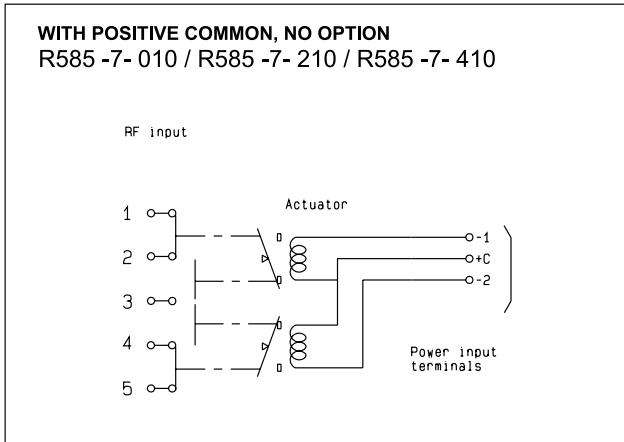

DP3T

To download technical data sheets, visit www.radiall.com & enter the part number in the Search box.
For more detailed technical information please consult Radiall customer support.

LATCHING

WITH SUPPRESSION DIODES
R585 -3- 030 / R585 -3- 230 / R585 -3- 430



WITH SUPPRESSION DIODES AND INDICATOR CONTACT
R585 -4- 030 / R585 -4- 230 / R585 -4- 430



WITH TTL DRIVER
(suppression diodes are included)
R585 -3- 100 / R585 -3- 300 / R585 -3- 500



WITH TTL DRIVER AND INDICATOR CONTACT
(suppression diodes are included)
R585 -4- 100 / R585 -4- 300 / R585 -4- 500



WITH CUT-OFF
(suppression diodes are included)
R585 -5- 000 / R585 -5- 200 / R585 -5- 400



WITH CUT-OFF AND INDICATOR CONTACT
(suppression diodes are included)
R585 -6- 000 / R585 -6- 200 / R585 -6- 400



To download technical data sheets, visit www.radiall.com & enter the part number in the Search box.
For more detailed technical information please consult Radiall customer support.

LATCHING

WITH CUT-OFF AND TTL DRIVER
(suppression diodes are included)
R585 -5- 100 / R585 -5- 300 / R585 -5- 500

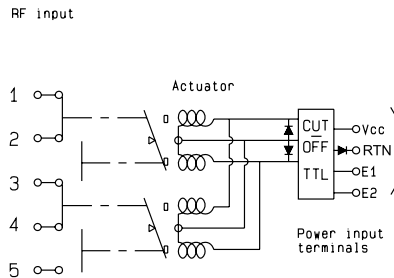

WITH CUT-OFF, TTL DRIVER AND INDICATOR CONTACT
(suppression diodes are included)
R585 -6- 100 / R585 -6- 300 / R585 -6- 500

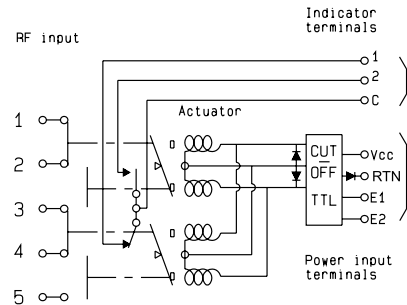

WITH POSITIVE COMMON, NO OPTION
R585 -3- 010 / R585 -3- 210 / R585 -3- 410

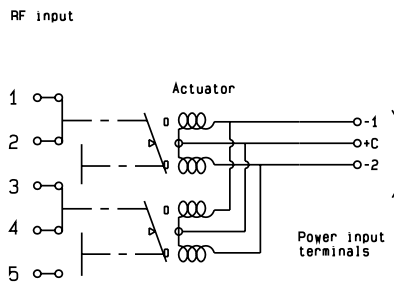

WITH POSITIVE COMMON AND INDICATOR CONTACT
R585 -4- 010 / R585 -4- 210 / R585 -4- 410

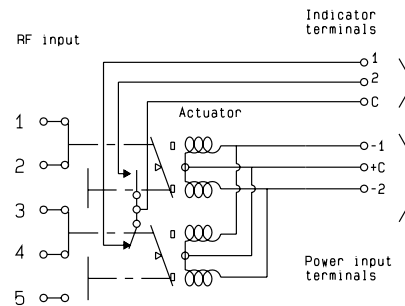

WITH POSITIVE COMMON AND SUPPRESSION DIODES
R585 -3- 040 / R585 -3- 240 / R585 -3- 440



WITH POSITIVE COMMON, SUPPRESSION DIODES AND INDICATOR CONTACT
R585 -4- 040 / R585 -4- 240 / R585 -4- 440

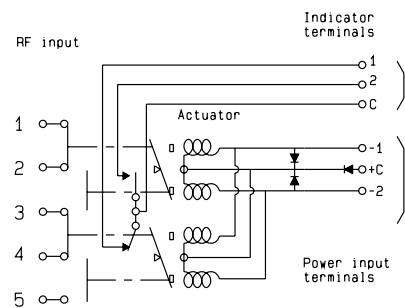

To download technical data sheets, visit www.radiall.com & enter the part number in the Search box.
For more detailed technical information please consult Radiall customer support.

LATCHING

WITH POSITIVE COMMON AND CUT-OFF
(suppression diodes are included)
R585 -5- 010 / R585 -5- 210 / R585 -5- 410

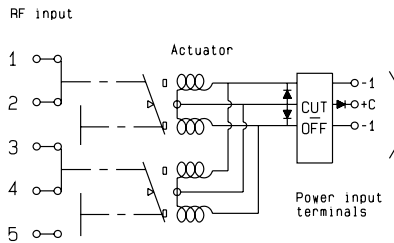

WITH POSITIVE COMMON, CUT-OFF AND INDICATOR CONTACT
(suppression diodes are included)
R585 -6- 010 / R585 -6- 210 / R585 -6- 410

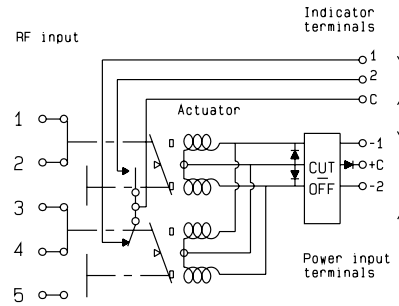

PIN IDENTIFICATION

Type	PIN							
	1	2	3	4	5	6	7	8
Failsafe	+		-					
Failsafe + I.C.	+		-		2NO	1NC	C	
Failsafe + TTL	E		RTN	VCC				
Failsafe + I.C. + TTL	E		RTN	VCC	2NO	1NC	C	
Latching	-2 or +2	-1 or +1	+C or -C					
Latching + I.C.	-2 or +2	-1 or +1	+C or -C		2	1	C	
Latching + TTL	E2	E1	RTN	VCC				
Latching + I.C.	E2	E1	RTN	VCC	2	1	C	
Latching + TTL + I.C. + Cut-off	E2	E1	RTN	VCC	2	1	C	
Normally open	-2	-1	+C					
Normally open + I.C.	-2	-1	+C					
Normally open + TTL	E2	E1	RTN	VCC				
Normally open + TTL + I.C.	E2	E1	RTN	VCC	2	1	C	

Bottom view

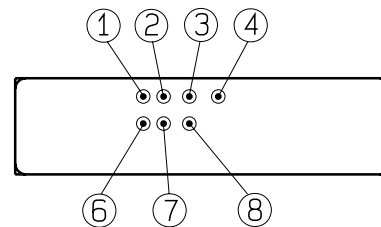

To download technical data sheets, visit www.radiall.com & enter the part number in the Search box.
For more detailed technical information please consult Radiall customer support.



Radiall's PLATINUM series switches are optimised to perform at a high level over an extended life span. With outstanding RF performances, and a guaranteed Insertion Loss repeatability of 0.03 dB over a life span of 10 million switching cycles. PLATINUM SERIES switches are perfect for automated test and measurement equipment, as well as signal monitoring devices.

Example of P/N:

R595F63215 is a Terminated SPDT SMA 26.5 GHz, latching with Self Cut-Off, 24Vdc, Indicators, D-Sub connector.

PART NUMBER SELECTION

R 595

RF Connectors:

- 3: SMA up to 6 GHz
- 4: SMA up to 20 GHz
- F: SMA up to 26.5 GHz

Type:

- 3: Latching
- 4: Latching + I.C.
- 5: Latching + S.C.O.
- 6: Latching + S.C.O. + I.C.

Actuator Voltage:

- 3: 24 Vdc
- 7: 15 Vdc

Switch Model:

- 2: Terminated SPDT switch
- 3: Terminated 4 ports bypass switch
- 4: Non terminated 5 ports DP3T switch

Documentation:

- : Certificate of conformity
- C: Calibration certificate
- R: Calibration certificate + RF curves

Actuator Termination:

- 0: Solder pins
- 5: D-Sub connector

Options:

- 1: Without option (positive common)
- 2: Compatible TTL driver (high level)

To download technical data sheets, visit www.radiall.com & enter the part number in the Search box. For more detailed technical information please consult Radiall customer support.

GENERAL SPECIFICATIONS

Operating mode		Latching	
Nominal operating voltage (across operating temperature)	Vdc	24 (20 to 32)	15 (12 to 20)
Coil resistance (+/-10%)	Ω	175	60
Operating current at 23°C	mA	140	250
Average Power		RF Path	Cold switching: see Power Chart on page 3-21 Hot switching: 1 Watt CW
		Internal terminations	1 Watt average into 50 Ohms
TTL input	High level	3 to 7 Volts: 800 μ A max at 7 Volts	
	Low level	0 to 0.8 Volts: 20 μ A max at 0.8 Volts	
Switching time (max)	ms	15	
Life (min)		10 million cycles	
Connectors		SMA	
Actuator terminal		D-Sub 9 pin female Solder pins	
Weight	g	100	

ENVIRONMENTAL SPECIFICATIONS

Operating temperature range	-25°C to +75°C
Storage temperature range	-55°C to +85°C
Temperature cycling (MIL STD 202F, Method 107D, Cond.A)	-55°C to +85°C (10 cycles)
Sine vibration operating (MIL STD 202, Method 204D, Cond.D)	10-2000 Hz, 20g
Random vibration operating	16.91g (rms) 50-2000 Hz 3min/axis
Shock operating (MIL STD 202, Method 213B, Cond.G)	50g / 11ms, sawtooth
Humidity operating	15 to 95% relative humidity
Humidity storage (MIL STD 202, Method 106E, Cond.E)	65°C, 95% RH, 10 days
Altitude operating	15,000 feet (4,600 meters)
Altitude storage (MIL STD 202, Method 105C, Cond.B)	50,000 feet (15,240 meters)

To download technical data sheets, visit www.radiall.com & enter the part number in the Search box.
For more detailed technical information please consult Radiall customer support.

RF PERFORMANCES

Part Number		R5953-----	R5954-----	R595F-----	
Frequency range	GHz	DC to 6	DC to 20	DC to 26.5	
Impedance	Ω	50			
Insertion Loss (max)	dB	0.20 + (0.45 / 26.5) x frequency (GHz)			
Isolation (min)	85	DC to 6 GHz	85	DC to 6 GHz	85
		6 to 12.4 GHz	75	6 to 12.4 GHz	75
		12.4 to 20 GHz	65	12.4 to 20 GHz	65
20 to 26.5 GHz	60				
V.S.W.R. (max)	1.15	DC to 6 GHz	1.15	DC to 6 GHz	1.15
		6 to 12.4 GHz	1.25	6 to 12.4 GHz	1.25
		12.4 to 18 GHz	1.30	12.4 to 18 GHz	1.30
		18 to 20 GHz	1.60	18 to 26.5 GHz	1.60
Repeatability (up to 10 million cycles mesured at 25°C)		0.03 dB maximun			

TYPICAL RF PERFORMANCES

Insertion Loss and Isolation



V.S.W.R.

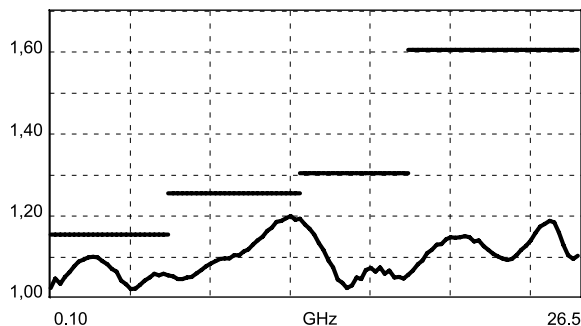

To download technical data sheets, visit www.radiall.com & enter the part number in the Search box.
For more detailed technical information please consult Radiall customer support.

SWITCH MODEL: TERMINATED SPDT SWITCH

The terminated SPDT switch is a single pole double throw switch. The unused ports are terminated into 50 ohms. This switch is "break before make".

RF SCHEMATIC DIAGRAM



POSITION INDICATORS

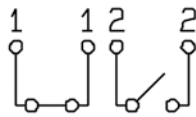

STATE "11"

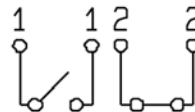

STATE "22"

Standard drive option "1" (Positive common):

- Connect pin +Vcc to supply (+20 Vdc to +32 Vdc).
- Select desired RF path by applying ground to the corresponding "close" pin (Ex: ground pin E1 to switch to position E1. RF path 1-2 closed and RF path 2-3 open).
- To open desired path and close the new RF path, connect ground to the corresponding "close" pin (Ex: ground pin E2 to open RF path 1-2 and close RF path 2-3).

TTL drive option "2"

- Connect pin RTN to ground.
- Connect pin +Vcc to supply (+20 Vdc to +32 Vdc)
- Select (close) desired RF path by applying TTL "High" to the corresponding "drive" pin. (Ex: apply TTL "High" to pin E1 to switch to position E1. RF path 1-2 closed and RF path 2-3 open).
- To open desired path and close the new RF path, apply TTL "High" to the "drive" pin which corresponds to the desired RF path. (Ex: apply TTL "High" to pin E2 to open RF path 1-2 and close RF path 2-3).

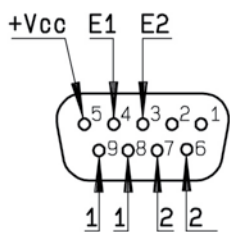

D-Sub connector

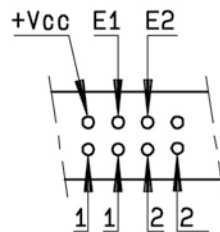

Solder pins

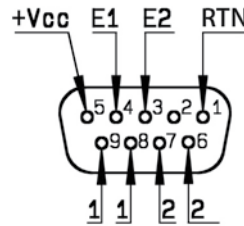

D-Sub connector

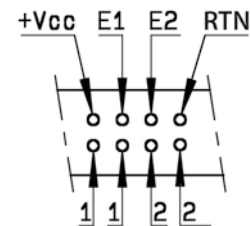

Solder pins

To download technical data sheets, visit www.radiall.com & enter the part number in the Search box. For more detailed technical information please consult Radiall customer support.

SWITCH MODEL: TERMINATED SPDT SWITCH

With D-Sub connector



With solder pins

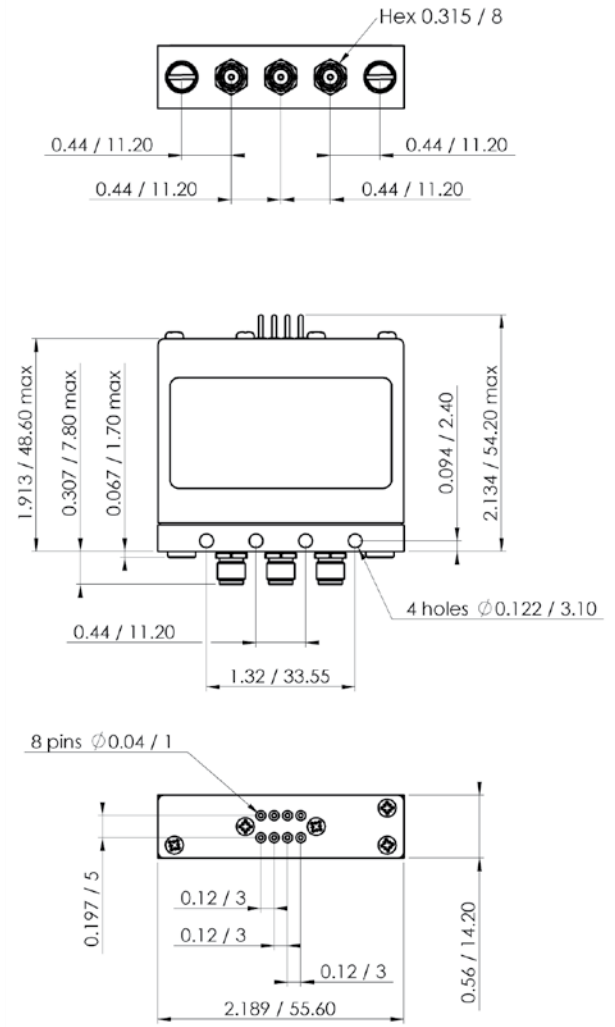

All dimensions are in inches/millimeters

To download technical data sheets, visit www.radiall.com & enter the part number in the Search box.
For more detailed technical information please consult Radiall customer support.

SWITCH MODEL: TERMINATED 4 PORT BYPASS SWITCH

The terminated 4 port bypass switch can terminate into the 50 ohms device under test. These switches are “break before make”.

RF SCHEMATIC DIAGRAM



POSITION INDICATORS

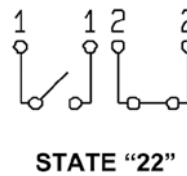
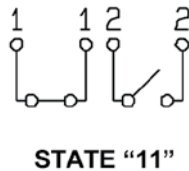

Standard drive option "1" (Positive common):

- Connect pin +Vcc to supply (+20 Vdc to +32 Vdc).
- Select desired RF path by applying ground to the corresponding "close" pin (Ex: ground pin E1 to switch to position E1. RF path 1-2 and RF path 3-4 closed and RF path 2-3 open).
- To open desired path and close the new RF path, connect ground to the corresponding "close" pin (Ex: ground pin E2 to open RF path 1-2 and 3-4 and close RF path 2-3).

TTL drive option "2":

- Connect pin RTN to ground.
- Connect pin +Vcc to supply (+20 Vdc to +32 Vdc).
- Select (close) desired RF path by applying TTL "High" to the corresponding "drive" pin (Ex: apply TTL "High" to pin E1 to switch to position E1. RF path 1-2 and 3-4 closed and RF path 2-3 open).
- To open desired path and close the new RF path, apply TTL "High" to the "drive" pin which corresponds to the desired RF path. (Ex: apply TTL "High" to pin E2 to open RF path 1-2 and 3-4 and close RF path 2-3).

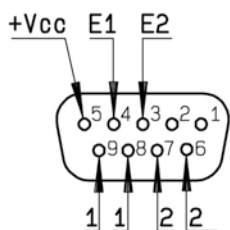

D-Sub connector



Solder pins

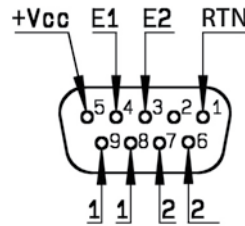

D-Sub connector

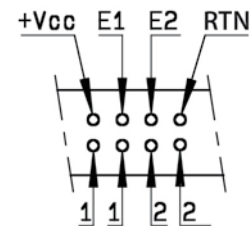

Solder pins

To download technical data sheets, visit www.radiall.com & enter the part number in the Search box. For more detailed technical information please consult Radiall customer support.

SWITCH MODEL: TERMINATED 4 PORT BYPASS SWITCH

With D-Sub connector

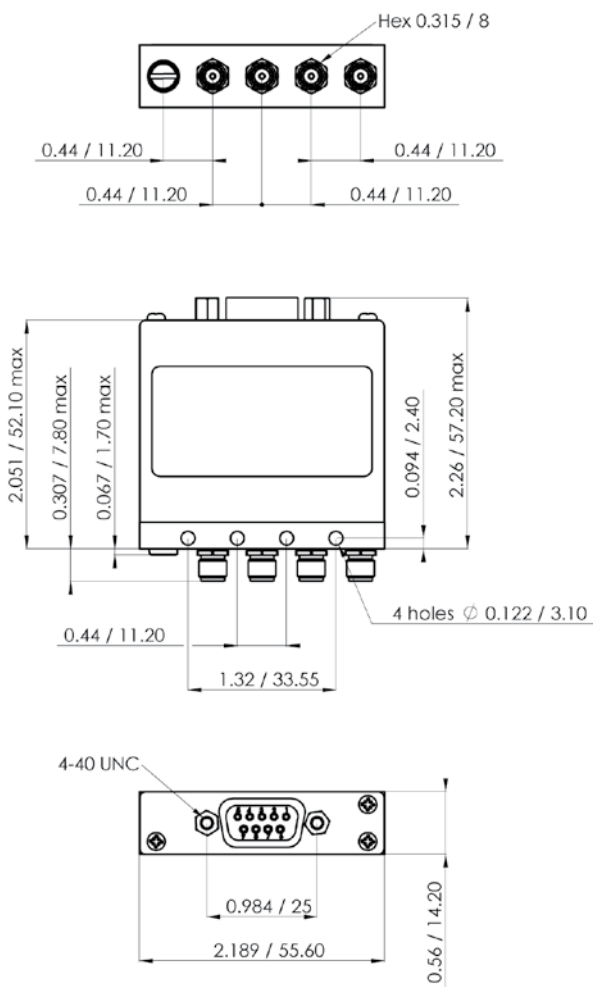

With solder pins

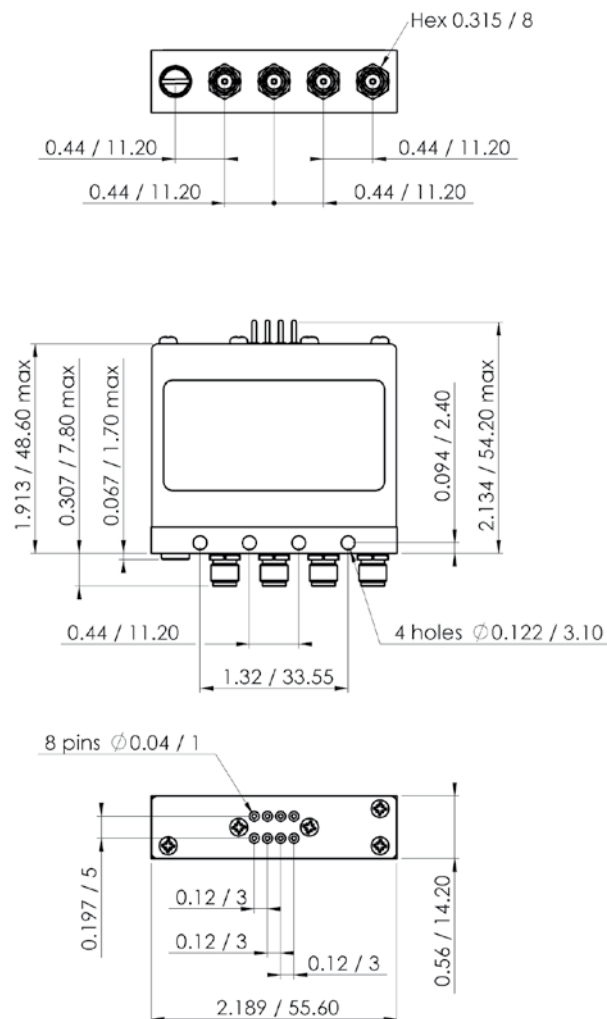

All dimensions are in inches/millimeters

To download technical data sheets, visit www.radiall.com & enter the part number in the Search box. For more detailed technical information please consult Radiall customer support.

SWITCH MODEL: 5 PORT DP3T SWITCH

The non terminated 5 port DP3T switch can be used as SPDT with high power terminations, as a bypass switch. In this application, the fifth port can be terminated externally with a high power termination. These switches are "break before make".

RF SCHEMATIC DIAGRAM



POSITION INDICATORS



Standard drive option "1" (Positive common):

- Connect pin +Vcc to supply (+20 Vdc to +32 Vdc).
- Select desired RF path by applying ground to the corresponding "close" pin (Ex: ground pin E1 to switch to position E1. RF path 2-3 and RF path 4-5 closed and RF path 1-2 and RF path 3-4 open).
- To open desired path and close the new RF path, connect ground to the corresponding "close" pin (Ex: ground pin E2 to open RF path 2-3 and 4-5 and close RF path 1-2 and 3-4).

TTL drive option "2":

- Connect pin RTN to ground.
- Connect pin +Vcc to supply (+20 Vdc to +32 Vdc)
- Select (close) desired RF path by applying TTL "High" to the corresponding "drive" pin (Ex: apply TTL "High" to pin E1 to switch to position E1. RF path 2-3 and RF path 4-5 closed and RF path 1-2 and 3-4 open).
- To open desired path and close the new RF path, apply TTL "High" to the "drive" pin which corresponds to the desired RF path. (Ex: apply TTL "High" to pin E2 to open RF path 2-3 and 4-5 and close RF path 1-2 and 3-4).



To download technical data sheets, visit www.radiall.com & enter the part number in the Search box. For more detailed technical information please consult Radiall customer support.

SWITCH MODEL: 5 PORT DP3T SWITCH

With D-Sub connector

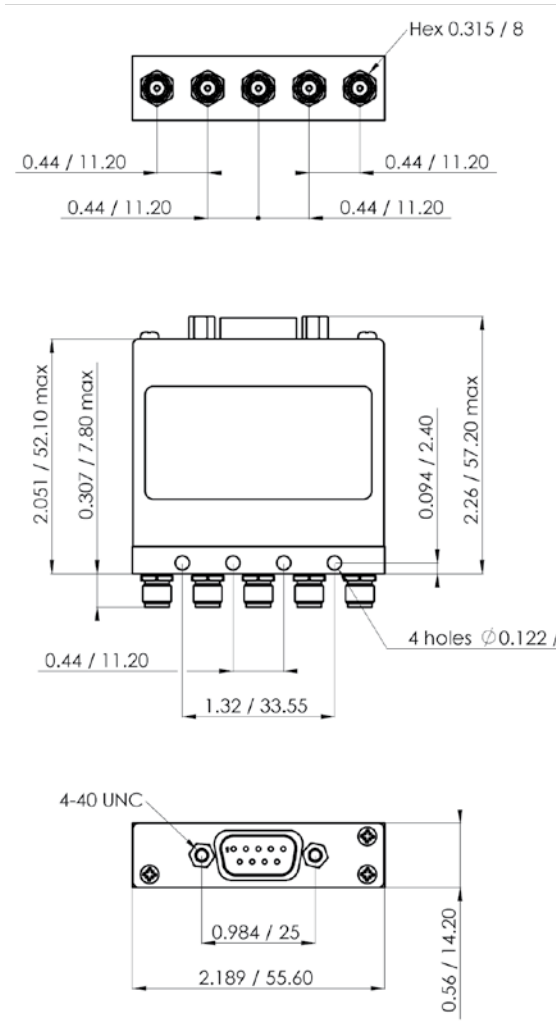

With solder pins

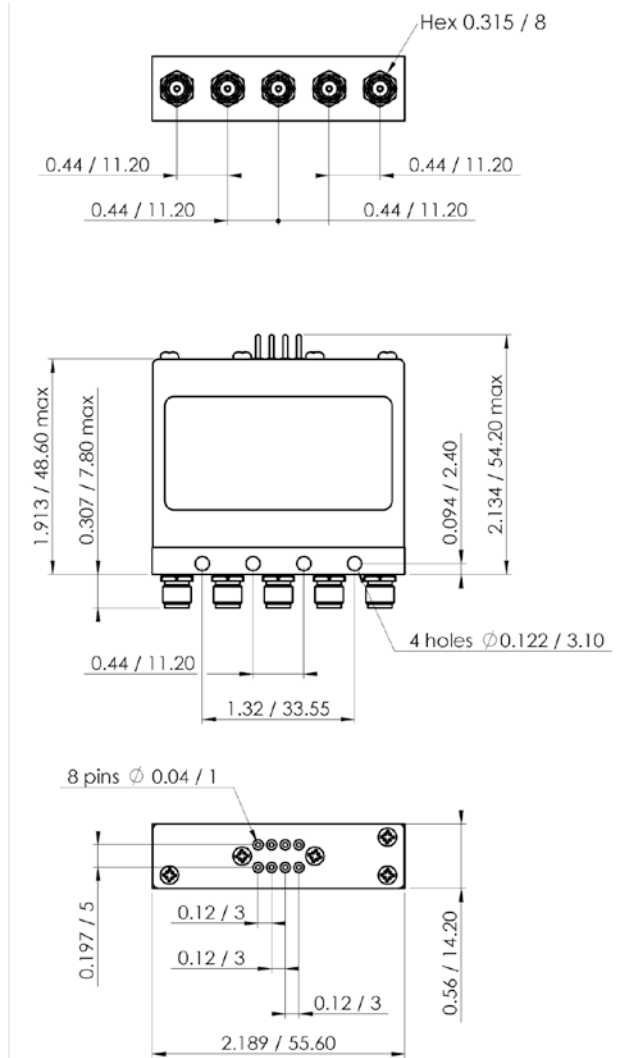

All dimensions are in inches/millimeters

To download technical data sheets, visit www.radiall.com & enter the part number in the Search box. For more detailed technical information please consult Radiall customer support.

POWER RATING CHART

This graph is based on the following conditions:

- Ambient temperature: + 25°C
- Sea level
- V.S.W.R.: 1 and cold switching

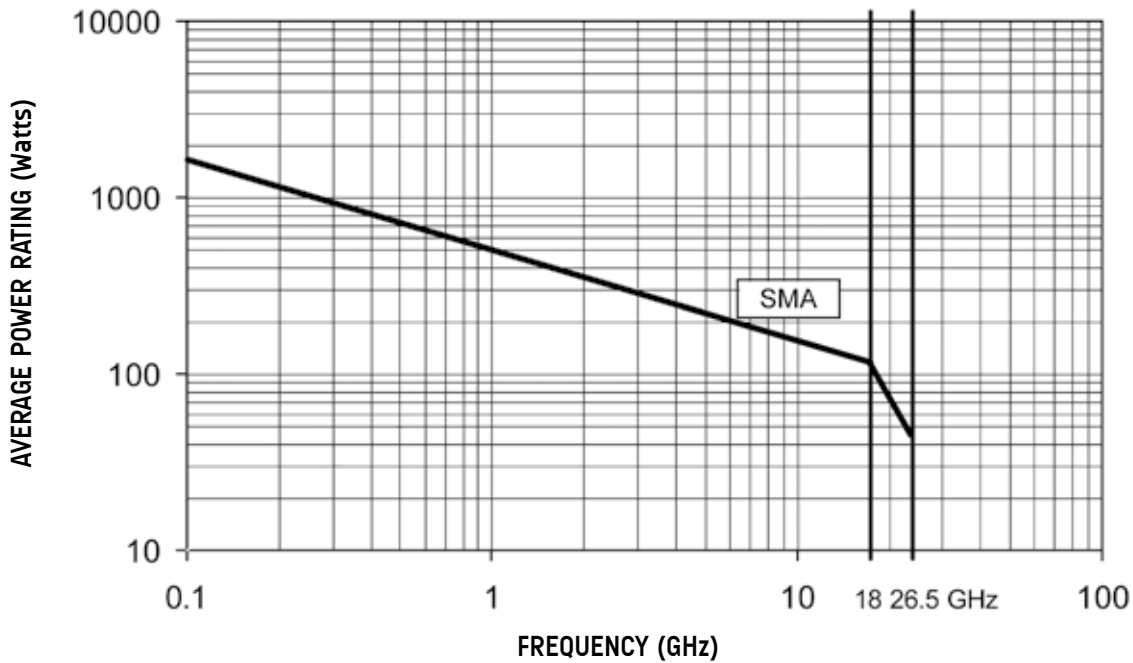

DERATING FACTOR VERSUS V.S.W.R.

The average power input must be reduced for load V.S.W.R. above 1.1

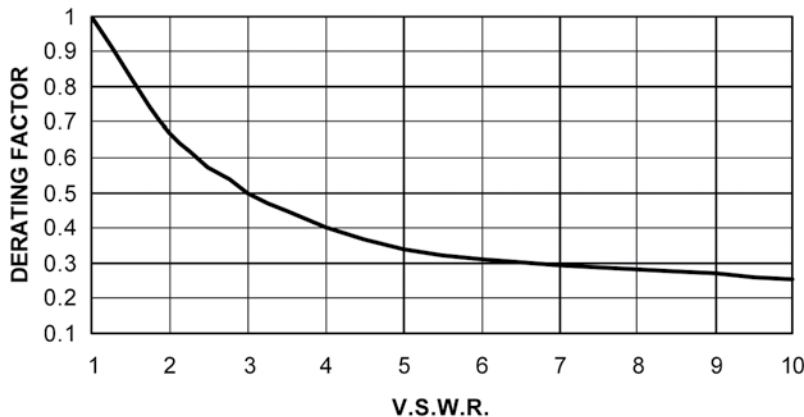

To download technical data sheets, visit www.radiall.com & enter the part number in the Search box.
For more detailed technical information please consult Radiall customer support.

Optional features for DP3T switches

COAXIAL DP3T
RELAYS

GENERAL

RADIALL DP3T / SPDT terminated are designed only with SMA connectors.

For all other connectors (N, BNC etc ..), the same function as SPDT Terminated can be easily performed with a standard DPDT and an external load.



POS 1 : J1 to J2 / J3 to load

Examples of dedicated applications



This SPDT Terminated is composed of a DP3T with SMA connectors and 2 RADIALL cable loads used as medium power terminations. The Key advantage of this solution is the ability to mount the switch with external terminations at power level desired.



This is an example of an SPDT terminated switch that was designed with 2 separate coils for a specific test network application.

To download technical data sheets, visit www.radiall.com & enter the part number in the Search box. For more detailed technical information please consult Radiall customer support.

Компания «Life Electronics» занимается поставками электронных компонентов импортного и отечественного производства от производителей и со складов крупных дистрибьюторов Европы, Америки и Азии.

С конца 2013 года компания активно расширяет линейку поставок компонентов по направлению коаксиальный кабель, кварцевые генераторы и конденсаторы (керамические, пленочные, электролитические), за счёт заключения дистрибьюторских договоров

Мы предлагаем:

- Конкурентоспособные цены и скидки постоянным клиентам.
- Специальные условия для постоянных клиентов.
- Подбор аналогов.
- Поставку компонентов в любых объемах, удовлетворяющих вашим потребностям.
- Приемлемые сроки поставки, возможна ускоренная поставка.
- Доставку товара в любую точку России и стран СНГ.
- Комплексную поставку.
- Работу по проектам и поставку образцов.
- Формирование склада под заказчика.
- Сертификаты соответствия на поставляемую продукцию (по желанию клиента).
- Тестирование поставляемой продукции.
- Поставку компонентов, требующих военную и космическую приемку.
- Входной контроль качества.
- Наличие сертификата ISO.

В составе нашей компании организован Конструкторский отдел, призванный помогать разработчикам, и инженерам.

Конструкторский отдел помогает осуществить:

- Регистрацию проекта у производителя компонентов.
- Техническую поддержку проекта.
- Защиту от снятия компонента с производства.
- Оценку стоимости проекта по компонентам.
- Изготовление тестовой платы монтаж и пусконаладочные работы.



Тел: +7 (812) 336 43 04 (многоканальный)

Email: org@lifeelectronics.ru