

Choose one component from each of the colored sections to assemble a complete switch.
For other options or further information please contact EAO Switch directly.

Product Profile

The Series 84 consists of indicators, momentary pushbuttons and low depth monoblock Emergency-stop switches. The indicators and pushbuttons are a modular system of lens, actuator and switching element with connections using plug-in terminals.

Within the many different colors, the lenses are available either in plastic or anodized aluminum.

Technical drawings see pages 78-79

- IP67 Protection (Switches and Indicators)
- IP65 Protection (Emergency-stop switches)
- Flush Mounting into 22.5mm cut out
- Illumination using Single or Multi-LED's in red, orange, yellow, green, blue or white
- Switching elements with solder or plug-in terminals or ribbon cable with 300mm length
- Switch Rating for indicator and pushbutton: 10mA - 100mA, 50mVAC/VDC - 42VAC/VDC
- Switch Rating for Emergency-stop switch: 3A/120VAC, 1.5A/240VAC
- LED Voltage for Emergency-stop switch: 5-30VDC
- All standard plastic lenses with the exception of black are transparent with translucent white diffuser
- Compact Emergency-stop meets EN 60947-5-1, EN 60947-5-5 and EN 418

Indicator



Indicator body for flush mount, black plastic, IP67 front protection, 22.5mm mounting

Part No.
84-0100.0

For complete switch also order **A**

Illuminated pushbutton



Pushbutton actuator for flush mount, black plastic, IP67 front protection, 22.5mm mounting

Part No.	Action	Size
84-1101.0	Momentary	25mm Ø

For complete switch also order **A**

Illuminated Emergency-stop switch



Emergency-stop red LED illuminated, plug-in terminals, twist release, 32mm diameter for 22.5mm mounting, foolproof to EN 60947-5-5, EN418

Part No.	Contact type
84-5021.2B20	1NC
84-5041.2B20	2NC
84-5031.2B20	1NC/1NO

See Series 04 for available legend plates



Emergency-stop red LED illuminated, ribbon cable, twist release, 32mm diameter for 22.5mm mounting, foolproof to EN 60947-5-5, EN418

Part No.	Contact type
84-5021.2B40	1NC
84-5041.2B40	2NC
84-5031.2B40	1NC/1NO

See Series 04 for available legend plates

Choose one component from each of the colored sections to assemble a complete switch.
For other options or further information please contact EAO Switch directly.

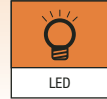
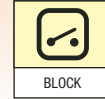

Emergency-stop switch **Indicator element**



Emergency-stop non illuminated, plug-in terminals, twist release, 32mm diameter for 22.5mm mounting, foolproof to EN 60947-5-5, EN 418



Emergency-stop non illuminated, ribbon cable, twist release, 32mm diameter for 22.5mm mounting, foolproof to EN 60947-5-5, EN 418



Indicator element, 24VDC LED, plug-in terminals, IP67

Part No.	Contact type	Part No.	Contact Type	Color	Part No.	Comment
84-5020.0020	1NC	84-5020.0040	1NC	● Red	84-8002.2620	Multi-chip LED
84-5040.0020	2NC	84-5040.0040	2NC	● Yellow	84-8002.4620	Multi-chip LED
84-5030.0020	1NC/1NO	84-5030.0040	1NC/1NO	● Green	84-8002.5620	Multi-chip LED
				● Blue	84-8001.6620	Single-chip LED
				○ White	84-8001.9620	Single-chip LED
See Series 04 for available legend plates		See Series 04 for available legend plates				

For complete switch also order **A**

Switch element **A Accessories**



Switching element, 24VDC LED, plug-in terminals, 1NO, IP67



Lens with white diffuser, plastic for flush mount, round indicator and pushbutton bodies

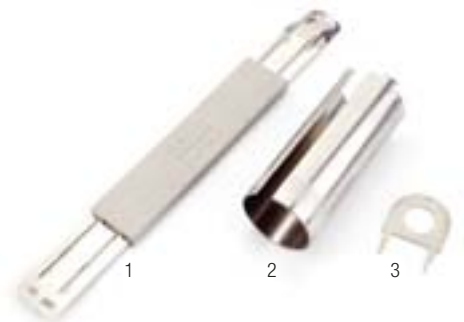

Lens remover for flush mount, mounting tool and switch element remover

Color	Part No.	Comment	Color	Part No.	Comment	Image	Part No.	Product description
● Red	84-8512.2620	Multi-chip LED	● Red	84-7111.200		1	61-9730.0	Lens remover for flush mount
● Yellow	84-8512.4620	Multi-chip LED	● Yellow	84-7111.400		2	84-997	Mounting tool
● Green	84-8512.5620	Multi-chip LED	● Green	84-7111.500		3	84-998	Switch element remover
● Blue	84-8511.6620	Single-chip LED	● Blue	84-7111.600				
○ White	84-8511.9620	Single-chip LED	○ Clear	84-7111.700				
	84-8510.0020	No LED - switching element only	● Black	84-7121.000	Not for illumination			

For complete switch also order **A**

84 Complete Indicator, Complete Pushbutton

Flush, plug-in terminals

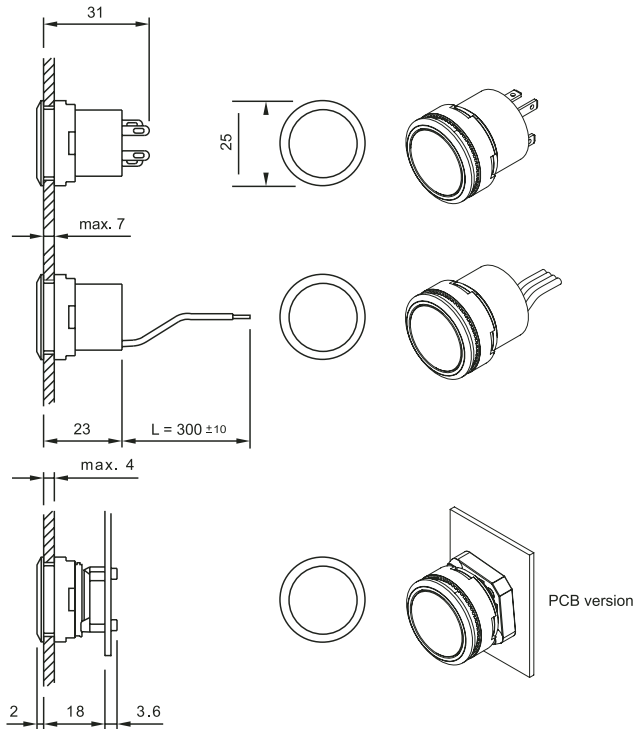

84 E-Stop

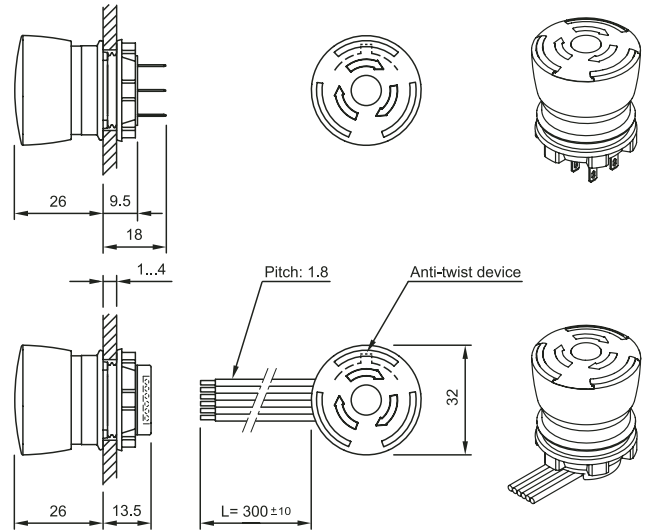

84 Cut-outs

Indicator Housing, Pushbutton Actuator

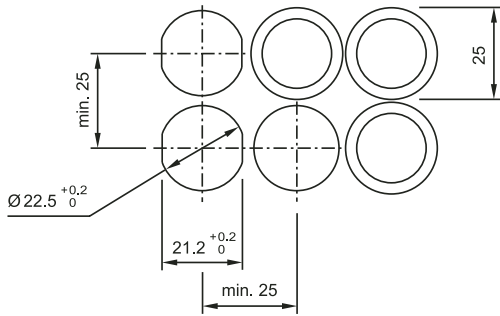

84 Cut-outs

E-Stop, EN 418 Illuminated Ribbon Cable, E-Stop EN 418 Non-Illuminated Ribbon Cable

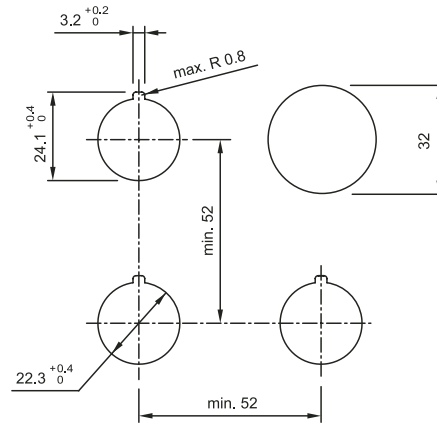

84 E-Stop

Ribbon cable wiring

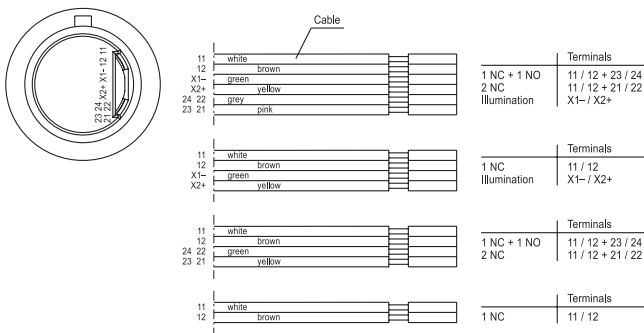

84 E-Stop

Solder wiring

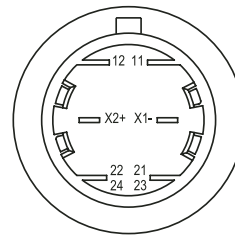

Компания «Life Electronics» занимается поставками электронных компонентов импортного и отечественного производства от производителей и со складов крупных дистрибьюторов Европы, Америки и Азии.

С конца 2013 года компания активно расширяет линейку поставок компонентов по направлению коаксиальный кабель, кварцевые генераторы и конденсаторы (керамические, пленочные, электролитические), за счёт заключения дистрибьюторских договоров

Мы предлагаем:

- Конкуренспособные цены и скидки постоянным клиентам.
- Специальные условия для постоянных клиентов.
- Подбор аналогов.
- Поставку компонентов в любых объемах, удовлетворяющих вашим потребностям.
- Приемлемые сроки поставки, возможна ускоренная поставка.
- Доставку товара в любую точку России и стран СНГ.
- Комплексную поставку.
- Работу по проектам и поставку образцов.
- Формирование склада под заказчика.
- Сертификаты соответствия на поставляемую продукцию (по желанию клиента).
- Тестирование поставляемой продукции.
- Поставку компонентов, требующих военную и космическую приемку.
- Входной контроль качества.
- Наличие сертификата ISO.

В составе нашей компании организован Конструкторский отдел, призванный помогать разработчикам, и инженерам.

Конструкторский отдел помогает осуществить:

- Регистрацию проекта у производителя компонентов.
- Техническую поддержку проекта.
- Защиту от снятия компонента с производства.
- Оценку стоимости проекта по компонентам.
- Изготовление тестовой платы монтаж и пусконаладочные работы.



Тел: +7 (812) 336 43 04 (многоканальный)

Email: org@lifeelectronics.ru