

FEATURES

- 8-Bit Resolution
- No Missed Codes over Full Temperature Range
- Fast Conversion Time: 15μs
- Interfaces to μP like RAM, ROM or Slow - Memory
- Low Power Dissipation: 30mW
- Ratiometric Capability
- Single +5V Supply
- Low Cost
- Internal Comparator and Clock Oscillator

FUNCTIONAL BLOCK DIAGRAM

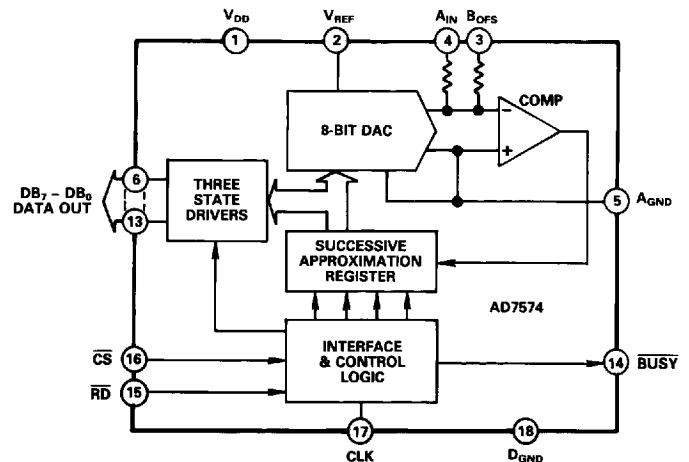

GENERAL DESCRIPTION

AD7574 is a low-cost, 8-bit μP compatible ADC which uses the successive-approximations technique to provide a conversion time of 15μs.

Designed to be operated as a memory mapped input device, the AD7574 can be interfaced like static RAM, ROM, or slow memory. Its \overline{CS} (decoded device address) and \overline{RD} ($\overline{READ}/\overline{WRITE}$ control) inputs are available in all μP memory systems. These two inputs control all ADC operations such as starting conversion or reading data. The ADC output data bits use three-state logic, allowing direct connection to the μP data bus or system input port.

Internal clock, +5V operation, on-board comparator and interface logic, as well as low power dissipation (30mW) and fast conversion time make the AD7574 ideal for most ADC/μP interface applications. Small size (18-pin DIP) and monolithic reliability will find wide use in avionics, instrumentation, and process automation applications.

PIN CONFIGURATION

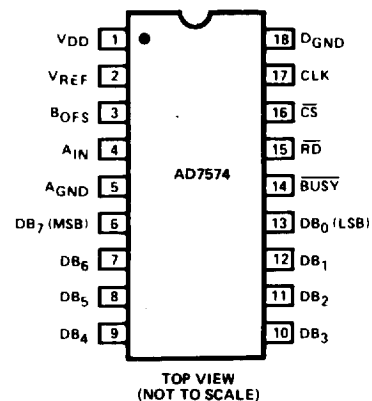

ORDERING GUIDE

Model	Temperature Range	Differential Nonlinearity (LSB)	Package Option*
AD7574JN	0°C to +70°C	±7/8 max	N-24
AD7574KN	0°C to +70°C	±3/4 max	N-24
AD7574AQ	-25°C to +85°C	±7/8 max	Q-24
AD7574BQ	-25°C to +85°C	±3/4 max	Q-24
AD7574SQ	-55°C to +125°C	±7/8 max	Q-24
AD7574TQ	-55°C to +125°C	±3/4 max	Q-24

*N = Plastic DIP; Q = Cerdip.

REV. A

Information furnished by Analog Devices is believed to be accurate and reliable. However, no responsibility is assumed by Analog Devices for its use, nor for any infringements of patents or other rights of third parties which may result from its use. No license is granted by implication or otherwise under any patent or patent rights of Analog Devices.

AD7574—SPECIFICATIONS

DC SPECIFICATIONS ($V_{DD} = +5V$, $V_{REF} = -10V$, Unipolar Configuration, $R_{CLK} = 180k\Omega$, $C_{CLK} = 100pF$, unless otherwise noted)

Parameter	Limits		Units	Conditions/Comments
	$T_A = +25^\circ C$	T_{min}, T_{max}^1		
ACCURACY				
Resolution	8	8	Bits	
Relative Accuracy Error				Relative Accuracy and Differential Nonlinearity are measured dynamically using the external clock circuit of Figure 7b. Clock frequency is 500kHz (conversion time 15 μ s).
J, A, S Versions	$\pm 3/4$	$\pm 3/4$	LSB max	
K, B, T Versions	$\pm 1/2$	$\pm 1/2$	LSB max	
Differential Nonlinearity				Full Scale Error is measured after calibrating out offset error. See Figure 8a and associated calibration procedure for offset. Max Full Scale change from $+25^\circ C$ to T_{min} or T_{max} is $\pm 2LSB$.
J, A, S Versions	$\pm 7/8$	$\pm 7/8$	LSB max	
K, B, T Versions	$\pm 3/4$	$\pm 3/4$	LSB max	
Full Scale Error (Gain Error)				Maximum Offset change from $+25^\circ C$ to T_{min} or T_{max} is $\pm 20mV$.
J, A, S Versions	± 5	± 6.5	LSB max	
K, B, T Versions	± 3	± 4.5	LSB max	
Offset Error ²				
J, A, S Versions	± 60	± 80	mV max	
K, B, T Versions	± 30	± 50	mV max	
Mismatch Between B_{OFS} (Pin 3) and A_{IN} (Pin 4) Resistances ³	± 1.5	± 1.5	% max	
ANALOG INPUTS				
Input Resistance				
At V_{REF} (Pin 2)	5/10/15	5/10/15	k Ω min/typ/max	
At B_{OFS} (Pin 3)	10/20/30	10/20/30	k Ω min/typ/max	
At A_{IN} (Pin 4)	10/20/30	10/20/30	k Ω min/typ/max	
V_{REF} (for Specified Performance)	-10	-10	V	$\pm 5\%$ for specified transfer accuracy.
V_{REF} Range ⁴	-5 to -15	-5 to -15	V	Degraded transfer accuracy.
Nominal Analog Input Range				
Unipolar Mode	0 to $+ V_{REF} $		V	
Bipolar Mode	$- V_{REF} $ to $+ V_{REF} $		V	
LOGIC INPUTS				
RD (Pin 15), CS (Pin 16)				
V_{INH} Logic HIGH Input Voltage	+3.0	+3.0	V min	$V_{IN} = 0V, V_{DD}$
V_{INL} Logic LOW Input Voltage	+0.8	+0.8	V max	
I_{IN} Input Current	1	10	μA max	
C_{IN} Input Capacitance ⁵	5	5	pF max	
CLK (Pin 17)				
V_{INH} Logic HIGH Input Voltage	+3.0	+3.0	V min	During Conversion: $V_{IN(CLK)} \geq V_{INH(CLK)}$ During Conversion $V_{IN(CLK)} \leq V_{INL(CLK)}$ (see circuit of Figure 7b if external clock operation is required).
V_{INL} Logic LOW Input Voltage	+0.4	+0.4	V max	
I_{INH} Logic HIGH Input Current	+2	+2	mA max	
I_{INL} Logic LOW Input Current	1	10	μA max	
LOGIC OUTPUTS				
BUSY (Pin 14), DB_7 to DB_0 (Pins 6-13)				
V_{OH} Output HIGH Voltage	+4.0	+4.0	V min	$I_{SOURCE} = 40\mu A$ $I_{SINK} = 1.6mA$ $V_{OUT} = 0V$ or V_{DD}
V_{OL} Output LOW Voltage	+0.4	+0.8	V max	
I_{LKG} DB_7 to DB_0 Floating Stage Leakage	1	10	μA max	
Floating State Output Capacitance (DB_7 to DB_0) ⁵	7	7	pF max	
Output Code	Unipolar Binary, Offset Binary			See Figures 8a, 9a, 10a, and 8b, 9b, 10b.
POWER REQUIREMENTS				
V_{DD}	+5	+5	V	$\pm 5\%$ for specified performance.
I_{DD} (STANDBY)	5	5	mA max	
I_{REF}	V_{REF} divided by 5k Ω		max	$A_{IN} = 0V$, ADC in RESET condition. Conversion complete, prior to RESET.

NOTES

¹Temperature ranges as follows: J, K, Versions, $0^\circ C$ to $+70^\circ C$; A, B, Versions, $-25^\circ C$ to $+85^\circ C$; S, T Versions; $-55^\circ C$ to $+125^\circ C$.

²Typical offset temperature coefficient is $\pm 150\mu V/^\circ C$.

³ R_{BOFS}/R_{AIN} mismatch causes transfer function rotation about positive Full Scale. The effect is an offset and a gain term when using the circuit of Figure 9a.

⁴Typical value, not guaranteed or subject to test.

⁵Guaranteed but not tested.

Specifications subject to change without notice.

CAUTION

ESD (electrostatic discharge) sensitive device. The digital control inputs are Zener protected; however, permanent damage may occur on unconnected devices subject to high energy electrostatic fields. Unused devices must be stored in conductive foam or shunts. The protective foam should be discharged to the destination socket before devices are removed.



AC SPECIFICATIONS ($V_{DD} = +5V$, $C_{CLK} = 100pF$, $R_{CLK} = 180k\Omega$ unless otherwise noted)

Symbol	Specification	Limit at $T_A = +25^\circ C$	Limit at $T_A = T_{min}$	Limit at $T_A = T_{max}$	Conditions
STATIC RAM INTERFACE MODE (See Figure 1 and Table I)					
t_{CS}	CS Pulse Width Requirement	100ns min	150ns min	150ns min	
t_{WSCS}	RD to CS Setup Time	0 min	0 min	0 min	
t_{CBPD}	CS to BUSY Propagation Delay	90ns typ	70ns typ	150ns typ	BUSY Load = 20pF
		120ns max	120ns max	180ns max	BUSY Load = 100pF
		120ns type	100ns typ	180ns typ	
		150ns max	150ns max	200ns max	
t_{BSR}	BUSY to RD Setup Time	0 min	0 min	0 min	
t_{BSCS}	BUSY to CS Setup Time	0 min	0 min	0 min	
t_{RAD}	Data Access Time	120ns typ	100ns typ	180ns typ	DB ₀ -DB ₇ Load = 100pF
		150ns max	150ns max	220ns max	
		240ns typ	220ns typ	300ns typ	DB ₀ -DB ₇ Load = 100pF
		300ns max	300ns max	400ns max	
t_{RHD}	Data Hold Time	80ns typ	40ns typ	120ns typ	
		50ns min	30ns min	80ns min	
		120ns max	80ns max	180ns max	
t_{RHCS}	CS to RD Hold Time	250ns max	200 ns max	500ns max	
t_{RESET}	Reset Time Requirement	3 μ s min	3 μ s min	3 μ s min	
$t_{CONVERT}$	Conversion Time Using Internal Clock Oscillator	See Typical Data of Figure 7a			
$t_{CONVERT}$	Conversion Time Using External Clock	15 μ s	15 μ s	15 μ s	$f_{CLK} = 500kHz$ Circuit of Figure 7b
ROM INTERFACE MODE (See Figure 2 and Table II)					
t_{RAD}	Data Access Time	Same as RAM Mode			
t_{RHD}	Data Hold Time	Same as RAM Mode			
t_{WBPD}	RD HIGH to BUSY Propagation Delay	400ns typ	350ns typ	1 μ s typ	BUSY Load = 20 pF
		1.5 μ s	1.0 μ s	2.0 μ s	
t_{BSR}	BUSY to RD LOW Setup Time	RD can go LOW prior to BUSY = HIGH, but must not return HIGH until = BUSY HIGH. See Table II.			
$t_{CONVERT}$	Conversion Time Using Internal Clock Oscillator	See Typical data of Figure 7a. Add 2 μ s to data shown in Figure 7a for ROM Mode			
SLOW - MEMORY INTERFACE MODE (See Figure 3 and Table III)					
t_{CBPD}	CS to BUSY Propagation Delay	Same as RAM Mode			
t_{RESET}	Reset Time Requirement	Same as RAM Mode			
t_{RAD}	Data Access Time	Same as RAM Mode			
t_{RHD}	Data Hold Time	Same as RAM Mode			
$t_{CONVERT}$	Conversion Time	Same as RAM Mode			

ABSOLUTE MAXIMUM RATINGS*

V_{DD} to A_{GND}	0V, +7.0V
V_{DD} to D_{GND}	0V, +7.0V
A_{GND} to D_{GND}	-0.3V, V_{DD}
Digital Input Voltage to D_{GND} (Pins 15 and 16)	-0.3V, +15.0V
Digital Output Voltage to D_{GND} (Pins 6-14)	-0.3V, V_{DD}
CLK Input Voltage (Pin 17) to D_{GND}	-0.3V, V_{DD}
V_{REF} (Pin 2)	$\pm 20V$
V_{BOFS} (Pin 3)	$\pm 20V$
V_{AIN} (Pin 4)	$\pm 20V$
Operating Temperature Range	
Commercial (J, K Versions)	0°C to +70°C

Industrial (A, B Versions)	-25°C to +85°C
Extended (S, T Versions)	-55°C to +150°C
Storage Temperature Range	-65°C to +150°C
Lead Temperature (soldering, 10 secs)	+300°C
Power Dissipation (Package)	
Plastic (Suffix N)	
to +70°C	670mW
Derate above +70°C by	8.3mW/°C
Cerdip (Suffix Q)	
to +75°C	450mW
Derate above +75°C by	6mW/°C

*Stresses above those listed under "Absolute Maximum Ratings" may cause permanent damage to the device. This is a stress rating only and functional operation at or above this specification is not implied. Exposure to above maximum rating conditions for extended periods may affect device reliability.

TERMINOLOGY

RESOLUTION: Resolution is a measure of the *nominal* analog change required for a 1-bit change in the A/D converter's digital output. While normally expressed in a number of bits, the analog resolution of an n-bit unipolar A/D converter is $(2^{-n}) V_{REF}$. Thus, the AD7574, an 8-bit A/D converter, can resolve analog voltages as small as $(1/256) (V_{REF})$ when operated in a unipolar mode. When operated in a bipolar mode, the resolution is $(1/128) (V_{REF})$. Resolution does not imply accuracy. Usable resolution is limited by the differential nonlinearity of the A/D converter.

RELATIVE ACCURACY: Relative accuracy is the deviation of the ADC's actual code transition points from a straight line

drawn between the devices' measured zero and measured full scale transition points. Relative accuracy, therefore, is a measure of code *position*.

DIFFERENTIAL NONLINEARITY: Differential nonlinearity in an ADC is a measure of the size of an analog voltage range associated with any digital output code. As such, differential nonlinearity specifies code width (usable resolution). An ADC with a specified differential nonlinearity of $\pm n$ bits will exhibit codes ranging in width from 1LSB - n LSB to 1LSB + n LSB. A specified differential nonlinearity of less than ± 1 LSB guarantees no-missing-codes operation.

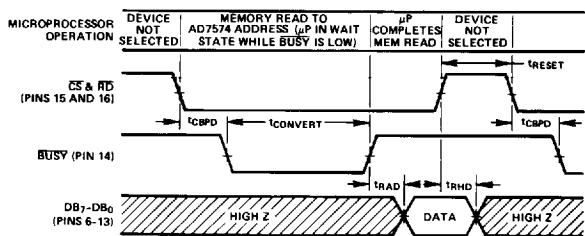

Figure 3. Slow Memory Mode Timing Diagram (CS and RD Tied Together)

Table III. Truth Table, Slow Memory Mode

AD7574 INPUTS	AD7574 OUTPUTS		AD7574 OPERATION
	CS & RD	BUSY	
H	H	HIGH Z	NOT SELECTED
L	H → L	HIGH Z	START CONVERSION
L	L	L	CONVERSION IN PROGRESS, μP IN WAIT STATE
L	L	HIGH Z → DATA	CONVERSION COMPLETE, μP READS DATA
L	H	DATA → HIGH Z	CONVERTER RESET AND DESELECTED
H	H	HIGH Z	NOT SELECTED

GENERAL CIRCUIT INFORMATION

BASIC CIRCUIT DESCRIPTION

The AD7574 uses the successive approximations technique to provide an 8-bit parallel digital output. The control logic was designed to provide easy interface to most microprocessors. Most applications require only passive clock components (R & C), a -10V reference, and +5V power.

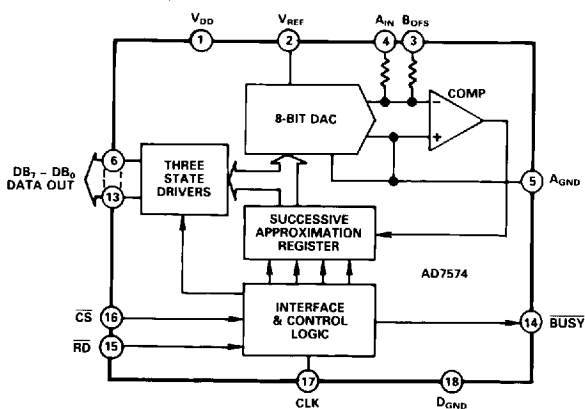

Figure 4. AD7574 Functional Diagram

Figure 4 shows the AD7574 functional diagram. Upon receipt of a start command either via the CS or RD pins, BUSY goes low indicating conversion is in progress. Successive bits, starting with the most significant bit (MSB) are applied to the input of a DAC. The comparator determines whether the addition of each successive bit causes the DAC output to be greater than or less than the analog input, AIN. If the sum of the DAC bits is less than AIN, the trial bit is left ON, and the next smaller bit is tried. If the sum is greater than AIN, the trial bit is turned OFF and the next smaller bit is tried.

Each successively smaller bit is tried and compared to AIN in this manner until the least significant bit (LSB) decision has been made. At this time BUSY goes HIGH (conversion is complete) indicating the successive approximation register contains a valid representation of the analog input. The RD control (see the previous page for details) can then be exercised to activate the three-state buffers, placing data on the DB0 - DB7 data output pins. RD returning HIGH causes the clock oscillator to run for 1 cycle, providing an internal ADC reset (i.e. the SAR is loaded with code 10000000).

DAC CIRCUIT DETAILS

The current weighting D/A converter is a precision multiplying DAC. Figure 5 shows the functional diagram of the DAC as used in the AD7574. It consists of a precision Silicon Chromium thin film R/2R ladder network and 8 N-channel MOS-FET switches operated in single-pole-double-throw.

The currents in each 2R shunt arm are binarily weighted, i.e. the current in the MSB arm is VREF divided by 2R, in the second arm is VREF divided by 4R, etc. Depending on the DAC logic input (A/D output) from the successive approximation register, the current in the individual shunt arms is steered either to AGND or to the comparator summing point.

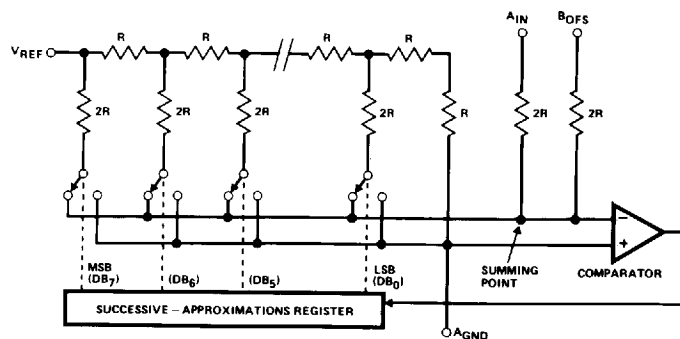

Figure 5. D/A Converter As Used In AD7574

AD7574

OPERATING THE AD7574

APPLICATION HINTS

1. TIMING & CONTROL

In the AD7574 when a conversion is finished the fresh data must be read before a new conversion can be started.

Failure to observe the timing restrictions of Figures 1, 2 or 3 may cause the AD7574 to change interface modes. For example, in the RAM mode, holding \overline{CS} LOW too long after \overline{RD} goes HIGH will cause a new convert start (i.e. the converter moved into the ROM mode).

2. LOGIC DEGLITCHING IN μP APPLICATIONS

Unspecified states on the address bus (due to different rise and fall times on the address bus) can cause glitches at the AD7574 \overline{CS} or \overline{RD} terminals. These glitches can cause unwanted convert starts, reads, or resets. The best way to avoid glitches is to gate the address decoding logic with RD or WR (8080) or VMA (6800) when in the ROM or RAM mode. When in the slow - memory mode, the ALE (8085) or SYNC (8080) signal should be used to latch the address.

3. INPUT LOADING AT V_{REF} , A_{IN} AND B_{OFS}

To prevent loading errors due to the finite input resistance at the V_{REF} , A_{IN} or B_{OFS} pins, low impedance driving sources must be used (i.e. op amp buffers or low output - Z reference).

4. RATIOMETRIC OPERATION

Ratiometric performance is inherent to A/D converters such as the AD7574 which use a multiplying DAC weighting network. However,

the user should recognize that comparator limitations such as offset voltage, input noise and gain will cause degradation of the transfer characteristics when operating with reference voltages less than -10V in magnitude.

5. OFFSET CORRECTION

Offset error in the transfer characteristic can be trimmed by offsetting the buffer amplifier which drives the AD7574 A_{IN} pin (pin 4). This can be done either by summing a cancellation current into the amplifier's summing junction, or by tapping a voltage divider which sits between V_{DD} and V_{REF} and applying the tap voltage to the amplifier's positive input (an example of a resistive tap offset adjust is shown in Figure 10a where R_8 , R_9 and R_{10} can be used to offset the ADC).

6. ANALOG AND DIGITAL GROUND

It is recommended that $AGND$ and $DGND$ be connected locally to prevent the possibility of injecting noise into the AD7574. In systems where the $AGND$ - $DGND$ intertie is not local, connect back - to - back diodes (IN914 or equivalent) between the AD7574 $AGND$ and $DGND$ pins.

7. INITIALIZATION AFTER POWER - UP

Execute a memory READ to the AD7574 address location, and subsequently ignore the data. The AD7574 is internally reset when reading out data, i.e. the data readout is destructive.

CLOCK OSCILLATOR

The AD7574 has an internal asynchronous clock oscillator which starts upon receipt of a convert start command, and ceases oscillating when conversion is complete.

The clock oscillator requires an external R and C as shown in Figure 6. Nominal conversion times versus R_{CLK} and C_{CLK} is shown in Figure 7a. The curves shown in Figure 7a are applicable when operating in the RAM or slow - memory interface modes. When operating in the ROM interface mode, add $2\mu s$ to the typical conversion time values shown.

The AD7574 is guaranteed to provide transfer accuracy to published specifications for conversion times down to $15\mu s$, as indicated by the unshaded region of Figure 7a. Conversion times faster than $15\mu s$ can cause transfer accuracy degradation.

OPERATION WITH EXTERNAL CLOCK

For applications requiring a conversion time close to or equal to $15\mu s$, an external clock is recommended. Using an external clock precludes the possibility of converting faster than $15\mu s$ (which can cause transfer accuracy degradation) due to temperature drift - as may be the case when using the internal clock oscillator.

Figure 7b shows how the external clock must be connected. The \overline{BUSY} output of the AD7574 is connected to the three-state enable input of a 74125 three - state buffer. R_1 is used as a pullup, and can be between $6k\Omega$ and $100k\Omega$. A 500kHz clock will provide a conversion time of $15\mu s$.

The external clock should be used only in the static - RAM or slow - memory interface mode, and *not* in the ROM mode.

Timing constraints for external clock operation are as follows:

STATIC RAM MODE

1. When initiating a conversion, \overline{CS} should go LOW on a positive clock edge to provide optimum settling time for the MSB.
2. A data READ can be initiated any time after $\overline{BUSY} = 1$.

SLOW-MEMORY MODE

1. When initiating a conversion, \overline{CS} and \overline{RD} should go LOW

on a positive clock edge to provide optimum settling time for the MSB.

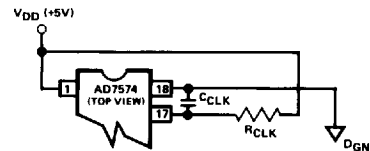

Figure 6. Connecting R_{CLK} and C_{CLK} To CLK Oscillator

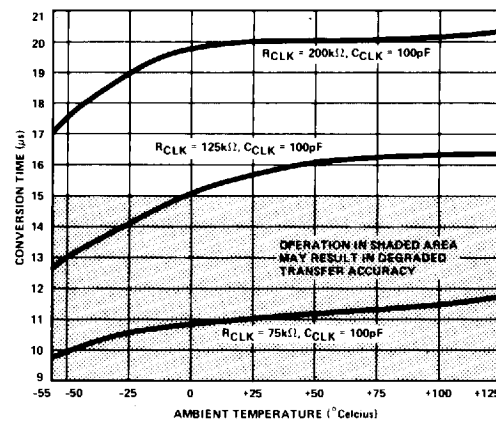

Figure 7a. Typical Conversion Time vs. Temperature For Different R_{CLK} and C_{CLK} (Applicable to RAM and Slow - Memory Modes. For ROM Mode add $2\mu s$ to values shown)

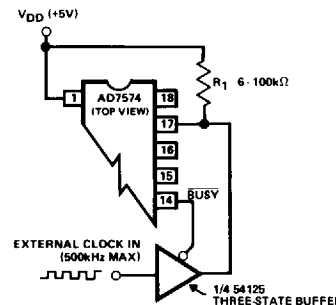

Figure 7b. External Clock Operation (Static RAM and Slow - Memory Mode)

UNIPOLAR BINARY OPERATION

Figures 8a and 8b show the analog circuit connections and typical transfer characteristic for unipolar operation. An AD584 is used as the -10V reference.

Calibration is as follows:

OFFSET

Offset must be trimmed out in the signal conditioning circuitry used to drive the signal input terminals shown in Figure 8a. An example of an offset trim is shown in Figure 10a, where R₈, R₉ and R₁₀ comprise a simple voltage tap which is applied to the amplifier's positive input.

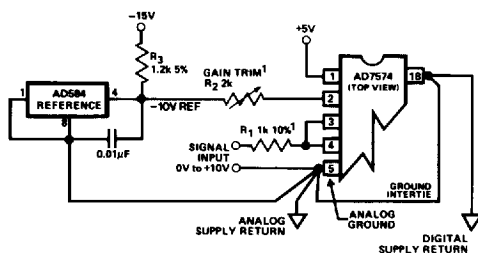

Note 1: R₁ and R₂ can be omitted if gain trim is not required

Figure 8a. AD7574 Unipolar (0V to +10V) Operation (Output Code is Straight Binary)

1. Apply -39.1mV (1 LSB) to the input of the buffer amplifier used to drive R₁ (i.e. +39.1mV at R₁).
2. While performing continuous conversions, adjust the offset potentiometer (described above) until DB₇-DB₁ are LOW and the LSB (DB₀) flickers.

GAIN (FULL SCALE)

Offset adjustment must be performed before gain adjustment.

1. Apply -9.961V to the input of the buffer amplifier used to drive R₁ (i.e. +9.961V at R₁).
2. While performing continuous conversions, adjust trim pot R₂ until DB₇-DB₁ are HIGH and the LSB (DB₀) flickers.

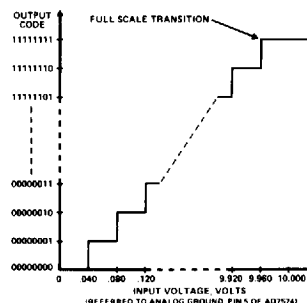

Note: Approximate bit weights are shown for illustration. Nominal bit weight for a -10V reference is ≈ 39.1mV

Figure 8b. Nominal Transfer Characteristic For Unipolar Circuit of Figure 8a

BIPOLAR (OFFSET BINARY) OPERATION

Figures 9a and 9b illustrate the analog circuitry and transfer characteristic for bipolar operation. Output coding is offset binary. As in unipolar operation, offset correction can be performed at the buffer amplifier used to drive the signal input terminals of Figure 9a (Resistors R₈, R₉ and R₁₀ in Figure 10a show how offset trim can be done at the buffer amplifier).

Calibration is as follows:

1. Adjust R₆ and R₇ for minimum resistance across the potentiometers.
2. Apply +10.000V to the buffer amplifier used to drive the signal input (i.e. -10.000V at R₆).
3. While performing continuous conversions, trim R₆ or R₇ (whichever required) until DB₇-DB₁ are LOW and the LSB (DB₀) flickers.

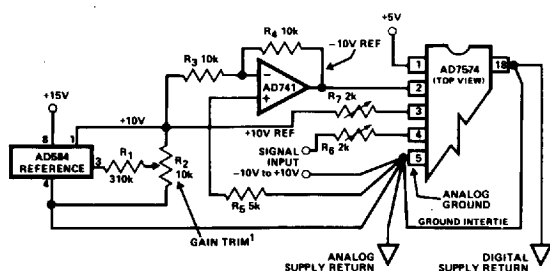

Note 1: R₁ and R₂ can be omitted if gain trim is not required

Figure 9a. AD7574 Bipolar (-10V to +10V) Operation (Output Code is Offset Binary)

4. Apply 0V to the buffer amplifier used to drive the signal input terminals.
5. Doing continuous conversions, trim the offset circuit of the buffer amplifier until the ADC output code flickers between 01111111 and 10000000.
6. Apply +10.000V to the input of the buffer amplifier (i.e. -10.000V as applied to R₆).
7. Doing continuous conversions, trim R₂ until DB₇-DB₁ are LOW and the LSB (DB₀) flickers.
8. Apply -9.922V to the input of the buffer amplifier (i.e. +9.922V at the input side of R₆).
9. If the ADC output code is not 11111110 ±1 bit, repeat the calibration procedure.

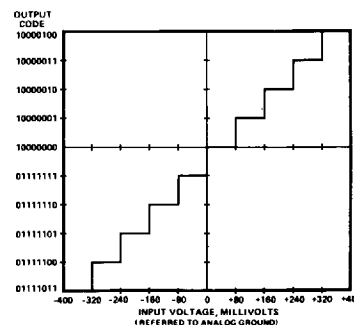

Note: Approximate bit weights are shown for illustration. Nominal bit weight for ± 10V full scale is ≈ 78.1mV

Figure 9b. Nominal Transfer Characteristic Around Major Carry for Bipolar Circuit of Figure 9a

AD7574

OPERATING THE AD7574

BIPOLAR (COMPLEMENTARY OFFSET BINARY) OPERATION

Figure 10a shows the analog connections for complementary offset binary operation. The typical transfer characteristic is shown in Figure 10b. In this bipolar mode, the ADC is fooled into believing it is operated in a unipolar mode - i.e. the +10V to -10V analog input is conditioned to a 0 to +10V signal range. R_2 is the gain adjust, while R_9 is the offset adjust.

Calibration is as follows (adjust offset before gain):

OFFSET

1. Apply 0V to the analog input shown in Figure 10a.

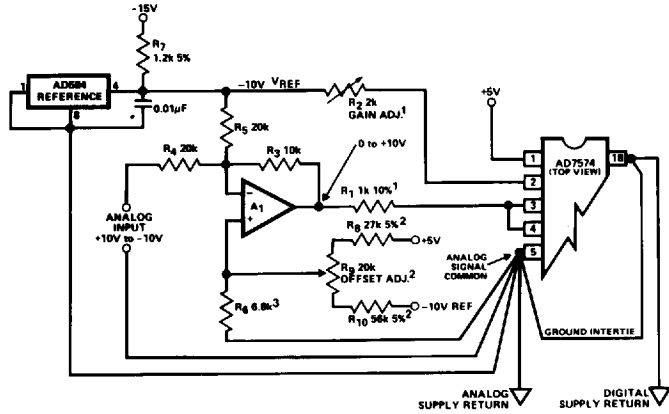

Notes:

1. R_1 and R_2 can be omitted if gain trim is not required
2. R_8 , R_9 and R_{10} can be omitted if offset trim is not required
3. $R_6 \parallel R_8 \parallel R_{10} = 5k\Omega$. If R_8 , R_9 and R_{10} not used, make $R_6 = 5k\Omega$

Figure 10a. AD7574 Bipolar Operation (-10V to +10V)
(Output Code is Complementary Offset Binary)

2. While performing continuous conversions, adjust R_9 until the converter output flickers between codes 01111111 and 10000000.

GAIN (FULL SCALE)

1. Apply -9.922V across the analog input terminals shown in Figure 10a.
2. While performing continuous conversions, adjust R_2 until $DB_7 - DB_1$ are HIGH and the LSB (DB_0) flickers between HIGH and LOW.

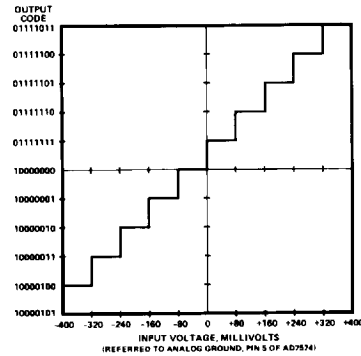

Note: Approximate bit weights are shown for illustration. Nominal bit weight for $\pm 10V$ full scale is $\approx 78.1mV$

Figure 10b. Nominal Transfer Characteristic Around Major Carry for Bipolar Circuit of Figure 10a

MECHANICAL INFORMATION

OUTLINE DIMENSIONS

Dimensions are shown in inches and (mm).

18 PIN PLASTIC DIP

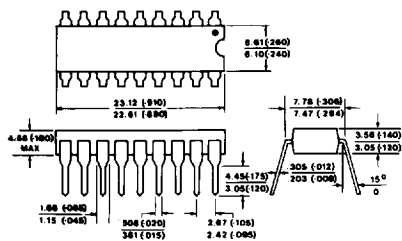

Notes:

1. Lead no. 1 identified by dot or notch.
2. Dimensions in mm (in.).
3. Leads are solder plated KOVAR or ALLOY 42.

18 PIN CERAMIC DIP

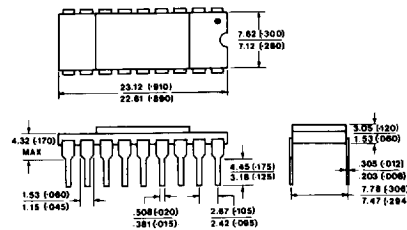

Notes:

1. Lead no. 1 identified by dot or notch.
2. Leads will be either gold or tin plated in accordance with MIL-M-38510 requirements.
3. Cavity lid is electrically isolated.

Компания «Life Electronics» занимается поставками электронных компонентов импортного и отечественного производства от производителей и со складов крупных дистрибьюторов Европы, Америки и Азии.

С конца 2013 года компания активно расширяет линейку поставок компонентов по направлению коаксиальный кабель, кварцевые генераторы и конденсаторы (керамические, пленочные, электролитические), за счёт заключения дистрибьюторских договоров

Мы предлагаем:

- Конкуренспособные цены и скидки постоянным клиентам.
- Специальные условия для постоянных клиентов.
- Подбор аналогов.
- Поставку компонентов в любых объемах, удовлетворяющих вашим потребностям.
- Приемлемые сроки поставки, возможна ускоренная поставка.
- Доставку товара в любую точку России и стран СНГ.
- Комплексную поставку.
- Работу по проектам и поставку образцов.
- Формирование склада под заказчика.
- Сертификаты соответствия на поставляемую продукцию (по желанию клиента).
- Тестирование поставляемой продукции.
- Поставку компонентов, требующих военную и космическую приемку.
- Входной контроль качества.
- Наличие сертификата ISO.

В составе нашей компании организован Конструкторский отдел, призванный помогать разработчикам, и инженерам.

Конструкторский отдел помогает осуществить:

- Регистрацию проекта у производителя компонентов.
- Техническую поддержку проекта.
- Защиту от снятия компонента с производства.
- Оценку стоимости проекта по компонентам.
- Изготовление тестовой платы монтаж и пусконаладочные работы.



Тел: +7 (812) 336 43 04 (многоканальный)

Email: org@lifeelectronics.ru