

HOLD DOWN TYPE

Amphenol FCI

© 2016 AFCI

mat'l. code		surface 58		tolerance		projection		product family		
-		ISO 1302		ISO 406 ISO		101		PCI_EXPRESS		
ltr	ecn no	dr	date	tolerances unless otherwise specified			title			
J	ELX-DG-14311	WL	2013/03/21	angles	.X±.3		MM	PCI_EXPRESS_CARD_EDGE_GEN3		
K	ELX-DG-16269	ST	2013/11/13		linear .XX±.20			ASSEMBLY(SMT)		
L	ELX-DG-21161-1	ST	2015/05/27		0°±2° XXX±.10			scale 1		
M	ELX-DG-24164	ZH	2016/06/01	dr	STONE_LI	2015/05/27	dwg no		sheet 1 of 6	size
N	ELX-DG-25671-1	ZH	2016/12/19	engr	STONE_LI	2015/05/27	10061913		A4	
P	ELX-DG-27937	ZH	2017/09/12	chr	/	/	type		CUSTOMER Drawing	
				appd	PM_ZHENG	2015/05/27				
sheet index	revision	P								
	sheet									

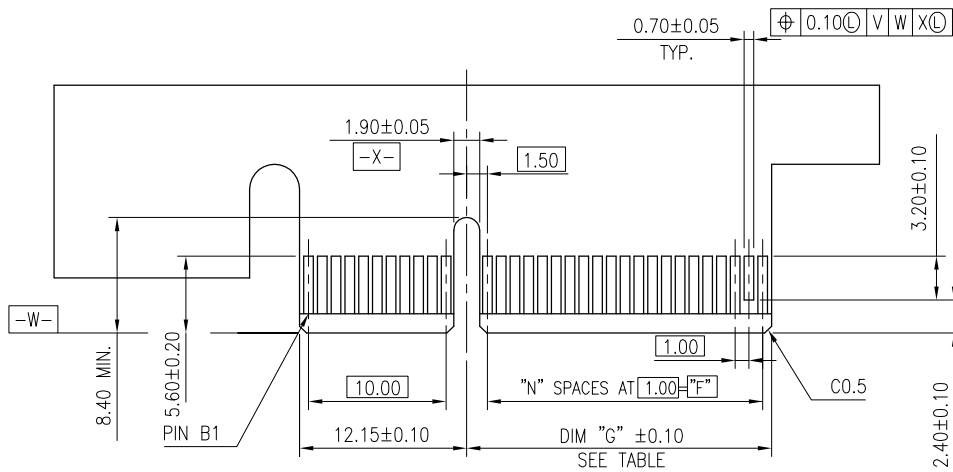

← I/O PANEL DIRECTION  
PRIMARY (COMPONENT) SIDE



I/O PANEL DIRECTION →  
SECONDARY (SOLDER) SIDE

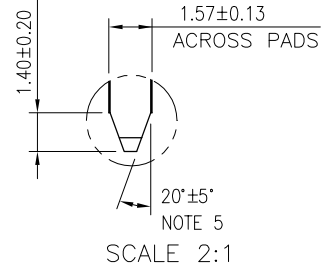

#	POS	REF.	N	DIM "G"	DIM "F"	"F"
36	6		8.15	6.00	B17	
64	20		22.15	20.00	B31	
98	37		39.15	37.00	B48	
164	70		72.15	70.00	B81	

ADD-IN CARD EDGE-FINGER DIMENSIONS

mat'l. code		surface 58/ISO 1302		tolerance ISO 406 ISO 101		projection		product family		
-		✓				MM		PCI_EXPRESS		
ltr	ecn no	dr	date	tolerances unless otherwise specified				title		
				angles	.X±.2		PCI_EXPRESS_CARD_EDGE_GEN3 ASSEMBLY(SMT)			
				linear	.XX±.13					
				0°±2°	XXX±.05					
				dr	STONE_LI	2015/05/27	scale 2		dwg no sheet 2 of 6 size	
				engr	STONE_LI	2015/05/27	Amphenol FCI		10061913 A4	
				chr	/	/			type	
				appd	PM_ZHENG	2015/05/27				
sheet index	revision sheet	P								

Amphenol FCI

© 2016 AFCI

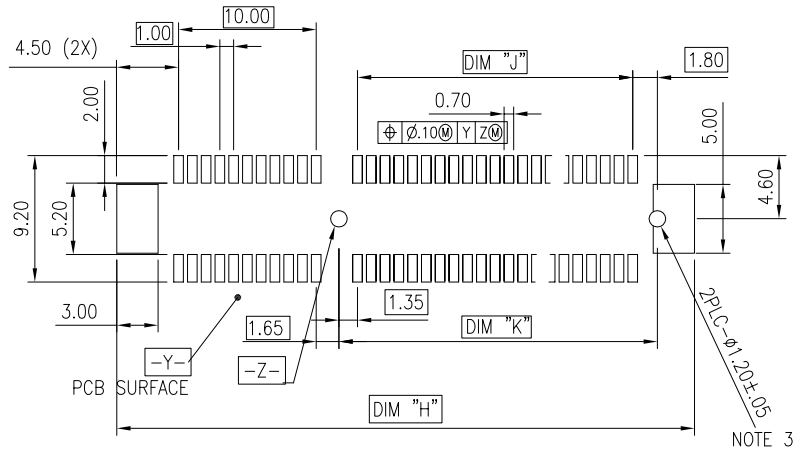

RECOMMENDED PCB LAYOUT, PAD TYPE

DIMENSIONS								
POSITION	A	B $\begin{smallmatrix} +0.15 \\ -0.05 \end{smallmatrix}$	C $\pm 0.20$	D $\pm 0.23$	E $\pm 0.20$	H $\pm 0.10$	J	K $\pm 0.10$
36	6.00	7.65	9.15	25.00	27.00	28.00	6.00	9.15
64	20.00	21.65	23.15	39.00	41.00	42.00	20.00	23.15
98	37.00	38.65	40.15	56.00	58.00	59.00	37.00	40.15
164	70.00	71.65	73.15	89.00	91.00	92.00	70.00	73.15

POSTION OF CAP

POSTION OF DUMMY CARD



POSTION OF CUSTOMIZED CAP(30X12)



Amphenol FCI

© 2016 AFCI

mat'l. code		surface 58/ISO 1302		tolerance ISO 406 ISO 101		product family PCI_EXPRESS	
ltr	ecn no	dr	date	tolerances unless otherwise specified		title	
				angles	.X±.2	PCI_EXPRESS_CARD_EDGE_GEN3 ASSEMBLY(SMT)	
				linear	.XX±.13	MM	
				0°±2°	XXX±.05	scale 2	
		dr	STONE_LI	2015/05/27	dwg no		sheet 3 of 6
		enr	STONE_LI	2015/05/27	10061913		size A4
		chr	/	/	type		CUSTOMER Drawing
		appd	PM_ZHENG	2015/05/27			
sheet index	revision	P					
	sheet						

NOTES:

1.MATERIAL:

HOUSING: NYLON, GLASS FILLED UL94V-0 RATE, SUITABLE FOR I.R SOLDERING.

TERMINAL: COPPER ALLOY

PLATING: 50u" NICKEL UNDERPLATE ALL OVER CONTACT AREA PLATING - SEE PRODUCT NUMBER CODE SOLDER TAIL: TIN 100u" OVER 50u" NICKEL

METAL PADS: COPPER ALLOY FINISH: 100u" TIN OVER 50u" NICKEL

2.PRODUCT SPECIFICATION: GS-12-390

③THE HORIZONTAL AXIS FOR THE PAD PATTERN IS ESTABLISHED BY A LINE THROUGH THE CENTER OF THE TWO Ø1.0 HOLES. THE VERTICAL AXIS IS 90° TO THE HORIZONTAL AXIS, THROUGH THE CENTER OF DATUM [Z-]

④NO TIE BAR PERMITTED FROM CARD EDGE TO LEADING EDGE OF PAD FOR PINS A1.

⑤CHAMFER EDGES MUST BE FREE OF CUTTING BURRS.

6.RoHS COMPATIBLE PRODUCT SPECIFICATIONS

a - PLATING:

- "LF" MEANS THE PRODUCT IS LEAD-FREE

b - MANUFACTURING PROCESS COMPATIBILITY

- THE HOUSING WILL WITHSTAND EXPOSURE TO 260°C±5°C PEAK TEMPERATURE FOR 5 SECONDS IN A CONVECTION, INFRA-RED OR VAPOR PHASE REFLOW OVEN.

7.A ΔSYMBOL WILL BE NEXT TO ANY DIMENSION, VIEW, OR NOTE WHICH HAS BEEN MODIFIED WITH CURRENT DRAWING REVISION.



POSITION OF MYLAR

PRODUCT NUMBER CODE

10061913-X X X X L F LEAD FREE

HOUSING COLOR OPTIONS

- 0-WHITE
1-BLACK

PACKAGING OPTIONS

- T-TRAY PACKAGING WITHOUT CAP
C-TRAY PACKAGING WITH CAP
N-TRAY PACKAGING WITH MYLAR
G-TRAY PACKAGING WITH DUMMY CARD
V-TRAY FOR VACUUM PACKAGING
R-TAPE & REEL PACKAGING WITHOUT CAP OR MYLAR (FOR 36P & 64P ONLY)
P-TAPE & REEL PACKAGING WITH CAP (FOR 36P & 64P& 98P ONLY)
Q-TAPE & REEL PACKAGING WITH CAP ( CUSTOMIZED FOR 98P ONLY)
M-TAPE & REEL PACKAGING WITH MYLAR (FOR 36P & 64P & 98P ONLY)
J-TAPE & REEL PACKAGING(24MM PITCH) WITH MYLAR (FOR 98P & 164P ONLY)
U-REEL FOR VACUUM PACKAGING
A-44MM WIDTH TAPE&REEL PACKING WITH MYLAR(FOR 36P ONLY)
Y-HARD TRAY (338x234 FOR 36P, 98P & 164P OPTION ONLY)
Z-HARD TRAY (338x234)WITH MYLAR (FOR 36P, 98P & 164P OPTION ONLY)
B-HARD TRAY (338x234)WITH CAP (FOR 36P, 98P & 164P OPTION ONLY)
H-CUSTOMIZED HARD TRAY (330x235x19.3)WITH 30mm CAP (FOR 98 & 164P ONLY)
D-SMALLER HARD TRAY WITH CHAMFER AT LEFT-BOTTOM SIDE (323x136x19) WITH 30mm CAP (FOR 164P ONLY) Δ

TERMINAL PLATING OPTIONS

- 0-50u" Ni UNDERPLATE
30u" Au CONTACT AREA
100u" TIN TAIL AREA ----- COMPATIBLE RoHS
1-50u" Ni UNDERPLATE
15u" Au CONTACT AREA
100u" TIN TAIL AREA ----- COMPATIBLE RoHS
2-50u" Ni UNDERPLATE
GOLD FLASH CONTACT AREA
100u" TIN TAIL AREA ----- COMPATIBLE RoHS
3-50u" Ni UNDERPLATE
30u" Au CONTACT AREA
GOLD FLASH TAIL AREA ----- COMPATIBLE RoHS

POS OPTIONS

- 0-36
1-64
2-98
3-164

Amphenol FCI

© 2016 AFCI

Table with columns for material code, surface, tolerance, projection, product family, title, and drawing information. Includes Amphenol FCI logo and part number 10061913.



TAPE AND REEL  
 PACKING  
 RECOMMENDED FOR  
 36PINS ONLY

DIMENSIONS					
POSITIONS	A	B	C	D REF.	E REF.
36 (10061913-xxxALF)	44.00	40.40	20.20	44.5	50.5
36	56.00	52.60	26.30	56.4	60.4
64	56.00	52.60	26.30	56.4	60.4
98	88.00	79.60	39.80	88.4	92.4

Amphenol FCI

© 2016 AFCI

mat'l. code		surface 58		tolerance		projection		product family			
-		ISO 1302		ISO 406 ISO		101		PCI_EXPRESS			
ltr	ecn no	dr	date	tolerances unless otherwise specified				title			
				angles		MM		PCI_EXPRESS_CARD_EDGE_GEN3 ASSEMBLY(SMT)			
				linear		scale 1		dwg no			
				0°±2°				sheet 5 of 6			
				dr	STONE_LI	2015/05/27	Amphenol FCI		size		
				engr	STONE_LI	2015/05/27			10061913		A4
				chr	/	/			type		CUSTOMER Drawing
				appd	PM_ZHENG	2015/05/27					
sheet index	revision sheet	P									

1 For PCI EXPRESS SMT TYPE 36P ONLY.

2. Material :

- 2.1 Reel :
  - 2.1.1 Plastic hub : High Impact Polystyrene
  - 2.1.2 Cover tape : PE
  - 2.1.3 Carrier tape : ABS
- 2.2 Waterproof bag : PE
- 2.3 Desiccative : Silica Gel
- 2.4 Carton : Corrugated paper
- 2.5 Baffle : E.P.E
- 2.6 Angle paperboard : Corrugated paper

3. Dimension :

- 3.1 Reel :
  - 3.1.1 Plastic hub :  $\phi 330 \times T50.5$  mm
  - 3.1.2 Cover tape : 5690(L) x 37.4(W) mm
  - 3.1.3 Carrier tape : 5640(L) x 44(W)mm
- 3.2 Waterproof bag : 600(H) x 465(W) x 0.06(T) mm
- 3.3 Desiccative : 25 gram / Package
- 3.4 Carton : 380(L) x 380(W) x 300(H) mm
- 3.5 Baffle (1): 370(L) x 370(W) x 15(H) mm
- 3.6 Baffle (2): 355(L) x 252(W) x 15(H) mm
- 3.7 Angle paperboard : 252(H)

4. Quantity :

- 4.1 250 Pcs / Reel
- 4.2 1250 Pcs / Carton

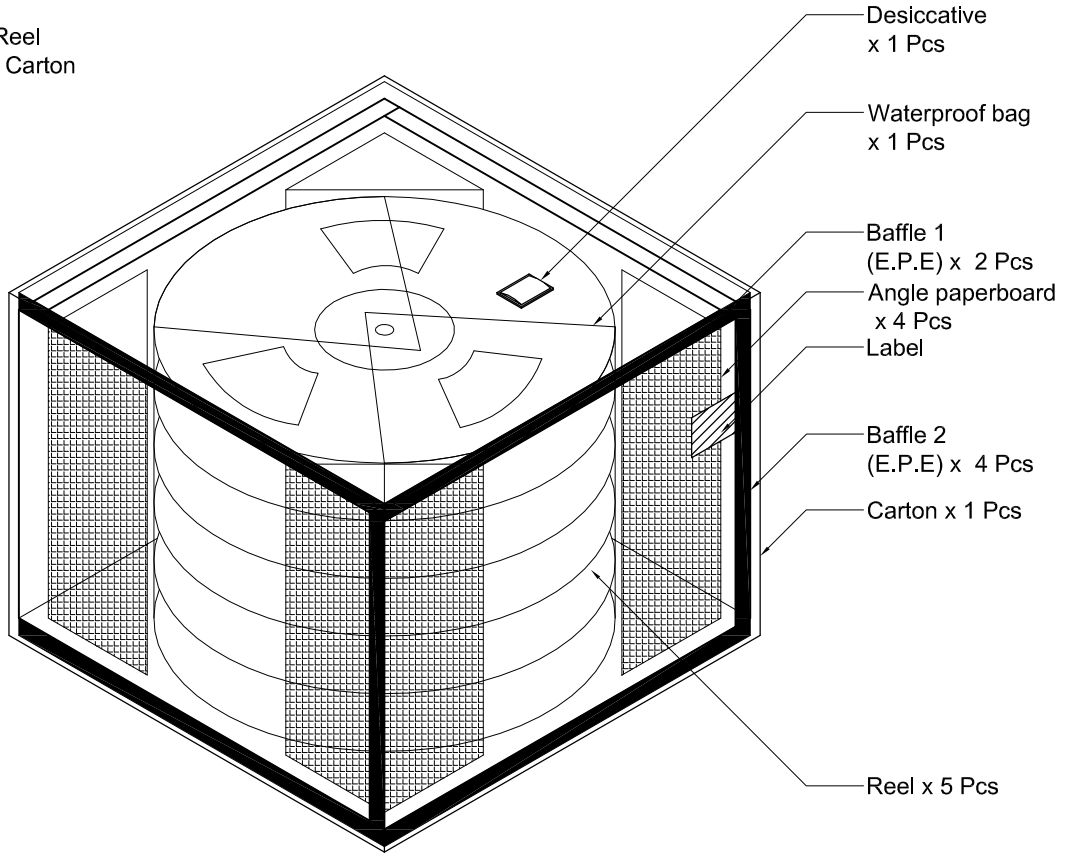

Amphenol FCI

© 2016 AFCI

©

mat'l. code		surface 58/ISO 1302 ✓		tolerance ISO 406 ISO 101		projection		product family PCI_EXPRESS			
ltr	ecn no	dr	date	tolerances unless otherwise specified				title			
				angles	.X±.3		MM	PCI_EXPRESS_CARD_EDGE_GEN3 ASSEMBLY(SMT)			
				linear	.XX±.20						
				0°±2°	XXX±.10						
		dr	STONE_LI	2015/05/27					sheet 6 of 6		size
		engr	STONE_LI	2015/05/27					10061913		A4
		chr	/	/							
		appd	PM_ZHENG	2015/05/27							
sheet index	revision	P						type CUSTOMER Drawing			

Компания «Life Electronics» занимается поставками электронных компонентов импортного и отечественного производства от производителей и со складов крупных дистрибьюторов Европы, Америки и Азии.

С конца 2013 года компания активно расширяет линейку поставок компонентов по направлению коаксиальный кабель, кварцевые генераторы и конденсаторы (керамические, пленочные, электролитические), за счёт заключения дистрибьюторских договоров

Мы предлагаем:

- Конкурентоспособные цены и скидки постоянным клиентам.
- Специальные условия для постоянных клиентов.
- Подбор аналогов.
- Поставку компонентов в любых объемах, удовлетворяющих вашим потребностям.
- Приемлемые сроки поставки, возможна ускоренная поставка.
- Доставку товара в любую точку России и стран СНГ.
- Комплексную поставку.
- Работу по проектам и поставку образцов.
- Формирование склада под заказчика.
- Сертификаты соответствия на поставляемую продукцию (по желанию клиента).
- Тестирование поставляемой продукции.
- Поставку компонентов, требующих военную и космическую приемку.
- Входной контроль качества.
- Наличие сертификата ISO.

В составе нашей компании организован Конструкторский отдел, призванный помогать разработчикам, и инженерам.

Конструкторский отдел помогает осуществить:

- Регистрацию проекта у производителя компонентов.
- Техническую поддержку проекта.
- Защиту от снятия компонента с производства.
- Оценку стоимости проекта по компонентам.
- Изготовление тестовой платы монтаж и пусконаладочные работы.



Тел: +7 (812) 336 43 04 (многоканальный)

Email: [org@lifeelectronics.ru](mailto:org@lifeelectronics.ru)