

HOLD DOWN TYPE

Amphenol FCI

© 2016 AFCI

mat'l. code		surface 58		tolerance		projection		product family		
-		ISO 1302		ISO 406 ISO		101		PCI_EXPRESS		
ltr	ecn no	dr	date	tolerances unless otherwise specified			title			
J	ELX-DG-14311	WL	2013/03/21	angles	.X±.3		MM	PCI_EXPRESS_CARD_EDGE_GEN3		
K	ELX-DG-16269	ST	2013/11/13		linear	.XX±.20		ASSEMBLY(SMT)		
L	ELX-DG-21161-1	ST	2015/05/27	0°±2°	XXX±.10		scale 1			
M	ELX-DG-24164	ZH	2016/06/01	dr	STONE_LI	2015/05/27	Amphenol FCI	dwg no	sheet 1 of 6	size
N	ELX-DG-25671-1	ZH	2016/12/19	engr	STONE_LI	2015/05/27		10061913		A4
P	ELX-DG-27937	ZH	2017/09/12	chr	/	/				
				appd	PM_ZHENG	2015/05/27		type	CUSTOMER Drawing	
sheet index	revision	P								
	sheet									



I/O PANEL DIRECTION
PRIMARY (COMPONENT) SIDE



I/O PANEL DIRECTION
SECONDARY (SOLDER) SIDE

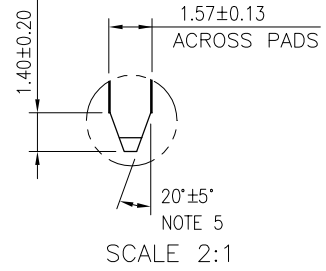

#	POS	REF.	N	DIM "G"	DIM "F"	"F"
36	6		8.15	6.00	B17	
64	20		22.15	20.00	B31	
98	37		39.15	37.00	B48	
164	70		72.15	70.00	B81	

PIN "F" SEE TABLE

ADD-IN CARD EDGE-FINGER DIMENSIONS

mat'l. code		surface 58/ISO 1302		tolerance ISO 406 ISO 101		projection		product family		
-		✓				101		PCI_EXPRESS		
ltr	ecn no	dr	date	tolerances unless otherwise specified		MM		title		
				angles	.X±.2	← →		PCI_EXPRESS_CARD_EDGE_GEN3 ASSEMBLY(SMT)		
				linear	.XX±.13					
				0°±2°	XXX±.05	scale 2				
		dr	STONE_LI	2015/05/27			dwg no		sheet 2 of 6	size
		engr	STONE_LI	2015/05/27			10061913		A4	
		chr	/	/						
		appd	PM_ZHENG	2015/05/27						
sheet index	revision	P						type		CUSTOMER Drawing
	sheet									



RECOMMENDED PCB LAYOUT, PAD TYPE

DIMENSIONS								
POSITION	A	B $\begin{smallmatrix} +0.15 \\ -0.05 \end{smallmatrix}$	C ± 0.20	D ± 0.23	E ± 0.20	H ± 0.10	J	K ± 0.10
36	6.00	7.65	9.15	25.00	27.00	28.00	6.00	9.15
64	20.00	21.65	23.15	39.00	41.00	42.00	20.00	23.15
98	37.00	38.65	40.15	56.00	58.00	59.00	37.00	40.15
164	70.00	71.65	73.15	89.00	91.00	92.00	70.00	73.15

POSTION OF CAP

POSTION OF DUMMY CARD



POSTION OF CUSTOMIZED CAP(30X12)



Amphenol FCI

© 2016 AFCI

mat'l. code		surface 58/ISO 1302		tolerance ISO 406 ISO 101		projection		product family		
-		✓				MM		PCI_EXPRESS		
ltr	ecn no	dr	date	tolerances unless otherwise specified				title		
				angles		linear		PCI_EXPRESS_CARD_EDGE_GEN3 ASSEMBLY(SMT)		
				.X±.2		scale 2		dwg no		
				.XX±.13				sheet 3 of 6		
				0°±2°				size		
				dr	STONE_LI	2015/05/27	Amphenol FCI		10061913	
				enr	STONE_LI	2015/05/27			A4	
				chr	/	/			type	
				appd	PM_ZHENG	2015/05/27	CUSTOMER Drawing			
sheet index	revision	P								
	sheet									

NOTES:

1.MATERIAL:

HOUSING: NYLON, GLASS FILLED UL94V-0 RATE, SUITABLE FOR I.R SOLDERING.

TERMINAL: COPPER ALLOY

PLATING: 50u" NICKEL UNDERPLATE ALL OVER
CONTACT AREA PLATING - SEE PRODUCT NUMBER CODE
SOLDER TAIL: TIN 100u" OVER 50u" NICKEL

METAL PADS: COPPER ALLOY
FINISH: 100u" TIN OVER 50u" NICKEL

2.PRODUCT SPECIFICATION: GS-12-390

③THE HORIZONTAL AXIS FOR THE PAD PATTERN IS ESTABLISHED BY
A LINE THROUGH THE CENTER OF THE TWO Ø1.0 HOLES.
THE VERTICAL AXIS IS 90° TO THE HORIZONTAL AXIS, THROUGH THE CENTER
OF DATUM [Z-]

④NO TIE BAR PERMITTED FROM CARD EDGE TO LEADING EDGE OF PAD FOR
PINS A1.

⑤CHAMFER EDGES MUST BE FREE OF CUTTING BURRS.

6.RoHS COMPATIBLE PRODUCT SPECIFICATIONS

a - PLATING:

- "LF" MEANS THE PRODUCT IS LEAD-FREE

b - MANUFACTURING PROCESS COMPATIBILITY

- THE HOUSING WILL WITHSTAND EXPOSURE TO 260°C±5°C PEAK TEMPERATURE FOR
5 SECONDS IN A CONVECTION, INFRA-RED OR VAPOR PHASE REFLOW OVEN.

7.A Δ SYMBOL WILL BE NEXT TO ANY DIMENSION, VIEW, OR NOTE WHICH HAS BEEN MODIFIED
WITH CURRENT DRAWING REVISION.



POSITION OF MYLAR

PRODUCT NUMBER CODE

10061913-X X X X L F LEAD FREE

HOUSING COLOR OPTIONS

- 0-WHITE
- 1-BLACK

PACKAGING OPTIONS

- T-TRAY PACKAGING WITHOUT CAP
- C-TRAY PACKAGING WITH CAP
- N-TRAY PACKAGING WITH MYLAR
- G-TRAY PACKAGING WITH DUMMY CARD
- V-TRAY FOR VACUUM PACKAGING
- R-TAPE & REEL PACKAGING WITHOUT CAP OR MYLAR (FOR 36P & 64P ONLY)
- P-TAPE & REEL PACKAGING WITH CAP (FOR 36P & 64P & 98P ONLY)
- Q-TAPE & REEL PACKAGING WITH CAP (CUSTOMIZED FOR 98P ONLY)
- M-TAPE & REEL PACKAGING WITH MYLAR (FOR 36P & 64P & 98P ONLY)
- J-TAPE & REEL PACKAGING(24MM PITCH) WITH MYLAR (FOR 98P & 164P ONLY)
- U-REEL FOR VACUUM PACKAGING
- A-44MM WIDTH TAPE&REEL PACKING WITH MYLAR(FOR 36P ONLY)
- Y-HARD TRAY (338x234 FOR 36P, 98P & 164P OPTION ONLY)
- Z-HARD TRAY (338x234)WITH MYLAR (FOR 36P, 98P & 164P OPTION ONLY)
- B-HARD TRAY (338x234)WITH CAP (FOR 36P, 98P & 164P OPTION ONLY)
- H-CUSTOMIZED HARD TRAY (330x235x19.3)WITH 30mm CAP (FOR 98 & 164P ONLY)
- D-SMALLER HARD TRAY WITH CHAMFER AT LEFT-BOTTOM SIDE (323x136x19) WITH 30mm CAP (FOR 164P ONLY) Δ

TERMINAL PLATING OPTIONS

- 0-50u" Ni UNDERPLATE
30u" Au CONTACT AREA
100u" TIN TAIL AREA ----- COMPATIBLE RoHS
- 1-50u" Ni UNDERPLATE
15u" Au CONTACT AREA
100u" TIN TAIL AREA ----- COMPATIBLE RoHS
- 2-50u" Ni UNDERPLATE
GOLD FLASH CONTACT AREA
100u" TIN TAIL AREA ----- COMPATIBLE RoHS
- 3-50u" Ni UNDERPLATE
30u" Au CONTACT AREA
GOLD FLASH TAIL AREA ----- COMPATIBLE RoHS

POS OPTIONS

- 0-36
- 1-64
- 2-98
- 3-164

Amphenol FCI

© 2016 AFCI

mat'l. code		surface 58/ISO 1302		tolerance ISO 406 ISO 101		projection		product family			
-		✓		ISO 406 ISO 101				PCI_EXPRESS			
ltr	ecn no	dr	date	tolerances unless otherwise specified		MM		title			
				angles	linear	← →		PCI_EXPRESS_CARD_EDGE_GEN3 ASSEMBLY(SMT)			
				0°±2'		scale 2		dwg no		sheet 4 of 6	size
				engr	STONE_LI	2015/05/27		10061913		A4	
				chr	/	/		type CUSTOMER Drawing			
				appd	PM_ZHENG	2015/05/27					
sheet index	revision	P									
	sheet										



TAPE AND REEL
 PACKING
 RECOMMENDED FOR
 36PINS ONLY

DIMENSIONS					
POSITIONS	A	B	C	D REF.	E REF.
36 (10061913-xxxALF)	44.00	40.40	20.20	44.5	50.5
36	56.00	52.60	26.30	56.4	60.4
64	56.00	52.60	26.30	56.4	60.4
98	88.00	79.60	39.80	88.4	92.4

Amphenol FCI

© 2016 AFCI

mat'l. code		surface 58		tolerance		projection		product family				
-		ISO 1302		ISO 406 ISO		101		PCI_EXPRESS				
ltr	ecn no	dr	date	tolerances unless otherwise specified				title				
				angles		.X±.3		 PCI_EXPRESS_CARD_EDGE_GEN3 ASSEMBLY(SMT)				
				linear		.XX±.20						
				0°±2°		XXX±.10						
		dr	STONE_LI	2015/05/27			scale 1		dwg no		sheet 5 of 6	size
		engr	STONE_LI	2015/05/27					10061913		A4	
		chr	/	/					type		CUSTOMER Drawing	
sheet index	revision sheet	P										

1 For PCI EXPRESS SMT TYPE 36P ONLY.

2. Material :

- 2.1 Reel :
 - 2.1.1 Plastic hub : High Impact Polystyrene
 - 2.1.2 Cover tape : PE
 - 2.1.3 Carrier tape : ABS
- 2.2 Waterproof bag : PE
- 2.3 Desiccative : Silica Gel
- 2.4 Carton : Corrugated paper
- 2.5 Baffle : E.P.E
- 2.6 Angle paperboard : Corrugated paper

3. Dimension :

- 3.1 Reel :
 - 3.1.1 Plastic hub : $\phi 330 \times T50.5$ mm
 - 3.1.2 Cover tape : $5690(L) \times 37.4(W)$ mm
 - 3.1.3 Carrier tape : $5640(L) \times 44(W)$ mm
- 3.2 Waterproof bag : $600(H) \times 465(W) \times 0.06(T)$ mm
- 3.3 Desiccative : 25 gram / Package
- 3.4 Carton : $380(L) \times 380(W) \times 300(H)$ mm
- 3.5 Baffle (1): $370(L) \times 370(W) \times 15(H)$ mm
- 3.6 Baffle (2): $355(L) \times 252(W) \times 15(H)$ mm
- 3.7 Angle paperboard : $252(H)$

4. Quantity :

- 4.1 250 Pcs / Reel
- 4.2 1250 Pcs / Carton

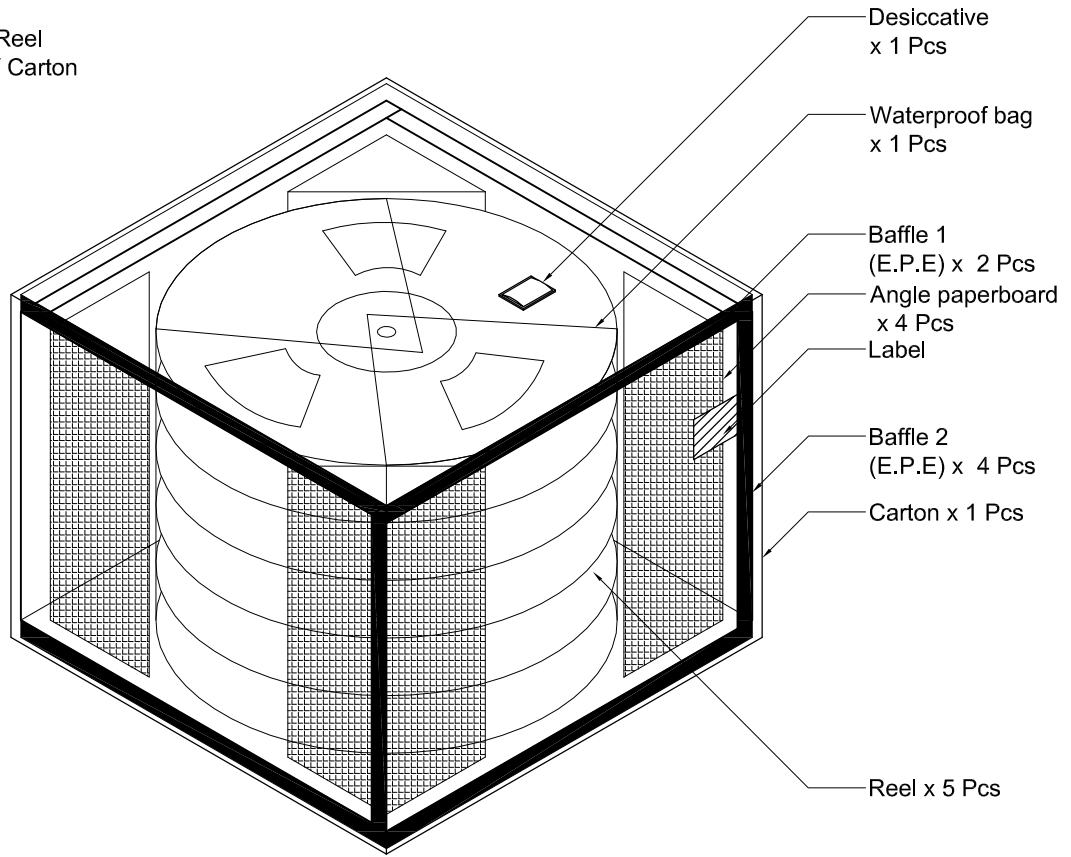

Amphenol FCI

© 2016 AFCI

mat'l. code		surface 58/ISO 1302 ✓		tolerance ISO 406 ISO 101		projection		product family PCI_EXPRESS				
ltr	ecn no	dr	date	tolerances unless otherwise specified				MM	title			
				angles	linear	.X±.3 .XX±.20 XXX±.10			PCI_EXPRESS_CARD_EDGE_GEN3 ASSEMBLY(SMT)			
				0°±2'	dr	STONE_LI	2015/05/27	Amphenol FCI	dwg no		sheet 6 of 6	size
				engr	STONE_LI	2015/05/27	10061913		A4			
				chr	/	/	type		CUSTOMER Drawing			
				appd	PM_ZHENG	2015/05/27						
sheet index	revision sheet	P										

Компания «Life Electronics» занимается поставками электронных компонентов импортного и отечественного производства от производителей и со складов крупных дистрибьюторов Европы, Америки и Азии.

С конца 2013 года компания активно расширяет линейку поставок компонентов по направлению коаксиальный кабель, кварцевые генераторы и конденсаторы (керамические, пленочные, электролитические), за счёт заключения дистрибьюторских договоров

Мы предлагаем:

- Конкурентоспособные цены и скидки постоянным клиентам.
- Специальные условия для постоянных клиентов.
- Подбор аналогов.
- Поставку компонентов в любых объемах, удовлетворяющих вашим потребностям.
- Приемлемые сроки поставки, возможна ускоренная поставка.
- Доставку товара в любую точку России и стран СНГ.
- Комплексную поставку.
- Работу по проектам и поставку образцов.
- Формирование склада под заказчика.
- Сертификаты соответствия на поставляемую продукцию (по желанию клиента).
- Тестирование поставляемой продукции.
- Поставку компонентов, требующих военную и космическую приемку.
- Входной контроль качества.
- Наличие сертификата ISO.

В составе нашей компании организован Конструкторский отдел, призванный помогать разработчикам, и инженерам.

Конструкторский отдел помогает осуществить:

- Регистрацию проекта у производителя компонентов.
- Техническую поддержку проекта.
- Защиту от снятия компонента с производства.
- Оценку стоимости проекта по компонентам.
- Изготовление тестовой платы монтаж и пусконаладочные работы.



Тел: +7 (812) 336 43 04 (многоканальный)

Email: org@lifeelectronics.ru