

FEATURES

- Overvoltage protection up to -55 V and $+55\text{ V}$
- Power-off protection up to -55 V and $+55\text{ V}$
- Overvoltage detection on source pins
- Interrupt flags indicate fault status
- Low on resistance: $10\ \Omega$ (typical)
- On-resistance flatness of $0.5\ \Omega$ (maximum)
- 6 kV human body model (HBM) ESD rating
- Latch-up immune under any circumstance
- Known state without digital inputs present
- V_{SS} to V_{DD} analog signal range
 - $\pm 5\text{ V}$ to $\pm 22\text{ V}$ dual supply operation
 - 8 V to 44 V single-supply operation
- Fully specified at $\pm 15\text{ V}$, $\pm 20\text{ V}$, $+12\text{ V}$, and $+36\text{ V}$

APPLICATIONS

- Analog input/output modules
- Process control/distributed control systems
- Data acquisition
- Instrumentation
- Avionics
- Automatic test equipment
- Communication systems
- Relay replacement

GENERAL DESCRIPTION

The [ADG5436F](#) is an analog multiplexer, containing two independently selectable single-pole, double-throw (SPDT) switches. An EN input is used to disable all the switches. For use in multiplexer applications, both switches exhibit break-before-make switching action.

Each channel conducts equally well in both directions when on, and each switch has an input signal range that extends to the supplies. The digital inputs are compatible with 3 V logic inputs over the full operating supply range.

When no power supplies are present, the switch remains in the off condition, and the channel inputs are high impedance. Under normal operating conditions, if the analog input signal level on any Sxx pin exceeds V_{DD} or V_{SS} by a threshold voltage, V_T , the channel turns off and that Sxx pin becomes high impedance. If the channel is on, the drain pin reacts according to the drain response (DR) input pin. If the DR pin is left floating or pulled high, the drain remains high impedance and floats. If the DR pin is pulled low, the drain pulls to the exceeded rail. Input signal levels of up to $+55\text{ V}$ or -55 V relative to ground are blocked, in both the powered and unpowered conditions. The low on

Rev. C

[Document Feedback](#)

Information furnished by Analog Devices is believed to be accurate and reliable. However, no responsibility is assumed by Analog Devices for its use, nor for any infringements of patents or other rights of third parties that may result from its use. Specifications subject to change without notice. No license is granted by implication or otherwise under any patent or patent rights of Analog Devices. Trademarks and registered trademarks are the property of their respective owners.

FUNCTIONAL BLOCK DIAGRAM

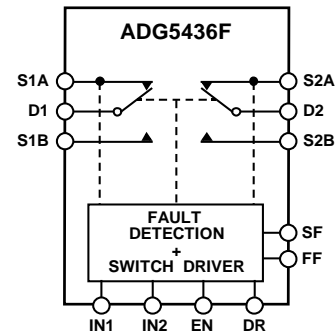

NOTES
1. SWITCHES SHOWN FOR A LOGIC 1 INPUT.

Figure 1.

12882-001

resistance of the [ADG5436F](#), combined with the on-resistance flatness over a significant portion of the signal range, makes it an ideal solution for data acquisition and gain switching applications where excellent linearity and low distortion are critical.

Note that, throughout this data sheet, the dual function pin names are referenced only by the relevant function where applicable. See the Pin Configurations and Function Descriptions section for full pin names and function descriptions.

PRODUCT HIGHLIGHTS

1. Source pins are protected against voltages greater than the supply rails, up to -55 V and $+55\text{ V}$.
2. Source pins are protected against voltages between -55 V and $+55\text{ V}$ in an unpowered state.
3. Overvoltage detection with digital output indicates the operating state of the switches.
4. Trench isolation guards against latch-up.
5. Optimized for low on resistance and on-resistance flatness.
6. The [ADG5436F](#) operates from a dual supply of $\pm 5\text{ V}$ up to $\pm 22\text{ V}$, or a single power supply of 8 V up to 44 V.

TABLE OF CONTENTS

Features	1	Test Circuits.....	20
Applications.....	1	Terminology.....	24
Functional Block Diagram	1	Theory of Operation	26
General Description	1	Switch Architecture.....	26
Product Highlights	1	Fault Protection	27
Revision History	2	Applications Information	28
Specifications.....	3	Power Supply Rails	28
±15 V Dual Supply	3	Power Supply Sequencing Protection	28
±20 V Dual Supply	5	Signal Range.....	28
12 V Single Supply.....	7	Low Impedance Channel Protection	28
36 V Single Supply.....	9	Power Supply Recommendations.....	28
Continuous Current per Channel, Sxx or Dx.....	11	High Voltage Surge Suppression	28
Absolute Maximum Ratings.....	12	Intelligent Fault Detection	29
ESD Caution.....	12	Large Voltage, High Frequency Signals.....	29
Pin Configurations and Function Descriptions	13	Outline Dimensions	30
Truth Tables for Switches	14	Ordering Guide	30
Typical Performance Characteristics	15		

REVISION HISTORY

10/2017—Rev. B to Rev. C

Changes to Fault Drain Leakage Current With Overvoltage Parameter, Table 1.....	3
Changes to Fault Drain Leakage Current With Overvoltage Parameter, Table 2.....	7
Changes to Fault Drain Leakage Current With Overvoltage Parameter, Table 4	9
Updated Outline Dimensions	30
Changes to Ordering Guide	30

1/2016—Rev. A to Rev. B

Changes to Table 1.....	3
Changes to Table 2.....	5
Changes to Table 3.....	7
Changes to Table 4.....	9
Changes to ESD Performance Section.....	26

5/2015—Rev. 0 to Rev. A

Added 16-Lead LFCSP Package	Universal
Changes to Table 1.....	3
Changes to Table 2.....	5
Changes to Table 3.....	7
Changes to Table 4.....	9
Changes to Table 5.....	11
Changes to Table 6.....	12
Added Figure 3; Renumbered Sequentially	13
Changes to Table 7.....	13
Added Figure 53	30
Updated Outline Dimensions.....	30
Changes to Ordering Guide	30

1/2015—Revision 0: Initial Version

SPECIFICATIONS

±15 V DUAL SUPPLY

$V_{DD} = 15\text{ V} \pm 10\%$, $V_{SS} = -15\text{ V} \pm 10\%$, $GND = 0\text{ V}$, $C_{DECOUPLING} = 0.1\text{ }\mu\text{F}$, unless otherwise noted.

Table 1.

Parameter	+25°C	-40°C to +85°C	-40°C to +125°C	Unit	Test Conditions/Comments
ANALOG SWITCH					
Analog Signal Range			V_{DD} to V_{SS}	V	$V_{DD} = 13.5\text{ V}$, $V_{SS} = -13.5\text{ V}$, see Figure 30
On Resistance, R_{ON}	10			Ω typ	Voltage on the Sxx pins ($V_S = \pm 10\text{ V}$, $I_S = -10\text{ mA}$)
	11.2	14	16.5	Ω max	
	9.5			Ω typ	$V_S = \pm 9\text{ V}$, $I_S = -10\text{ mA}$
	10.7	13.5	16	Ω max	
On-Resistance Match Between Channels, ΔR_{ON}	0.15			Ω typ	$V_S = \pm 10\text{ V}$, $I_S = -10\text{ mA}$
	0.65	0.8	0.95	Ω max	
	0.15			Ω typ	$V_S = \pm 9\text{ V}$, $I_S = -10\text{ mA}$
	0.6	0.7	0.8	Ω max	
On-Resistance Flatness, $R_{FLAT(ON)}$	0.6			Ω typ	$V_S = \pm 10\text{ V}$, $I_S = -10\text{ mA}$
	0.9	1.1	1.1	Ω max	
	0.1			Ω typ	$V_S = \pm 9\text{ V}$, $I_S = -10\text{ mA}$
	0.4	0.5	0.5	Ω max	
Threshold Voltage, V_T	0.7			V typ	See Figure 26
LEAKAGE CURRENTS					
Source Off Leakage, I_S (Off)	± 0.1			nA typ	$V_{DD} = 16.5\text{ V}$, $V_{SS} = -16.5\text{ V}$
	± 1.5	± 5.0	± 21	nA max	$V_S = \pm 10\text{ V}$, voltage on the Dx pin ($V_D = \mp 10\text{ V}$), see Figure 31
Drain Off Leakage, I_D (Off)	± 0.1			nA typ	$V_S = \pm 10\text{ V}$, $V_D = \mp 10\text{ V}$, see Figure 31
	± 1.5	± 7.0	± 25	nA max	
Channel On Leakage, I_D (On), I_S (On)	± 0.5			nA typ	$V_S = V_D = \pm 10\text{ V}$, see Figure 32
	± 1.5	± 5.0	± 21	nA max	
FAULT					
Source Leakage Current, I_S With Overvoltage			± 72	μA typ	$V_{DD} = 16.5\text{ V}$, $V_{SS} = -16.5\text{ V}$, $GND = 0\text{ V}$, $V_S = \pm 55\text{ V}$, see Figure 35
Power Supplies Grounded or Floating			± 49	μA typ	$V_{DD} = 0\text{ V}$ or floating, $V_{SS} = 0\text{ V}$ or floating, $GND = 0\text{ V}$, $EN = 0\text{ V}$ or floating, $INx = 0\text{ V}$ or floating, $V_S = \pm 55\text{ V}$, see Figure 36
Drain Leakage Current, I_D With Overvoltage	± 2.0			nA typ	DR = floating or $> 2\text{ V}$
	± 20	± 30	± 65	nA max	$V_{DD} = 16.5\text{ V}$, $V_{SS} = -16.5\text{ V}$, $GND = 0\text{ V}$, $V_S = \pm 55\text{ V}$, see Figure 35
Power Supplies Grounded	± 10			nA typ	$V_{DD} = 0\text{ V}$, $V_{SS} = 0\text{ V}$, $GND = 0\text{ V}$, $INx = 0\text{ V}$ or floating, $V_S = \pm 55\text{ V}$, $EN = 0\text{ V}$, see Figure 36
	± 30	± 50	± 100	nA max	
Power Supplies Floating	± 10	± 10	± 10	μA typ	$V_{DD} = \text{floating}$, $V_{SS} = \text{floating}$, $GND = 0\text{ V}$, $V_S = \pm 55\text{ V}$, $EN = 0\text{ V}$, see Figure 36
DIGITAL INPUTS/OUTPUTS					
Input Voltage High, V_{INH}			2.0	V min	
Input Voltage Low, V_{INL}			0.8	V max	
Input Current, I_{INL} or I_{INH}	± 0.7			μA typ	$V_{IN} = V_{GND}$ or V_{DD}
			± 1.2	μA max	
Digital Input Capacitance, C_{IN}	6.0			pF typ	
Output Voltage High, V_{OH}	2.0			V min	
Output Voltage Low, V_{OL}	0.8			V max	

Parameter	+25°C	-40°C to +85°C	-40°C to +125°C	Unit	Test Conditions/Comments
DYNAMIC CHARACTERISTICS¹					
Transition Time, $t_{\text{TRANSITION}}$	400			ns typ	$R_L = 300 \Omega$, $C_L = 35 \text{ pF}$
	540	555	570	ns max	$V_S = 10 \text{ V}$, see Figure 46
$t_{\text{ON}} (\text{EN})$	435			ns typ	$R_L = 300 \Omega$, $C_L = 35 \text{ pF}$
	515	530	550	ns max	$V_S = 10 \text{ V}$, see Figure 45
$t_{\text{OFF}} (\text{EN})$	165			ns typ	$R_L = 300 \Omega$, $C_L = 35 \text{ pF}$
	210	215	220	ns max	$V_S = 10 \text{ V}$, see Figure 45
Break-Before-Make Time Delay, t_D	320			ns typ	$R_L = 300 \Omega$, $C_L = 35 \text{ pF}$
			190	ns min	$V_S = 10 \text{ V}$, see Figure 44
Overvoltage Response Time, t_{RESPONSE}	510			ns typ	$R_L = 1 \text{ k}\Omega$, $C_L = 2 \text{ pF}$, see Figure 39
	680	725	750	ns max	
Overvoltage Recovery Time, t_{RECOVERY}	820			ns typ	$R_L = 1 \text{ k}\Omega$, $C_L = 2 \text{ pF}$, see Figure 40
	1100	1150	1200	ns max	
Interrupt Flag Response Time, t_{DIGRESP}	85		115	ns typ	$C_L = 12 \text{ pF}$, see Figure 41
Interrupt Flag Recovery Time, t_{DIGREC}	60		85	μs typ	$C_L = 12 \text{ pF}$, see Figure 42
	600			ns typ	$C_L = 12 \text{ pF}$, $R_{\text{PULLUP}} = 1 \text{ k}\Omega$, see Figure 43
Charge Injection, Q_{INJ}	-724			pC typ	$V_S = 0 \text{ V}$, $R_S = 0 \Omega$, $C_L = 1 \text{ nF}$, see Figure 47
Off Isolation	-71			dB typ	$R_L = 50 \Omega$, $C_L = 5 \text{ pF}$, $f = 1 \text{ MHz}$, see Figure 33
Channel-to-Channel Crosstalk	-73			dB typ	$R_L = 50 \Omega$, $C_L = 5 \text{ pF}$, $f = 1 \text{ MHz}$, see Figure 34
Total Harmonic Distortion Plus Noise, THD + N	0.001			% typ	$R_L = 10 \text{ k}\Omega$, $V_S = 15 \text{ V p-p}$, $f = 20 \text{ Hz to } 20 \text{ kHz}$, see Figure 38
-3 dB Bandwidth	169			MHz typ	$R_L = 50 \Omega$, $C_L = 5 \text{ pF}$, see Figure 37
Insertion Loss	-0.8			dB typ	$R_L = 50 \Omega$, $C_L = 5 \text{ pF}$, $f = 1 \text{ MHz}$, see Figure 37
Source Capacitance (C_S), Off	12			pF typ	$V_S = 0 \text{ V}$, $f = 1 \text{ MHz}$
Drain Capacitance (C_D), Off	24			pF typ	$V_S = 0 \text{ V}$, $f = 1 \text{ MHz}$
C_D (On), C_S (On)	37			pF typ	$V_S = 0 \text{ V}$, $f = 1 \text{ MHz}$
POWER REQUIREMENTS					
					$V_{\text{DD}} = 16.5 \text{ V}$, $V_{\text{SS}} = -16.5 \text{ V}$, $\text{GND} = 0 \text{ V}$, digital inputs = 0 V, 5 V, or V_{DD}
Normal Mode					
I_{DD}	0.9			mA typ	
	1.2		1.3	mA max	
I_{GND}	0.4			mA typ	
	0.55		0.6	mA max	
I_{SS}	0.5			mA typ	
	0.65		0.7	mA max	
Fault Mode					$V_S = \pm 55 \text{ V}$
I_{DD}	1.2			mA typ	
	1.6		1.8	mA max	
I_{GND}	0.8			mA typ	
	1.0		1.1	mA max	
I_{SS}	0.5			mA typ	Digital inputs = 5 V
	1.0		1.8	mA max	$V_S = \pm 55 \text{ V}$, $V_D = 0 \text{ V}$
$V_{\text{DD}}/V_{\text{SS}}$			± 5	V min	$\text{GND} = 0 \text{ V}$
			± 22	V max	$\text{GND} = 0 \text{ V}$

¹ Guaranteed by design. Not subject to production test.

±20 V DUAL SUPPLY

$V_{DD} = 20\text{ V} \pm 10\%$, $V_{SS} = -20\text{ V} \pm 10\%$, $GND = 0\text{ V}$, $C_{DECOUPLING} = 0.1\text{ }\mu\text{F}$, unless otherwise noted.

Table 2.

Parameter	+25°C	-40°C to +85°C	-40°C to +125°C	Unit	Test Conditions/Comments
ANALOG SWITCH					
Analog Signal Range			V_{DD} to V_{SS}	V	$V_{DD} = 18\text{ V}$, $V_{SS} = -18\text{ V}$, see Figure 30
On Resistance, R_{ON}	10			Ω typ	$V_S = \pm 15\text{ V}$, $I_S = -10\text{ mA}$
	11.5	14.5	16.5	Ω max	
	9.5			Ω typ	$V_S = \pm 13.5\text{ V}$, $I_S = -10\text{ mA}$
	11	14	16.5	Ω max	
On-Resistance Match Between Channels, ΔR_{ON}	0.15			Ω typ	$V_S = \pm 15\text{ V}$, $I_S = -10\text{ mA}$
	0.65	0.8	0.95	Ω max	
	0.15			Ω typ	$V_S = \pm 13.5\text{ V}$, $I_S = -10\text{ mA}$
	0.6	0.7	0.8	Ω max	
On-Resistance Flatness, $R_{FLAT(ON)}$	1.0			Ω typ	$V_S = \pm 15\text{ V}$, $I_S = -10\text{ mA}$
	1.4	1.5	1.5	Ω max	
	0.1			Ω typ	$V_S = \pm 13.5\text{ V}$, $I_S = -10\text{ mA}$
	0.4	0.5	0.5	Ω max	
Threshold Voltage, V_T	0.7			V typ	See Figure 26
LEAKAGE CURRENTS					
Source Off Leakage, I_S (Off)	± 0.1			nA typ	$V_{DD} = 22\text{ V}$, $V_{SS} = -22\text{ V}$
	± 1.5	± 5.0	± 21	nA max	$V_S = \pm 15\text{ V}$, $V_D = \pm 15\text{ V}$, see Figure 31
Drain Off Leakage, I_D (Off)	± 0.1			nA typ	$V_S = \pm 15\text{ V}$, $V_D = \pm 15\text{ V}$, see Figure 31
	± 1.5	± 7.0	± 25	nA max	
Channel On Leakage, I_D (On), I_S (On)	± 0.5			nA typ	$V_S = V_D = \pm 15\text{ V}$, see Figure 32
	± 1.5	± 5.0	± 21	nA max	
FAULT					
Source Leakage Current, I_S With Overvoltage			± 84	μA typ	$V_{DD} = +22\text{ V}$, $V_{SS} = -22\text{ V}$, $GND = 0\text{ V}$, $V_S = \pm 55\text{ V}$, see Figure 35
Power Supplies Grounded or Floating			± 49	μA typ	$V_{DD} = 0\text{ V}$ or floating, $V_{SS} = 0\text{ V}$ or floating, $GND = 0\text{ V}$, $EN = 0\text{ V}$ or floating, $INx = 0\text{ V}$ or floating, $V_S = \pm 55\text{ V}$, see Figure 36
Drain Leakage Current, I_D With Overvoltage	± 5.0			nA typ	$DR = \text{floating or } > 2\text{ V}$ $V_{DD} = +22\text{ V}$, $V_{SS} = -22\text{ V}$, $GND = 0\text{ V}$, $INx = 0\text{ V}$ or floating, $V_S = \pm 55\text{ V}$, see Figure 35
Power Supplies Grounded	± 1.0 ± 10	± 1.0	± 1.0	μA max nA typ	$V_{DD} = 0\text{ V}$, $V_{SS} = 0\text{ V}$, $GND = 0\text{ V}$, $V_S =$ $\pm 55\text{ V}$, $EN = 0\text{ V}$, see Figure 36
Power Supplies Floating	± 30 ± 10	± 50 ± 10	± 100 ± 10	nA max μA typ	$V_{DD} = \text{floating}$, $V_{SS} = \text{floating}$, $GND =$ 0 V , $V_S = \pm 55\text{ V}$, $EN = 0\text{ V}$, see Figure 36
DIGITAL INPUTS					
Input Voltage High, V_{INH}			2.0	V min	$V_{IN} = V_{GND}$ or V_{DD}
Input Voltage Low, V_{INL}			0.8	V max	
Input Current, I_{INL} or I_{INH}	0.7			μA typ	
			1.2	μA max	
Digital Input Capacitance, C_{IN}	6.0			pF typ	
Output Voltage High, V_{OH}	2.0			V min	
Output Voltage Low, V_{OL}	0.8			V max	

Parameter	+25°C	-40°C to +85°C	-40°C to +125°C	Unit	Test Conditions/Comments
DYNAMIC CHARACTERISTICS¹					
Transition Time, $t_{\text{TRANSITION}}$	405			ns typ	$R_L = 300 \Omega$, $C_L = 35 \text{ pF}$
	540	555	570	ns max	$V_S = 10 \text{ V}$, see Figure 46
$t_{\text{ON}} (\text{EN})$	430			ns typ	$R_L = 300 \Omega$, $C_L = 35 \text{ pF}$
	535	560	585	ns max	$V_S = 10 \text{ V}$, see Figure 45
$t_{\text{OFF}} (\text{EN})$	170			ns typ	$R_L = 300 \Omega$, $C_L = 35 \text{ pF}$
	205	210	215	ns max	$V_S = 10 \text{ V}$, see Figure 45
Break-Before-Make Time Delay, t_D	330			ns typ	$R_L = 300 \Omega$, $C_L = 35 \text{ pF}$
			205	ns min	$V_S = 10 \text{ V}$, see Figure 44
Overvoltage Response Time, t_{RESPONSE}	430			ns typ	$R_L = 1 \text{ k}\Omega$, $C_L = 2 \text{ pF}$, see Figure 39
	560	605	630	ns max	
Overvoltage Recovery Time, t_{RECOVERY}	930			ns typ	$R_L = 1 \text{ k}\Omega$, $C_L = 2 \text{ pF}$, see Figure 40
	1300	1500	1700	ns max	
Interrupt Flag Response Time, t_{DIGRESP}	85		115	ns typ	$C_L = 12 \text{ pF}$, see Figure 41
Interrupt Flag Recovery Time, t_{DIGREC}	60		85	μs typ	$C_L = 12 \text{ pF}$, see Figure 42
	600			ns typ	$C_L = 12 \text{ pF}$, $R_{\text{PULLUP}} = 1 \text{ k}\Omega$, see Figure 43
Charge Injection, Q_{INJ}	-737			pC typ	$V_S = 0 \text{ V}$, $R_S = 0 \Omega$, $C_L = 1 \text{ nF}$, see Figure 47
Off Isolation	-72			dB typ	$R_L = 50 \Omega$, $C_L = 5 \text{ pF}$, $f = 1 \text{ MHz}$, see Figure 33
Channel-to-Channel Crosstalk	-73			dB typ	$R_L = 50 \Omega$, $C_L = 5 \text{ pF}$, $f = 1 \text{ MHz}$, see Figure 34
Total Harmonic Distortion Plus Noise, THD + N	0.001			% typ	$R_L = 10 \text{ k}\Omega$, $V_S = 20 \text{ V p-p}$, $f = 20 \text{ Hz}$ to 20 kHz , see Figure 38
-3 dB Bandwidth	171			MHz typ	$R_L = 50 \Omega$, $C_L = 5 \text{ pF}$, see Figure 37
Insertion Loss	-0.8			dB typ	$R_L = 50 \Omega$, $C_L = 5 \text{ pF}$, $f = 1 \text{ MHz}$, see Figure 37
C_S (Off)	11			pF typ	$V_S = 0 \text{ V}$, $f = 1 \text{ MHz}$
C_D (Off)	23			pF typ	$V_S = 0 \text{ V}$, $f = 1 \text{ MHz}$
C_D (On), C_S (On)	36			pF typ	$V_S = 0 \text{ V}$, $f = 1 \text{ MHz}$
POWER REQUIREMENTS					
$V_{\text{DD}} = 22 \text{ V}$, $V_{\text{SS}} = -22 \text{ V}$, digital inputs = 0 V, 5 V, or V_{DD}					
Normal Mode					
I_{DD}	0.9			mA typ	
	1.2		1.3	mA max	
I_{GND}	0.4			mA typ	
	0.55		0.6	mA max	
I_{SS}	0.5			mA typ	
	0.65		0.7	mA max	
Fault Mode					$V_S = \pm 55 \text{ V}$
I_{DD}	1.2			mA typ	
	1.6		1.8	mA max	
I_{GND}	0.8			mA typ	
	1.0		1.1	mA max	
I_{SS}	0.5			mA typ	Digital inputs = 5 V
	1.0		1.8	mA max	$V_S = \pm 55 \text{ V}$, $V_D = 0 \text{ V}$
$V_{\text{DD}}/V_{\text{SS}}$			± 5	V min	GND = 0 V
			± 22	V max	GND = 0 V

¹ Guaranteed by design. Not subject to production test.

12 V SINGLE SUPPLY

$V_{DD} = 12\text{ V} \pm 10\%$, $V_{SS} = 0\text{ V}$, $GND = 0\text{ V}$, $C_{DECOUPLING} = 0.1\ \mu\text{F}$, unless otherwise noted.

Table 3.

Parameter	+25°C	-40°C to +85°C	-40°C to +125°C	Unit	Test Conditions/Comments
ANALOG SWITCH					
Analog Signal Range			0 V to V_{DD}	V	$V_{DD} = 10.8\text{ V}$, $V_{SS} = 0\text{ V}$, see Figure 30
On Resistance, R_{ON}	22			Ω typ	$V_S = 0\text{ V to }10\text{ V}$, $I_S = -10\text{ mA}$
	24.5	31	37	Ω max	
	10			Ω typ	$V_S = 3.5\text{ V to }8.5\text{ V}$, $I_S = -10\text{ mA}$
	11.2	14	16.5	Ω max	
On-Resistance Match Between Channels, ΔR_{ON}	0.2			Ω typ	$V_S = 0\text{ V to }10\text{ V}$, $I_S = -10\text{ mA}$
	0.65	0.8	0.95	Ω max	
	0.2			Ω typ	$V_S = 3.5\text{ V to }8.5\text{ V}$, $I_S = -10\text{ mA}$
	0.65	0.8	0.95	Ω max	
On-Resistance Flatness, $R_{FLAT(ON)}$	12.5			Ω typ	$V_S = 0\text{ V to }10\text{ V}$, $I_S = -10\text{ mA}$
	14.5	19	23	Ω max	
	0.6			Ω typ	$V_S = 3.5\text{ V to }8.5\text{ V}$, $I_S = -10\text{ mA}$
	0.9	1.1	1.3	Ω max	
Threshold Voltage, V_T	0.7			V typ	See Figure 26
LEAKAGE CURRENTS					
Source Off Leakage, I_S (Off)	± 0.1			nA typ	$V_{DD} = 13.2\text{ V}$, $V_{SS} = 0\text{ V}$
	± 1.5	± 5.0	± 21	nA max	$V_S = 1\text{ V}/10\text{ V}$, $V_D = 10\text{ V}/1\text{ V}$, see Figure 31
Drain Off Leakage, I_D (Off)	± 0.1			nA typ	$V_S = 1\text{ V}/10\text{ V}$, $V_D = 10\text{ V}/1\text{ V}$, see Figure 31
	± 1.5	± 7.0	± 25	nA max	
Channel On Leakage, I_D (On), I_S (On)	± 0.5			nA typ	$V_S = V_D = 1\text{ V}/10\text{ V}$, see Figure 32
	± 1.5	± 5.0	± 21	nA max	
FAULT					
Source Leakage Current, I_S With Overvoltage			± 65	μA typ	$V_{DD} = 13.2\text{ V}$, $V_{SS} = 0\text{ V}$, $GND = 0\text{ V}$, $V_S = \pm 55\text{ V}$, see Figure 35
Power Supplies Grounded or Floating			± 49	μA typ	$V_{DD} = 0\text{ V}$ or floating, $V_{SS} = 0\text{ V}$ or floating, $GND = 0\text{ V}$, $EN = 0\text{ V}$ or floating, $V_S = \pm 55\text{ V}$, see Figure 36
Drain Leakage Current, I_D With Overvoltage	± 2.0			nA typ	$DR = \text{floating or } >2\text{ V}$ $V_{DD} = 13.2\text{ V}$, $V_{SS} = 0\text{ V}$, $GND = 0\text{ V}$, $INx = 0\text{ V}$ or floating, $V_S = \pm 55\text{ V}$, see Figure 35
Power Supplies Grounded	± 20 ± 10	± 30	± 65	nA max nA typ	$V_{DD} = 0\text{ V}$, $V_{SS} = 0\text{ V}$, $GND = 0\text{ V}$, $V_S = \pm 55\text{ V}$, $EN = 0\text{ V}$, see Figure 36
Power Supplies Floating	± 30 ± 10	± 50 ± 10	± 100 ± 10	nA max μA typ	$V_{DD} = \text{floating}$, $V_{SS} = \text{floating}$, $GND = 0\text{ V}$, $V_S = \pm 55\text{ V}$, $EN = 0\text{ V}$, see Figure 36
DIGITAL INPUTS					
Input Voltage High, V_{INH}			2.0	V min	$V_{IN} = V_{GND}$ or V_{DD}
Input Voltage Low, V_{INL}			0.8	V max	
Input Current, I_{INL} or I_{INH}	0.7		1.2	μA typ μA max	
Digital Input Capacitance, C_{IN}	6.0			pF typ	
Output Voltage High, V_{OH}	2.0			V min	
Output Voltage Low, V_{OL}	0.8			V max	

Parameter	+25°C	-40°C to +85°C	-40°C to +125°C	Unit	Test Conditions/Comments
DYNAMIC CHARACTERISTICS¹					
Transition Time, $t_{\text{TRANSITION}}$	400			ns typ	$R_L = 300 \Omega$, $C_L = 35 \text{ pF}$
	545	560	570	ns max	$V_S = 10 \text{ V}$, see Figure 46
$t_{\text{ON}} (\text{EN})$	435			ns typ	$R_L = 300 \Omega$, $C_L = 35 \text{ pF}$
	515	530	550	ns max	$V_S = 8 \text{ V}$, see Figure 45
$t_{\text{OFF}} (\text{EN})$	185			ns typ	$R_L = 300 \Omega$, $C_L = 35 \text{ pF}$
	230	240	250	ns max	$V_S = 8 \text{ V}$, see Figure 45
Break-Before-Make Time Delay, t_D	300			ns typ	$R_L = 300 \Omega$, $C_L = 35 \text{ pF}$
			180	ns min	$V_S = 8 \text{ V}$, see Figure 44
Overvoltage Response Time, t_{RESPONSE}	590			ns typ	$R_L = 1 \text{ k}\Omega$, $C_L = 2 \text{ pF}$, see Figure 39
	770	830	870	ns max	
Overvoltage Recovery Time, t_{RECOVERY}	680			ns typ	$R_L = 1 \text{ k}\Omega$, $C_L = 2 \text{ pF}$, see Figure 40
	850	910	1000	ns max	
Interrupt Flag Response Time, t_{DIGRESP}	85		115	ns typ	$C_L = 12 \text{ pF}$, see Figure 41
Interrupt Flag Recovery Time, t_{DIGREC}	60		85	μs typ	$C_L = 12 \text{ pF}$, see Figure 42
	600			ns typ	$C_L = 12 \text{ pF}$, $R_{\text{PULLUP}} = 1 \text{ k}\Omega$, see Figure 43
Charge Injection, Q_{INJ}	-341			pC typ	$V_S = 6 \text{ V}$, $R_S = 0 \Omega$, $C_L = 1 \text{ nF}$, see Figure 47
Off Isolation	-68			dB typ	$R_L = 50 \Omega$, $C_L = 5 \text{ pF}$, $f = 1 \text{ MHz}$, see Figure 33
Channel-to-Channel Crosstalk	-70			dB typ	$R_L = 50 \Omega$, $C_L = 5 \text{ pF}$, $f = 1 \text{ MHz}$, see Figure 34
Total Harmonic Distortion Plus Noise, THD + N	0.007			% typ	$R_L = 10 \text{ k}\Omega$, $V_S = 6 \text{ V p-p}$, $f = 20 \text{ Hz}$ to 20 kHz , see Figure 38
-3 dB Bandwidth	152			MHz typ	$R_L = 50 \Omega$, $C_L = 5 \text{ pF}$, see Figure 37
Insertion Loss	-0.8			dB typ	$R_L = 50 \Omega$, $C_L = 5 \text{ pF}$, $f = 1 \text{ MHz}$, see Figure 37
C_S (Off)	14			pF typ	$V_S = 6 \text{ V}$, $f = 1 \text{ MHz}$
C_D (Off)	30			pF typ	$V_S = 6 \text{ V}$, $f = 1 \text{ MHz}$
C_D (On), C_S (On)	41			pF typ	$V_S = 6 \text{ V}$, $f = 1 \text{ MHz}$
POWER REQUIREMENTS					
$V_{\text{DD}} = 13.2 \text{ V}$, $V_{\text{SS}} = 0 \text{ V}$, digital inputs = 0 V , 5 V , or V_{DD}					
Normal Mode					
I_{DD}	0.9			mA typ	
	1.2		1.3	mA max	
I_{GND}	0.4			mA typ	
	0.55		0.6	mA max	
I_{SS}	0.5			mA typ	
	0.65		0.7	mA max	
Fault Mode					$V_S = \pm 55 \text{ V}$
I_{DD}	1.2			mA typ	
	1.6		1.8	mA max	
I_{GND}	0.8			mA typ	
	1.0		1.1	mA max	
I_{SS}	0.5			mA typ	Digital inputs = 5 V
	1.0		1.8	mA max	$V_S = \pm 55 \text{ V}$, $V_D = 0 \text{ V}$
V_{DD}			8	V min	$\text{GND} = 0 \text{ V}$
			44	V max	$\text{GND} = 0 \text{ V}$

¹ Guaranteed by design. Not subject to production test.

36 V SINGLE SUPPLY

$V_{DD} = 36\text{ V} \pm 10\%$, $V_{SS} = 0\text{ V}$, $GND = 0\text{ V}$, $C_{DECOUPLING} = 0.1\ \mu\text{F}$, unless otherwise noted.

Table 4.

Parameter	+25°C	-40°C to +85°C	-40°C to +125°C	Unit	Test Conditions/Comments
ANALOG SWITCH					
Analog Signal Range			0 V to V_{DD}	V	$V_{DD} = 32.4\text{ V}$, $V_{SS} = 0\text{ V}$, see Figure 30
On Resistance, R_{ON}	22			Ω typ	$V_S = 0\text{ V to }30\text{ V}$, $I_S = -10\text{ mA}$
	24.5	31	37	Ω max	
	10			Ω typ	$V_S = 4.5\text{ V to }28\text{ V}$, $I_S = -10\text{ mA}$
	11	14	16.5	Ω max	
On-Resistance Match Between Channels, ΔR_{ON}	0.15			Ω typ	$V_S = 0\text{ V to }30\text{ V}$, $I_S = -10\text{ mA}$
	0.65	0.8	0.95	Ω max	
	0.15			Ω typ	$V_S = 4.5\text{ V to }28\text{ V}$, $I_S = -10\text{ mA}$
	0.6	0.7	0.8	Ω max	
On-Resistance Flatness, $R_{FLAT(ON)}$	12.5			Ω typ	$V_S = 0\text{ V to }30\text{ V}$, $I_S = -10\text{ mA}$
	14.5	19	23	Ω max	
	0.1			Ω typ	$V_S = 4.5\text{ V to }28\text{ V}$, $I_S = -10\text{ mA}$
	0.4	0.5	0.5	Ω max	
Threshold Voltage, V_T	0.7			V typ	See Figure 26
LEAKAGE CURRENTS					
Source Off Leakage, I_S (Off)	± 0.1			nA typ	$V_{DD} = 39.6\text{ V}$, $V_{SS} = 0\text{ V}$
	± 1.5	± 5.0	± 21	nA max	$V_S = 1\text{ V}/30\text{ V}$, $V_D = 30\text{ V}/1\text{ V}$, see Figure 31
Drain Off Leakage, I_D (Off)	± 0.1			nA typ	$V_S = 1\text{ V}/30\text{ V}$, $V_D = 30\text{ V}/1\text{ V}$, see Figure 31
	± 1.5	± 7.0	± 25	nA max	
Channel On Leakage, I_D (On), I_S (On)	± 0.5			nA typ	$V_S = V_D = 1\text{ V}/30\text{ V}$, see Figure 32
	± 1.5	± 5.0	± 21	nA max	
FAULT					
Source Leakage Current, I_S With Overvoltage			± 60	μA typ	$V_{DD} = 39.6\text{ V}$, $V_{SS} = 0\text{ V}$, $GND = 0\text{ V}$, $I_{NX} = 0\text{ V}$ or floating, $V_S = +55\text{ V}$, -40 V , see Figure 35
Power Supplies Grounded or Floating			± 49	μA typ	$V_{DD} = 0\text{ V}$ or floating, $V_{SS} = 0\text{ V}$ or floating, $GND = 0\text{ V}$, $I_{NX} = 0\text{ V}$ or floating, $V_S = +55\text{ V}$, -40 V , see Figure 36
Drain Leakage Current, I_D With Overvoltage	± 2.0			nA typ	DR = floating or $>2\text{ V}$ $V_{DD} = 39.6\text{ V}$, $V_{SS} = 0\text{ V}$, $GND = 0\text{ V}$, $V_S = +55\text{ V}$, -40 V , see Figure 35
Power Supplies Grounded	± 20 ± 10	± 30	± 65	nA max nA typ	$V_{DD} = 0\text{ V}$, $V_{SS} = 0\text{ V}$, $GND = 0\text{ V}$, $V_S =$ $+55\text{ V}$, -40 V , $EN = 0\text{ V}$, see Figure 36
Power Supplies Floating	± 30 ± 10	± 50 ± 10	± 100 ± 10	nA max μA typ	$V_{DD} = \text{floating}$, $V_{SS} = \text{floating}$, $GND = 0\text{ V}$, $V_S = +55\text{ V}$, -40 V , $EN = 0\text{ V}$, see Figure 36
DIGITAL INPUTS					
Input Voltage High, V_{INH}			2.0	V min	$V_{IN} = V_{GND}$ or V_{DD}
Input Voltage Low, V_{INL}			0.8	V max	
Input Current, I_{INL} or I_{INH}	0.7			μA typ	
			1.2	μA max	
Digital Input Capacitance, C_{IN}	6.0			pF typ	
Output Voltage High, V_{OH}	2.0			V min	
Output Voltage Low, V_{OL}	0.8			V max	

Parameter	+25°C	-40°C to +85°C	-40°C to +125°C	Unit	Test Conditions/Comments
DYNAMIC CHARACTERISTICS¹					
Transition Time, $t_{\text{TRANSITION}}$	400			ns typ	$R_L = 300 \Omega$, $C_L = 35 \text{ pF}$
	540	555	570	ns max	$V_S = 10 \text{ V}$, see Figure 46
$t_{\text{ON}} (\text{EN})$	440			ns typ	$R_L = 300 \Omega$, $C_L = 35 \text{ pF}$
	520	540	560	ns max	$V_S = 18 \text{ V}$, see Figure 45
$t_{\text{OFF}} (\text{EN})$	160			ns typ	$R_L = 300 \Omega$, $C_L = 35 \text{ pF}$
	190	195	200	ns max	$V_S = 18 \text{ V}$, see Figure 45
Break-Before-Make Time Delay, t_D	330			ns typ	$R_L = 300 \Omega$, $C_L = 35 \text{ pF}$
			210	ns min	$V_S = 18 \text{ V}$, see Figure 44
Overvoltage Response Time, t_{RESPONSE}	260			ns typ	$R_L = 1 \text{ k}\Omega$, $C_L = 2 \text{ pF}$, see Figure 39
	340	360	385	ns max	
Overvoltage Recovery Time, t_{RECOVERY}	1500			ns typ	$R_L = 1 \text{ k}\Omega$, $C_L = 2 \text{ pF}$, see Figure 40
	2100	2400	2700	ns max	
Interrupt Flag Response Time, t_{DIGRESP}	85		115	ns typ	$C_L = 12 \text{ pF}$, see Figure 41
Interrupt Flag Recovery Time, t_{DIGREC}	60		85	μs typ	$C_L = 12 \text{ pF}$, see Figure 42
	600			ns typ	$C_L = 12 \text{ pF}$, $R_{\text{PULLUP}} = 1 \text{ k}\Omega$, see Figure 43
Charge Injection, Q_{INJ}	-627			pC typ	$V_S = 18 \text{ V}$, $R_S = 0 \Omega$, $C_L = 1 \text{ nF}$, see Figure 47
Off Isolation	-71			dB typ	$R_L = 50 \Omega$, $C_L = 5 \text{ pF}$, $f = 1 \text{ MHz}$, see Figure 33
Channel-to-Channel Crosstalk	-73			dB typ	$R_L = 50 \Omega$, $C_L = 5 \text{ pF}$, $f = 1 \text{ MHz}$, see Figure 34
Total Harmonic Distortion Plus Noise, THD + N	0.001			% typ	$R_L = 10 \text{ k}\Omega$, $V_S = 18 \text{ V}$ p-p, $f = 20 \text{ Hz}$ to 20 kHz , see Figure 38
-3 dB Bandwidth	173			MHz typ	$R_L = 50 \Omega$, $C_L = 5 \text{ pF}$, see Figure 37
Insertion Loss	-0.8			dB typ	$R_L = 50 \Omega$, $C_L = 5 \text{ pF}$, $f = 1 \text{ MHz}$, see Figure 37
C_S (Off)	11			pF typ	$V_S = 18 \text{ V}$, $f = 1 \text{ MHz}$
C_D (Off)	23			pF typ	$V_S = 18 \text{ V}$, $f = 1 \text{ MHz}$
C_D (On), C_S (On)	36			pF typ	$V_S = 18 \text{ V}$, $f = 1 \text{ MHz}$
POWER REQUIREMENTS					
Normal Mode					$V_{\text{DD}} = 39.6 \text{ V}$, $V_{\text{SS}} = 0 \text{ V}$, digital inputs = 0 V, 5 V, or V_{DD}
I_{DD}	0.9			mA typ	
	1.2		1.3	mA max	
I_{GND}	0.4			mA typ	
	0.55		0.6	mA max	
I_{SS}	0.5			mA typ	
	0.65		0.7	mA max	
Fault Mode					$V_S = +55 \text{ V}$, -40 V
I_{DD}	1.2			mA typ	
	1.6		1.8	mA max	
I_{GND}	0.8			mA typ	
	1.0		1.1	mA max	
I_{SS}	0.5			mA typ	Digital inputs = 5 V
	1.0		1.8	mA max	$V_S = \pm 55 \text{ V}$, $V_D = 0 \text{ V}$
V_{DD}			8	V min	$\text{GND} = 0 \text{ V}$
			44	V max	$\text{GND} = 0 \text{ V}$

¹ Guaranteed by design. Not subject to production test.

CONTINUOUS CURRENT PER CHANNEL, S_{xx} OR D_x

Table 5.

Parameter	25°C	85°C	125°C	Unit	Test Conditions/Comments
16-Lead TSSOP $\theta_{JA} = 112.6^{\circ}\text{C/W}$	113	77	50	mA max	$V_S = V_{SS} + 4.5\text{ V to }V_{DD} - 4.5\text{ V}$
	88	61	42	mA max	$V_S = V_{SS} \text{ to } V_{DD}$
16-Lead LFCSP $\theta_{JA} = 30.4^{\circ}\text{C/W}$	207	125	68	mA max	$V_S = V_{SS} + 4.5\text{ V to }V_{DD} - 4.5\text{ V}$
	161	103	61	mA max	$V_S = V_{SS} \text{ to } V_{DD}$

ABSOLUTE MAXIMUM RATINGS

$T_A = 25^\circ\text{C}$, unless otherwise noted.

Table 6.

Parameter	Rating
V_{DD} to V_{SS}	48 V
V_{DD} to GND	-0.3 V to +48 V
V_{SS} to GND	-48 V to +0.3 V
Sxx to GND	-55 V to +55 V
Sxx to V_{DD} or V_{SS}	80 V
V_S to V_D	80 V
Dx Pin ¹ to GND	$V_{SS} - 0.7\text{ V}$ to $V_{DD} + 0.7\text{ V}$ or 30 mA, whichever occurs first
Digital Inputs to GND	GND - 0.7 V to 48 V or 30 mA, whichever occurs first
Peak Current, Sxx or Dx Pins	288 mA (pulsed at 1 ms, 10% duty cycle maximum)
Continuous Current, Sxx or Dx Digital Output	Data ² + 15% GND - 0.7 V to 6 V or 30 mA, whichever occurs first
Dx Pin, Overvoltage State, DR = GND, Load Current	1 mA
Operating Temperature Range	-40°C to +125°C
Storage Temperature Range	-65°C to +150°C
Junction Temperature	150°C
Thermal Impedance, θ_{JA}	
16-Lead TSSOP (4-Layer Board)	112.6°C/W
16-Lead LFCSP (4-Layer Board)	30.4°C/W
Reflow Soldering Peak Temperature, Pb-Free	As per JEDEC J-STD-020
ESD Rating, HBM: ESDA/JEDEC JS-001-2011	
Input/Output (I/O) Port to Supplies	6 kV
I/O Port to I/O Port	6 kV
All Other Pins	6 kV

¹ Overvoltages at the Dx pin are clamped by internal diodes. Limit current to the maximum ratings given.

² See Table 5.

Stresses at or above those listed under Absolute Maximum Ratings may cause permanent damage to the product. This is a stress rating only; functional operation of the product at these or any other conditions above those indicated in the operational section of this specification is not implied. Operation beyond the maximum operating conditions for extended periods may affect product reliability.

Only one absolute maximum rating can be applied at any one time.

ESD CAUTION



ESD (electrostatic discharge) sensitive device. Charged devices and circuit boards can discharge without detection. Although this product features patented or proprietary protection circuitry, damage may occur on devices subjected to high energy ESD. Therefore, proper ESD precautions should be taken to avoid performance degradation or loss of functionality.

PIN CONFIGURATIONS AND FUNCTION DESCRIPTIONS

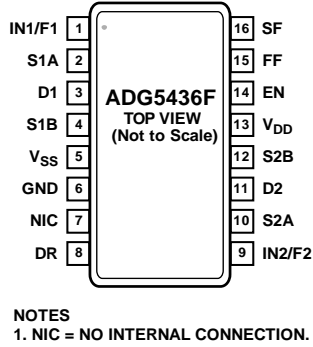

Figure 2. TSSOP Pin Configuration

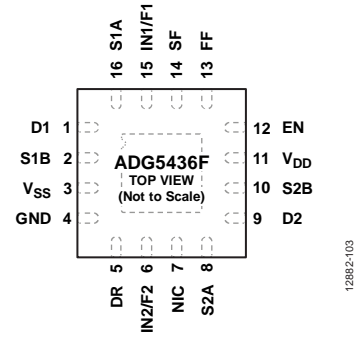

Figure 3. LFCSP Pin Configuration

Table 7. Pin Function Descriptions

Pin No.		Mnemonic	Description
TSSOP	LFCSP		
1	15	IN1/F1	Logic Control Input 1 (IN1). See Table 8. Decoder Pin (F1). This pin is used together with the specific fault pin (SF) to indicate which input is in a fault condition. See Table 9.
2	16	S1A	Overvoltage Protected Source Terminal 1A. This pin can be an input or output.
3	1	D1	Drain Terminal 1. This pin can be an input or output.
4	2	S1B	Overvoltage Protected Source Terminal 1B. This pin can be an input or output.
5	3	V _{SS}	Most Negative Power Supply Potential.
6	4	GND	Ground (0 V) Reference.
7	7	NIC	No Internal Connection.
8	5	DR	Drain Response Digital Input. Tying this pin to GND enables the drain to pull to V _{DD} or V _{SS} during an overvoltage fault condition. The default condition of the drain is open-circuit when the pin is left floating or if it is tied to V _{DD} .
9	6	IN2/F2	Logic Control Input 2 (IN2). See Table 8. Decoder Pin (F2). This pin is used together with the specific fault pin (SF) to indicate which input is in a fault condition. See Table 9.
10	8	S2A	Overvoltage Protected Source Terminal 2A. This pin can be an input or output.
11	9	D2	Drain Terminal 2. This pin can be an input or output.
12	10	S2B	Overvoltage Protected Source Terminal 2B. This pin can be an input or output.
13	11	V _{DD}	Most Positive Power Supply Potential.
14	12	EN	Active High Digital Input. When this pin is low, the device is disabled and all switches are off. When this pin is high, the INx logic inputs determine the on switches.
15	13	FF	Fault Flag Digital Output. This pin has a high output when the device is in normal operation or a low output when a fault condition occurs on any of the Sxx inputs. The FF pin has a weak internal pull-up that allows the signals to be combined into a single interrupt for larger modules that contain multiple devices.
16	14	SF	Specific Fault Digital Output. This pin has a high output when the device is in normal operation, or a low output when a fault condition is detected on a specific pin, depending on the state of F1 and F2 per Table 9.
	EP	Exposed Pad	The exposed pad is connected internally. For increased reliability of the solder joints and maximum thermal capability, it is recommended that the pad be soldered to the lowest supply voltage, V _{SS} .

TRUTH TABLES FOR SWITCHES

Table 8. Truth Table

INx	SxA	SxB
0	Off	On
1	On	Off

Table 9. Fault Diagnostic Output Truth Table

Switch in Fault¹	State of Specific Fault Pin (SF) with Decoder Pins (F2, F1)				State of Fault Flag (FF)
	F2 = 0, F1 = 0	F2 = 0, F1 = 1	F2 = 1, F1 = 0	F2 = 1, F1 = 1	
None	1	1	1	1	1
S1A	0	1	1	1	0
S1B	1	0	1	1	0
S2A	1	1	1	0	0
S2B	1	1	0	1	0
S1A, S1B	0	0	1	1	0
S1A, S2A	0	1	1	0	0
S1A, S2B	0	1	0	1	0
S1B, S2A	1	0	1	0	0
S1B, S2B	1	0	0	1	0
S2A, S2B	1	1	0	0	0
S1A, S1B, S2A	0	0	1	0	0
S1A, S1B, S2B	0	0	0	1	0
S1A, S2A, S2B	0	1	0	0	0
S1B, S2A, S2B	1	0	0	0	0
S1A, S1B, S2A, S2B	0	0	0	0	0

¹ Note that more than one pin can be in fault at any one time. See the Applications Information section for more details.

TYPICAL PERFORMANCE CHARACTERISTICS

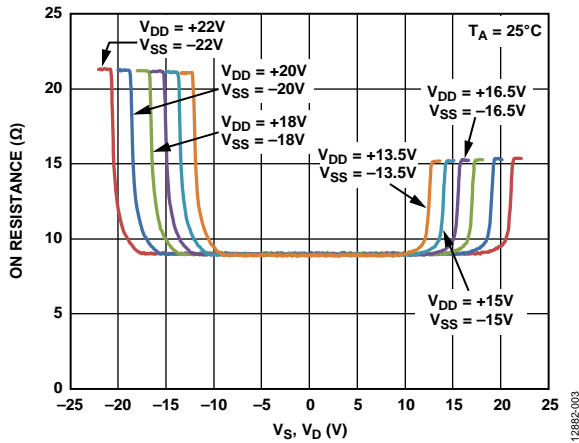

Figure 4. R_{ON} as a Function of V_S and V_D , Various Dual Supplies

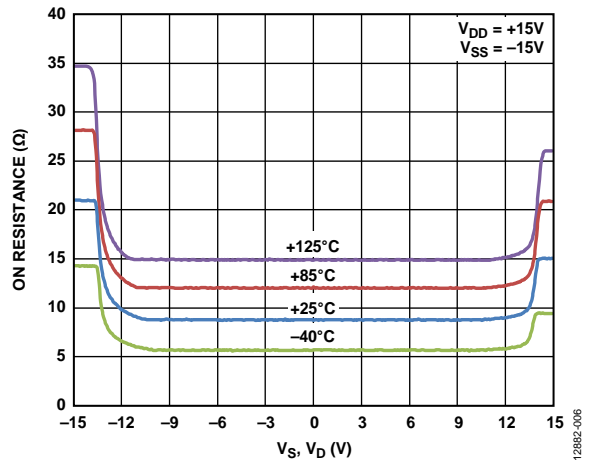

Figure 7. R_{ON} as a Function of V_S and V_D for Different Temperatures, ± 15 V Dual Supply

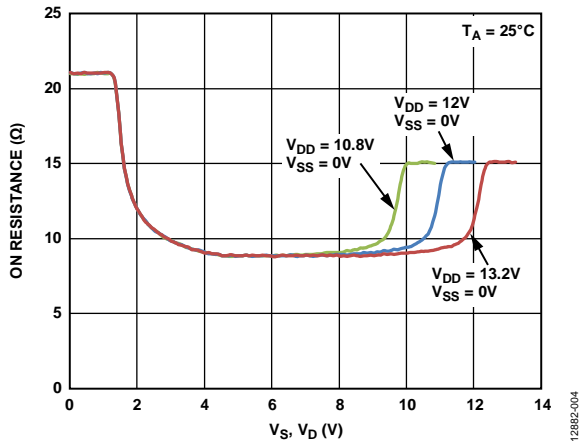

Figure 5. R_{ON} as a Function of V_S and V_D , 12 V Single Supply

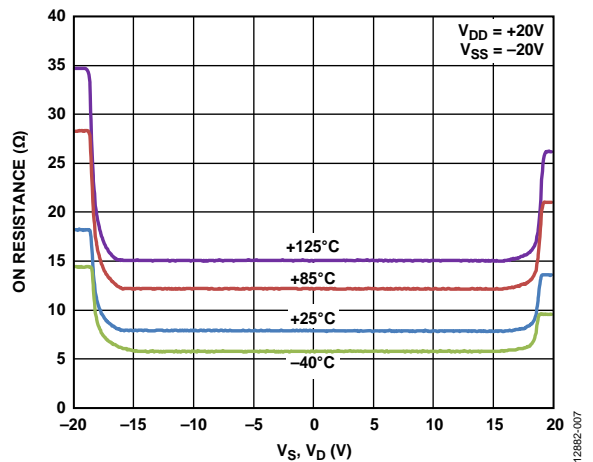

Figure 8. R_{ON} as a Function of V_S and V_D for Different Temperatures, ± 20 V Dual Supply

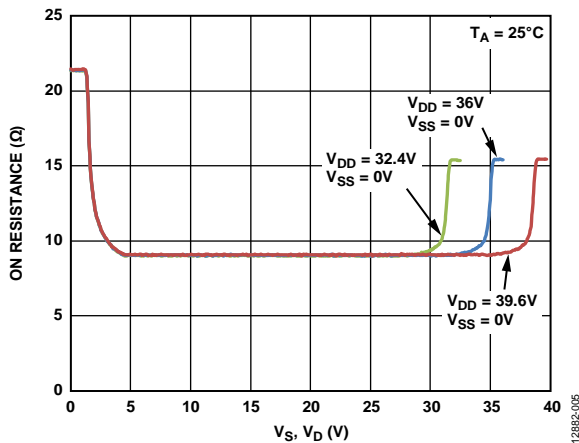

Figure 6. R_{ON} as a Function of V_S and V_D , 36 V Single Supply

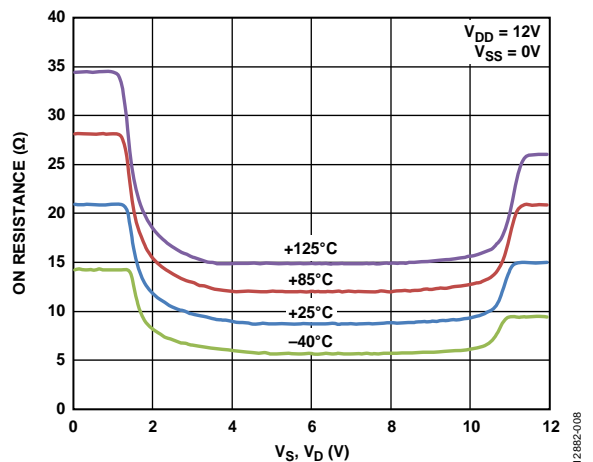

Figure 9. R_{ON} as a Function of V_S and V_D for Different Temperatures, 12 V Single Supply

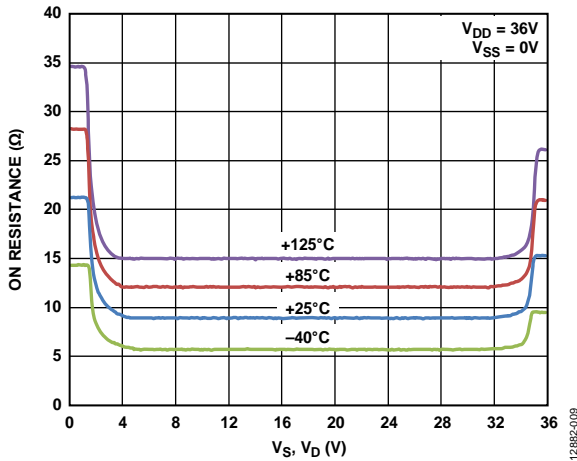

Figure 10. R_{ON} as a Function of V_S and V_D for Different Temperatures, 36 V Single Supply

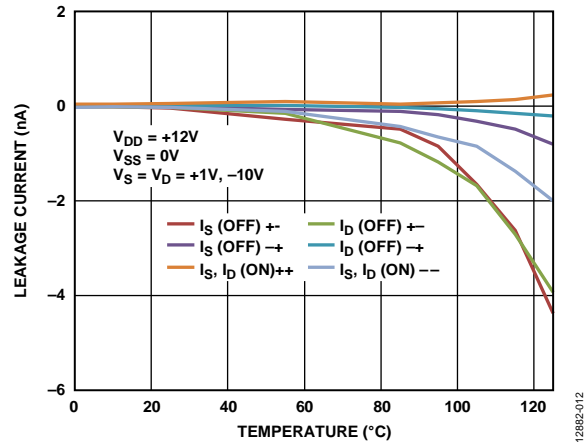

Figure 13. Leakage Current vs. Temperature, 12 V Single Supply

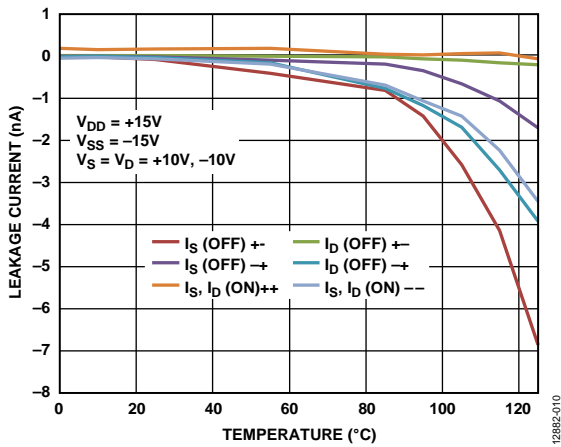

Figure 11. Leakage Current vs. Temperature, ±15 V Dual Supply

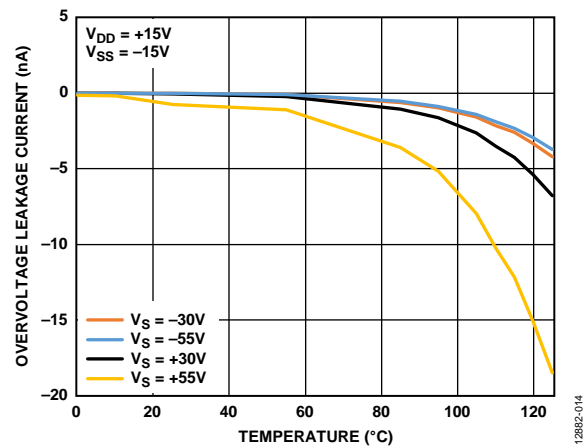

Figure 14. Overvoltage Leakage Current vs. Temperature, ±15 V Dual Supply

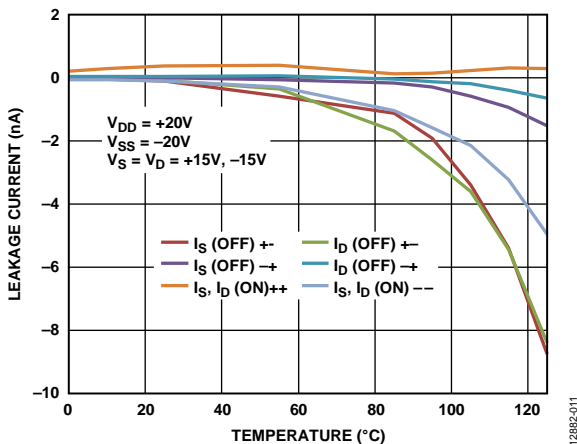

Figure 12. Leakage Current vs. Temperature, ±20 V Dual Supply

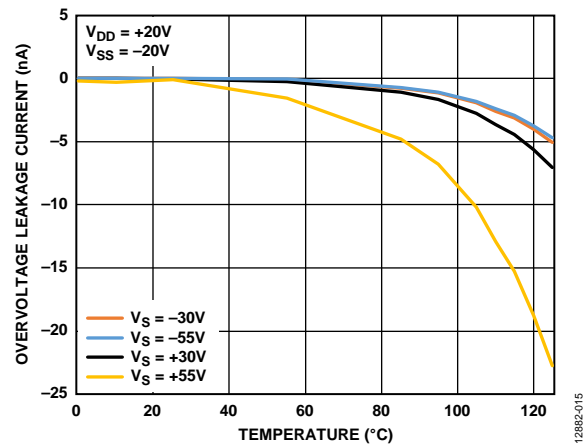

Figure 15. Overvoltage Leakage Current vs. Temperature, ±20 V Dual Supply

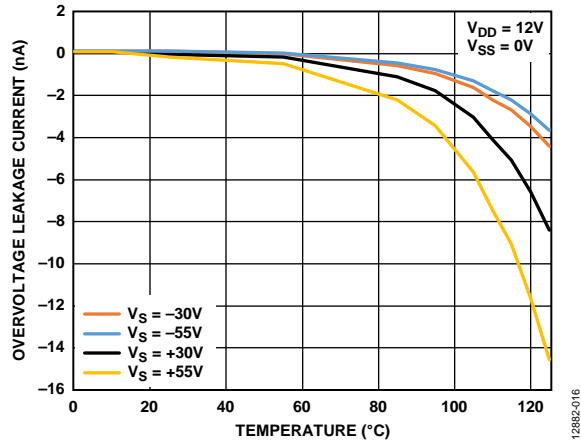

Figure 16. Overvoltage Leakage Current vs. Temperature, 12 V Single Supply

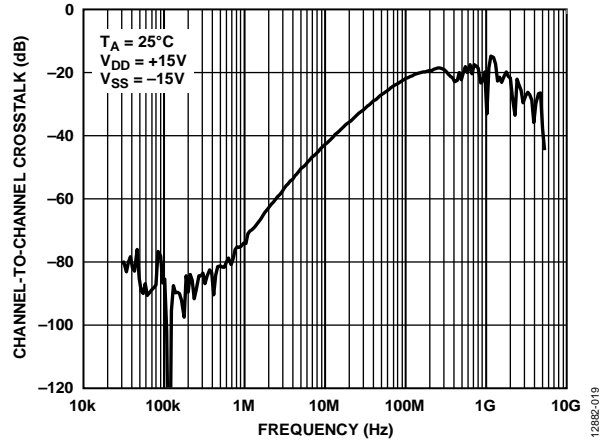

Figure 19. Channel-to-Channel Crosstalk vs. Frequency

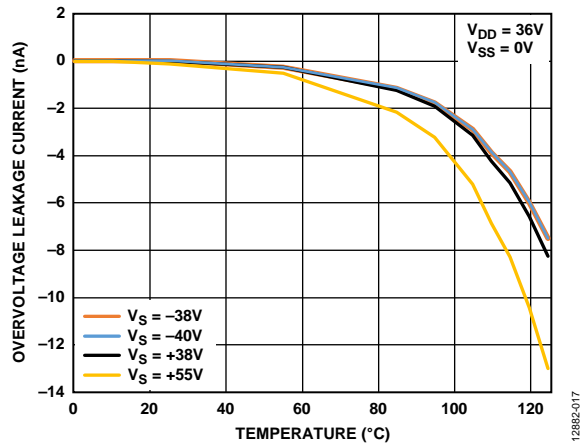

Figure 17. Overvoltage Leakage Current vs. Temperature, 36 V Single Supply

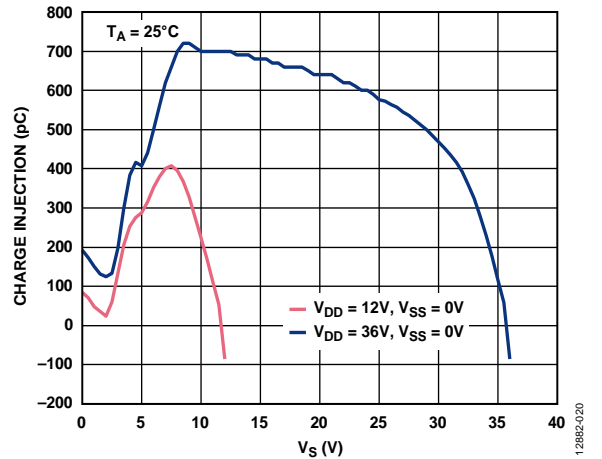

Figure 20. Charge Injection vs. Source Pin Voltage (V_S), Single Supply

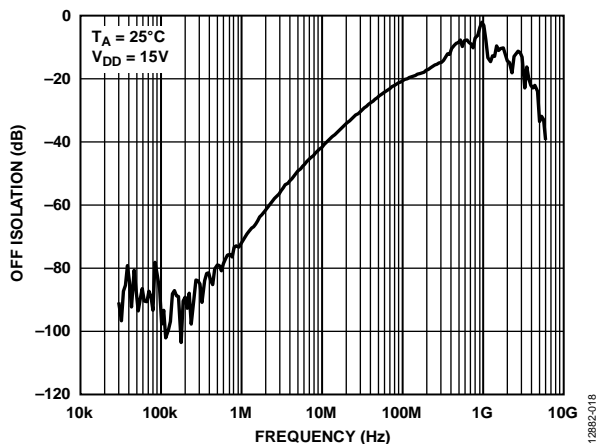

Figure 18. Off Isolation vs. Frequency

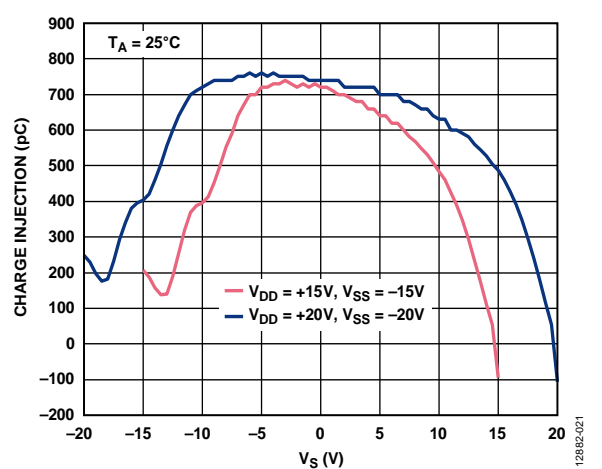

Figure 21. Charge Injection vs. Source Pin Voltage (V_S), Dual Supply

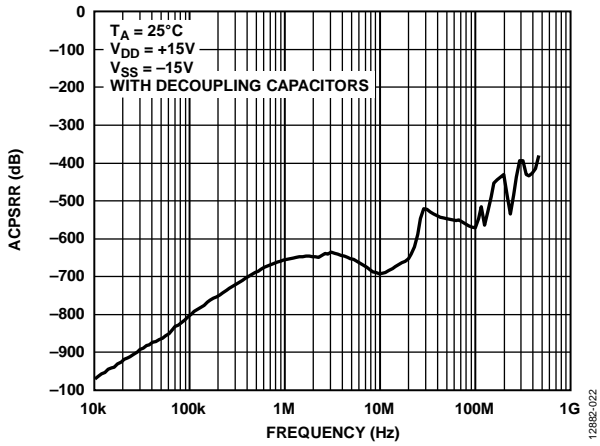

Figure 22. ACPSRR vs. Frequency

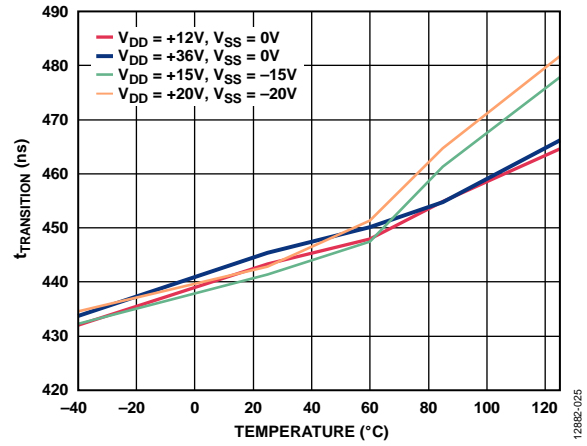

Figure 25. $t_{\text{TRANSITION}}$ vs. Temperature

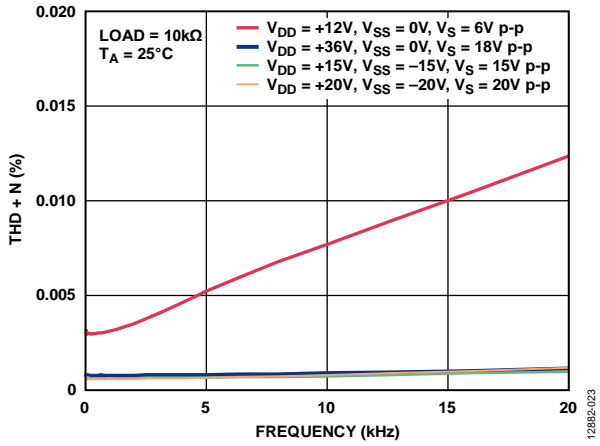

Figure 23. THD + N vs. Frequency

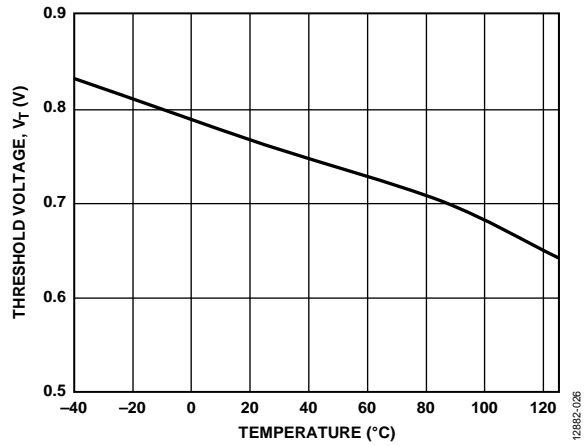

Figure 26. Threshold Voltage (V_T) vs. Temperature

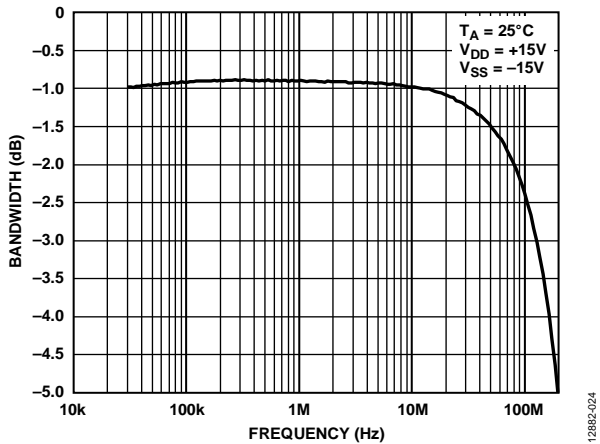

Figure 24. Bandwidth vs. Frequency

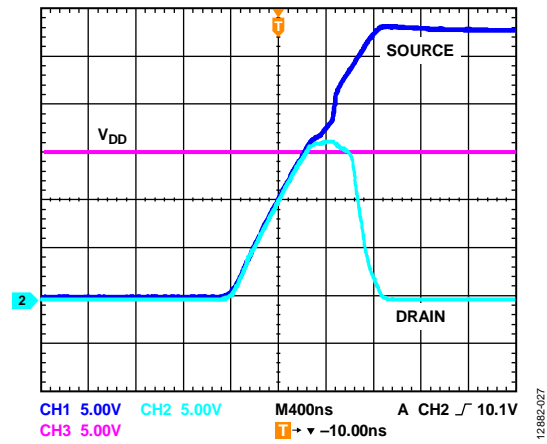

Figure 27. Drain Output Response to Positive Overvoltage (DR Pin = Floating or High)

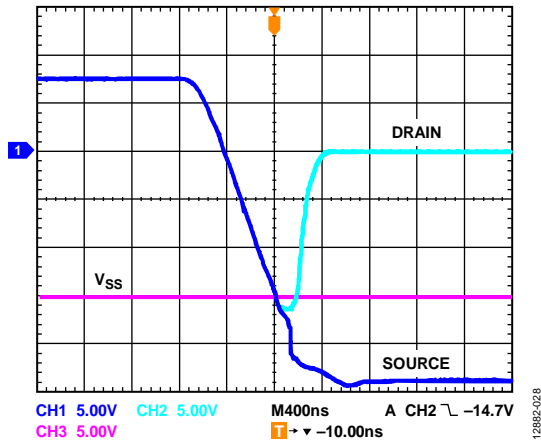

Figure 28. Drain Output Response to Negative Overvoltage (DR Pin = Floating or High)

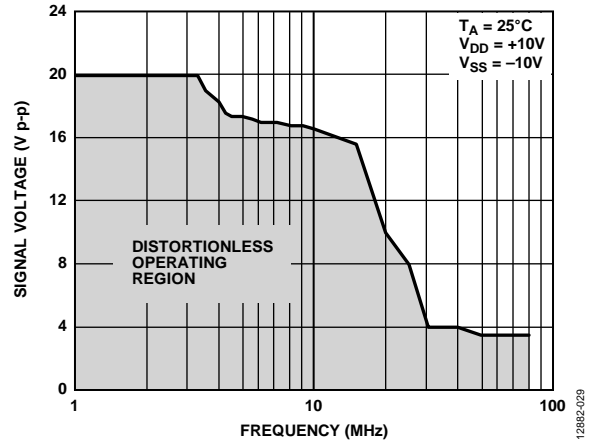

Figure 29. Large Signal Voltage Tracking vs. Frequency

TEST CIRCUITS

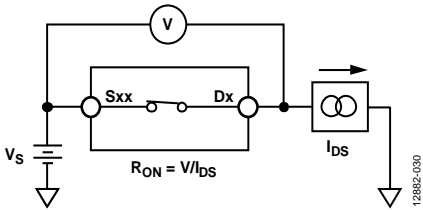

Figure 30. On Resistance

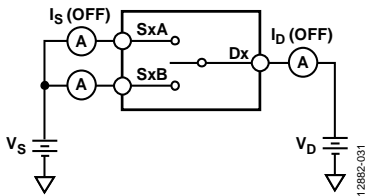

Figure 31. Off Leakage

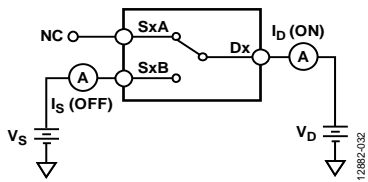

Figure 32. Channel On Leakage

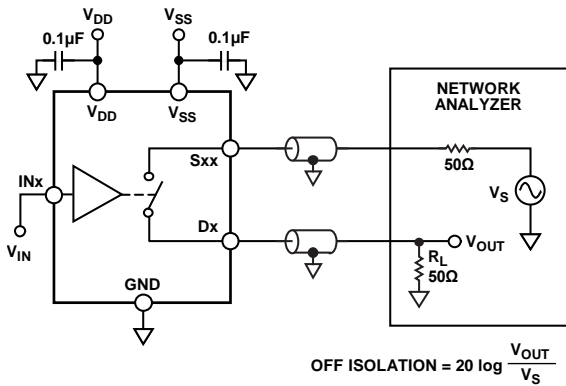

Figure 33. Off Isolation

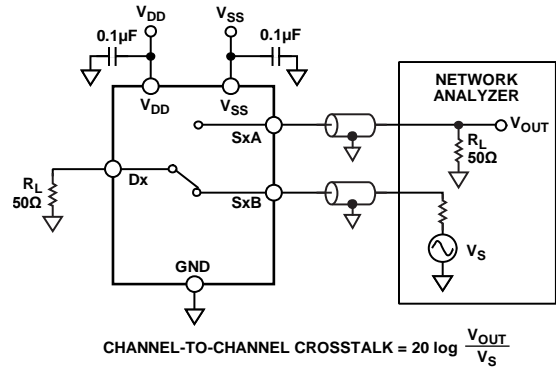

Figure 34. Channel-to-Channel Crosstalk

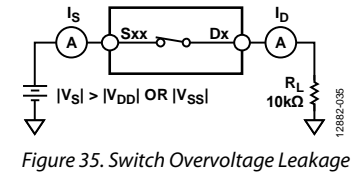

Figure 35. Switch Overvoltage Leakage

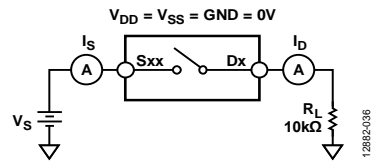

Figure 36. Switch Unpowered Leakage

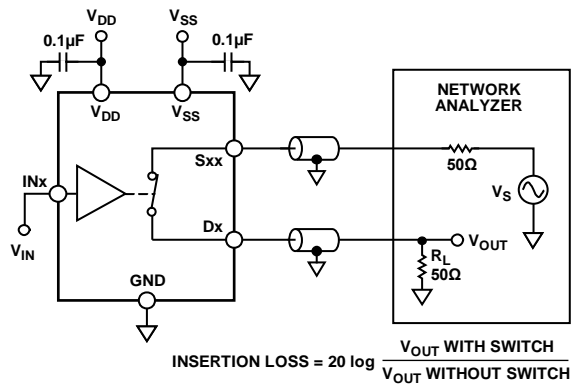

Figure 37. Bandwidth

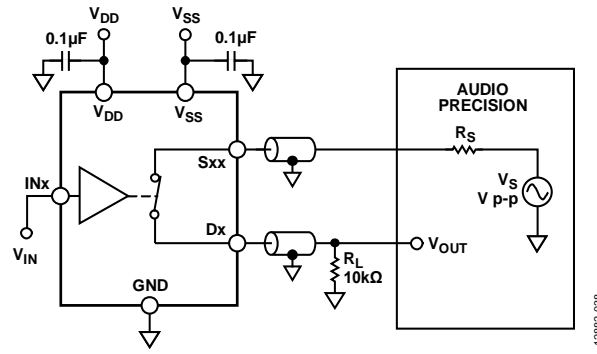
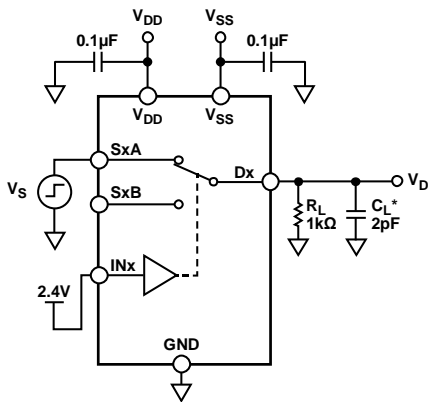

Figure 38. THD + N



*INCLUDES TRACK CAPACITANCE

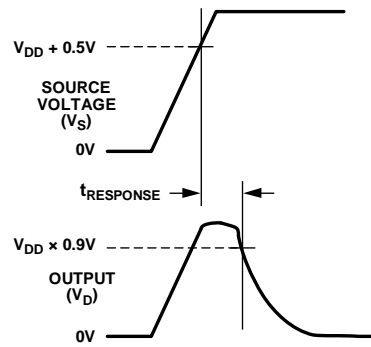
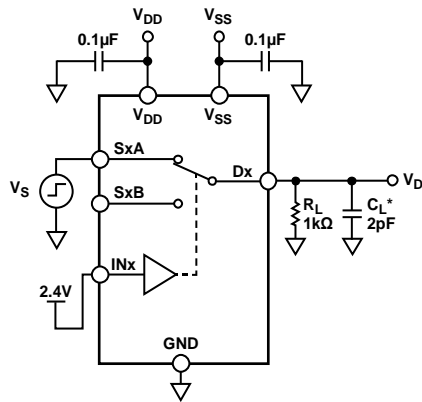

Figure 39. Overvoltage Response Time, $t_{RESPONSE}$



*INCLUDES TRACK CAPACITANCE

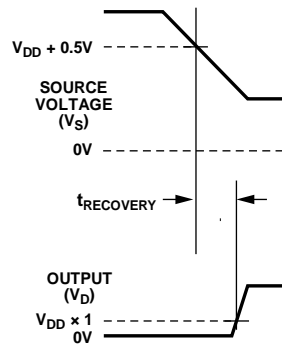

Figure 40. Overvoltage Recovery Time, $t_{RECOVERY}$

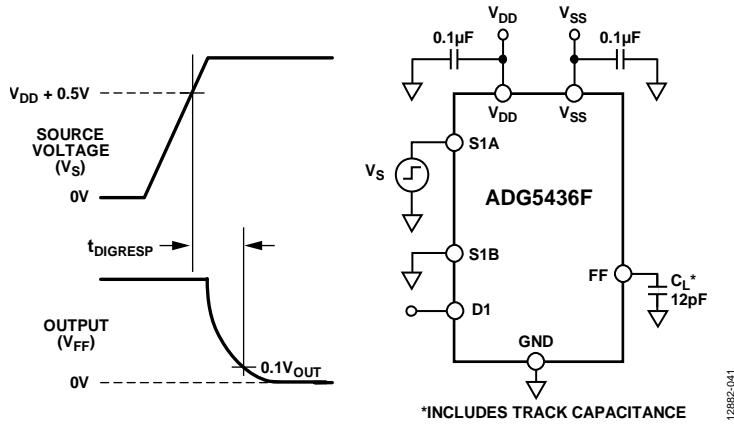

Figure 41. Interrupt Flag Response Time, $t_{DIGRESP}$

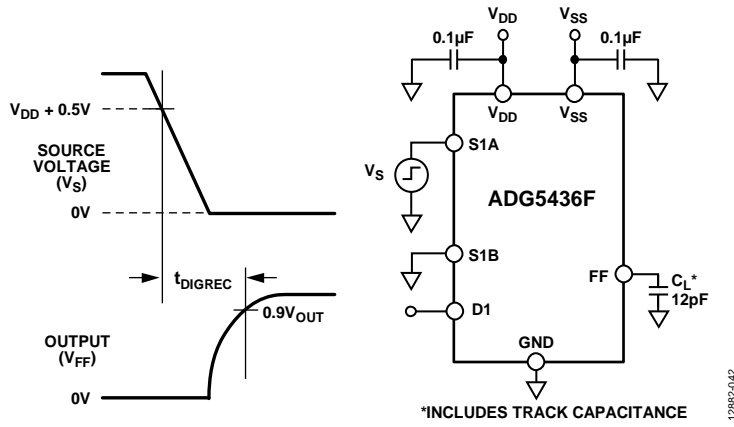

Figure 42. Interrupt Flag Recovery Time, t_{DIGREC}

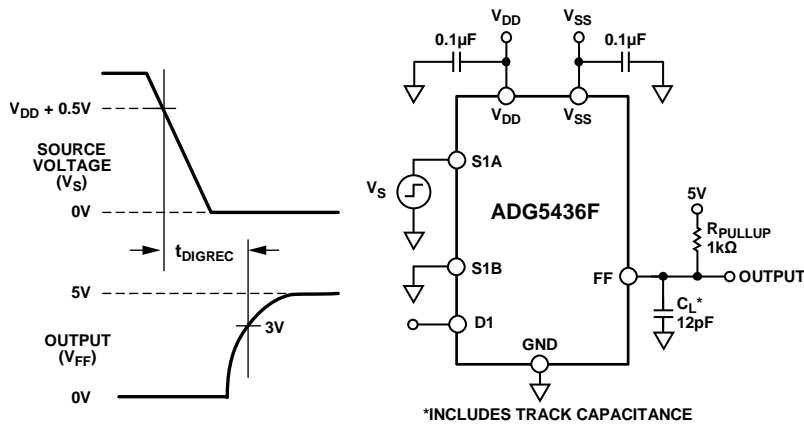

Figure 43. Interrupt Flag Recovery Time, t_{DIGREC} , with a 1 kΩ Pull-Up Resistor

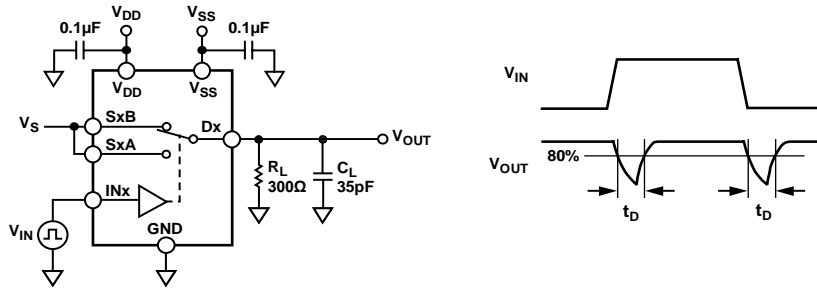

Figure 44. Break-Before-Make Time Delay, t_D

12882-044

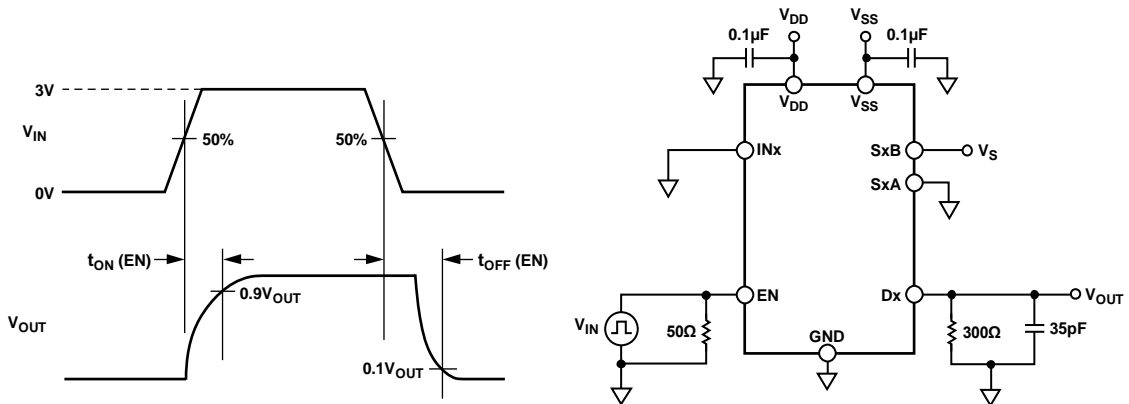

Figure 45. Enable Delay, $t_{ON} (EN)$, $t_{OFF} (EN)$

12882-045

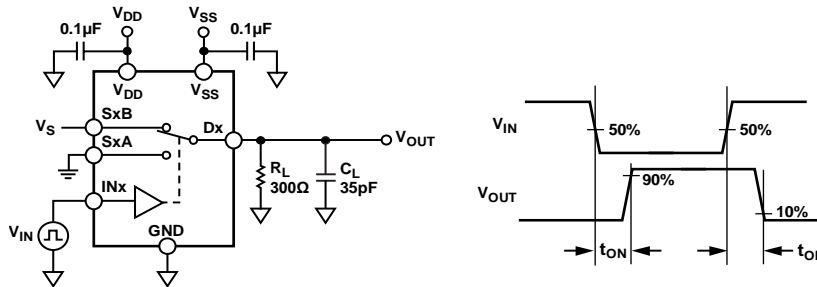

Figure 46. Address to Output Switching Times, $t_{TRANSITION}$

12882-046

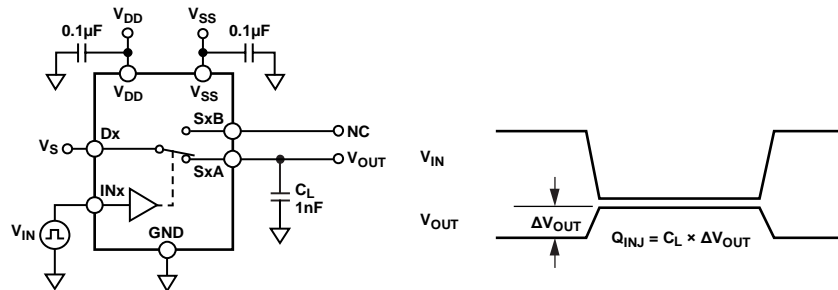

Figure 47. Charge Injection, Q_{INJ}

12882-047

TERMINOLOGY

I_{DD}

I_{DD} represents the positive supply current.

I_{SS}

I_{SS} represents the negative supply current.

V_D, V_S

V_D and V_S represent the analog voltage on the Dx pins and the Sxx pins, respectively.

R_{ON}

R_{ON} represents the ohmic resistance between the Dx pins and the Sxx pins.

ΔR_{ON}

ΔR_{ON} represents the difference between the R_{ON} of any two channels.

$R_{FLAT(ON)}$

$R_{FLAT(ON)}$ is the flatness defined as the difference between the maximum and minimum value of on resistance measured over the specified analog signal range.

I_S (Off)

I_S (Off) is the source leakage current with the switch off.

I_D (Off)

I_D (Off) is the drain leakage current with the switch off.

I_D (On), I_S (On)

I_D (On) and I_S (On) represent the channel leakage currents with the switch on.

V_{INL}

V_{INL} is the maximum input voltage for Logic 0.

V_{INH}

V_{INH} is the minimum input voltage for Logic 1.

I_{INL}, I_{INH}

I_{INL} and I_{INH} represent the low and high input currents of the digital inputs.

C_D (Off)

C_D (Off) represents the off switch drain capacitance, which is measured with reference to ground.

C_S (Off)

C_S (Off) represents the off switch source capacitance, which is measured with reference to ground.

C_D (On), C_S (On)

C_D (On) and C_S (On) represent on switch capacitances, which are measured with reference to ground.

C_{IN}

C_{IN} is the digital input capacitance.

t_{ON}

t_{ON} represents the delay between applying the digital control input and the output switching on (see Figure 45).

t_{OFF}

t_{OFF} represents the delay between applying the digital control input and the output switching off (see Figure 45).

t_D

t_D represents the off time measured between the 90% point of both switches when switching from one address state to another.

$t_{DIGRESP}$

$t_{DIGRESP}$ is the time required for the FF pin to go low (0.3 V), measured with respect to the voltage on the source pin exceeding the supply voltage by 0.5 V.

t_{DIGREC}

t_{DIGREC} is the time required for the FF pin to return high, measured with respect to the voltage on the Sxx pin falling below the supply voltage plus 0.5 V.

$t_{RESPONSE}$

$t_{RESPONSE}$ represents the delay between the source voltage exceeding the supply voltage by 0.5 V and the drain voltage falling to 90% of the supply voltage.

$t_{RECOVERY}$

$t_{RECOVERY}$ represents the delay between an overvoltage on the Sxx pin falling below the supply voltage plus 0.5 V and the drain voltage rising from 0 V to 10% of the supply voltage.

Off Isolation

Off isolation is a measure of unwanted signal coupling through an off switch.

Charge Injection

Charge injection is a measure of the glitch impulse transferred from the digital input to the analog output during switching.

Channel-to-Channel Crosstalk

Channel-to-channel crosstalk is a measure of unwanted signal that is coupled through from one channel to another as a result of parasitic capacitance.

–3 dB Bandwidth

–3 dB bandwidth is the frequency at which the output is attenuated by 3 dB.

On Response

On response is the frequency response of the on switch.

Insertion Loss

Insertion loss is the loss due to the on resistance of the switch.

Total Harmonic Distortion Plus Noise (THD + N)

THD + N is the ratio of the harmonic amplitude plus noise of the signal to the fundamental.

AC Power Supply Rejection Ratio (ACPSRR)

ACPSRR is the ratio of the amplitude of the signal on the output to the amplitude of the modulation. ACPSRR is a measure of the ability of the device to avoid coupling noise and spurious signals that appear on the supply voltage pin to the output of the switch. The dc voltage on the device is modulated by a sine wave of 0.62 V p-p.

 V_T

V_T is the voltage threshold at which the overvoltage protection circuitry engages (see Figure 26).

THEORY OF OPERATION

SWITCH ARCHITECTURE

Each channel of the ADG5436F consists of a parallel pair of NDMOS and PDMOS transistors. This construction provides excellent performance across the signal range. The ADG5436F channels operate as standard switches when input signals with a voltage between V_{SS} and V_{DD} are applied. For example, the on resistance is $10\ \Omega$ typically and the appropriate control pin, IN_x , controls the opening or closing of the switch.

Additional internal circuitry enables the switch to detect overvoltage inputs by comparing the voltage on the source pin with V_{DD} and V_{SS} . A signal is considered overvoltage if it exceeds the supply voltages by the voltage threshold, V_T . The threshold voltage is typically $0.7\ V$, but can range from $0.8\ V$ at -40°C down to $0.6\ V$ at $+125^\circ\text{C}$. See Figure 26 to see the change in V_T with operating temperature.

The maximum voltage that can be applied to any source input is $-55\ V$ or $+55\ V$. When the device is powered using a single supply of greater than $25\ V$, the maximum undervoltage signal level reduces down from $-55\ V$. For example, the undervoltage signal reduces to $-40\ V$ at $V_{DD} = 40\ V$ to remain within the $80\ V$ maximum rating. The construction of the process allows the channel to withstand $80\ V$ across the switch when it is opened. These overvoltage limits apply whether the power supplies are present or not.

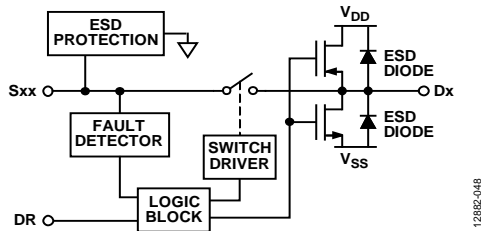

Figure 48. Switch Channel and Control Function

When an overvoltage condition is detected on a source pin (S_{xx}), the switch automatically opens and the source pin (S_{xx}) becomes high impedance and ensures that no current flows through the switch. If the DR pin is driven low, the drain pin, D_x , is pulled to the supply that was exceeded. For example, if the source voltage exceeds V_{DD} , the drain output pulls to V_{DD} . The same is true for V_{SS} . If the DR pin is allowed to float or is driven high, the D_x pin also becomes open circuit. The voltage on the D_x pin follows the voltage on the source pin, S_{xx} , until the switch turns off completely and the drain voltage discharges through the load. The maximum voltage on the drain is limited by the internal ESD diodes and the rate at which the output voltage discharges is dependent on the load at the pin.

During overvoltage conditions, the leakage current into and out of the source pins (S_{xx}) is limited to tens of microamperes. If the DR pin is allowed to float or is driven high, only nanoamperes of leakage are seen on the drain pin (D_x). If the DR pin is driven low, the drain pin (D_x) is pulled to the rail. The device that pulls the drain pin to the rail has an impedance of approximately $40\ k\Omega$; therefore, the D_x pin current is limited to about $1\ \text{mA}$ during a shorted load condition. This internal impedance also determines the minimum external load resistance required to ensure that the drain pin is pulled to the desired voltage level during a fault.

When an overvoltage event occurs, the channels undisturbed by the overvoltage input continue to operate normally without additional crosstalk.

ESD Performance

The ADG5436F has an ESD (HBM) rating of $6\ \text{kV}$.

The drain pins (D_x) have ESD protection diodes to the supply rails, and the voltage at these pins must not exceed the supply voltage.

The source pins (S_{xx}) have specialized ESD protection that allows the signal voltage to reach $\pm 55\ V$ with a $\pm 22\ V$ dual supply, and from $-40\ V$ to $+55\ V$ with a $+40\ V$ single supply. See Figure 48 for the switch channel overview. Exceeding $\pm 55\ V$ on any source input may damage the ESD protection circuitry on the device.

Trench Isolation

In the ADG5436F, an insulating oxide layer (trench) is placed between the NDMOS and the PDMOS transistors of each switch. Parasitic junctions, which occur between the transistors in junction isolated switches, are eliminated, and the result is a switch that is latch-up immune under all circumstances. This device passes a JESD78D latch-up test of $\pm 500\ \text{mA}$ for $1\ \text{sec}$, the strictest test in the specification.

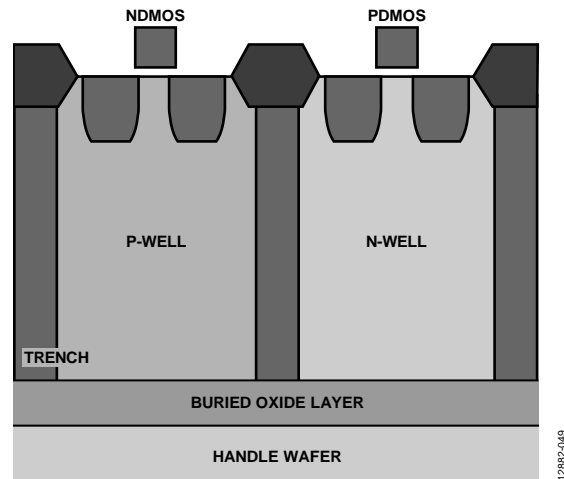

Figure 49. Trench Isolation

FAULT PROTECTION

When the voltages at the source inputs exceed V_{DD} or V_{SS} by V_T , the switch turns off, or, if the device is unpowered, the switch remains off. The switch input remains high impedance regardless of the digital input state or the load resistance, and the output acts as a virtual open circuit. Signal levels up to +55 V and -55 V are blocked in both the powered and unpowered conditions as long as the 80 V limitation between the source and supply pins is met.

Power-On Protection

The following three conditions must be satisfied for the switch to be in the on condition:

- V_{DD} to $V_{SS} \geq 8$ V.
- The input signal is between $V_{SS} - V_T$ and $V_{DD} + V_T$.
- The digital logic control input, IN_x , is turned on.

When the switch is turned on, the signal levels up to the supply rails are passed.

The switch responds to an analog input that exceeds V_{DD} or V_{SS} by a threshold voltage, V_T , by turning off. The absolute input voltage limits are -55 V and +55 V, while maintaining an 80 V limit between the source pin and the supply rails. The switch remains off until the voltage at the source pin returns to between V_{DD} and V_{SS} .

The fault response time ($t_{RESPONSE}$) when powered by a ± 15 V dual supply is typically 510 ns, and the fault recovery time ($t_{RECOVERY}$) is 820 ns. These vary with supply voltages and output load conditions.

Exceeding ± 55 V on any source input may damage the ESD protection circuitry on the device.

The maximum stress across the switch channel is 80 V.

Therefore, the user must pay close attention to this limit when using the device with a 40 V single supply. In this case, the maximum undervoltage condition is -40 V to maintain the 80 V across the switch channel.

For undervoltage and overvoltage conditions, consider the case where the device is set up as shown in Figure 50.

- $V_{DD}/V_{SS} = \pm 22$ V.
- S1A and S2A = 22 V, and are both on. Therefore, D1 and D2 = 22 V.
- S1B has a -55 V fault and S2B has a +55 V fault.
- The voltage between S1B and D1 = $22\text{ V} - (-55\text{ V}) = +77\text{ V}$.
- The voltage between S2B and D2 = $22\text{ V} - 55\text{ V} = -33\text{ V}$.

These calculations are all within device specifications: a 55 V maximum fault on source inputs and a maximum of 80 V across the off switch channel.

FF is low due to the fault conditions. The specific switches in fault can be deduced by cycling through F2 and F1 and noting the state of SF. In this example, SF is low (asserted) when F2 = 0 and F1 = 1; it is also low when F2 = 1 and F1 = 0. This signifies a fault on S1B and S2B. See Table 9 for details on how to decode SF by F2 and F1.

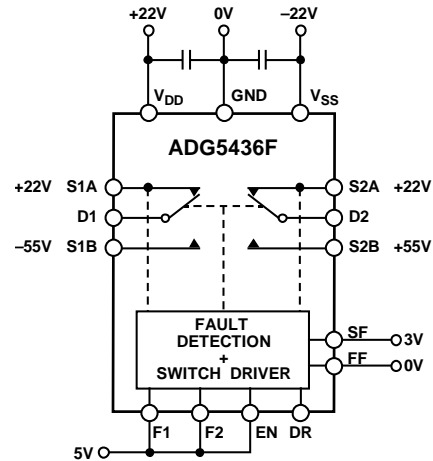

Figure 50. ADG5436F Under Example Overvoltage Conditions

Power-Off Protection

When no power supplies are present, the switch remains in the off condition, and the switch inputs are high impedance. This state ensures that no current flows and prevents damage to the switch or downstream circuitry. The switch output is a virtual open circuit.

The switch remains off regardless of whether the V_{DD} and V_{SS} supplies are 0 V or floating. A GND reference must always be present to ensure proper operation. Signal levels of up to ± 55 V are blocked in the unpowered condition.

Digital Input Protection

The ADG5436F can tolerate unpowered digital input signals present on the device. When the device is unpowered, the switch is guaranteed to be in the off state, regardless of the state of the digital logic signals.

The digital inputs are protected against positive faults up to 44 V. The digital inputs do not offer protection against negative overvoltages. ESD protection diodes connected to GND are present on the digital inputs.

Overvoltage Interrupt Flag

The voltages on the source inputs of the ADG5436F are continuously monitored, and the state of the switches is indicated by an active low digital output pin, FF.

The voltage on the FF pin indicates if any of the source input pins are experiencing a fault condition. The output of the FF pin is a nominal 3 V when all source pins are within normal operating range. If any source pin voltage exceeds the supply voltage by V_T , the FF output reduces to below 0.8 V.

Use the specific fault digital output pin, SF, to decode which inputs are experiencing a fault condition. The SF pin reduces to below 0.8 V when a fault condition is detected on a specific pin, depending on the state of F1 and F2 (see Table 9). The specific fault feature also works with the switches disabled (EN pin low), which allows the user to cycle through and check the fault conditions without connecting the fault to the drain output.

APPLICATIONS INFORMATION

The overvoltage protected family of switches and multiplexers provide a robust solution for instrumentation, industrial, aerospace, and other harsh environments where overvoltage signals can be present and the system must remain operational both during and after the overvoltage has occurred.

POWER SUPPLY RAILS

To guarantee correct operation of the device, 0.1 μF decoupling capacitors are required.

The ADG5436F can operate with bipolar supplies between $\pm 5\text{ V}$ and $\pm 22\text{ V}$. The supplies on V_{DD} and V_{SS} do not need to be symmetrical, but the V_{DD} to V_{SS} range must not exceed 44 V. The ADG5436F can also operate with single supplies between 8 V and 44 V, with V_{SS} connected to GND.

The ADG5436F is fully specified at the $\pm 15\text{ V}$, $\pm 20\text{ V}$, 12 V, and +36 V supply ranges.

POWER SUPPLY SEQUENCING PROTECTION

The switch channel remains open when the device is unpowered and signals from -55 V to $+55\text{ V}$ can be applied without damaging the device. The switch channel closes only when the supplies are connected, a suitable digital control signal is placed on the IN_x pins, and the signal is within the normal operating range. Placing the ADG5436F between external connectors and sensitive components offers protection in systems where a signal is presented to the source pins before the supply voltages are available.

SIGNAL RANGE

The ADG5436F has overvoltage detection circuitry on the inputs that compares the voltage levels at the source terminals with V_{DD} and V_{SS} . To protect downstream circuitry from overvoltage conditions, supply the ADG5436F with voltages that match the intended signal range. The low on-resistance switch allows signals to the supply rails to be passed with very little distortion. A signal that exceeds the supply rail by the threshold voltage is then blocked. This signal block offers protection to both the device and any downstream circuitry.

LOW IMPEDANCE CHANNEL PROTECTION

The ADG5436F can be used as a protective element in signal chains that are sensitive to both channel impedance and overvoltage signals. Traditionally, series resistors limit the current during an overvoltage condition to protect susceptible components.

These series resistors affect the performance of the signal chain and reduce the signal chain precision. A compromise must be reached on the value of the series resistance that is high enough to sufficiently protect sensitive components, but low enough that the precision performance of the signal chain is not sacrificed.

The ADG5436F enables the designer to remove these resistors and retain precision performance without compromising the protection of the circuit.

POWER SUPPLY RECOMMENDATIONS

Analog Devices, Inc., has a wide range of power management products to meet the requirements of most high performance signal chains.

An example of a bipolar power solution is shown in Figure 51. The ADP7118 and ADP7182 can be used to generate clean positive and negative rails from the dual switching regulator output. These rails can be used to power the ADG5436F, amplifier, and/or precision converter in a typical signal chain.

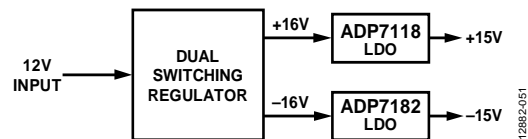

Figure 51. Bipolar Power Solution

Table 10. Recommended Power Management Devices

Product	Description
ADP7118	20 V, 200 mA, low noise, CMOS LDO
ADP7142	40 V, 200 mA, low noise, CMOS LDO
ADP7182	-28 V, -200 mA, low noise, linear regulator

HIGH VOLTAGE SURGE SUPPRESSION

The ADG5436F is not intended for use in very high voltage applications. The maximum operating voltage of the transistor is 80 V. In applications where the inputs are likely to be subject to overvoltage conditions exceeding the breakdown voltage, use transient voltage suppressors (TVSs) or similar devices.

INTELLIGENT FAULT DETECTION

The [ADG5436F](#) digital output pin, FF, can interface with a microprocessor or control system and can be used as an interrupt flag. This feature provides real-time diagnostic information on the state of the device and the system to which it connects.

The control system can use the digital interrupt, FF, to start a variety of actions, as follows:

- Initiating an investigation into the source of an overvoltage fault.
- Shutting down critical systems in response to the overvoltage condition.
- Using data recorders to mark data during these events as unreliable or out of specification.

For systems sensitive during a start-up sequence, the active low operation of the flag allows the system to ensure that the [ADG5436F](#) is powered on and that all input voltages are within the normal operating range before initiating operation.

The FF pin is a weak pull-up, which allows the signals to combine into a single interrupt for larger modules that contain multiple devices.

The recovery time, t_{DIGREC} , can be decreased from a typical 60 μ s to 600 ns by using a 1 k Ω pull-up resistor.

The specific fault digital output, SF decodes which inputs are experiencing a fault condition. The SF pin reduces to below 0.8 V when a fault condition is detected on a specific pin, depending on the state of F1 and F2 (see Table 9). The specific fault feature also works with the switches disabled (EN pin low), which allows the user to cycle through and check the fault conditions without connecting the fault to the drain output.

LARGE VOLTAGE, HIGH FREQUENCY SIGNALS

Figure 29 shows the voltage range and frequencies that the [ADG5436F](#) can reliably convey. For signals extending across the full signal range from V_{SS} to V_{DD} , keep the frequency below 3 MHz. If the required frequency is greater than 3 MHz, decrease the signal range appropriately to ensure signal integrity.

OUTLINE DIMENSIONS

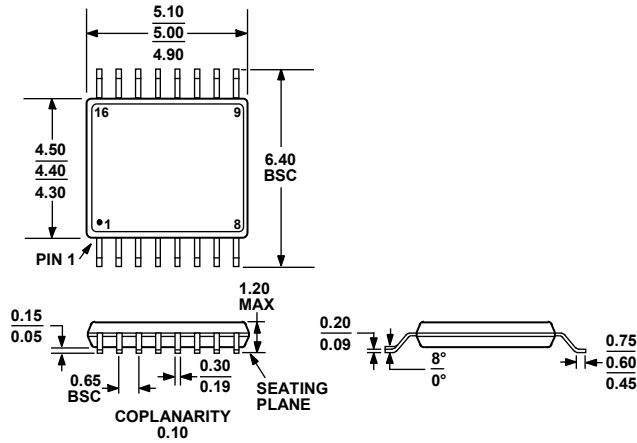

COMPLIANT TO JEDEC STANDARDS MO-153-AB

Figure 52. 16-Lead Thin Shrink Small Outline Package [TSSOP] (RU-16)

Dimensions shown in millimeters

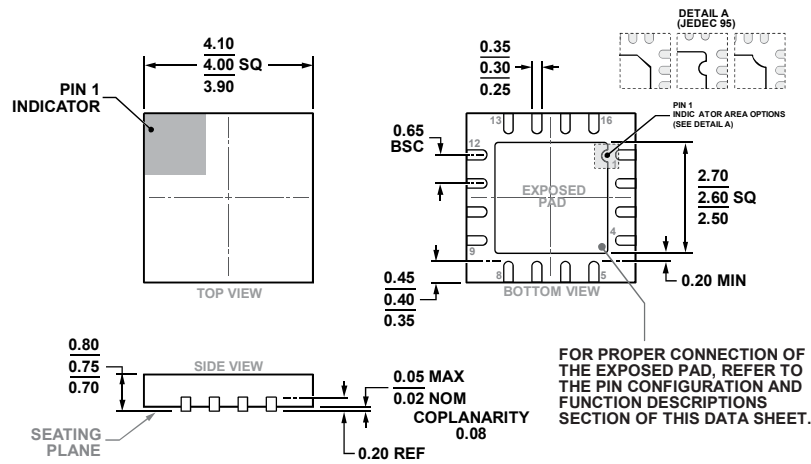

COMPLIANT TO JEDEC STANDARDS MO-220-WGGC.

Figure 53. 16-Lead Lead Frame Chip Scale Package [LFCSP] 4 mm x 4 mm Body and 0.75 mm Package Height (CP-16-17)

Dimensions shown in millimeters

ORDERING GUIDE

Model ¹	Temperature Range	Package Description	Package Option
ADG5436FBRUZ	-40°C to +125°C	16-Lead Thin Shrink Small Outline Package [TSSOP]	RU-16
ADG5436FBRUZ-RL7	-40°C to +125°C	16-Lead Thin Shrink Small Outline Package [TSSOP]	RU-16
ADG5436FBCPZ-RL7	-40°C to +125°C	16-Lead Lead Frame Chip Scale Package [LFCSP]	CP-16-17

¹ Z = RoHS Compliant Part.

Компания «Life Electronics» занимается поставками электронных компонентов импортного и отечественного производства от производителей и со складов крупных дистрибьюторов Европы, Америки и Азии.

С конца 2013 года компания активно расширяет линейку поставок компонентов по направлению коаксиальный кабель, кварцевые генераторы и конденсаторы (керамические, пленочные, электролитические), за счёт заключения дистрибьюторских договоров

Мы предлагаем:

- Конкурентоспособные цены и скидки постоянным клиентам.
- Специальные условия для постоянных клиентов.
- Подбор аналогов.
- Поставку компонентов в любых объемах, удовлетворяющих вашим потребностям.
- Приемлемые сроки поставки, возможна ускоренная поставка.
- Доставку товара в любую точку России и стран СНГ.
- Комплексную поставку.
- Работу по проектам и поставку образцов.
- Формирование склада под заказчика.
- Сертификаты соответствия на поставляемую продукцию (по желанию клиента).
- Тестирование поставляемой продукции.
- Поставку компонентов, требующих военную и космическую приемку.
- Входной контроль качества.
- Наличие сертификата ISO.

В составе нашей компании организован Конструкторский отдел, призванный помогать разработчикам, и инженерам.

Конструкторский отдел помогает осуществить:

- Регистрацию проекта у производителя компонентов.
- Техническую поддержку проекта.
- Защиту от снятия компонента с производства.
- Оценку стоимости проекта по компонентам.
- Изготовление тестовой платы монтаж и пусконаладочные работы.



Тел: +7 (812) 336 43 04 (многоканальный)

Email: org@lifeelectronics.ru