

NCP81174

4/3/2-Phase Synchronous Buck Controller with Power Saving Mode and PWM VID Interface

The NCP81174 is a general-purpose up to four-phase synchronous buck controller. It combines differential voltage sensing, differential phase current sensing, and PWM VID interface to provide accurate regulated power for the computer or graphic controllers. It can receive power saving command (PSI) from processors and operates in single-phase diode emulation mode to obtain high efficiency in light load. Dual-edge multiphase PWM modulation ensures a fast transient response with minimum possible capacitors.

Features

- Output Voltage up to 2.0 V with PWM VID Interface
- Support 1.8 V and 3.3 V VID interface
- Remote Differential Output Voltage Sense
- Differential Current Sense For Each Phase
- 200 kHz – 1000 kHz Switching Frequency
- Power Saving Interface (PSI)
- Power Good Output
- Thermally Compensated Current Monitoring
- Over Current Protection
- Fast Transient Response
- 5 V V_{CC} Shunt Regulator
- Latched OVP and UVP Protections
- QFN–32, 5 x 5 mm, 0.5 mm Pitch Package
- This is a Pb–Free Device

Typical Applications

- GPU and CPU Power
- Graphics Card Applications
- Desktop and Notebook Applications



ON Semiconductor®

www.onsemi.com

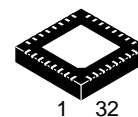

QFN32
MW SUFFIX
CASE 488AM

MARKING DIAGRAM

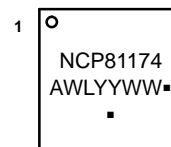

A = Assembly Location
WL = Wafer Lot
YY = Year
WW = Work Week
▪ = Pb–Free Package

(Note: Microdot may be in either location)

ORDERING INFORMATION

Device	Package	Shipping†
NCP81174MNTXG	QFN32 (Pb–Free)	2500 / Tape & Reel

†For information on tape and reel specifications, including part orientation and tape sizes, please refer to our Tape and Reel Packaging Specifications Brochure, BRD8011/D.

NCP81174

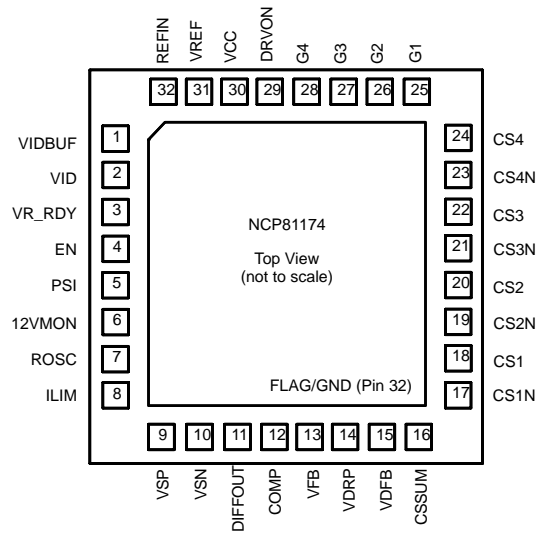

Figure 1. Pinout

NCP81174

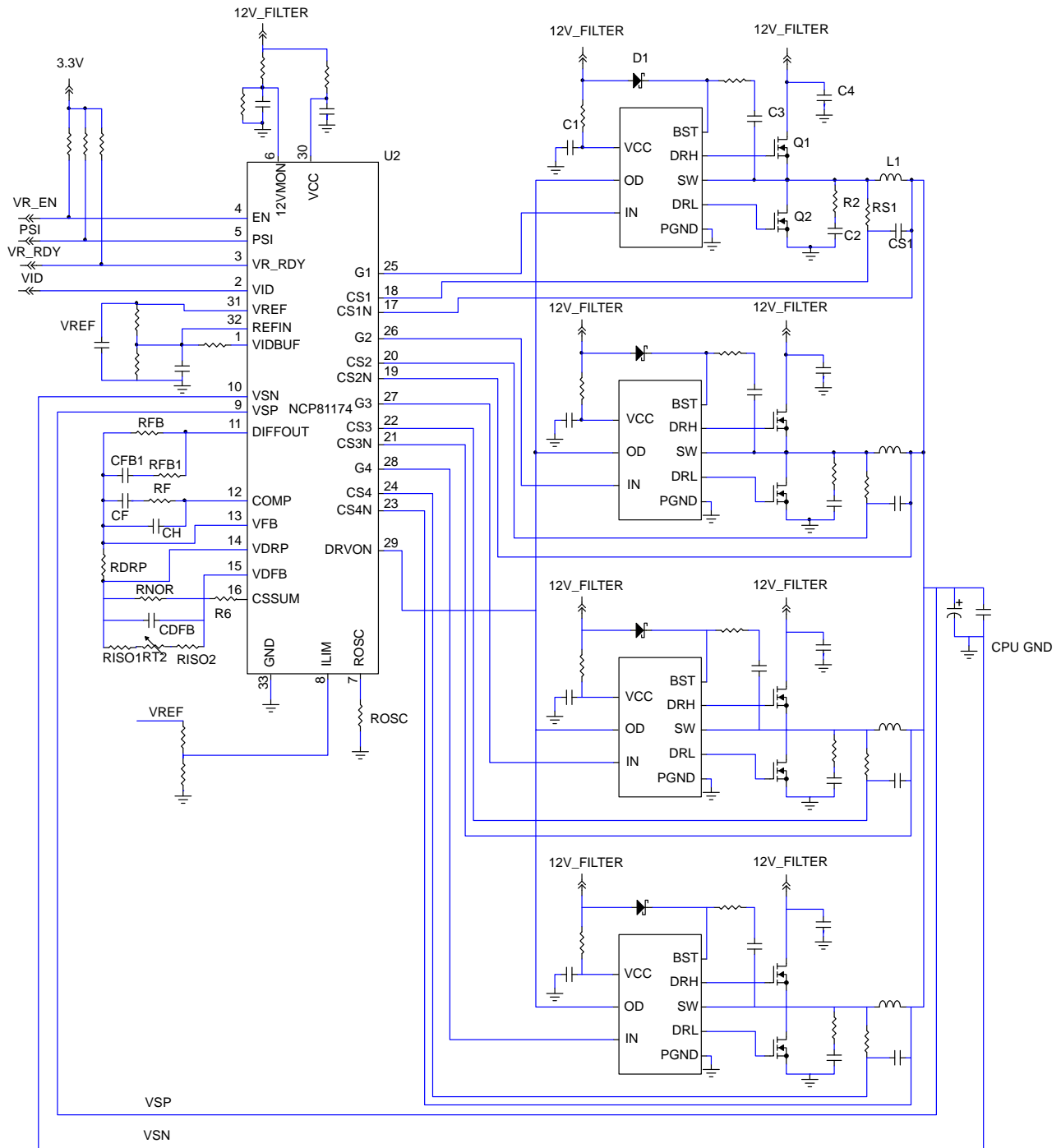

Figure 2. Typical Four Phase Application Circuit with PWM-VID Interface

NCP81174

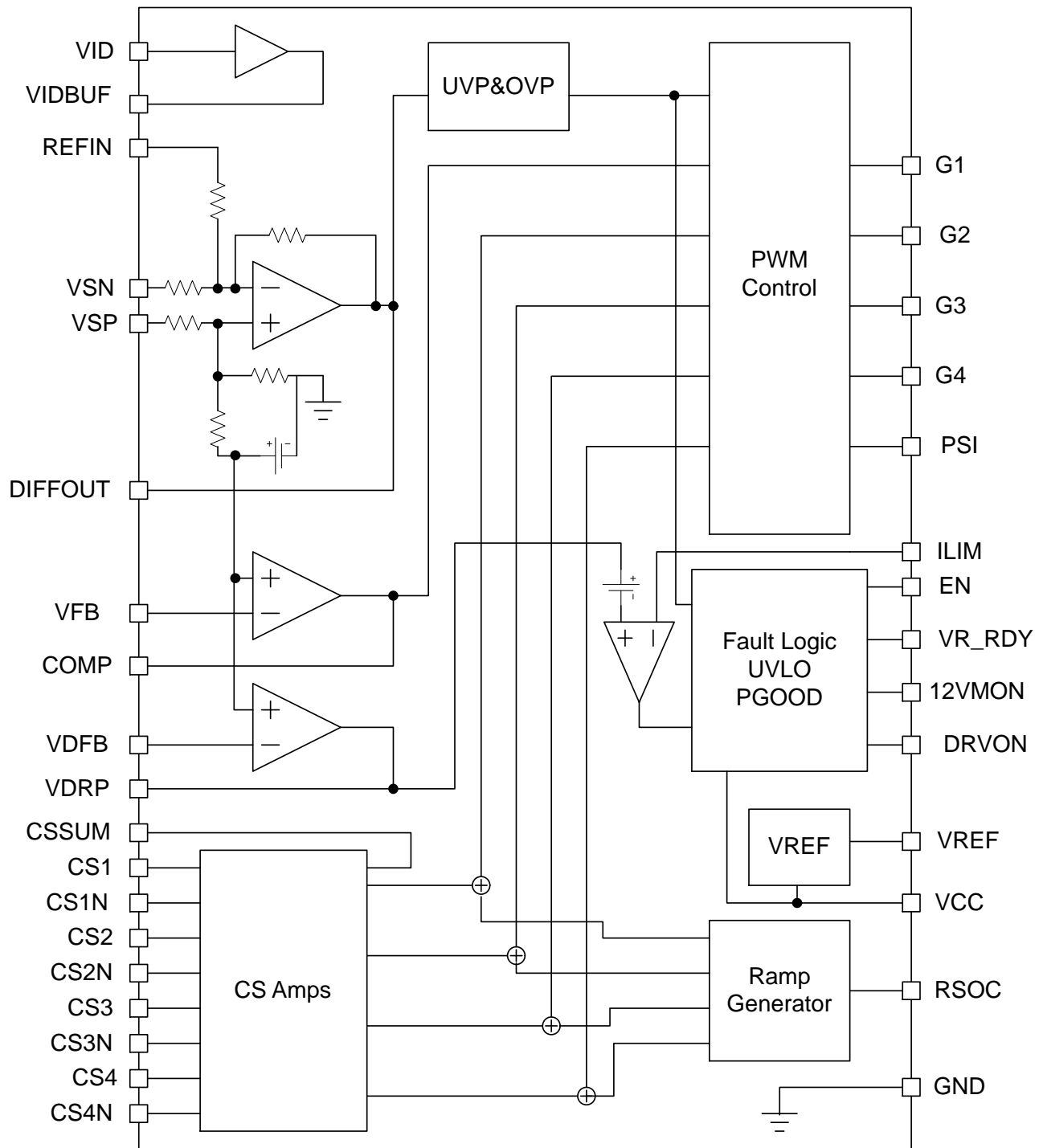

Figure 3. Functional Block Diagram

NCP81174

PIN DESCRIPTION

Pin	Name	Description
1	VIDBUF	VID PWM pulse output from an internal buffer.
2	VID	Voltage ID from processor.
3	VR_RDY	Power good indicator.
4	EN	Chip enable.
5	PSI	Power saving control. Three levels.
6	12VMON	12 V input power rail monitor. It is a divided down voltage from the input power rail, should be kept to less than 4 V at all time.
7	ROSC	A resistance from this pin to ground programs the oscillator frequency.
8	ILIM	Over current shutdown threshold setting.
9	VSP	Non-inverting input to the internal differential remote sense amplifier.
10	VSN	Inverting input to the internal differential remote sense amplifier.
11	DIFFOUT	Output of the differential remote voltage sense amplifier.
12	COMP	Output of the compensation amplifier.
13	VFB	Inverting input of the compensation error amplifier
14	VDRP	Voltage signal proportional to the total current.
15	VDFB	Current summing amplifier inverting input
16	CSSUM	Current summing output signal
17	CS1N	Inverting input to current sense amplifier, phase 1.
18	CS1	Non-inverting input to current sense amplifier, phase 1.
19	CS2N	Inverting input to current sense amplifier, phase 2.
20	CS2	Non-inverting input to current sense amplifier, phase 2.
21	CS3N	Inverting input to current sense amplifier, phase 3.
22	CS3	Non-inverting input to current sense amplifier, phase 3.
23	CS4N	Inverting input to current sense amplifier, phase 4.
24	CS4	Non-inverting input to current sense amplifier, phase 4.
25	G1	Phase 1 PWM output, 3 levels.
26	G2	Phase 2 PWM output, 3 levels.
27	G3	Phase 3 PWM output, 3 levels.
28	G4	Phase 4 PWM output, 3 levels.
29	DRVON	Gate driver enable.
30	VCC	Power supply for the chip. NCP81174 has a built-in 5 V shunt regulator, allowing it to connect to the external 12 V supply through a resistor. Do not connect a 5 V supply to VCC directly.
31	VREF	2.0 V output reference voltage. A 10 nF ceramic capacitor is recommended to connect this pin to ground.
32	REFIN	Reference voltage input for output voltage regulation.
33	FLAG	Thermal pad and analog ground, connected to system ground.

NCP81174

MAXIMUM RATINGS

ELECTRICAL INFORMATION

Pin Symbol	VMAX	VMIN	ISOURCE	ISINK
COMP	5.5 V	-0.3 V	10 mA	10 mA
VDRP	5.5 V	-0.3 V	5 mA	5 mA
VSP	5.5 V	GND - 300 mV	1 mA	1 mA
VSN	GND + 300 mV	GND - 300 mV	1 mA	1 mA
DIFFOUT	5.5 V	-0.3 V	20 mA	20 mA
VR_RDY	5.5 V	-0.3 V	N/A	20 mA
VCC	7.0 V	-0.3 V	N/A	10 mA
ROSC	5.5 V	-0.3 V	1 mA	N/A
PWMVID	5.5 V	-0.3 V (-2 V, <50 ns)		
All Other Pins	5.5 V	-0.3 V		

*All signals referenced to AGND unless otherwise noted.

THERMAL INFORMATION

Rating	Symbol	Value	Unit
Thermal Characteristic, QFN Package (Note 1)	R_{thja}	48.5	°C/W
Junction Temperature Range (Note 2)	T_J	-40 to 125	°C
Operating Ambient Temperature Range	T_A	0 to 100	°C
Maximum Storage Temperature Range	T_{STG}	-55 to +150	°C
Moisture Sensitivity Level, QFN Package	MSL	1	

Stresses exceeding those listed in the Maximum Ratings table may damage the device. If any of these limits are exceeded, device functionality should not be assumed, damage may occur and reliability may be affected.

*The maximum package power dissipation must be observed.

1. JESD 51-5 (1S2P Direct-Attach Method) with 0 LFM.
2. JESD 51-7 (1S2P Direct-Attach Method) with 0 LFM.

NCP81174

ELECTRICAL CHARACTERISTICS

($V_{VCC} = 5\text{ V}$, $V_{REFIN} = 1.0\text{ V}$, $V_{PS1} = 3.3\text{ V}$, typical values are referenced to $T_A = 25^\circ\text{C}$, Min and Max values are referenced to T_A from 0°C to 100°C , unless other noted.)

Characteristics	Test Conditions	Symbol	Min	Typ	Max	Unit
-----------------	-----------------	--------	-----	-----	-----	------

SUPPLY VOLTAGE

System Input Voltage Range		V_{SYS}	7.0		20	V
----------------------------	--	-----------	-----	--	----	---

SUPPLY CURRENT

DC Supply Current	$V_{sys} = 13.2\text{ V}$, $R_{shunt} = 150$			54	60	mA
UVLO Turn-On Current				30	35	mA
VCC UVLO Rising				4.9	5.2	V
VCC UVLO Falling			3.8	4.1		V
VCC Quiescent Current	no switching, PS0 no switching, PS1/PS2	I_{CC}	–	46	–	mA
			–	46	–	mA

SWITCHING FREQUENCY

PS0 Switching Frequency Range		F_{sw}	200		1000	kHz
Switching Frequency Accuracy					10	%
ROSC Output Voltage				2.0	2.05	V

VOLTAGE REFERENCE

VREF Reference Voltage	$I_{REF} = 1\text{ mA}$	V_{VREF}	1.98	2.0	2.02	V
------------------------	-------------------------	------------	------	-----	------	---

PWM MODULATION

Minimum On Time (Note 3)	$F_{sw} = 800\text{ kHz}$		–	30	–	ns
0% Duty Cycle	COMP voltage when the PWM outputs remain HI		–	1.3	–	V
100% Duty Cycle	COMP voltage when the PWM outputs remain HI		–	2.3	–	V
PWM Phase Angle Error	Between adjacent phases		–15		15	°

VOLTAGE ERROR AMPLIFIER

Open-Loop DC Gain (Note 3)				100		dB
Unity Gain Bandwidth (Note 3)				10		MHz
Slew Rate (Note 3)				5		V/ μs
COMP Voltage Swing	$I_{COMP}(\text{source}) = 2\text{ mA}$		3.5	–	–	V
	$I_{COMP}(\text{sink}) = 0.2\text{ mA}$		–	–	50	mV
Non-inverting Voltage Range (Note 3)			0	1.3	3	V
Input Bias Current			–50	0	50	nA
Input Offset Voltage (Note 3)	$V_{SP} = V_{SN} = 1.0\text{ V}$		–1.0		1.0	mV

CURRENT-SENSE AMPLIFIER

Input Bias Current	$CS_x = CS_{xN} = 1.0\text{ V}$		–200	0	200	nA
Input Offset Voltage (Note 3)			–1.0		1.0	mV
Common Mode Input Range (Note 3)			–0.3		2.0	V
Differential Mode Input Range			–120		120	mV
Closed-Loop DC Gain (Note 3)	$0\text{ V} < CS_x - CS_{xN} < 0.1\text{ V}$		5.7	6.0	6.3	V/V
–3dB Gain Bandwidth (Note 3)				10		MHz
Current Sharing Offset			–2.5	–	2.5	mV

Product parametric performance is indicated in the Electrical Characteristics for the listed test conditions, unless otherwise noted. Product performance may not be indicated by the Electrical Characteristics if operated under different conditions.

3. Guaranteed by design, may not be tested.

NCP81174

ELECTRICAL CHARACTERISTICS

($V_{VCC} = 5\text{ V}$, $V_{REFIN} = 1.0\text{ V}$, $V_{PSI} = 3.3\text{ V}$, typical values are referenced to $T_A = 25^\circ\text{C}$, Min and Max values are referenced to T_A from 0°C to 100°C , unless other noted.)

Characteristics	Test Conditions	Symbol	Min	Typ	Max	Unit
-----------------	-----------------	--------	-----	-----	-----	------

CURRENT SUMMING AMPLIFIER

Current Sense Input to CSSUM DC Gain	$-60\text{ mV} < CSx - CSxN < 60\text{ mV}$			-3.93		V/V
Current Sense Input to CSSUM -3 dB Bandwidth (Note 3)	$CL = 10\text{ pF}$ to GND, $RL = 10\text{ k}\Omega$ to GND			4		MHz
CSSUM Output Slew Rate (Note 3)				4		V/ μs
CSSUM Summing Amp Output Offset (Note 3)			-15	0	15	mV
Maximum CSSUM Output Voltage			3.0			V
Minimum CSSUM Output Voltage					0.3	V
Output Source Current (Note 3)			1	-	-	mA
Output Sink Current (Note 3)			1	-	-	mA

DROOP AMPLIFIER VDRP

Input Bias Current (Note 3)			-200		200	nA
Input Offset Voltage (Note 3)	$VSP = VSN = 1.1\text{ V}$		-4.0		4.0	mV
Open Loop DC Gain (Note 3)	$CL = 20\text{ pF}$ to GND including ESD $RL = 1\text{ k}\Omega$ to GND		-	100		dB
Open Loop Unity Gain Bandwidth (Note 3)	$CL = 20\text{ pF}$ to GND including ESD $RL = 1\text{ k}\Omega$ to GND		-	10	-	MHz
Maximum Output Voltage	$I_{SOURCE} = 4.0\text{ mA}$		3	-	-	V
Minimum Output Voltage	$I_{SINK} = 1.0\text{ mA}$		-	-	1	V
Output source current (Note 3)	$V_{out} = 3.0\text{ V}$		4	-	-	mA
Output sink current (Note 3)	$V_{out} = 1.0\text{ V}$		1	-	-	mA

REMOTE VOLTAGE DIFFERENTIAL SENSE AMPLIFIER

Input Bias Current (Note 3)	$VSN = 0\text{ V}$			30		μA
VSP Input Pull down Resistance	DRVON = low DRVON = high			1.5 17		$\text{k}\Omega$
VSP Input Bias Voltage (Note 3)	DRVON = low DRVON = high			0.09 0.66		V
Input Voltage Range (Note 3)			-0.3	-	3.0	V
3dB Bandwidth (Note 3)	$CL = 80\text{ pF}$ to GND, $RL = 10\text{ k}\Omega$ to GND		-	10	-	MHz
Closed Loop DC gain	$VSP - VSN = 0.5$ to 1.3 V		0.98	1.0	1.025	V/V
Maximum Output Voltage	$I_{SOURCE} = 2\text{ mA}$		3.0	-	-	V
Minimum Output Voltage	$I_{SINK} = 2\text{ mA}$		-	-	0.5	V
Output source current (Note 3)	$V_{out} = 3\text{ V}$		2.0	-	-	mA
Output sink current (Note 3)	$V_{out} = 0.5\text{ V}$		2.0	-	-	mA

DRVON

Output High Voltage	Sourcing $500\text{ }\mu\text{A}$		3.0	-	-	V
Output Low Voltage	Sinking $500\text{ }\mu\text{A}$		-	-	0.7	V
Rise Time	CL (PCB) = 20 pF , $\Delta V_o = 10\%$ to 90%		-	20	-	ns

Product parametric performance is indicated in the Electrical Characteristics for the listed test conditions, unless otherwise noted. Product performance may not be indicated by the Electrical Characteristics if operated under different conditions.

3. Guaranteed by design, may not be tested.

NCP81174

ELECTRICAL CHARACTERISTICS

($V_{VCC} = 5\text{ V}$, $V_{REFIN} = 1.0\text{ V}$, $V_{PSI} = 3.3\text{ V}$, typical values are referenced to $T_A = 25^\circ\text{C}$, Min and Max values are referenced to T_A from 0°C to 100°C , unless other noted.)

Characteristics	Test Conditions	Symbol	Min	Typ	Max	Unit
-----------------	-----------------	--------	-----	-----	-----	------

DRVON

Fall Time	CL (PCB) = 20pF, $\Delta V_o = 10\%$ to 90%		–	20	–	ns
-----------	------------------------------------------------	--	---	----	---	----

ENABLE

Enable Threshold	EN rising		–	1.1	1.15	V
	EN falling		0.95	1.0		
EN 3.3V IO Detection Threshold	EN rising			2.5	2.55	V
	EN falling		2.35	2.4		
EN Input Bias Current	External 1k pull-up to 3.3 V		–	–	1.0	μA

POWER SAVE INPUT

PSI High Threshold (3.3 V input logic), Refer to Table 1	Rising Falling	$V_{\text{highPSI}_3.3\text{V}}$	2.05	2.4 2.2	2.55	V
PSI High Threshold (1.8 V input logic), Refer to Table 2	Rising Falling	$V_{\text{highPSI}_1.8\text{V}}$	1.05	1.4 1.2	1.55	V
PSI Low Threshold	Rising Falling	V_{lowPSI}	0.5	0.8 0.6	0.95	V
PSI Input Bias Current (Note 3)			–	–	1.0	μA

PWM OUTPUTS

Output High Voltage	Sourcing 500 μA		3.0	–	–	V
Mid Output Voltage			1.4	1.5	1.6	V
Output Low Voltage	Sinking 500 μA		–	–	0.7	V
Rise Time	CL (PCB) = 50 pF, $\Delta V_o = 10\%$ to 90%		–	10	15	ns
Fall Time	CL (PCB) = 50 pF, $\Delta V_o = 10\%$ to 90%		–	10	15	ns

4/3/2 PHASE DETECTION

Gate Pin Source Current			–	80	–	μA
Gate Pin Threshold Voltage			210	240	265	mV
Phase Detect Timer			–	20	27	μs

VR_RDY – STARTUP

Vout Startup Delay	Measured from EN to Vout Start up from 0 V			1.3		ms
VR_RDY Startup Delay	Measured from EN to VR_RDY assertion			1.9		ms
VR_RDY Shutdown Delay	Measured from EN to VR_RDY de-assertion			200	350	ns
VR_RDY Low Voltage	$I_{\text{VR_RDY}} = 10\text{ mA}$ (sink)		–	–	0.4	V
VR_RDY Leakage Current	VR_RDY = 5 V		–	–	0.2	μA

PROTECTION – OCP, OVP, UVP

Current Limit ILIM to VDRP Gain			0.95	1.0	1.05	V/V
Current Limit ILIM to VDRP Gain in PSI				0.25		V/V

Product parametric performance is indicated in the Electrical Characteristics for the listed test conditions, unless otherwise noted. Product performance may not be indicated by the Electrical Characteristics if operated under different conditions.

3. Guaranteed by design, may not be tested.

NCP81174

ELECTRICAL CHARACTERISTICS

($V_{VCC} = 5\text{ V}$, $V_{REFIN} = 1.0\text{ V}$, $V_{PSI} = 3.3\text{ V}$, typical values are referenced to $T_A = 25^\circ\text{C}$, Min and Max values are referenced to T_A from 0°C to 100°C , unless other noted.)

Characteristics	Test Conditions	Symbol	Min	Typ	Max	Unit
-----------------	-----------------	--------	-----	-----	-----	------

PROTECTION – OCP, OVP, UVP

Current Limit ILIM Input Range			0		2.0	V
Under Voltage Protection (UVP) Threshold	Relative to REFIN Voltage			50%		REFIN
Under Voltage Protection (UVP) Delay				5		μs
Over Voltage Protection (OVP) Threshold	Relative to REFIN Voltage			150%		REFIN
Over Voltage Protection (OVP) Threshold Clamping Voltage				2		V
Over Voltage Protection (OVP) Delay				5		us

12VMON

12VMON Rising				0.94	1.0	V
12VMON Falling			0.65	0.87		V
12VMON Range (Note 3)					4.0	V

PWM–VID BUFFER

Buffer Output Rise Time		T_r		3.0		ns
Buffer Output Fall Time		T_f		3.0		ns
Rising and Falling Edge Delay (Note 3)	$\Delta T = T_r - T_f $	ΔT			0.5	ns
Propagation Delay	$T_{pd} = T_{pHL} = T_{pLH}$	T_{pd}		8.0		ns
Propagation Delay Error (Note 3)	$\Delta T_{pd} = T_{pHL} - T_{pLH}$	ΔT_{pd}			0.5	ns

REFIN

REFIN Discharge Switch ON–Resistance	$I_{REFIN}(\text{sink}) = 2\text{ mA}$			6.0		Ω
REFIN Discharge Time (Note 3)	Measured from EN assertion			100		μs

Product parametric performance is indicated in the Electrical Characteristics for the listed test conditions, unless otherwise noted. Product performance may not be indicated by the Electrical Characteristics if operated under different conditions.

3. Guaranteed by design, may not be tested.

NCP81174

DETAILED DESCRIPTION

General

The NCP81174, a 4/3/2-phase synchronous buck controller with PWM VID interface in a QFN-32 package, provides a compact-footprint power management solution for new generation computing and graphic processors. It receives power saving input (PSI) from processors and operates in 1-phase forced PWM or diode emulation mode to obtain high efficiency in light-load conditions. It can either receive PWMVID from the processor to achieve dynamic voltage control or locally set the reference from an internal precise 2 V regulator. Operating in high switching frequency up to 1 MHz allows employing small size inductor and capacitors. Introduction of dual-edge current

mode multi-phase control results in fast transient response and good dynamic current balance.

Power Operation Modes

The NCP81174 has three power operation modes corresponding to PSI levels as shown in Table 1 and 2. The chip is compatible to different I/O systems. If the upstream controller has a 3.3 V or higher I/O interface, the configuration would follow Table 1, the ENABLE signal needs to be higher than 2.5 V to turn on the chip; If the upstream controller has a 1.8 V I/O interface, the configuration would follow Table 2, the ENABLE signal needs to be higher than 1.1 V only to turn on the chip. The operation mode can be changed on the fly.

Table 1. POWER SAVING INTERFACE (PSI) CONFIGURATIONS (3.3 V I/O, EN > 2.5 V)

PSI Level	Power Mode	Phase Configuration
High (PSI \geq 2.4 V)	PS0	Full Phase, FCCM
Intermediate (0.8V < PSI < 2.4 V)	PS1	1-Phase, FCCM
Low (PSI \leq 0.8 V)	PS2	1-Phase, Auto CCM/DCM

Table 2. POWER SAVING INTERFACE (PSI) CONFIGURATIONS (1.8 V I/O, 2.5 V > EN > 1.1 V)

PSI Level	Power Mode	Phase Configuration
High (PSI \geq 1.4 V)	PS0	Full Phase, FCCM
Intermediate (0.8 V < PSI < 1.4 V)	PS1	1-Phase, FCCM
Low (PSI \leq 0.8 V)	PS2	1-Phase, Auto CCM/DCM

Remote Voltage Sense

A true differential amplifier allows the NCP81174 to measure Vcore voltage feedback with respect to the Vcore ground reference point by connecting the Vcore reference point to VSP, and the Vcore ground reference point to VSN. This configuration keeps ground potential differences between the local controller ground and the Vcore ground reference point from affecting regulation of Vcore between Vcore and Vcore ground reference points. The remote sensing amplifier also subtracts the REFIN (DAC) voltage, thereby producing an unamplified output error voltage at the DIFFOUT pin. This output also has a 1.3 V bias voltage as the floating ground to allow both positive and negative error voltages.

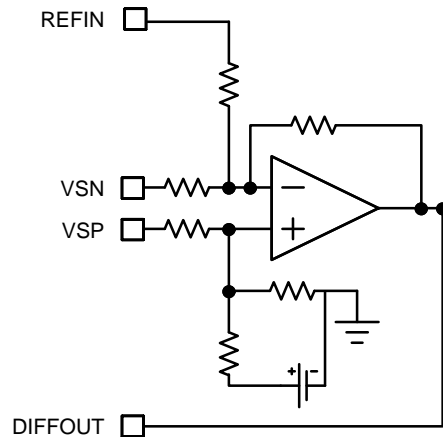

Figure 4. Voltage Remote Sense

Switching Frequency

The Rosc pin provides a 2.0 V reference voltage. The resistor connected to this pin will sink current from the pin to ground. This current is internally mirrored into a capacitor to create an oscillator. The period is proportional to the resistance and the frequency is inversely proportional to the total resistance. The total resistance may be estimated by equation 1. This equation is valid for the individual phase frequency in multi-phase mode PS0 and single phase mode PS1. In PS2, the frequency will be close to set frequency in CCM and scaled down with load current in DCM operation.

$$R_{osc} \cong 20947 \cdot F_{SW}^{-1.1262} \quad (\text{eq. 1})$$

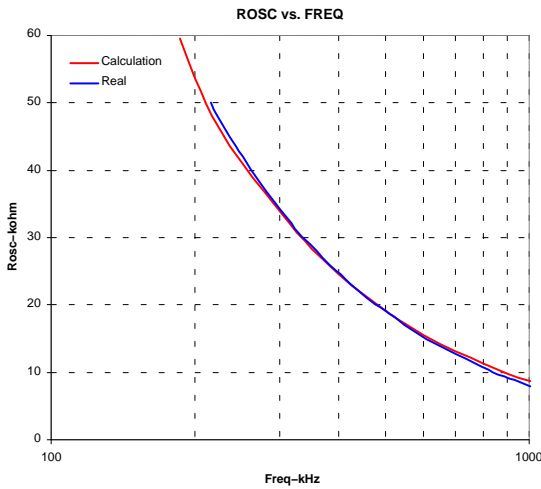

Figure 5. ROSC vs. Frequency

PWM VID

The NCP81174 receives the PWMVID signal from the upstream controller for the Vcore regulation. The signal is decoded internally and passed to the VID buffer output (VIDBUF), where the duty cycle is converted to a corresponding signal between 0 V and 2 V. The VIDBUF high level is derived from a precise 2.0 V reference voltage. The VIDBUF signal is then filtered through the external low pass filter constructed by R_REFADJ and C_REFIN. The filtered output is connected to the REFIN pin. The REFIN is the voltage reference of the Vcore regulator. The output voltage maximum, minimum, and also boot voltage can be calculated with below equations.

$$V_{max} = V_{ref} \cdot \frac{R_{VREF2}}{R_{VREF2} + (R_{VREF1} \parallel R_{REFADJ})} \quad (\text{eq. 2})$$

$$V_{min} = V_{ref} \cdot \frac{R_{VREF2} \parallel R_{REFADJ}}{R_{VREF1} + (R_{VREF2} \parallel R_{REFADJ})} \quad (\text{eq. 3})$$

$$V_{boot} = \frac{V_{max} + V_{min}}{2} \quad (\text{eq. 4})$$

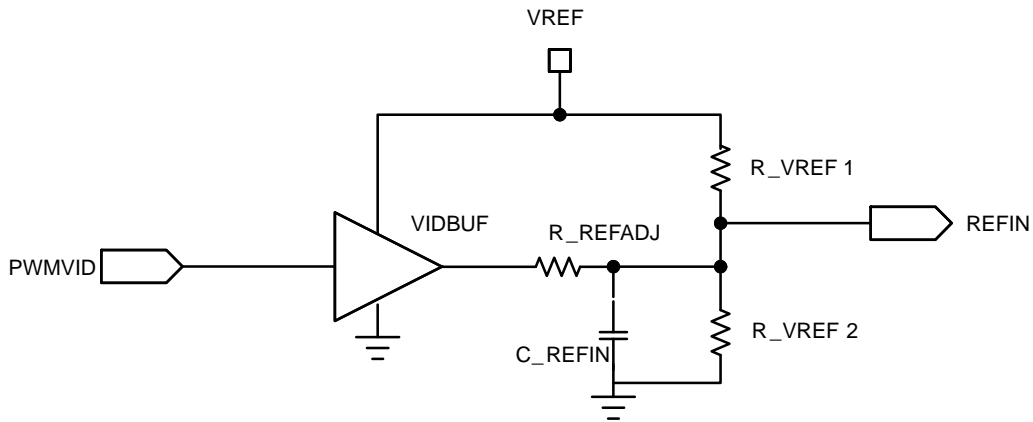

Figure 6. PWM VID Interface

The NCP81174 can decode both 1.8 V and 3.3 V PWMVID output levels. If the EN voltage input is more than 2.5 V, a 3.3 V PWMVID I/O is identified. If EN voltage is above 1.1 V (Overall chip enable threshold) but less than 2.5 V, a 1.8 V PWMVID I/O is assumed.

Soft Start

The NCP81174 has an internal controlled soft start function. The output starts to ramp up following a system reset period after the device is enabled. The device is able to

start up smoothly under an output pre-biased condition without discharging the output before ramping up.

Before the output soft start begins, an internal switch will be turned on to discharge the external filter cap C_REFIN connected to the REFIN pin to reset the DAC setting, the typical on resistance of the switch is around 6 Ω s. After the discharging, internal switch will be turned off to allow external C_REFIN cap to recharge. After 100 μ s, the output voltage ramps up with a fixed slew rate of 1.3 mV/ μ S.

The circuit can be set to start from either all the phases when the input power rails are all available or from phase 1 when only one input power rail is available by presetting the power mode from PSI pin (See Power Operation Modes).

5V Shunt Regulator

The NCP81174 has an internal shunt regulator to generate 5 V from the external power supply (e.g. 12 V). It is recommended to connect three 0603 resistors (450 Ω each) in parallel from a 12 V power supply to the VCC pin.

Thermal Compensation Amplifier with VDRP and VDFB pins

Thermal compensation amplifier is an internal amplifier in the path of droop current feedback for additional adjustment of the gain of summing current and temperature compensation. The way thermal compensation is implemented separately ensures minimum interference to the voltage loop compensation network.

PWM Comparators with Hysteresis and 3rd state of PWM Outputs

Four PWM comparators receive an error signal at their non-inverting input and one of the triangle waves at its inverting input. The output of each comparator generates the PWM outputs G1, G2, G3 and G4.

During the steady state operation, the duty cycle will center on the valley of the triangle waveform, with steady state duty cycle calculated by V_{out}/V_{in} . During a transient event, both high and low comparator output transitions shift phase to the points where the error signal intersects the down and up ramp of the triangle wave.

PWM signals vary between high and low in all phase operation or forced PWM mode. In power saving mode (PS2), PWM signals vary between high and mid level to allow diode emulation.

2/3/4 Phase Operation

Besides 4-phase, the part can be configured to run in 2 or 3-phase mode. In 2-phase mode, phase 1 and 3 should be used to drive the external gate drivers, gate outputs G2 and G4 should be grounded. In 3-phase mode, gate output G4 should be grounded. The current sense inputs of the unused channels should be connected to the Vcore output.

Differential Current Sense Amplifiers and Summing Amplifier

Four differential amplifiers are provided to sense the output current of each phase. The inputs of each current

sense amplifier must be connected across the current sensing element of the phase controlled by the corresponding gate output (G1, G2, G3, or G4). If a phase is unused, the differential inputs to that phase's current sense amplifier must be shorted together and connected to the output.

A voltage is generated across the current sense element (such as an inductor or sense resistor) by the current flowing in that phase. The outputs of four current amplifiers are fed into a summing amplifier to have a summed-up output (CSSUM). Signal of CSSUM combines information of total current of all phases in operation. The gain from the total sense current input to CSSUM (ACSSUM) is ~ 3.93 .

The output of the current sense amplifiers are used to control three functions. First, the output controls the adaptive voltage positioning, where the output voltage is actively controlled according to the output current. Second, the output signal is fed to the current limit circuit. This again is the summed current of all phases in operation. Finally, the individual phase current is connected to the PWM comparator. In this way current balance is accomplished.

Undervoltage Lockout (VCC UVLO) and 12VMON

VCC is constantly monitored for undervoltage lockout (UVLO). Line input (normally 12V) is monitored for undervoltage lockout through 12VMON pin by connecting an appropriate resistor divider from line input to the 12VMON input. The setting of the resistor divider should make the 12VMON voltage less than 4 V at all time. During power-up, both VCC and 12VMON will be monitored. Only after they exceed their individual UVLO thresholds, the full circuit will be activated and ready for soft start if the enable pin is also valid. Both UVLO comparators have hysteresis to avoid chattering. The second function of 12VMON pin is to provide feed-forward input voltage information in PS2 mode, see Power Operation Mode section.

Over Current Protection and Under Voltage Protection

A programmable overcurrent function is incorporated within the IC. The inverting input of the comparator is connected to the ILIM pin. The voltage at this pin (0~2 V) sets the maximum output current the converter can produce. The VREF pin provides a convenient and accurate reference voltage from which a resistor divider can create the overcurrent setpoint voltage. Although not actually disabled, tying the ILIM pin directly to the VREF pin sets the limit above useful levels – effectively disabling overcurrent shutdown. The comparator non-inverting input is the summed current information from the current sense amplifier. The overcurrent event will set PWM low for the rest of the cycle when the current information exceeds the voltage at the ILIM pin. If the overcurrent continuously happens and the output will eventually hit the Under Voltage Protection (UVP) limit and it will be a latched event. The UVP limit is set to 50% below the REFIN voltage. The PWM outputs will stay at mid state until the VCC voltage is removed and re-applied, or the ENABLE input is brought low and then high.

Over Voltage Protection

An output voltage monitor is incorporated. During normal operation, if the output voltage is 50% over the REFIN, the VR_RDY goes low, the DRVON signal remains high, and PWM outputs are set low. The limit will be clamped to 2 V

if 50% over REFIN creates a voltage above the 2 V. The outputs will remain disabled until the V_{CC} voltage is removed and reapplied, or the ENABLE input is brought low and then high.

DESIGN METHODOLOGY

Programming the Current Limit

The VREF pin provides a 2.0 V reference voltage which is divided down with a resistor divider (RLIM1/RLIM2) and fed into the current limit pin ILIM. The current limit function is based on the total sensed current of all phases multiplied by a controlled gain (Acssum*Adrp). DCR sensed inductor current is a function of the winding temperature. If not using thermal compensation, the best approach is to set the maximum current limit based on expected average maximum temperature of the inductor windings,

$$DCR_{Tmax} = DCR_{25} \cdot (1 + 0.00393 \cdot (T_{max} - 25)) \quad (\text{eq. 5})$$

For multiphase controller, the ripple current can be calculated as,

$$I_{PP} = \frac{(V_{in} - N \cdot V_{out}) \cdot V_{out}}{L \cdot F_{SW} \cdot V_{in}} \quad (\text{eq. 6})$$

Therefore calculate the current limit voltage as below,

$$V_{LIMI} \cong A_{CSSUM} \cdot A_{DRP} \cdot DCR_{TMAX} \cdot (I_{MIN_OCP} \cdot + 0.5 \cdot I_{PP}) \quad (\text{eq. 7})$$

$$V_{LIMIT} \cong A_{CSSUM} \cdot A_{DRP} \cdot DCR_{TMAX} \cdot \left(I_{MIN_OCP} \cdot + 0.5 \cdot \frac{(V_{in} - N \cdot V_{out}) \cdot V_{out}}{L \cdot F_{SW} \cdot V_{in}} \right)$$

In Equation 7, A_{CSSUM} and A_{DRP} are the gain of current summing amplifier and droop amplifier.

$$I_{LIMIT}(\text{normal}) \cong \frac{2 \cdot V \cdot R_{LIM2}}{R_{LIM1} + R_{LIM2}} \cdot \frac{3.93 \cdot \frac{R_{NOR} \cdot (R_{ISO1} + R_{ISO2} + R_{T2})}{(R_{NOR} \cdot R_{ISO1} + R_{ISO2} + R_{T2}) \cdot R_{SUM}} \cdot DCR_{25} \cdot (1 + 0.00393 \cdot (T_{inductor} - 25))}{-0.5 \cdot \frac{(V_{in} - V_{out}) \cdot V_{out}}{L \cdot F_{SW} \cdot V_{in}}} \quad (\text{eq. 10})$$

$$I_{LIMIT}(\text{normal}) \cong \frac{\frac{2 \cdot V \cdot R_{LIM2}}{R_{LIM1} + R_{LIM2}} \cdot COEpsi}{3.93 \cdot \frac{R_{NOR} \cdot (R_{ISO1} + R_{ISO2} + R_{T2})}{(R_{NOR} \cdot R_{ISO1} + R_{ISO2} + R_{T2}) \cdot R_{SUM}} \cdot DCR_{25} \cdot (1 + 0.00393 \cdot (T_{inductor} - 25))} - 0.5 \cdot \frac{(V_{in} - V_{out}) \cdot V_{out}}{L \cdot F_{SW} \cdot V_{in}} \quad (\text{eq. 11})$$

N is the number of phases involved in the circuit.

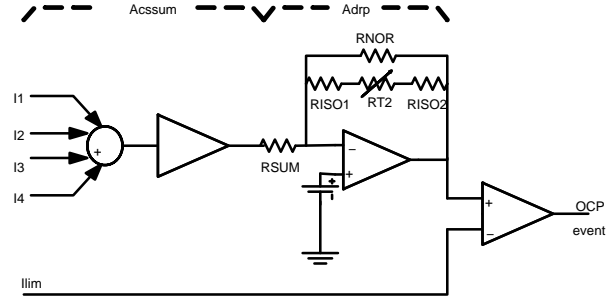

Figure 7. ACSSUM and ADRP

As introduced before, V_{LIMIT} comes from a resistor divider connected to VREF, thus

$$V_{LIMIT} = 2 \cdot V \cdot \frac{R_{LIM2}}{R_{LIM2} + R_{LIM1}} \cdot COEpsi \quad (\text{eq. 8})$$

$$A_{CSSUM} \cong -3.93$$

$$A_{DRP} = -\frac{R_{NOR} \cdot (R_{ISO1} + R_{ISO2} + R_{T2})}{(R_{NOR} + R_{ISO1} + R_{ISO2} + R_{T2}) \cdot R_{SUM}} \quad (\text{eq. 9})$$

R_{ISO1} and R_{ISO2} are in series with R_{T2}, the NTC temperature sense resistor placed near inductor. R_{SUM} is the resistor connecting between pin VDFB and pin CSSUM. In PS0 mode, the current limit follows the Equation 10; In PS1 or PS2, the current limit calculation follows Equation 11, COEpsi is a coefficient for the current limiting related in power saving mode PS1, PS2. COEpsi value is one over the original phase count N. Refer to the PSI and phase shedding section for more details.

Inductor Current Sensing Compensation

The NCP81174 uses the inductor current sensing method. An RC filter is selected to cancel out the impedance from inductor and recover the current information through the inductor’s DCR. This is done by matching the RC time constant of the sensing filter to the L/DCR time constant. The first cut approach is to use a 0.1 uF capacitor for C and then solve for R.

$$R_{sense}(T) = \frac{L}{0.1 \cdot \mu F \cdot DCR_{25C} \cdot (1 + 0.00393 \cdot (T - 25))} \tag{eq. 12}$$

Because the inductor value is a function of load and inductor temperature final selection of R is best done experimentally on the bench by monitoring the VDRP pin and performing a step load test on the actual solution.

Compensation and Output Filter Design

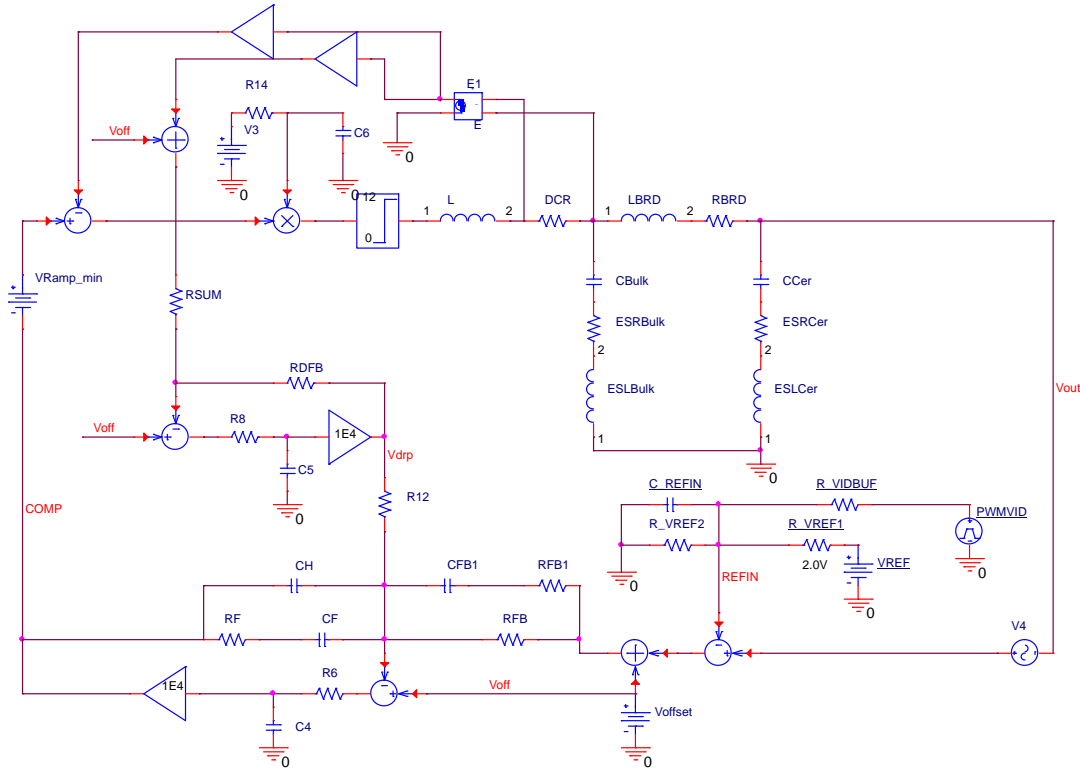

Figure 8. System Average Model

A simple state average model shown in Figure 8 can be used to assist the system design and determine a stable solution.

The goal is to compensate the system such that the resulting gain generates constant output impedance from DC up to the frequency where the ceramic takes over holding the impedance below the target output impedance. By matching the following equations a good set of starting compensation values can be found for a typical mixed bulk and ceramic capacitor type output filter.

$$\frac{1}{2\pi \cdot CF \cdot RF} = \frac{1}{2\pi \cdot (RBRD + ESRBulk) \cdot CBulk} \tag{eq. 13}$$

$$\frac{1}{2\pi \cdot CFB1 \cdot (RFB1 + RFB)} = \frac{1}{2\pi \cdot CCer \cdot (RBRD + ESRBulk)} \tag{eq. 14}$$

Drop Injection and Thermal Compensation

The VDRP signal is generated by summing the sensed output currents for each phase. A droop amplifier is added to adjust the total gain to approximately eight. VDRP is

externally summed into the feedback network by the resistor RDRP. This introduces an offset which is proportional to the output current thereby forcing a controlled, resistive output impedance.

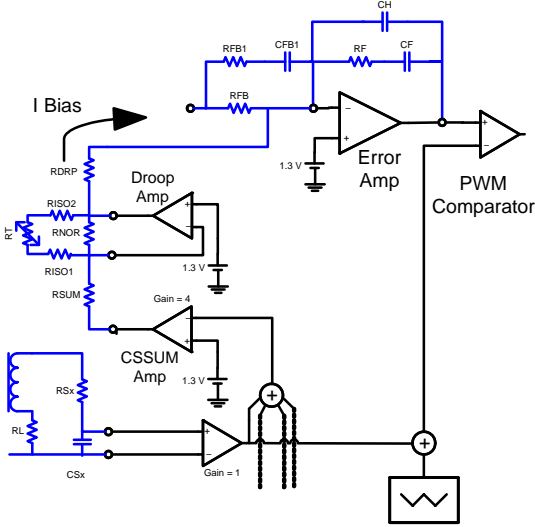

Figure 9. Droop Injection and Thermal Compensation

$$Z_{out}(T) = \frac{R_{FB} \cdot DCR_{25C} \cdot (1 + 0.00393 \cdot (T - 25)) \cdot A_{CSSUM} \cdot A_{DRP}}{R_{DRP}} \quad (\text{eq. 18})$$

By including the NTC RT2 and the series isolation resistors the new equation becomes:

$$Z_{out}(T) = \frac{R_{FB} \cdot DCR_{25C} \cdot (1 + 0.00393 \cdot (T - 25)) \cdot A_{CSSUM} \cdot \frac{R_{NOR} \cdot (R_{ISO1} + R_{ISO2} + R_{T2})}{(R_{NOR} + R_{ISO1} + R_{ISO2} + R_{T2}) \cdot R_{SUM}}}{R_{DRP}} \quad (\text{eq. 19})$$

The typical equation of an NTC is based on a curve fit Equation 20:

$$RT2(T) = RT2_{25C} \cdot e^{\beta \left[\left(\frac{1}{273 + T} \right) - \left(\frac{1}{298} \right) \right]} \quad (\text{eq. 20})$$

Figure 10 shows an example of the comparison of the compensated output impedance and uncompensated output impedance varying with temperature.

RDRP determines the target output impedance by the basic equation:

$$\frac{V_{out}}{I_{out}} = Z_{out} = \frac{R_{FB} \cdot DCR \cdot A_{CSSUM} \cdot A_{DRP}}{R_{DRP}} \quad (\text{eq. 15})$$

$$R_{DRP} = \frac{R_{FB} \cdot DCR \cdot A_{CSSUM} \cdot A_{DRP}}{Z_{out}} \quad (\text{eq. 16})$$

The value of the inductor's DCR is a function of temperature according to Equation 17:

$$DCR(T) = DCR_{25C} \cdot (1 + 0.00393 \cdot (T - 25)) \quad (\text{eq. 17})$$

Actual DCR increases by temperature. The system can be thermally compensated to cancel this effect to a great degree by adding an NTC in parallel with RNOR to reduce the droop gain as the temperature increases. The NTC device is nonlinear. Putting a resistor in series with the NTC helps make the device appear more linear with temperature. The series resistor is split and inserted on both sides of the NTC to reduce noise injection into the feedback loop. The recommended total value for RISO1 plus RISO2 is approximately 1.0 kΩ.

The output impedance varies with inductor temperature by the equation:

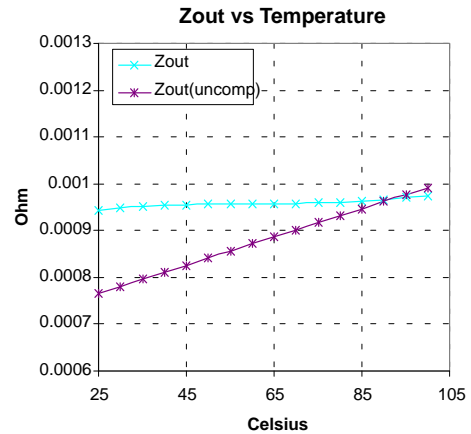

Figure 10. Zout vs. Temperature (10 kΩ NTC with a β value of 3740)

NCP81174

SYSTEM TIMING DIAGRAM

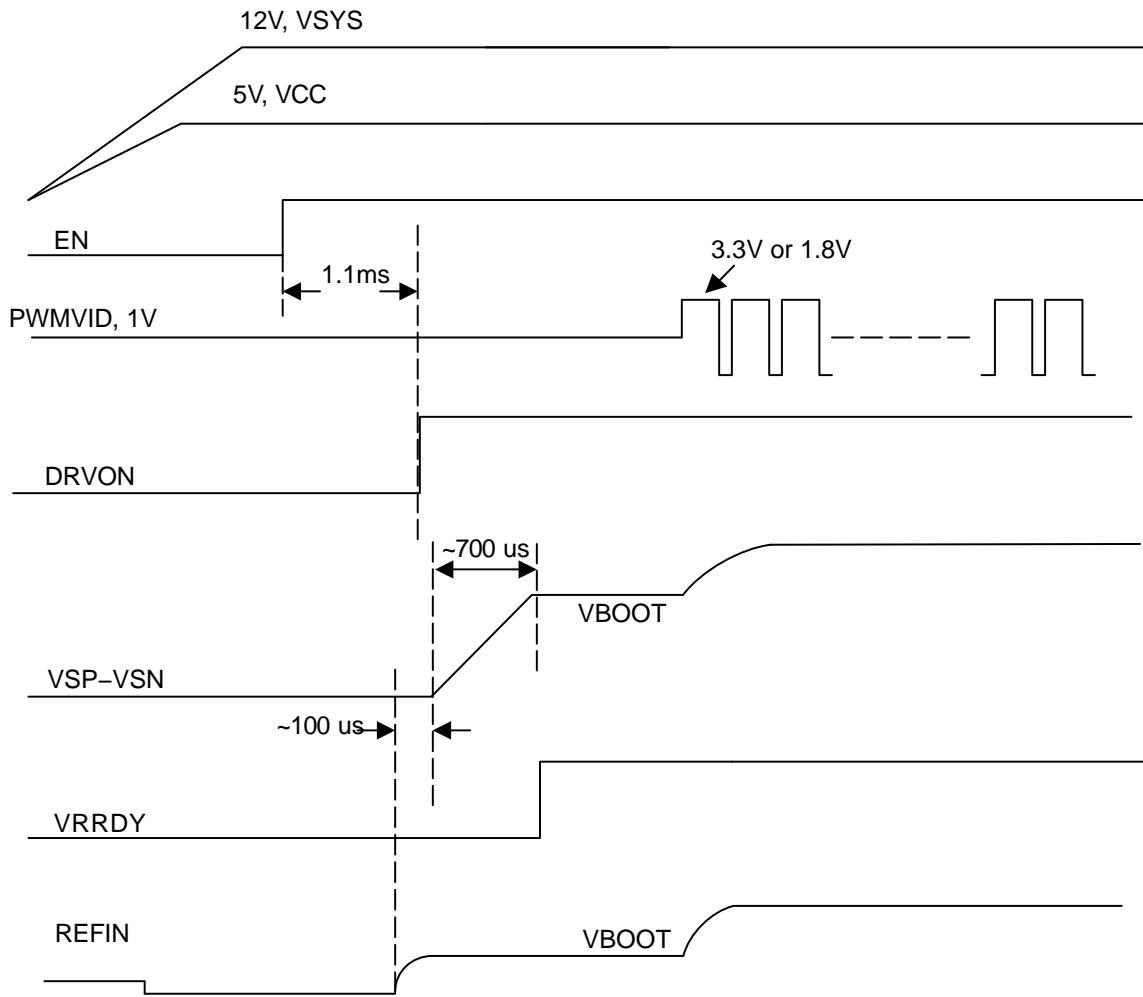
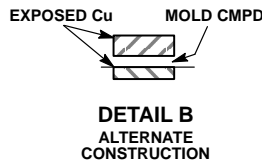
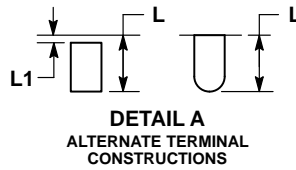
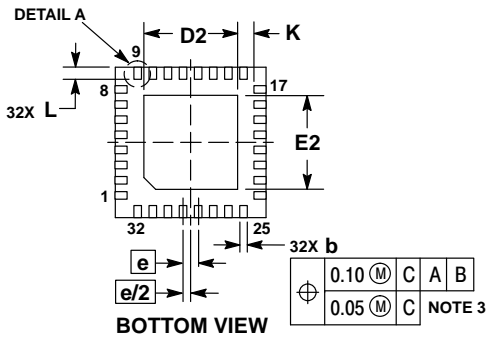
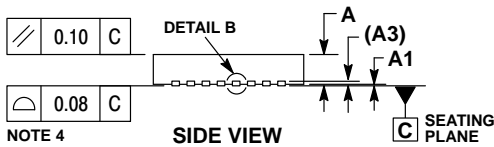
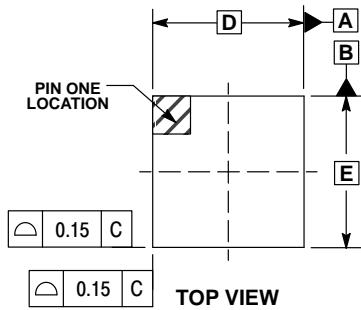

Figure 11. System Timing Diagram

NCP81174

PACKAGE DIMENSIONS

QFN32 5x5, 0.5P
CASE 488AM
ISSUE A



NOTES:

1. DIMENSIONS AND TOLERANCING PER ASME Y14.5M, 1994.
2. CONTROLLING DIMENSION: MILLIMETERS.
3. DIMENSION b APPLIES TO PLATED TERMINAL AND IS MEASURED BETWEEN 0.15 AND 0.30MM FROM THE TERMINAL TIP.
4. COPLANARITY APPLIES TO THE EXPOSED PAD AS WELL AS THE TERMINALS.

DIM	MILLIMETERS	
	MIN	MAX
A	0.80	1.00
A1	---	0.05
A3	0.20	REF
b	0.18	0.30
D	5.00	BSC
D2	2.95	3.25
E	5.00	BSC
E2	2.95	3.25
e	0.50	BSC
K	0.20	---
L	0.30	0.50
L1	---	0.15

RECOMMENDED SOLDERING FOOTPRINT*

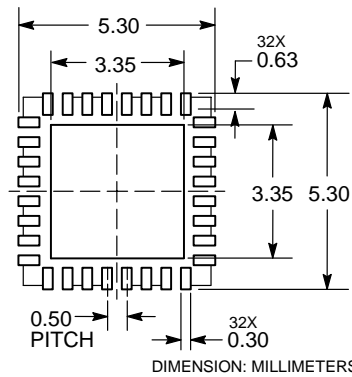

*For additional information on our Pb-Free strategy and soldering details, please download the ON Semiconductor Soldering and Mounting Techniques Reference Manual, SOLDERRM/D.

ON Semiconductor and are registered trademarks of Semiconductor Components Industries, LLC (SCILLC). SCILLC owns the rights to a number of patents, trademarks, copyrights, trade secrets, and other intellectual property. A listing of SCILLC's product/patent coverage may be accessed at www.onsemi.com/site/pdf/Patent-Marking.pdf. SCILLC reserves the right to make changes without further notice to any products herein. SCILLC makes no warranty, representation or guarantee regarding the suitability of its products for any particular purpose, nor does SCILLC assume any liability arising out of the application or use of any product or circuit, and specifically disclaims any and all liability, including without limitation special, consequential or incidental damages. "Typical" parameters which may be provided in SCILLC data sheets and/or specifications can and do vary in different applications and actual performance may vary over time. All operating parameters, including "Typicals" must be validated for each customer application by customer's technical experts. SCILLC does not convey any license under its patent rights nor the rights of others. SCILLC products are not designed, intended, or authorized for use as components in systems intended for surgical implant into the body, or other applications intended to support or sustain life, or for any other application in which the failure of the SCILLC product could create a situation where personal injury or death may occur. Should Buyer purchase or use SCILLC products for any such unintended or unauthorized application, Buyer shall indemnify and hold SCILLC and its officers, employees, subsidiaries, affiliates, and distributors harmless against all claims, costs, damages, and expenses, and reasonable attorney fees arising out of, directly or indirectly, any claim of personal injury or death associated with such unintended or unauthorized use, even if such claim alleges that SCILLC was negligent regarding the design or manufacture of the part. SCILLC is an Equal Opportunity/Affirmative Action Employer. This literature is subject to all applicable copyright laws and is not for resale in any manner.

PUBLICATION ORDERING INFORMATION

LITERATURE FULFILLMENT:
Literature Distribution Center for ON Semiconductor
P.O. Box 5163, Denver, Colorado 80217 USA
Phone: 303-675-2175 or 800-344-3860 Toll Free USA/Canada
Fax: 303-675-2176 or 800-344-3867 Toll Free USA/Canada
Email: orderlit@onsemi.com

N. American Technical Support: 800-282-9855 Toll Free
USA/Canada
Europe, Middle East and Africa Technical Support:
Phone: 421 33 790 2910
Japan Customer Focus Center
Phone: 81-3-5817-1050

ON Semiconductor Website: www.onsemi.com
Order Literature: <http://www.onsemi.com/orderlit>
For additional information, please contact your local Sales Representative

Компания «Life Electronics» занимается поставками электронных компонентов импортного и отечественного производства от производителей и со складов крупных дистрибьюторов Европы, Америки и Азии.

С конца 2013 года компания активно расширяет линейку поставок компонентов по направлению коаксиальный кабель, кварцевые генераторы и конденсаторы (керамические, пленочные, электролитические), за счёт заключения дистрибьюторских договоров

Мы предлагаем:

- Конкурентоспособные цены и скидки постоянным клиентам.
- Специальные условия для постоянных клиентов.
- Подбор аналогов.
- Поставку компонентов в любых объемах, удовлетворяющих вашим потребностям.
- Приемлемые сроки поставки, возможна ускоренная поставка.
- Доставку товара в любую точку России и стран СНГ.
- Комплексную поставку.
- Работу по проектам и поставку образцов.
- Формирование склада под заказчика.
- Сертификаты соответствия на поставляемую продукцию (по желанию клиента).
- Тестирование поставляемой продукции.
- Поставку компонентов, требующих военную и космическую приемку.
- Входной контроль качества.
- Наличие сертификата ISO.

В составе нашей компании организован Конструкторский отдел, призванный помогать разработчикам, и инженерам.

Конструкторский отдел помогает осуществить:

- Регистрацию проекта у производителя компонентов.
- Техническую поддержку проекта.
- Защиту от снятия компонента с производства.
- Оценку стоимости проекта по компонентам.
- Изготовление тестовой платы монтаж и пусконаладочные работы.



Тел: +7 (812) 336 43 04 (многоканальный)
Email: org@lifeelectronics.ru