

## OXU3100, USB SuperSpeed 3.0 to SATA Controller

### Highlights

- **General Features**
  - USB SuperSpeed 3.0 to SATA storage controller
- **Key Features**
  - USB 3.0 to SATA storage controller
  - Integrated USB 3.0 / USB 2.0 PHY
  - Integrated SATA II compliant core and PHY
    - Supports 3.0Gbps and 1.5Gbps interfaces
  - Support for UAS/UASP (USB attached SCSI Protocol) delivering maximum throughput
  - Support for BOT (Bulk only Transport)
  - Support for USB Mass Storage Class
  - SPI interface for serial flash
  - Secondary SPI for simple interface to external system components such as LCD display
  - 9 GPIOs allow easy product customization
  - In-field update of firmware via USB
    - Internal regulator for core voltage
  - 3.3V supply voltage
    - Internal regulator for core voltage

*The OXU3100 is a low power storage controller bridging between USB SuperSpeed 3.0 and a SATA hard disk.*

Fully compliant with the USB 3.0 Specification, the OXU3100 is optimized for bus-powered applications and supports a number of power saving modes, including SATA Interface Power Management (IPM), which allows additional power saving when connected to an HDD that also supports IPM.

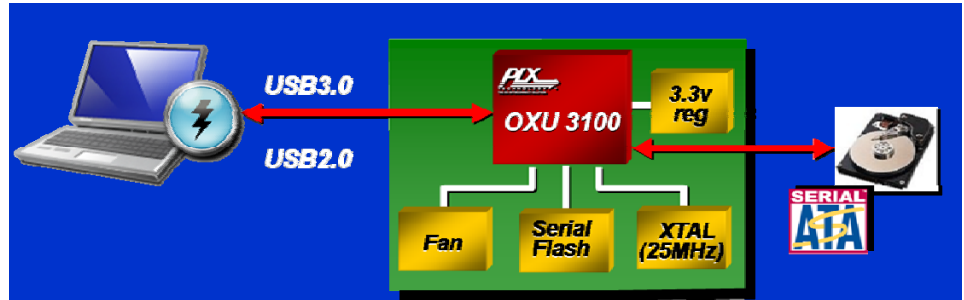

The OXU3100 is a highly integrated device and requires a minimum number of external components. Embedded in the device are a USB 3.0 / 2.0 PHY and device controller, SATA II PHY, internal voltage regulator and Pulse Width Modulators (PWMs) for LED control. The OXU3100 requires only a single external crystal.

The OXU3100 is supported by a comprehensive support package that includes evaluation boards, reference designs, and software development kit.

### USB SuperSpeed 3.0

The embedded USB 3.0 PHY supports SuperSpeed, High Speed and Full Speed modes, using either bulk-only transport Mass Storage Class device protocol or the new USB Attached SCSI Protocol (UASP). Its fast read and write transfers ensure that the maximum possible host performance is maintained.

### SATA Interface

The embedded 3GHz SATA host interfaces supports the latest revisions of the SATA II specifications. Interface speeds of 3GHz and 1.5GHz deliver maximum performance with minimum latency for external SATA storage.

### Power Management

The OXU3100 provides OEMs with a range of power saving modes to ensure minimal power consumption in all configurations, including:

- USB 3.0 U0 – U3 power states
- USB 2.0 standby / suspend states
- SATA Interface Power Management (IPM)

## OXU3100, USB SuperSpeed 3.0 to SATA Controller

### Embedded Processor

The on-chip RISC processor enables a whole new series of standalone consumer electronic product to be developed in a simple C programming environment.

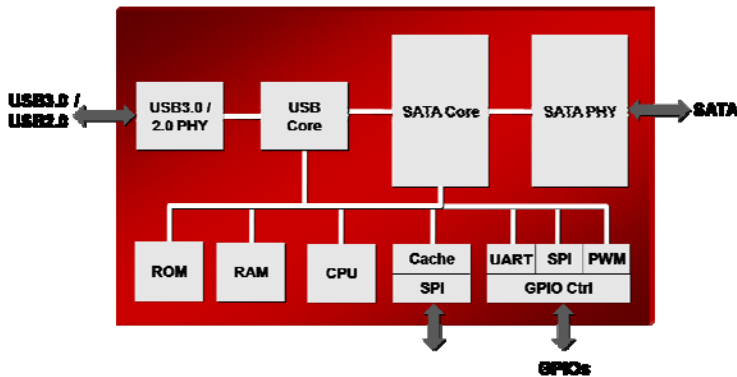

OXU3100 Block Diagram

### Development Support

For external PC storage solutions, PLX Technology offers a comprehensive support package including:

- Reference designs comprising both hardware and software components
- Evaluation boards with pre-built application firmware
- Software Development Kit (SDK) comprising source code and debug boards
- Extensive range of application notes to shorten learning curves and simplify implementation

### Product Ordering Information

Part Number	Description
OXU3100- AANC G	USB3.0 to SATA controller

PLX Technology, Inc. All rights reserved. PLX and the PLX logo are trademarks of PLX Technology, Inc. All other product names that appear in this material are for identification purposes only and are acknowledged to be trademarks or registered trademarks of their respective companies. Information supplied by PLX is believed to be accurate and reliable, but PLX assumes no responsibility for any errors that may appear in this material. PLX reserves the right, without notice, to make changes in product design or specification.

Visit [www.plxtech.com/OXU3100](http://www.plxtech.com/OXU3100) for more information.

# Mouser Electronics

Authorized Distributor

Click to View Pricing, Inventory, Delivery & Lifecycle Information:

[PLX Technology:](#)

[OXU3100-AANC G](#)

Компания «Life Electronics» занимается поставками электронных компонентов импортного и отечественного производства от производителей и со складов крупных дистрибьюторов Европы, Америки и Азии.

С конца 2013 года компания активно расширяет линейку поставок компонентов по направлению коаксиальный кабель, кварцевые генераторы и конденсаторы (керамические, пленочные, электролитические), за счёт заключения дистрибьюторских договоров

Мы предлагаем:

- Конкурентоспособные цены и скидки постоянным клиентам.
- Специальные условия для постоянных клиентов.
- Подбор аналогов.
- Поставку компонентов в любых объемах, удовлетворяющих вашим потребностям.
- Приемлемые сроки поставки, возможна ускоренная поставка.
- Доставку товара в любую точку России и стран СНГ.
- Комплексную поставку.
- Работу по проектам и поставку образцов.
- Формирование склада под заказчика.
- Сертификаты соответствия на поставляемую продукцию (по желанию клиента).
- Тестирование поставляемой продукции.
- Поставку компонентов, требующих военную и космическую приемку.
- Входной контроль качества.
- Наличие сертификата ISO.

В составе нашей компании организован Конструкторский отдел, призванный помогать разработчикам, и инженерам.

Конструкторский отдел помогает осуществить:

- Регистрацию проекта у производителя компонентов.
- Техническую поддержку проекта.
- Защиту от снятия компонента с производства.
- Оценку стоимости проекта по компонентам.
- Изготовление тестовой платы монтаж и пусконаладочные работы.



Тел: +7 (812) 336 43 04 (многоканальный)

Email: [org@lifeelectronics.ru](mailto:org@lifeelectronics.ru)