

Ordering a market-ready enclosure® is made fast and affordable with our complete in-house capabilities. New Age provides machined openings to fit your PCB, pad printing for your graphics, custom enclosures, custom colors, final assembly, testing and fulfillment services to save you additional time and money. Ask your representative for a free quote today 805-595-1310.

## ***Fast and Affordable Customization***

**CNC Modifications  
Pad Printing  
Colored Resins  
EMI/RF Shielding  
Custom Enclosure  
Assembly & Testing**

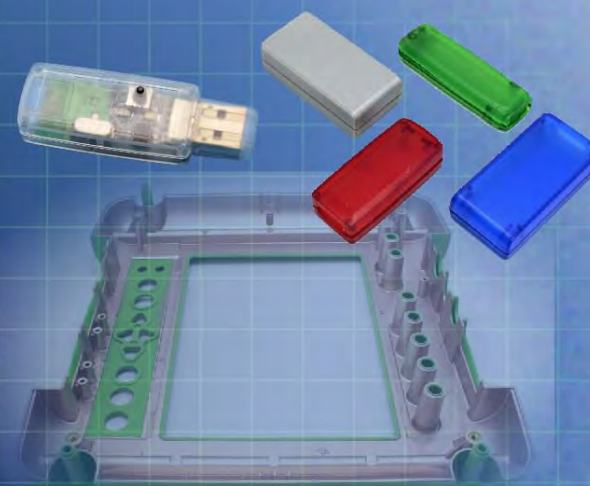

ISO quality  
off-the-shelf  
to market-ready®

# **NEW AGE ENCLOSURES**

[www.NewAgeEnclosures.com](http://www.NewAgeEnclosures.com)

4330 Santa Fe Road • San Luis Obispo, CA 93401 • T 805.595.1310 • F 805.595.1024

SUGGESTION: END CAN BE MOLDED IN A TRANSLUCENT MATERIAL OR ALTERNATE COLOR.

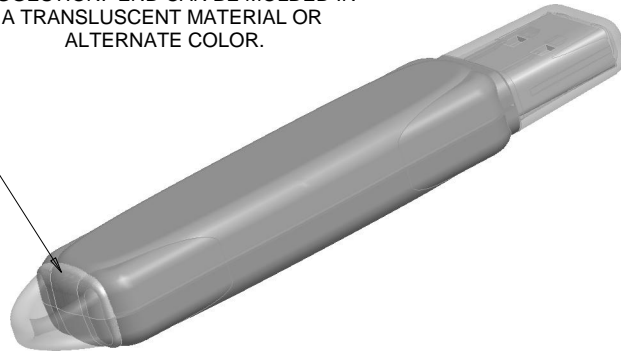

SCALE 1.250

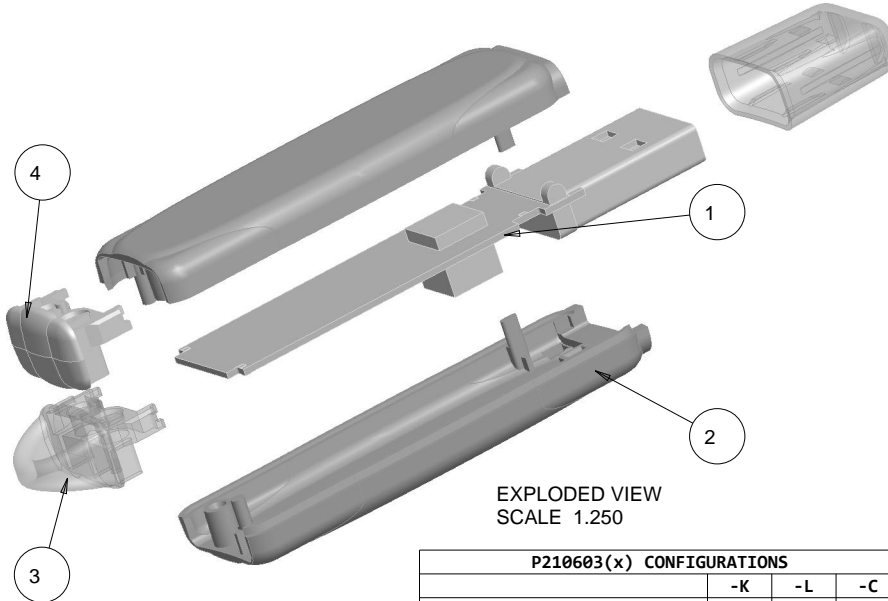

EXPLODED VIEW  
SCALE 1.250

P210603(x) CONFIGURATIONS			
	-K	-L	-C
P210603 CASE HALF	2	2	
P210603 END w/ KEYRING *	1		
P210603 END *		1	
P210603 CAP			1

\* = ENCLOSURE IS TO BE ASSEMBLED USING THE "210603 END" OR "210603 END w/ KEYRING" NOT BOTH. SEE NOTE 8

ITEM	DESCRIPTION	MATERIAL	COLOR	QTY.
5	210603 USB CAP - STANDARD	SOLD SEPARATELY	BLACK or WHITE	1
4	210603 END	ABS	BLACK or WHITE	1
3	210603 END w/ KEYRING	ABS	BLACK or WHITE	1
2	210603 CASE HALF - STANDARD	ABS	BLACK or WHITE	2
1	210603 PCB - REFERENCE	CUSTOMER SUPPLIED	.032" THICK	1

**BILL OF MATERIALS**

R E V I S I O N					
REV.	DRAWN BY	ECO No	DESCRIPTION	DATE	APPROVED
1	M BOYER		PRELIMINARY RELEASE	07-Jul-06	D.C.
	M BOYER		REVISION LIST CONDENSED - SEE REV 10 OR PRIOR		
10.2	M BOYER	0211	NOTE CHANGE	13-Jan-11	D.C.
10.3	M BOYER	0311	REMOVE "LENS" FROM DRAWING LANGUAGE	08-Feb-11	D.C.
10.4	M BOYER	0611	UPDATE TITLE FROM "USB DEVICE" TO "USB STICK"	01-Mar-11	D.C.
10.5	M BOYER	2711	MARK ASSEMBLY DIMENSIONS AS "PRESS FIT"	21-Oct-11	

**NOTES: UNLESS OTHERWISE SPECIFIED**

- DIMENSIONS TO BE SYMMETRICAL ABOUT CENTERLINES WITHIN .003 T.I.R.
- CORNERS DRAWN SHARP TO BE R.005 MAXIMUM.
- EXTERIOR SURFACE TEXTURE TO BE LIGHT EDM FINISH. EQUIVELANT TO MT-11010.
- INTERIOR SURFACE TEXTURE TO BE: NONE.
- ALL INSIDE RADII .010R. UNLESS OTHERWISE SPECIFIED.
- ALL EXTERNAL DIMENSIONS AFFECTED BY THE DRAFT APPLY AT THE LARGE END OF THE FEATURE, AND ALL INTERNAL FEATURES AFFECTED BY THE DRAFT APPLY AT THE SMALL END OF THE FEATURE UNLESS OTHERWISE SPECIFIED.
- 1 DEGREES DRAFT IN THE DIRECTION OF PULL IS PERMISSIBLE UNLESS OTHERWISE SPECIFIED.
- THIS ENCLOSURE IS A PRESS FIT ASSEMBLY. FOR PERMANENT CLOSURE: A DROP ADHESIVE OR ULTRASONIC WELDING IS REQUIRED.
- MATERIAL / COLOR: BLACK OR WHITE ARE STANDARD ABS COLORS. CUSTOM MATERIALS AND COLORS ARE AVAILABLE UPON REQUEST FOR QUOTE.
- PCB SIZES ARE RECOMMENDATIONS ONLY. FINAL SIZES AND VERIFICATION OF IT'S FIT ARE THE SOLE RESPONSIBILITY OF EACH OWNER. SOLID MODELS ARE AVAILABLE FOR DOWNLOAD AT OUR WEBSITE.

THIRD ANGLE PROJECTION 	TOLERANCES: UNLESS OTHERWISE SPECIFIED DIMENSIONS ARE IN U.S. INCHES. X.XX = .015 X.XXXX = .001 X.XXX = .010 X.X° = 1°		<b>NEW AGE ENCLOSURES</b> 4330 Santa Fe Road San Luis Obispo, CA. 93401 ph. (805) 595-1310 fax (805) 595-1024 <a href="http://www.newageenclosures.com">www.newageenclosures.com</a>
	DO NOT SCALE DRAWING		
NOTICE: THE INFORMATION AND DATA CONTAINED HEREIN IS CONSIDERED PROPRIETARY TO ALLTEC INTEGRATED MFG INC & SHALL REMAIN THE EXCLUSIVE PROPERTY OF ALLTEC INTEGRATED MFG INC. THE HOLDER WILL ASSUME CUSTODY AND CONTROL THAT THIS DOCUMENT WILL NOT BE COPIED, REPRODUCED, OR DISCLOSED WITHOUT THE EXPRESS WRITTEN CONSENT OF ALLTEC INTEGRATED MFG INC. POSSESSION OF THIS DOCUMENT DOES NOT CONSTITUTE A GRANT TO MANUFACTURE ANY ITEMS. ©2011			Customer's Part No: 210603
APPROVAL	BY	DATE	
CHECK			
ENG.			
SCALE	AS NOTED		
DRAWN BY	07-Jul-06		SIZE
M BOYER			A
DRAWING NAME		SHEET	REV.DOC
210603_R10_5		1 OF 7	10.5



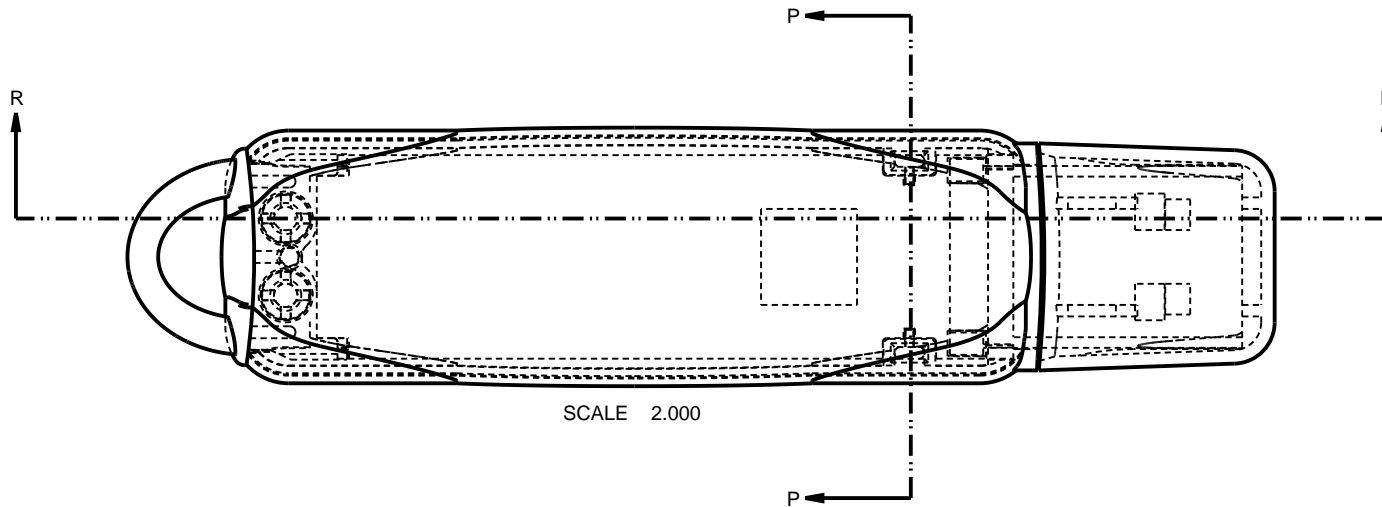

SCALE 2.000

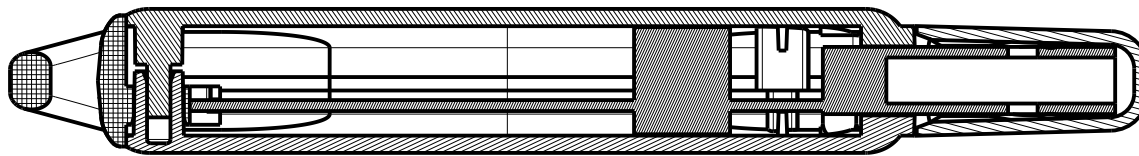

SECTION R-R

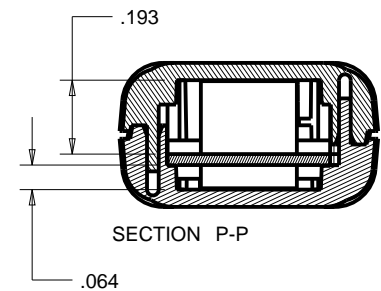

SECTION P-P

TOLERANCES: UNLESS OTHERWISE SPECIFIED DIMENSIONS ARE IN U.S. INCHES. X.XX = .015 X.XXXX = .001 X.XXX = .010 X.X° = 1°		<b>NEW AGE ENCLOSURES</b> 4330 Santa Fe Road San Luis Obispo, CA. 93401 ph. (805) 595-1310 fax (805) 595-1024 <a href="http://www.newageenclosures.com">www.newageenclosures.com</a>				
NEW AGE ENCLOSURES Customer's Part No: 210603						
APPROVAL	BY	DATE	<b>STANDARD - USB STICK          PXX-210603X ASSEMBLY</b>			
CHECK						
ENG.						
SCALE	AS NOTED					
DRAWN BY			SIZE	DRAWING NAME	SHEET	REV.DOC
M BOYER		07-Jul-06	A	210603_R10_5	2 OF 7	10.5

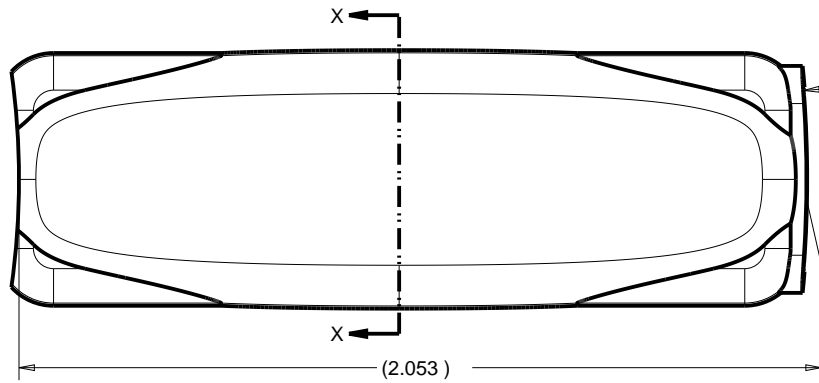

SCALE 2.000

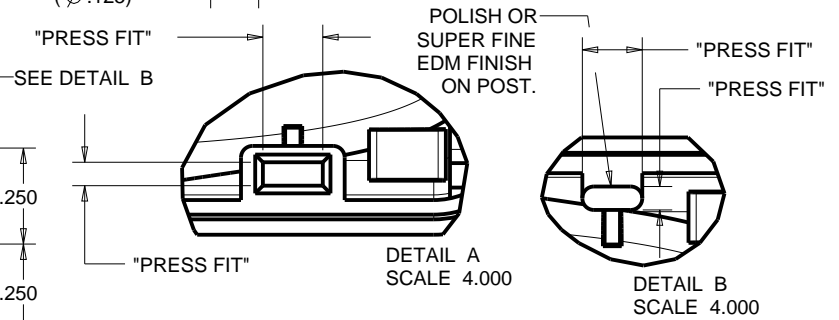
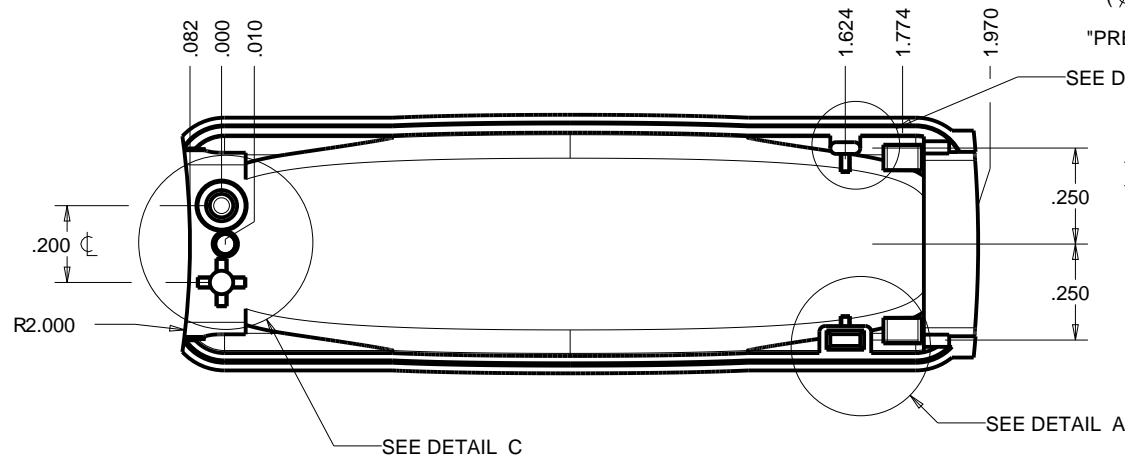
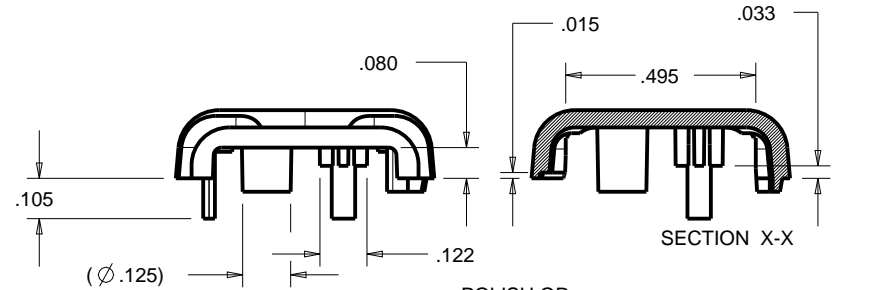
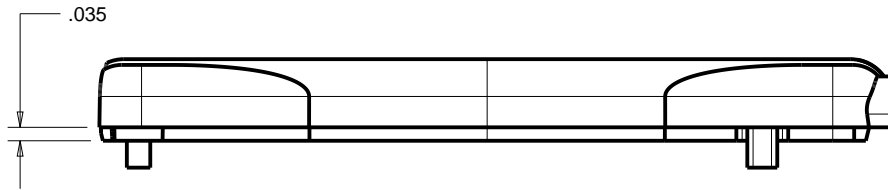
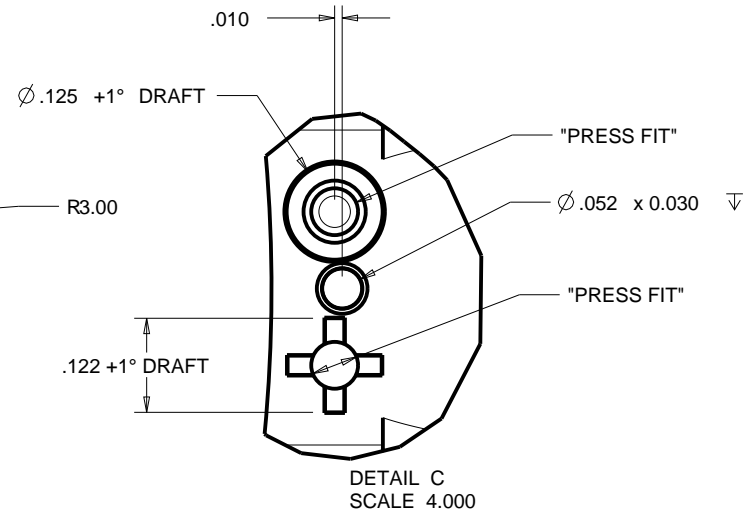

TOLERANCES: UNLESS OTHERWISE SPECIFIED  
DIMENSIONS ARE IN U.S. INCHES.  
X.XX = .015 X.XXXX = .001  
X.XXX = .010 X.X° = 1°

NEW AGE ENCLOSURES  
Customer's Part No: 210603

APPROVAL	BY	DATE
CHECK		
ENG.		
SCALE	AS NOTED	
DRAWN BY	07-Jul-06	
M BOYER		

**NEW AGE ENCLOSURES**  
4330 Santa Fe Road San Luis Obispo, CA. 93401  
ph. (805) 595-1310 fax (805) 595-1024  
[www.newageenclosures.com](http://www.newageenclosures.com)

<b>STANDARD - USB STICK PXX-210603X ASSEMBLY</b>		SHEET	REV.DOC
SIZE	DRAWING NAME	3 OF 7	10.5
A	210603_R10_5		

**210603 END**  
 WITH KEY RING AND WITHOUT.  
 PLEASE SPECIFY PREFERENCE WHEN ORDERING

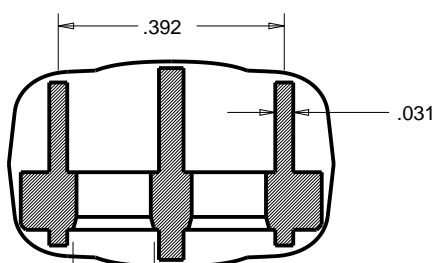
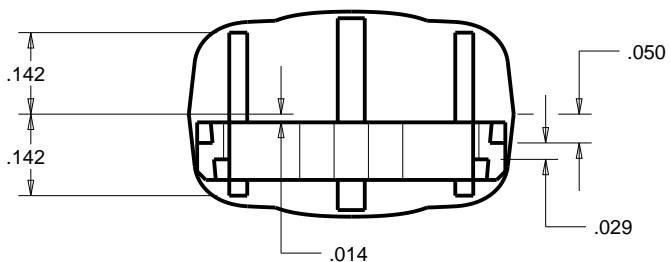
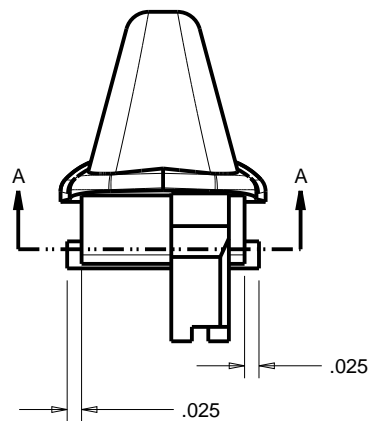
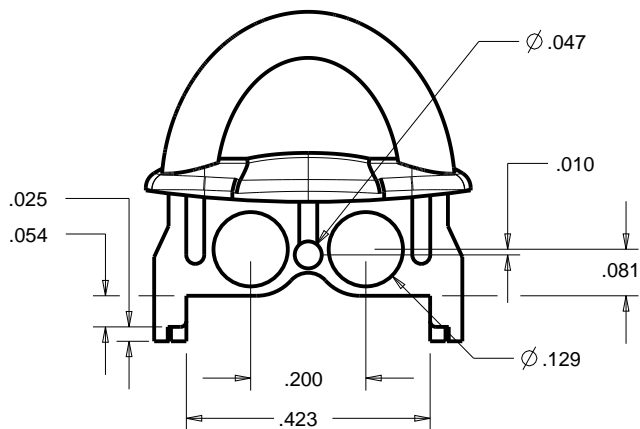
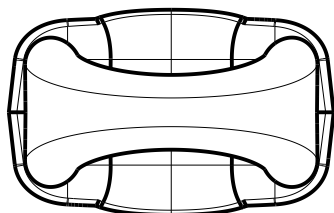

USE  $\phi .141$  CORE PIN

SECTION A-A

P210603K END w/ KEYRING  
 SCALE 3.000

CRITICAL DIMENSIONS:  
 SAME AS END W/ RING

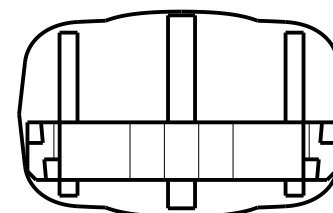
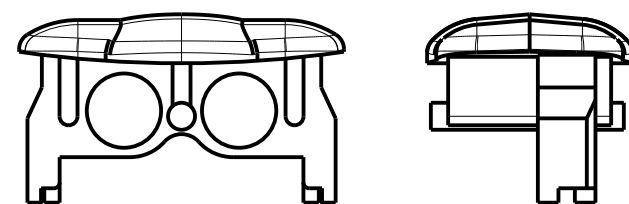

P210603L END  
 SCALE 3.000

TOLERANCES: UNLESS OTHERWISE SPECIFIED  
 DIMENSIONS ARE IN U.S. INCHES.  
 X.XX = .015 X.XXXX = .001  
 X.XXX = .010 X.X° = 1°

NEW AGE ENCLOSURES  
 Customer's Part No: 210603

APPROVAL	BY	DATE
CHECK		
ENG.		
SCALE	AS NOTED	

DRAWN BY  
 M BOYER

**NEW AGE ENCLOSURES**  
 4330 Santa Fe Road San Luis Obispo, CA. 93401  
 ph. (805) 595-1310 fax (805) 595-1024  
[www.newageenclosures.com](http://www.newageenclosures.com)

**STANDARD - USB STICK  
 PXX-210603X ASSEMBLY**

SIZE A	DRAWING NAME 210603_R10_5	SHEET 4 OF 7	REV.DOC 10.5
-----------	------------------------------	-----------------	-----------------

OPTIONAL USB CAP  
P210603C CAP

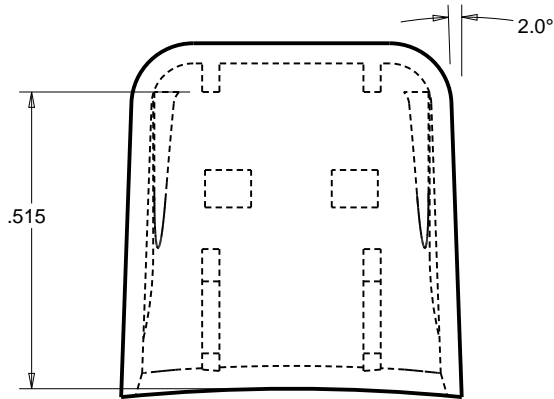
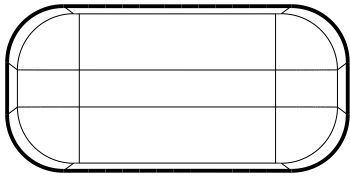

SCALE 3.000

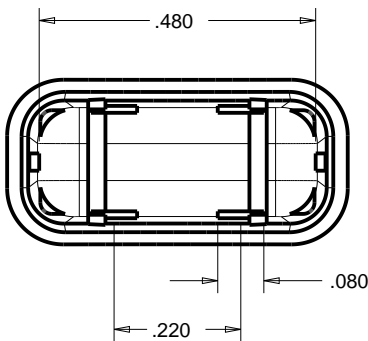

MT-11010 or EQUIV.

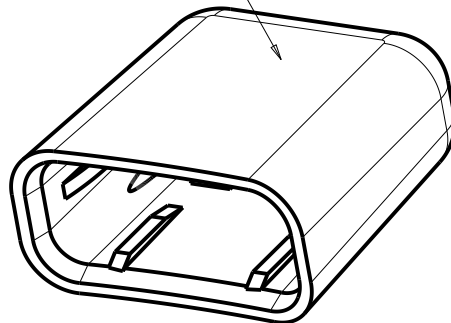

R.098

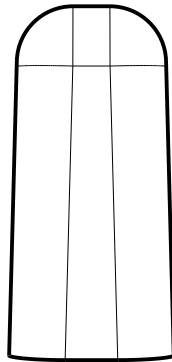

1.5°

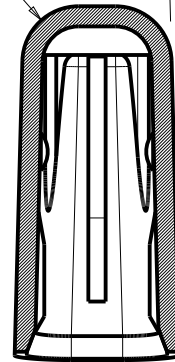

SECTION Y-Y

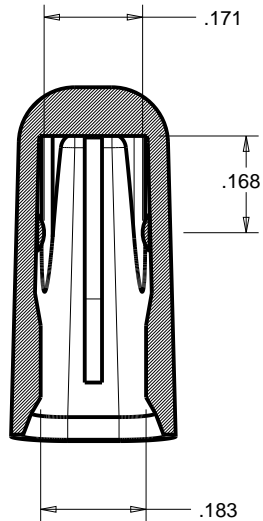

SECTION A-A

TOLERANCES: UNLESS OTHERWISE SPECIFIED  
DIMENSIONS ARE IN U.S. INCHES.

X.XX = .015 X.XXXX = .001  
X.XXX = .010 X.X° = 1°

NEW AGE ENCLOSURES

Customer's Part No: 210603

APPROVAL BY DATE

CHECK

ENG.

SCALE AS NOTED

DRAWN BY M BOYER

07-Jul-06

**NEW AGE ENCLOSURES**

4330 Santa Fe Road San Luis Obispo, CA. 93401  
ph. (805) 595-1310 fax (805) 595-1024  
[www.newageenclosures.com](http://www.newageenclosures.com)

**STANDARD - USB STICK  
PXX-210603X ASSEMBLY**

SIZE A DRAWING NAME 210603\_R10\_5

SHEET 5 OF 7 REV.DOC 10.5

# P210603 PCB - CUSTOMER SUPPLIED

PCB SIZES ARE RECOMMENDATIONS ONLY. FINAL SIZES AND VERIFICATION OF IT'S FIT ARE THE SOLE RESPONSIBILITY OF THE OEM.

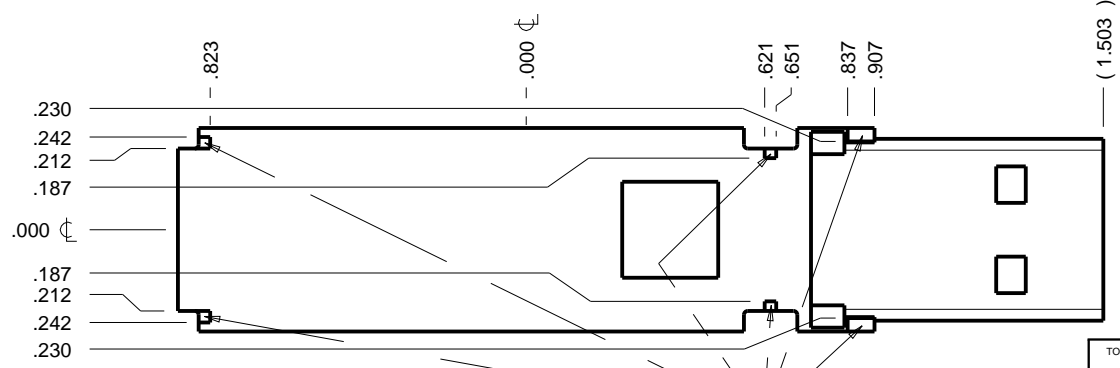
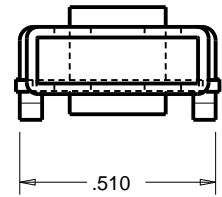
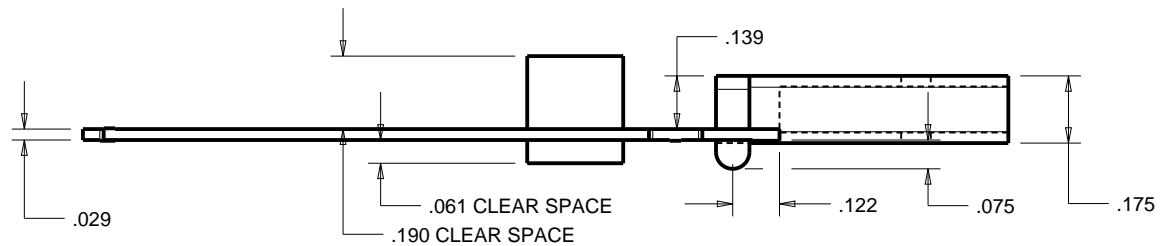
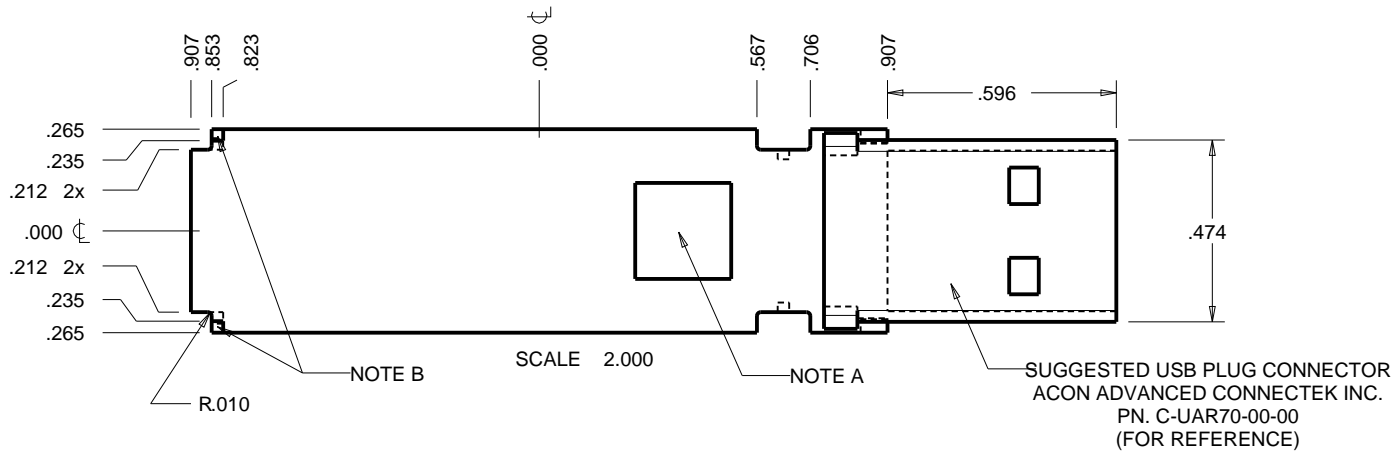

- NOTE
- A. FICTITIOUS COMPONENT SHOWN TO REPRESENT VERTICLE SPACE AVAILABLE.
  - B. KEEP OUT ZONES REPRESENT AREAS WHERE THE PLASTIC ENCLOSURE WILL CONTACT THE PCB.
  - C. SOLID MODELS (STP) ARE AVAILABLE FOR DOWNLOAD. OTHER FORMATS ARE AVAILABLE UPON REQUEST.

TOLERANCES: UNLESS OTHERWISE SPECIFIED DIMENSIONS ARE IN U.S. INCHES.	
X.XX = .015	X.XXXX = .001
X.XXX = .010	X.X° = 1°
NEW AGE ENCLOSURES	
Customer's Part No: 210603	
APPROVAL	BY DATE
CHECK	
ENG.	
SCALE	AS NOTED
DRAWN BY	07-Jul-06
M BOYER	

**NEW AGE ENCLOSURES**  
 4330 Santa Fe Road San Luis Obispo, CA. 93401  
 ph. (805) 595-1310 fax (805) 595-1024  
[www.newageenclosures.com](http://www.newageenclosures.com)

**STANDARD - USB STICK PXX-210603X ASSEMBLY**

SIZE	DRAWING NAME	SHEET	REV.DOC
A	210603_R10_5	6 OF 7	10.5



## 2nd OPERATION DETAILS

NEW AGE ENCLOSURES DELIVERS YOUR ENCLOSURE MARKET-READY WITH IN-HOUSE  
CNC MACHINING, PAD PRINTING, ASSEMBLY, AND FULFILLEMENT.  
ALL SURFACES AND AREAS ARE AVAILABLE FOR CNC ALTERATION BY NEW AGE ENCLOSURES  
CALL (805) 595-1310 FOR PRICING AND SCHEDULE.  
THE INSIDE RADIUS OF ANY MACHINED FEATURES SHOULD BE NO SMALLER THAN .031"

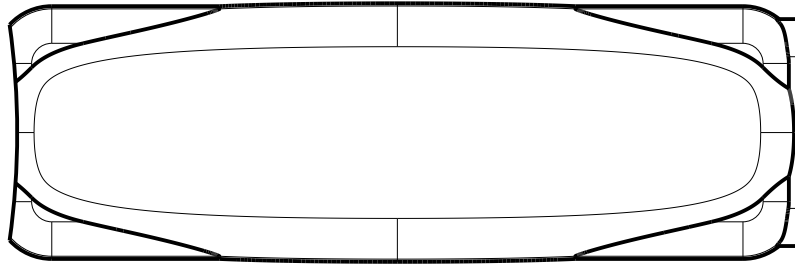

SCALE 2.000

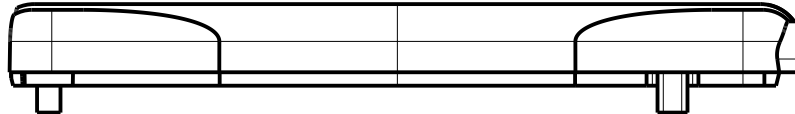

### PXX-210603X-XXX COVER - ABS, BLACK

STEP NO	DESCRIPTION	CUTTER	FIXTURE	ORIENTATION	PROGRAM
1	-	T2 = .062" EM	-	-	-
2	-	T2 = .062" EM	-	-	-
3	-	T2 = .062" EM	-	-	-

TOLERANCES: UNLESS OTHERWISE SPECIFIED DIMENSIONS ARE IN U.S. INCHES. X.XX = .015 X.XXXX = .001 X.XXX = .010 X.X° = 1°			<b>NEW AGE ENCLOSURES</b>		<b>NEW AGE ENCLOSURES</b> 4330 Santa Fe Road San Luis Obispo, CA. 93401 ph. (805) 595-1310 fax (805) 595-1024 <a href="http://www.newageenclosures.com">www.newageenclosures.com</a>	
Customer's Part No: 210603			STANDARD - USB STICK PXX-210603X ASSEMBLY			
APPROVAL	BY	DATE	SIZE	DRAWING NAME		SHEET
CHECK			A	210603_R10_5	7 OF 7	10.5
ENG.			SCALE AS NOTED			
DRAWN BY			07-Jul-06			
M BOYER						

# Mouser Electronics

Authorized Distributor

Click to View Pricing, Inventory, Delivery & Lifecycle Information:

## New Age Enclosures:

[3A-210603C](#) [1A-210603C](#) [P1A-210603L](#) [P1A-210603K](#) [P3A-210603L](#) [P3A-210603K](#) [0P-210603C](#)

Компания «Life Electronics» занимается поставками электронных компонентов импортного и отечественного производства от производителей и со складов крупных дистрибьюторов Европы, Америки и Азии.

С конца 2013 года компания активно расширяет линейку поставок компонентов по направлению коаксиальный кабель, кварцевые генераторы и конденсаторы (керамические, пленочные, электролитические), за счёт заключения дистрибьюторских договоров

Мы предлагаем:

- Конкурентоспособные цены и скидки постоянным клиентам.
- Специальные условия для постоянных клиентов.
- Подбор аналогов.
- Поставку компонентов в любых объемах, удовлетворяющих вашим потребностям.
- Приемлемые сроки поставки, возможна ускоренная поставка.
- Доставку товара в любую точку России и стран СНГ.
- Комплексную поставку.
- Работу по проектам и поставку образцов.
- Формирование склада под заказчика.
- Сертификаты соответствия на поставляемую продукцию (по желанию клиента).
- Тестирование поставляемой продукции.
- Поставку компонентов, требующих военную и космическую приемку.
- Входной контроль качества.
- Наличие сертификата ISO.

В составе нашей компании организован Конструкторский отдел, призванный помогать разработчикам, и инженерам.

Конструкторский отдел помогает осуществить:

- Регистрацию проекта у производителя компонентов.
- Техническую поддержку проекта.
- Защиту от снятия компонента с производства.
- Оценку стоимости проекта по компонентам.
- Изготовление тестовой платы монтаж и пусконаладочные работы.



Тел: +7 (812) 336 43 04 (многоканальный)

Email: [org@lifeelectronics.ru](mailto:org@lifeelectronics.ru)