

M3-F Micro-Mechatronic Focus Modules



Precision lens control; superior image quality

M3-F focus modules add high-resolution lens motion to the smallest OEM cameras. A complete closed-loop motion solution, the M3-F module is no larger than a fixed lens holder and has low power requirements for use in battery-powered devices.

The M3-F module is a single-lens focus solution with minimal external processing requirements, making it simple and cost-effective to integrate focus into your camera system. Precise lens position control (0.5 micron resolution), best-in-class bi-directional repeatability and no hysteresis enable you to capture the sharpest images from your board-mounted camera system.

M3-F modules are designed for long life, with high-performance that is not susceptible to temperature or power variations.

Figure 1:
Features and Applications

Features	Applications
<ul style="list-style-type: none"> • Small: complete, compact system with NO external control board • Superior image quality: no liquid medium, NONE of the attendant issues with transmission, clarity and temperature sensitivity • Low Voltage, low power use: runs on 3.3 V input, holds focus with power off • Simple system integration: accepts high-level commands over standard serial interface (I2C or SPI) • Flexible, production-ready system: compatible with M8 to M12 lenses and standard imager formats (e.g. 1/2" and 1/1.8") • Cost-effective system solution: single-lens system with embedded closed-loop drive circuit for high repeatability with low external processing requirements 	<p><i>Miniature, high-resolution cameras</i></p> <ul style="list-style-type: none"> • Biometric systems • Infrared cameras • Medical • diagnostic and inspection systems • Machine vision • and industrial inspection systems • Conferencing systems • Miniature surveillance cameras, video cameras, computer cameras • Projectors • Targeting systems

The M3 micro-mechatronic platform

The M3-F module is built on New Scale's M3 Micro-Mechatronic Module technology platform. The platform provides the smallest, highest resolution and most repeatable closed-loop micro-mechatronic system available – all in an easily integrated, customizable package. The platform includes a patented SQUIGGLE[®] RV piezo micro motor, an NSD-2101 drive ASIC, an NSE-5310 high-resolution magnetic position sensor, and a microprocessor with on-board closed loop control. These combine to create the world's smallest closed-loop linear motion system, with performance comparable to much larger systems.

Flexibility and Precision: M3-F modules are easily integrated with your camera board and lens. The M3-F is a complete, drop-in focus solution that requires no more space than a fixed lens holder.

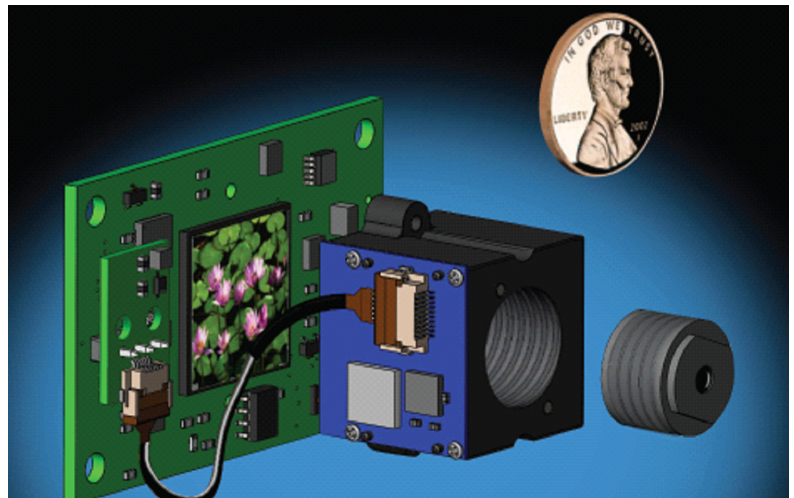

SQUIGGLE RV motor and driver inside every M3-F module is the world's smallest linear motor system.

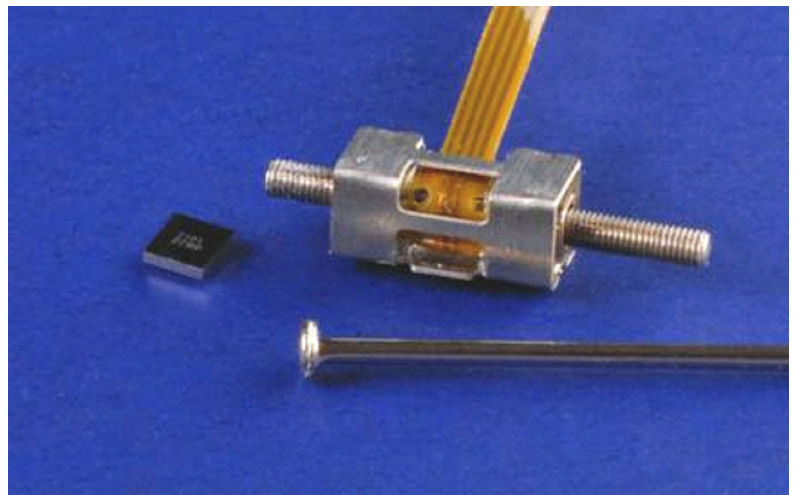

Figure 2:

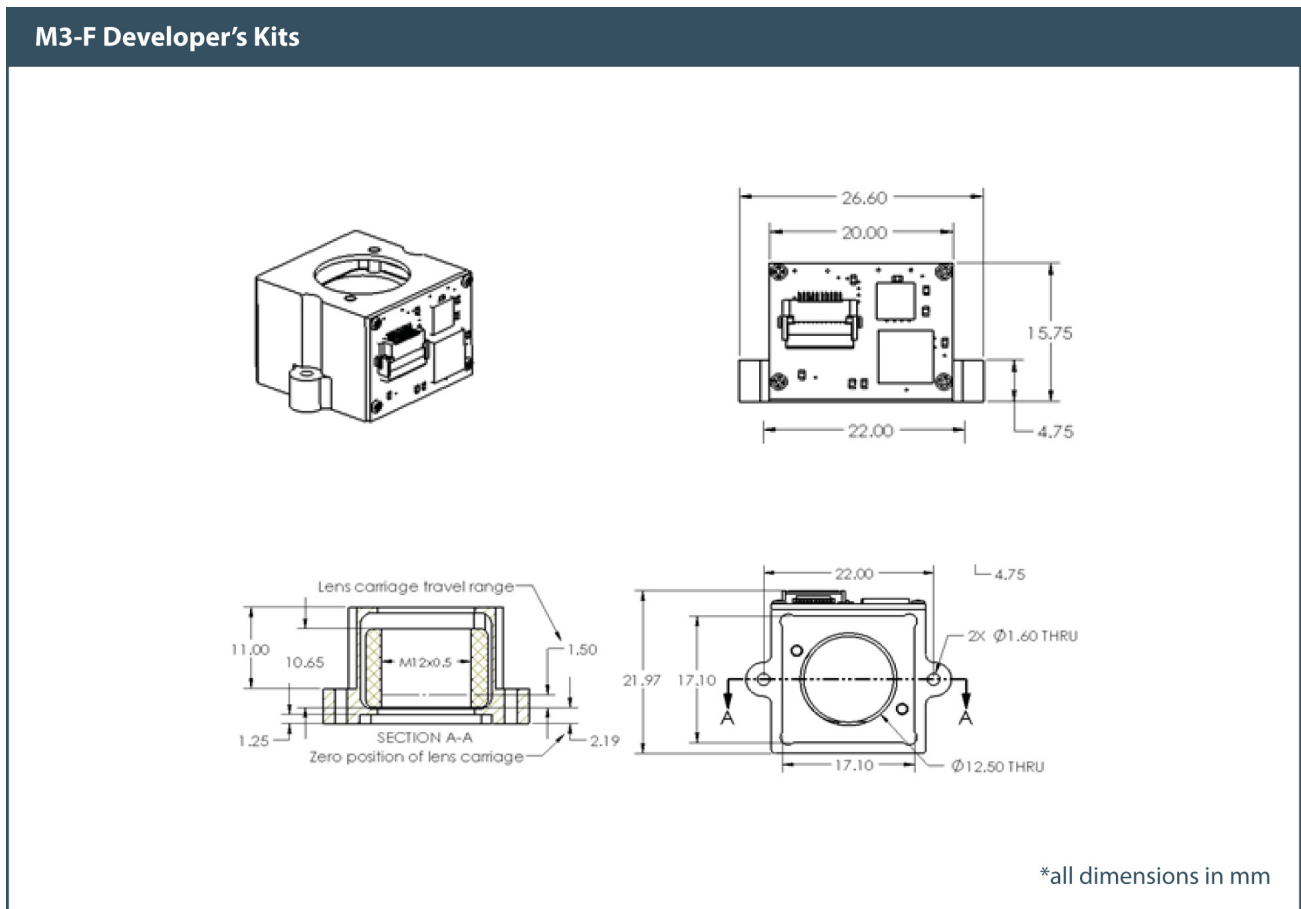

Figure 3:
M3_F Module Specifications

M3-F Module Specifications	
Lens Type (Lens not included)	Accepts M12x0.5mm smaller lenses to M8x0.35 with adapter from your lens supplier
Lens Weight *	< 5 grams
Travel Range	Up to 1.5 mm
Housing Dimension	20 x 22 x 16 mm
Max Image Sensor Area (image sensor not included)	17 x 17 x 1.25 mm (including 1/2" and 1/1.8" formats)
Speed	> 5 mm/s
Resolution	0.5 μ m
Hysteresis	None
Repeatability	Uni-directional: +/- 5 μ m Bi-directional: +/- 20 μ m
Linear Accuracy	\pm 30 μ m

Figure 3:
M3_F Module Specifications

M3-F Module Specifications	
Angular alignment (Static tip/tilt)	<± 1 degree
Angular movement (Dynamic tip/tilt)	<± 0.15 degrees
Static Concentricity	<± 0.25 mm
Dynamic Concentricity	<± 0.02 mm
Input Voltage	3.1 to 3.6 Volts
Input Power **	< 0.5 Watts (5mm/s with 5g mass) < 0.13 Watts quiescent
Temperature /RH ***	5° to 70°C (lower possible) <70% RH non-condensing
Mean Time Before Failure	>2M Cycles (fixed orientation) 500K Cycles (random orientation)
Digital Interface	I ² C or SPI
Weight of module (without lens)	5.8 grams
Compliance	CE / RoHS

* Fixed orientation will allow for heavier lens operation

** Power depends on input voltage, speed & load.

*** Consult the factory for lower temperature requirements.

Plug-and-Play New Scale Pathway Software and Flex Cable (Detachable)



Reference Information

See www.newscaletech.com/application_notes.html

- *Checking Optical and Imager Geometry in DK-M3-F* (design note). Lens recommendations, guidelines for image sensor and lens compatibility with the M3-F Developer's Kit module.
- *M3-F focus module in camera system design* (application note). Includes module details as well as repeatability and other performance considerations.

Order a Developer's Kit

Order online from Digi-Key at

<http://www.digikey.com/product-detail/en/DK-M3F-1.8-TRK-1.5-S/DK-M3F-1.8-TRK-1.5-S-ND/2563770>.

Figure 4:
Model Number and Description

Model Number	Description
DK-M3F-1.8-TRK-1.5-S	M3-F Developer's Kit including M3-F module, USB adapter (SPI), connecting cable and New Scale Pathway software.

Application-Specific Solutions

ams/New Scale can quickly create a customized focus module to meet your more exact OEM specifications including longer travel, custom lens interface, mounting requirements and unique environmental considerations. Use the custom specification worksheet at http://www.newscaletech.com/contact_AF-RFP.aspx

Компания «Life Electronics» занимается поставками электронных компонентов импортного и отечественного производства от производителей и со складов крупных дистрибьюторов Европы, Америки и Азии.

С конца 2013 года компания активно расширяет линейку поставок компонентов по направлению коаксиальный кабель, кварцевые генераторы и конденсаторы (керамические, пленочные, электролитические), за счёт заключения дистрибьюторских договоров

Мы предлагаем:

- Конкурентоспособные цены и скидки постоянным клиентам.
- Специальные условия для постоянных клиентов.
- Подбор аналогов.
- Поставку компонентов в любых объемах, удовлетворяющих вашим потребностям.
- Приемлемые сроки поставки, возможна ускоренная поставка.
- Доставку товара в любую точку России и стран СНГ.
- Комплексную поставку.
- Работу по проектам и поставку образцов.
- Формирование склада под заказчика.
- Сертификаты соответствия на поставляемую продукцию (по желанию клиента).
- Тестирование поставляемой продукции.
- Поставку компонентов, требующих военную и космическую приемку.
- Входной контроль качества.
- Наличие сертификата ISO.

В составе нашей компании организован Конструкторский отдел, призванный помогать разработчикам, и инженерам.

Конструкторский отдел помогает осуществить:

- Регистрацию проекта у производителя компонентов.
- Техническую поддержку проекта.
- Защиту от снятия компонента с производства.
- Оценку стоимости проекта по компонентам.
- Изготовление тестовой платы монтаж и пусконаладочные работы.



Тел: +7 (812) 336 43 04 (многоканальный)

Email: org@lifeelectronics.ru