

Variable Transformers
Series 1200 • 5.0 to 12.0 Amperes

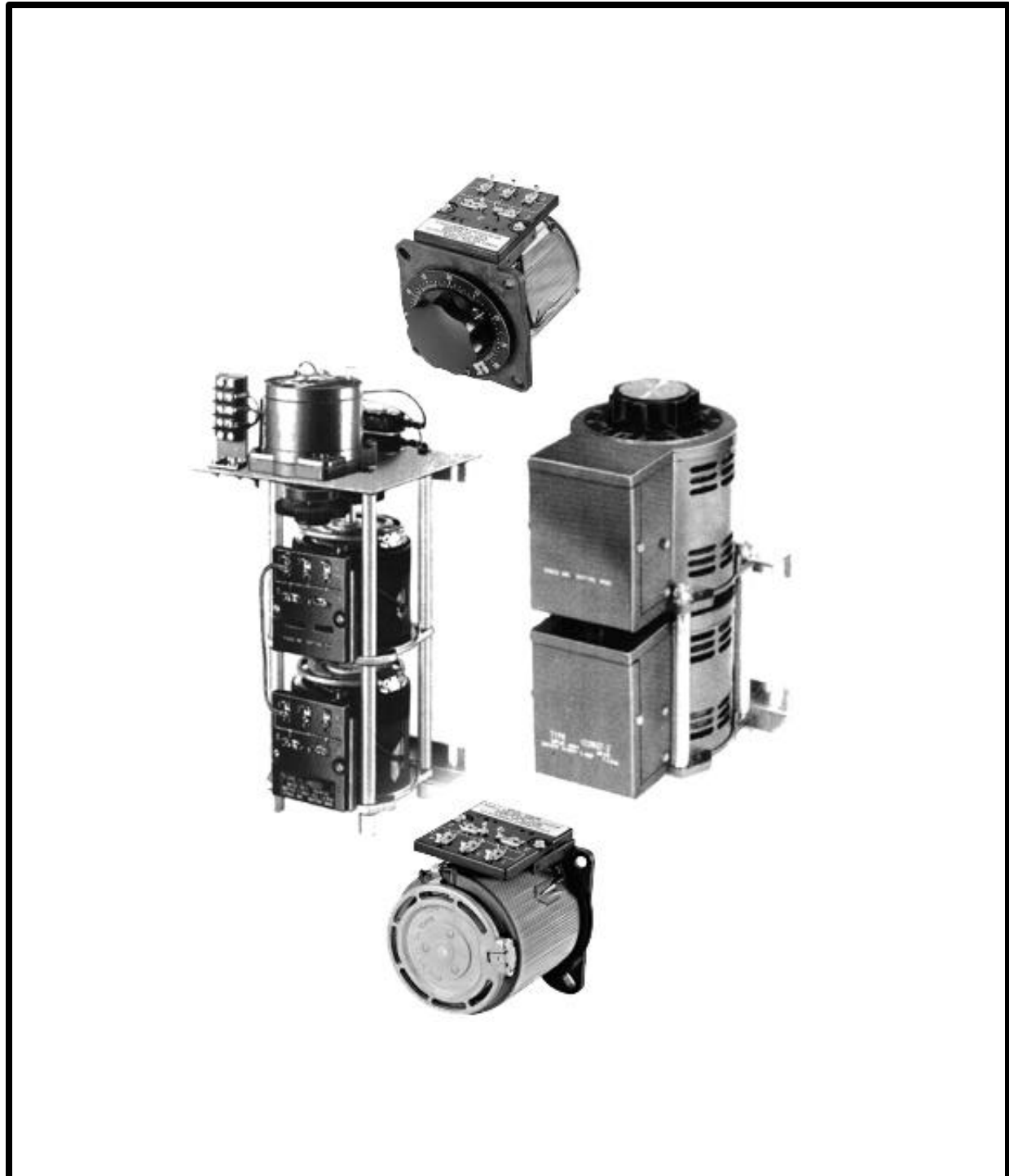

1000/1200 Series

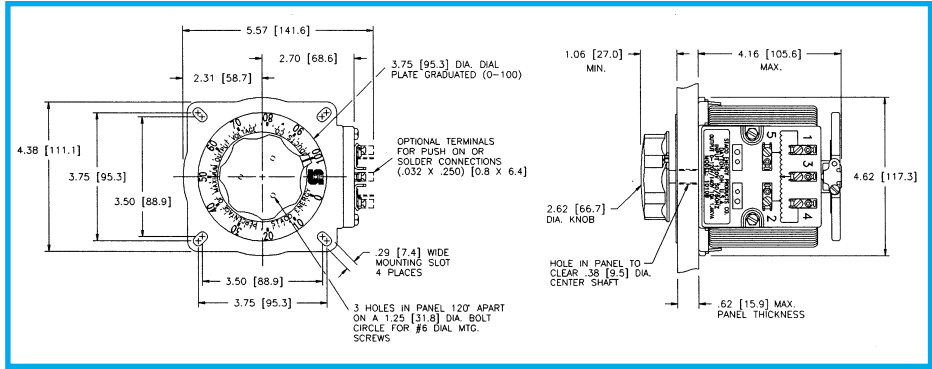
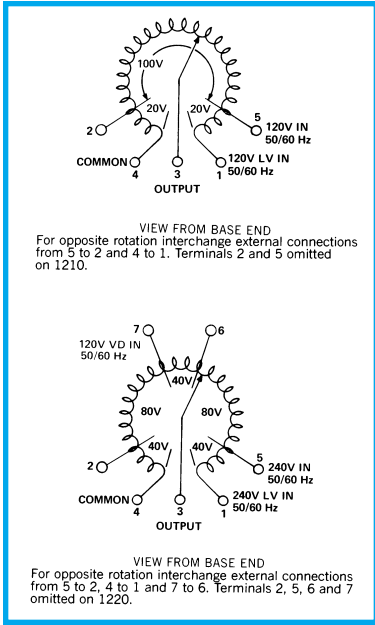

Single Unit, Uncased

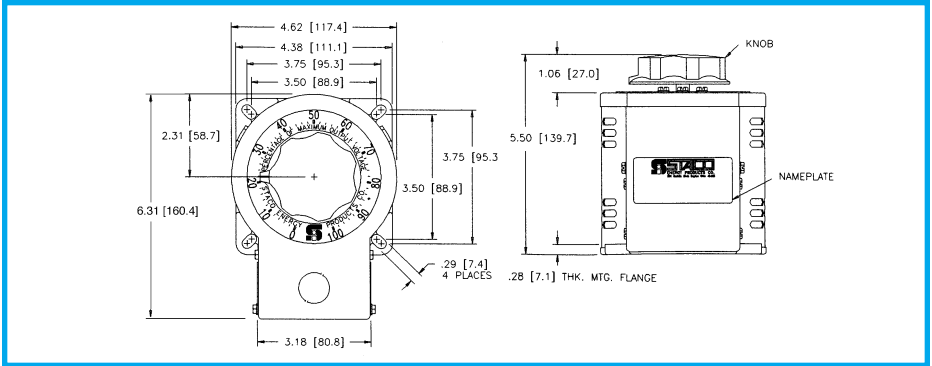

Single Unit, Cased



1010B

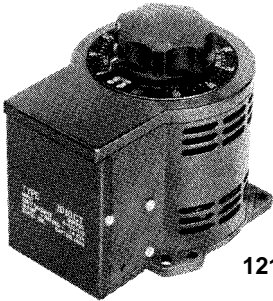

1210BCT

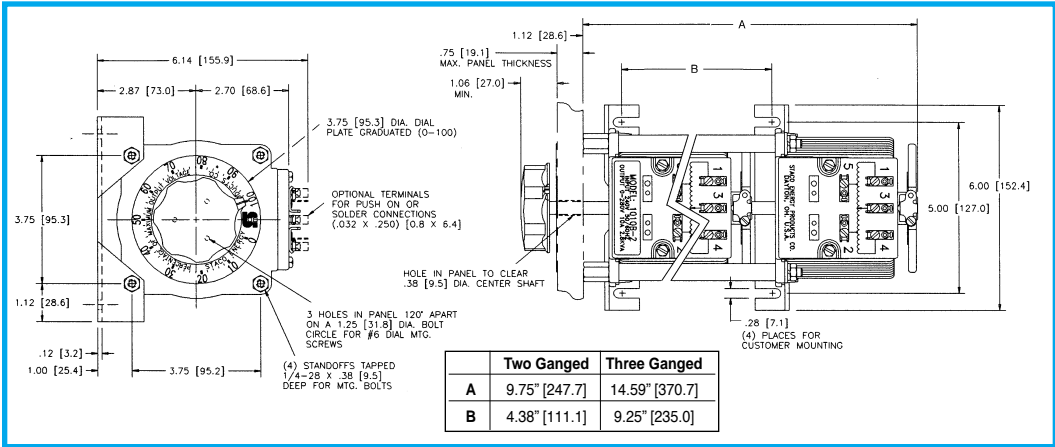

Two and Three Ganged, Uncased

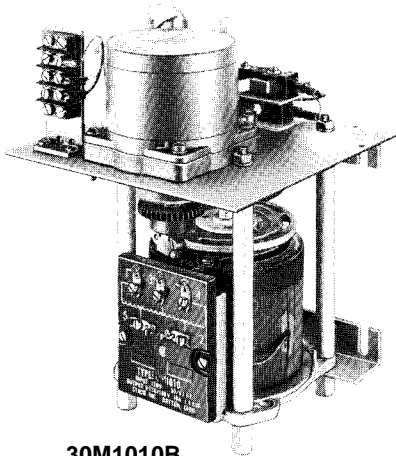

30M1010B

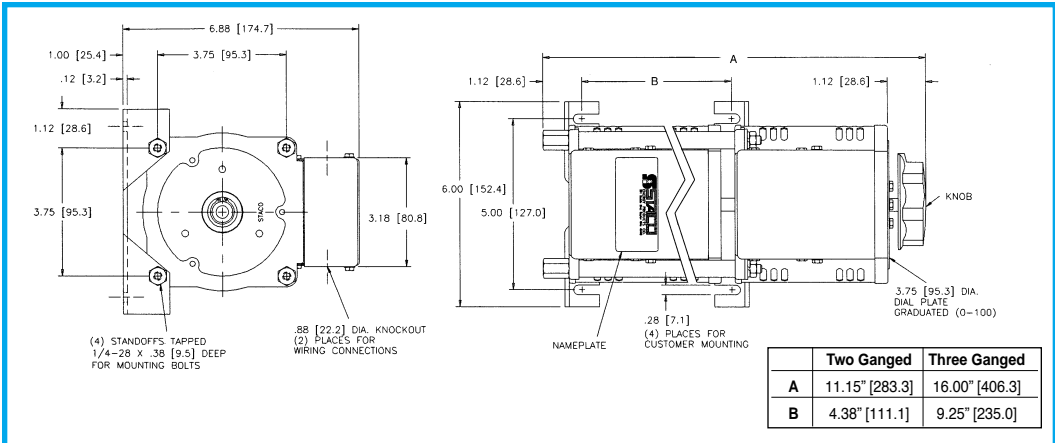

Two and Three Ganged, Cased

1000/1200 Series

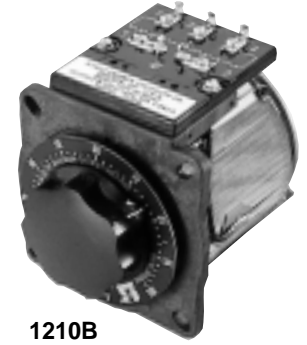
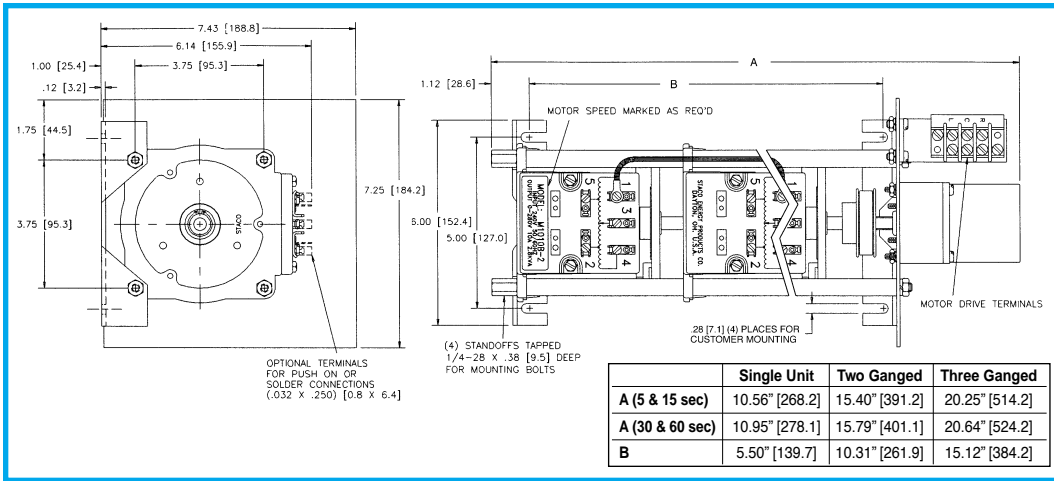

1210B
Front View

Motorized Single, Two and Three Ganged, Uncased

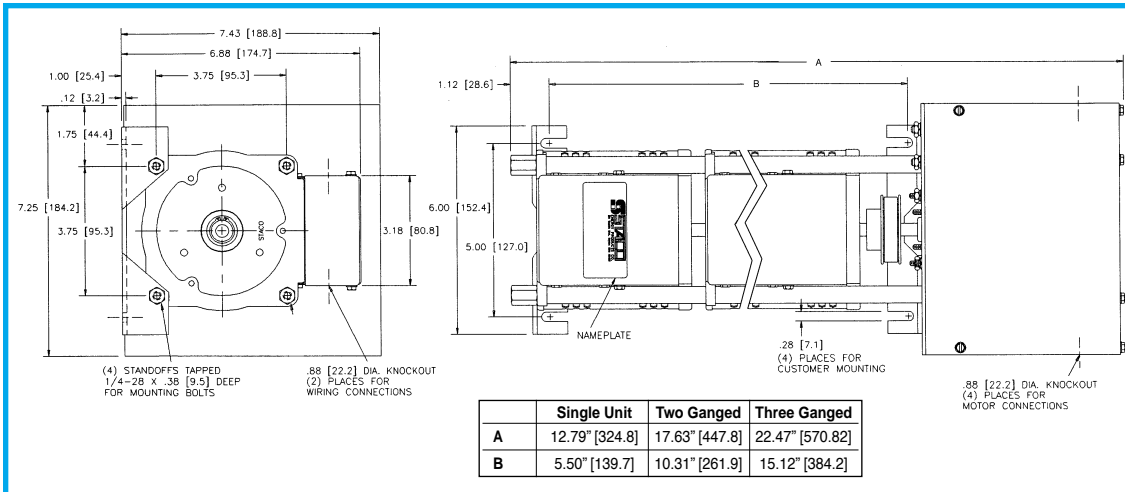

1210B
Rear View

Motorized Single, Two and Three Ganged, Cased

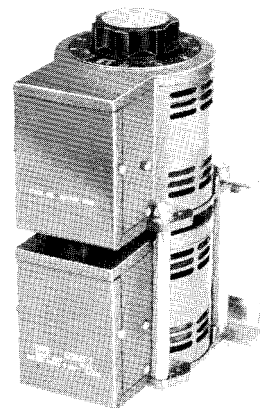

1220BCT-2

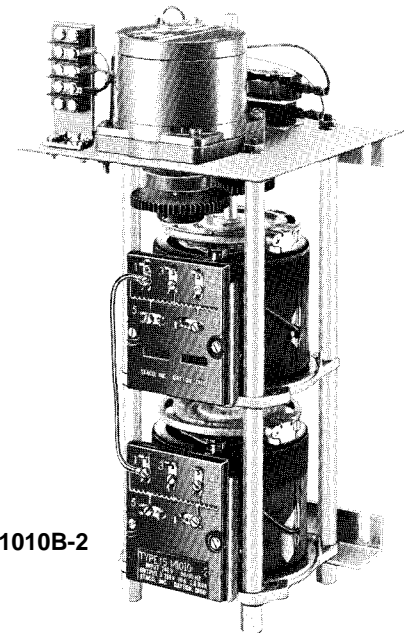

15M1010B-2

1200 Series

The 1210B operates on 120 volts and is rated for constant current of 12 amperes. The 1220B operates on 240 volts and constant current of 5 amperes. The 1210B and 1220B operate from 0 to line voltage only. There is no reduction in allowable output current up to 1500 hertz.

Uncased models have the shaft extending from the base end. This shaft is fully adjustable and can be extended from either end for general utility mounting. Cased styles, which have a "CT" suffix, feature the protective screening over the coil assembly and a terminal box cover with knock-outs to

accept conduit.

Motor driven units are available in single, two and three ganged assemblies; cased or uncased styles as identified by the prefix "M" in the type number. If a motor driven model is ordered, be sure to prefix the part number with the desired travel time from 0 to maximum of 5, 15, 30, or 60 seconds.

The synchronous motor is designed for operation on 120 volts, 50/60 hertz single phase lines and draws approximately 0.3 amperes.

| PART NO. | WIRING | INPUT | | OUTPUT | | | | SHAFT ROTATION FOR VOLTAGE INCREASE | TERMINAL CONNECTIONS (For increasing Voltage) As Viewed from Base End | | | SCHE-MATIC (Pg 8 & 9) | NET WT. LBS. | (Max) MOTOR DRIVEN | |
|--------------------------------------------------|--------------------------|-------|-------|--------|-----------------------|---------|-------------------------|-------------------------------------|-----------------------------------------------------------------------|------------------------|--------|-----------------------|--------------|--------------------|---------|
| | | VOLTS | HERTZ | VOLTS | CONSTANT CURRENT LOAD | | CONSTANT IMPEDANCE LOAD | | Input | Jumper* | Output | | | | |
| | | | | | MAX AMPS | MAX KVA | MAX AMPS | | | | | | | | MAX KVA |
| 1210B 1210BCT M1210B† M1210BCT† | Single Phase | 120 | 60 | 0-120 | 12 | 1.44 | 15 | 1.80 | CW | 1-4 | — | 4-3 | 13 | 10 1/4 | 16 3/4 |
| | | | | | | | | | CCW | 1-4 | — | 1-3 | | | |
| 1210B-2 1210BCT-2 M1210B-2† M1210BCT-2† | Single Phase Series | 240 | 60 | 0-240 | 12 | 2.88 | 15 | 3.60 | CW | 1-1 | 4-4 | 3-3 | 13 & 4 | 22 1/2 | 30 3/4 |
| | | | | | | | | | CCW | 4-4 | 1-1 | 3-3 | | | |
| | Three Phase Open Delta π | 120++ | 60 | 0-120 | 12 | 2.49 | 15 | 3.12 | CW | 1-4-1 | 4-4 | 3-4-3 | 13 & 5 | | |
| | | | | | | | | | CCW | 4-1-4 | 1-1 | 3-1-3 | | | |
| 1210B-3 1210BCT-3 M1210B-3† M1210BCT-3† | Three Phase Wye π | 240++ | 60 | 0-240 | 12 | 4.96 | 15 | 6.24 | CW | 1-1-1 | 4-4-4 | 3-3-3 | 13 & 6 | 34 1/2 | 42 1/4 |
| | | | | | | | | | CCW | 4-4-4 | 1-1-1 | 3-3-3 | | | |
| 3PN1210B | Single Phase | 120 | 60 | 0-120 | 12‡ | 1.44 | 15 | 1.80 | CW | LINE CORD & RECEPTACLE | | | 11 | 10 1/4 | — |
| 1220B 1220BCT M1220B† M1220BCT† | Single Phase | 240 | 60 | 0-240 | 5.0 | 1.20 | 7.0 | 1.68 | CW | 1-4 | — | 4-3 | 13 | 10 1/4 | 16 3/4 |
| | | | | | | | | | CCW | 1-4 | — | 1-3 | | | |
| 1220B-2 1220BCT-2 M1220B-2† M1220BCT-2† | Single Phase Series | 480 | 60 | 0-480 | 5.0 | 2.40 | 7.0 | 3.36 | CW | 1-1 | 4-4 | 3-3 | 13 & 4 | 22 1/2 | 30 3/4 |
| | | | | | | | | | CCW | 4-4 | 1-1 | 3-3 | | | |
| | Three Phase Open Delta π | 240++ | 60 | 0-240 | 5.0 | 2.08 | 7.0 | 2.91 | CW | 1-4-1 | 4-4 | 3-4-3 | 13 & 5 | | |
| | | | | | | | | | CCW | 4-1-4 | 1-1 | 3-1-3 | | | |
| 1220B-3 1220BCT-3 M1220B-3† M1220BCT-3† | Three Phase Wye π | 480++ | 60 | 0-480 | 5.0 | 4.16 | 7.0 | 5.82 | CW | 1-1-1 | 4-4-4 | 3-3-3 | 13 & 6 | 34 1/2 | 42 1/4 |
| | | | | | | | | | CCW | 4-4-4 | 1-1-1 | 3-3-3 | | | |
| 3PN1220B | Single Phase | 240 | 60 | 0-240 | 5.0‡ | 1.20 | 7.0 | 1.68 | CW | LINE CORD & RECEPTACLE | | | 11 | 10 1/4 | — |

* Jumper provided in the standard common position and should be moved or removed as required.

++ Line to line voltage

‡ Unit is fused for the constant current rating at the factory.

† Motor driven units use terminal connections for CCW increasing voltage, as viewed from the base end. See Figure 23 on page 9 for motor wiring.

π If ganged units are used in a system that ordinarily has a common neutral or ground between source and load, the neutral or ground must be connected to the common terminals of the variable transformer assembly. If the system has no neutral, the load must be balanced or the transformers will be damaged.

Maximum output current in output voltage range from 0 to 25% above line voltage. At higher output voltages, the output current must be reduced according to the derating curve, Figure B, page 6.

Компания «Life Electronics» занимается поставками электронных компонентов импортного и отечественного производства от производителей и со складов крупных дистрибьюторов Европы, Америки и Азии.

С конца 2013 года компания активно расширяет линейку поставок компонентов по направлению коаксиальный кабель, кварцевые генераторы и конденсаторы (керамические, пленочные, электролитические), за счёт заключения дистрибьюторских договоров

Мы предлагаем:

- Конкурентоспособные цены и скидки постоянным клиентам.
- Специальные условия для постоянных клиентов.
- Подбор аналогов.
- Поставку компонентов в любых объемах, удовлетворяющих вашим потребностям.
- Приемлемые сроки поставки, возможна ускоренная поставка.
- Доставку товара в любую точку России и стран СНГ.
- Комплексную поставку.
- Работу по проектам и поставку образцов.
- Формирование склада под заказчика.
- Сертификаты соответствия на поставляемую продукцию (по желанию клиента).
- Тестирование поставляемой продукции.
- Поставку компонентов, требующих военную и космическую приемку.
- Входной контроль качества.
- Наличие сертификата ISO.

В составе нашей компании организован Конструкторский отдел, призванный помогать разработчикам, и инженерам.

Конструкторский отдел помогает осуществить:

- Регистрацию проекта у производителя компонентов.
- Техническую поддержку проекта.
- Защиту от снятия компонента с производства.
- Оценку стоимости проекта по компонентам.
- Изготовление тестовой платы монтаж и пусконаладочные работы.



Тел: +7 (812) 336 43 04 (многоканальный)

Email: org@lifeelectronics.ru