

LOC	DIST	REVISIONS					
GP	00	REV	PER	DESCRIPTION	DATE	DWN	APVD
		E6	REV PER	ECR-12-013669	02AUG2012	AY	SZ

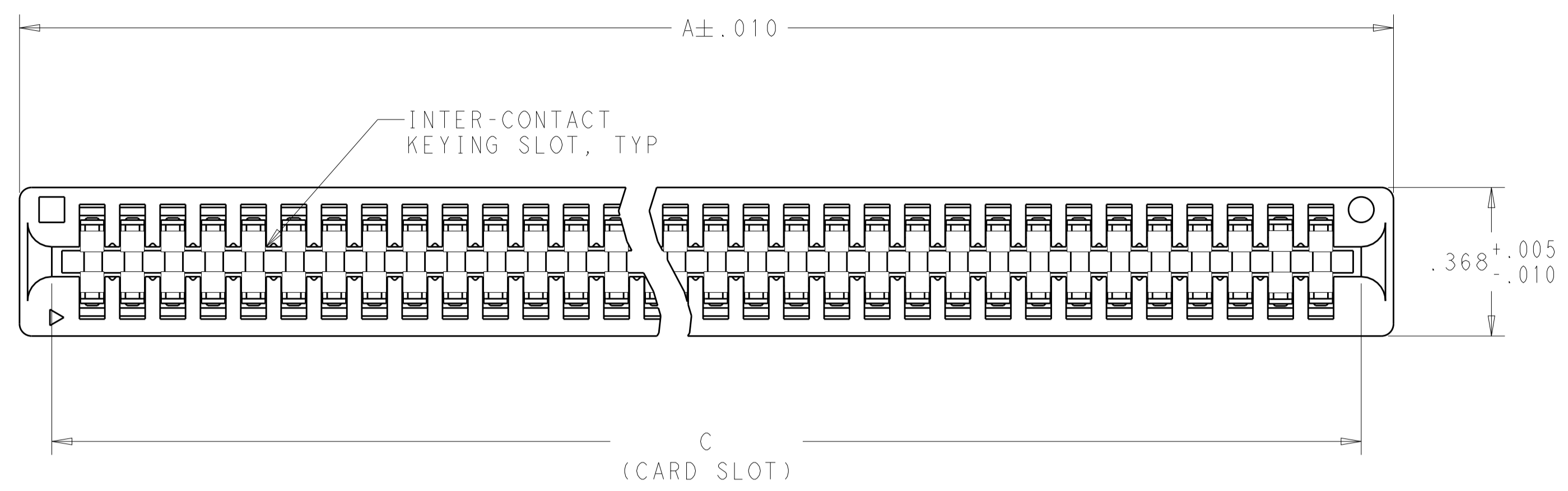

- 1 MATERIAL:
HOUSING - GLASS FILLED POLYESTER, COLOR BLACK
CONTACT - PHOSPHOR BRONZE
- 2 FINISH:
(SEE TABLE FOR GOLD PLATING) IN CONTACT AREA.
.000100 MIN MATTE TIN ON SOLDER POSTS. ALL OVER
.000050 MIN THK. NICKEL
- 3 AMP LOGO, TE PART NUMBER, DATE CODE AND CSA LOGO INK STAMPED WHITE (HOT STAMPED OR LAZER PRINTED) IN THE APPROXIMATE AREA SHOWN, EITHER SIDE PERMISSABLE WHEN HOUSING SIZE PERMITS
- 4. RECOMMENDED PCB FINISHED HOLE $\varnothing .040 \pm .003$
- 5 .000015 MIN
- 6 .000030 MIN
- 7 OBSOLETE PARTS: OBSOLETE CIS STREAMLINING PER D.RENAUD/D.SINISI

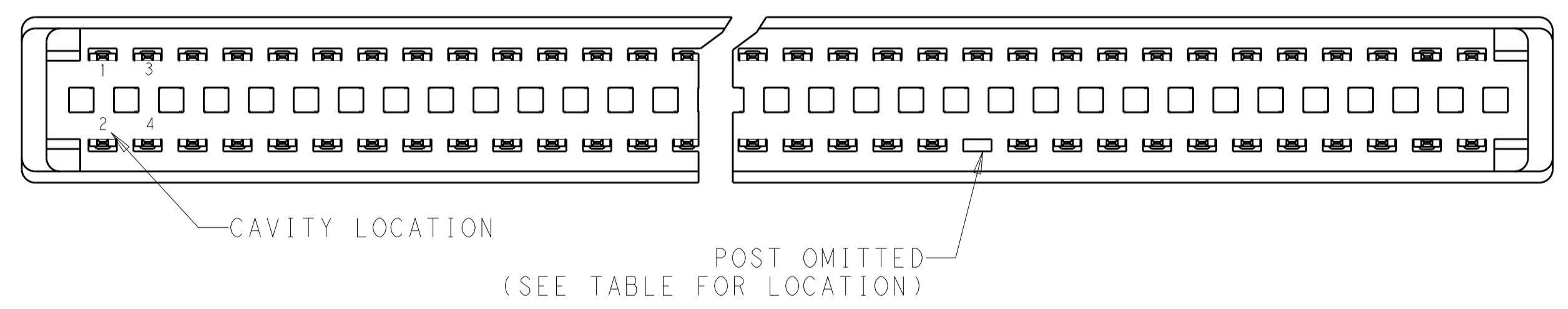
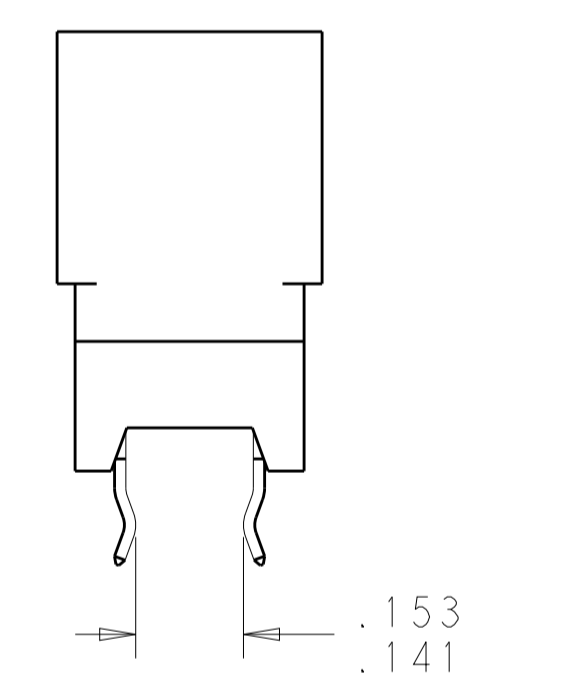
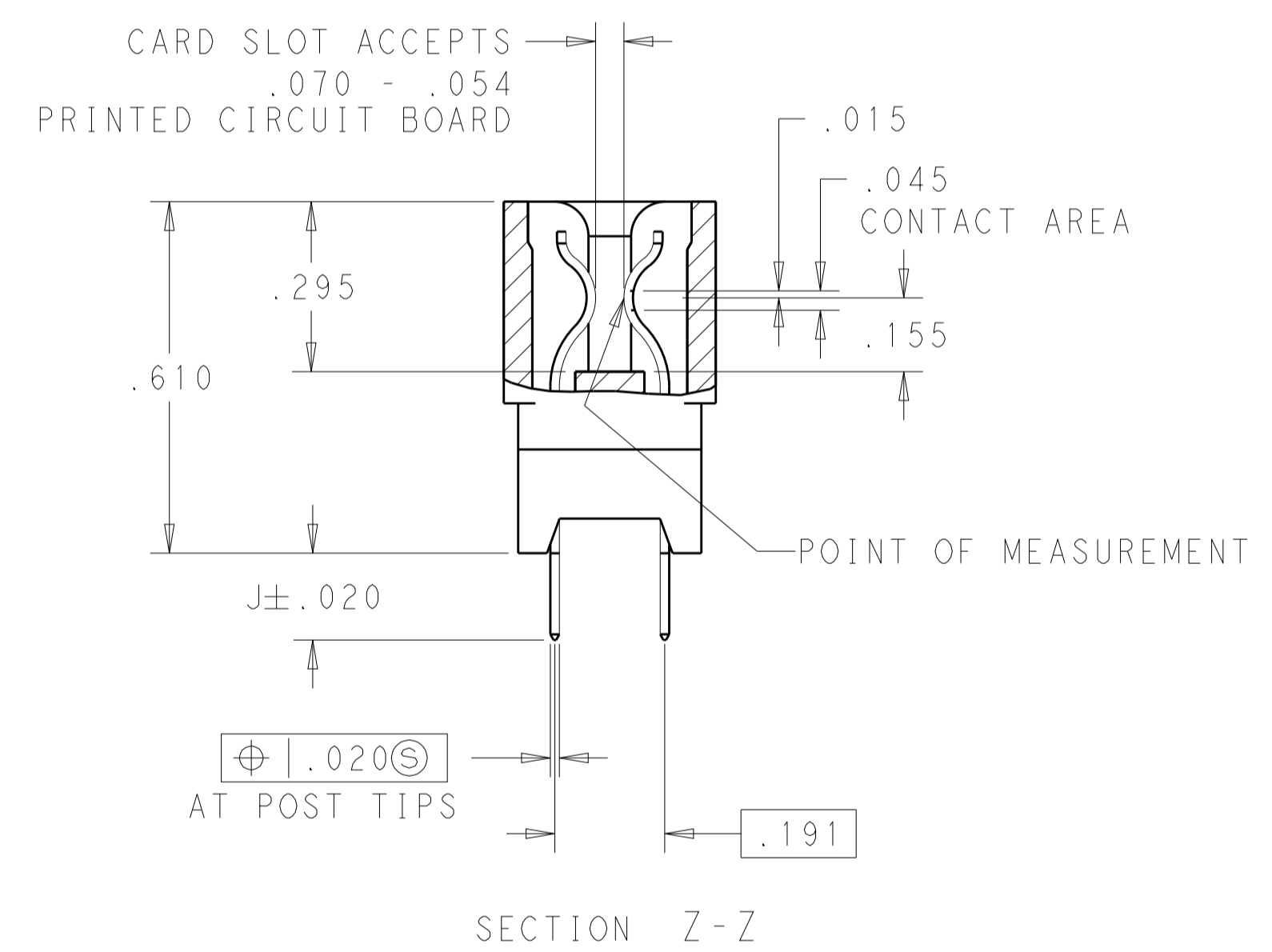
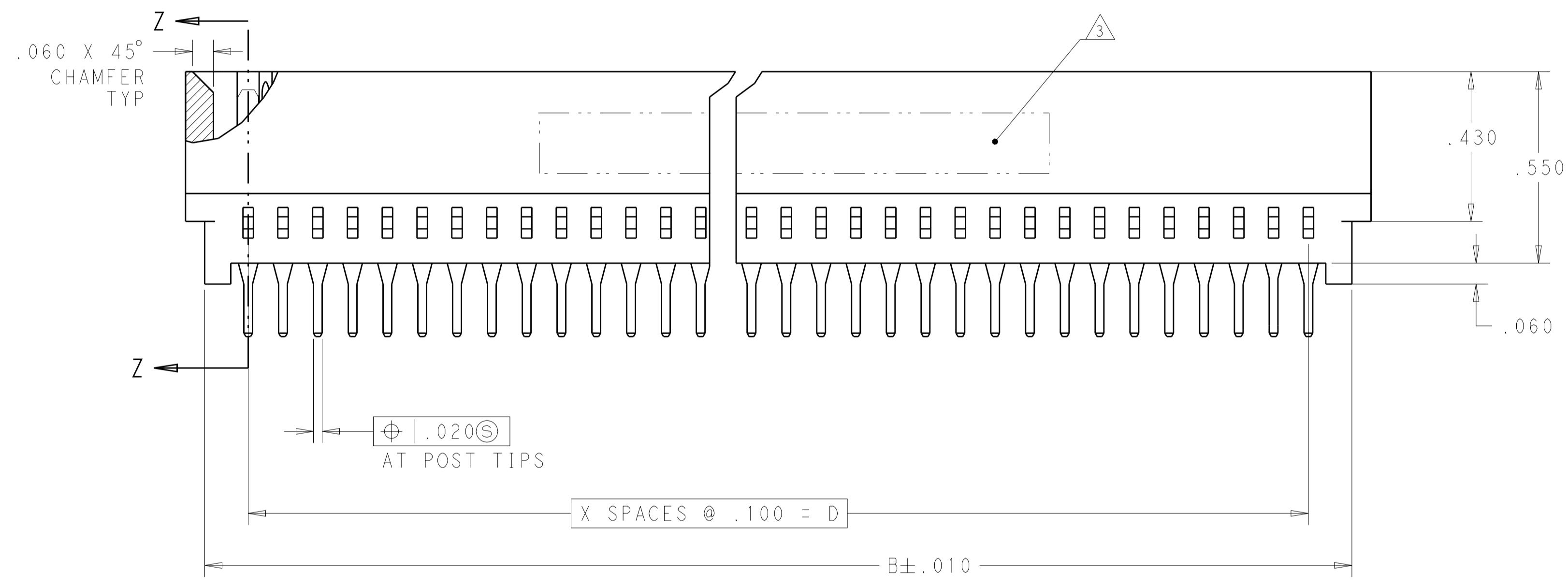

THIS DRAWING IS A CONTROLLED DOCUMENT.		DWN AWF/GRZYBOWSKI	30OCT2009	 TE Connectivity
DIMENSIONS: INCHES		CHK E.HOWARD	APVD M.PERCHEK	
TOLERANCES UNLESS OTHERWISE SPECIFIED:		PRODUCT SPEC	108-9039	NAME CONNECTOR ASSEMBLY STANDARD EDGE II, .100 CENTERLINE
0 PLC \pm 1 PLC $\pm .005$ 2 PLC \pm 3 PLC \pm 4 PLC \pm ANGLES \pm		APPLICATION SPEC	114-13018	
MATERIAL		WEIGHT	SIZE A100779	RESTRICTED TO
FINISH		CUSTOMER DRAWING	CAGE CODE DRAWING NO C=5530843	SCALE 4:1 SHEET 1 OF 4 REV E7

LOC		DIST		REVISIONS			
GP	00	P	LTN	DESCRIPTION	DATE	DWN	APVD
-	-	-	-	SEE SHEET 1	-	-	-

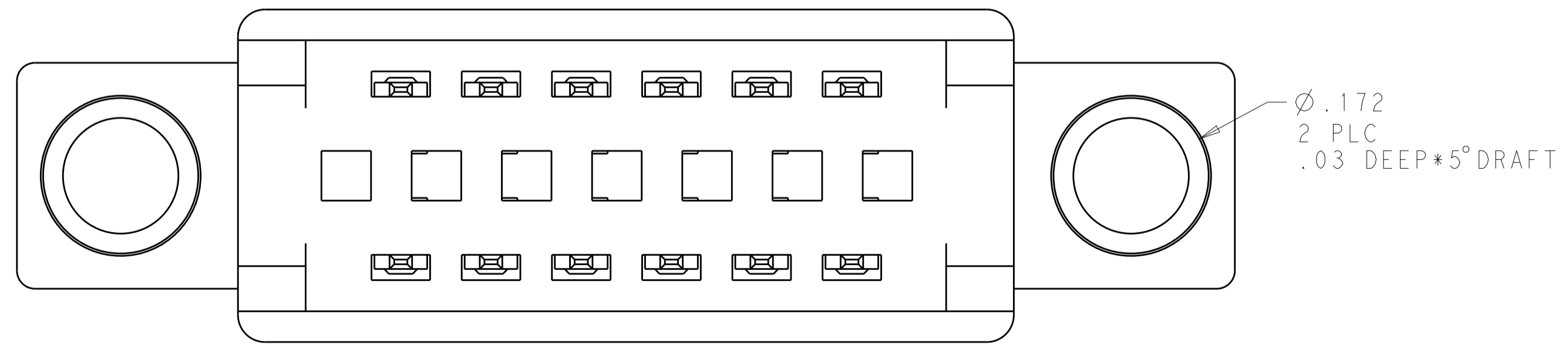
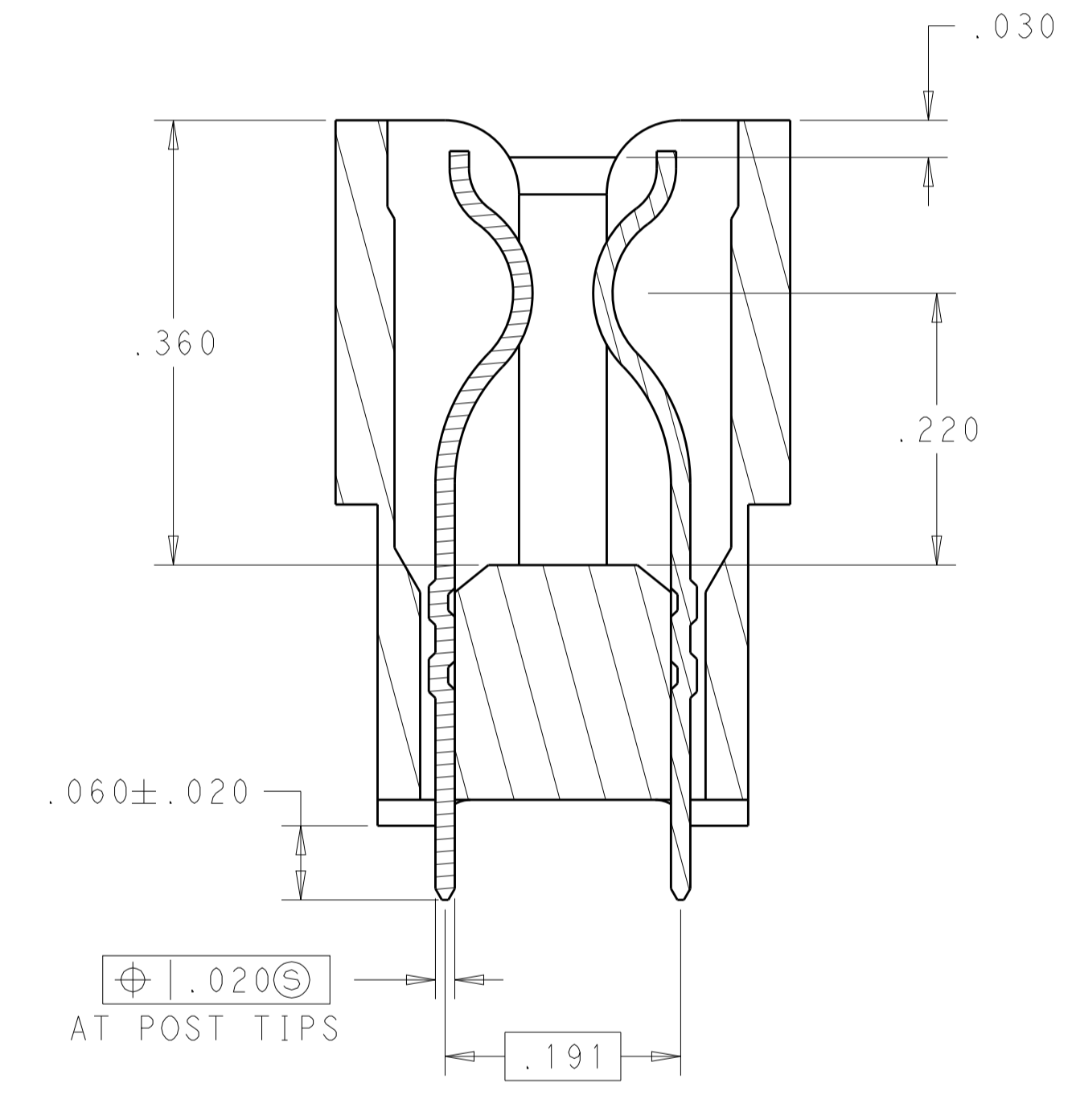
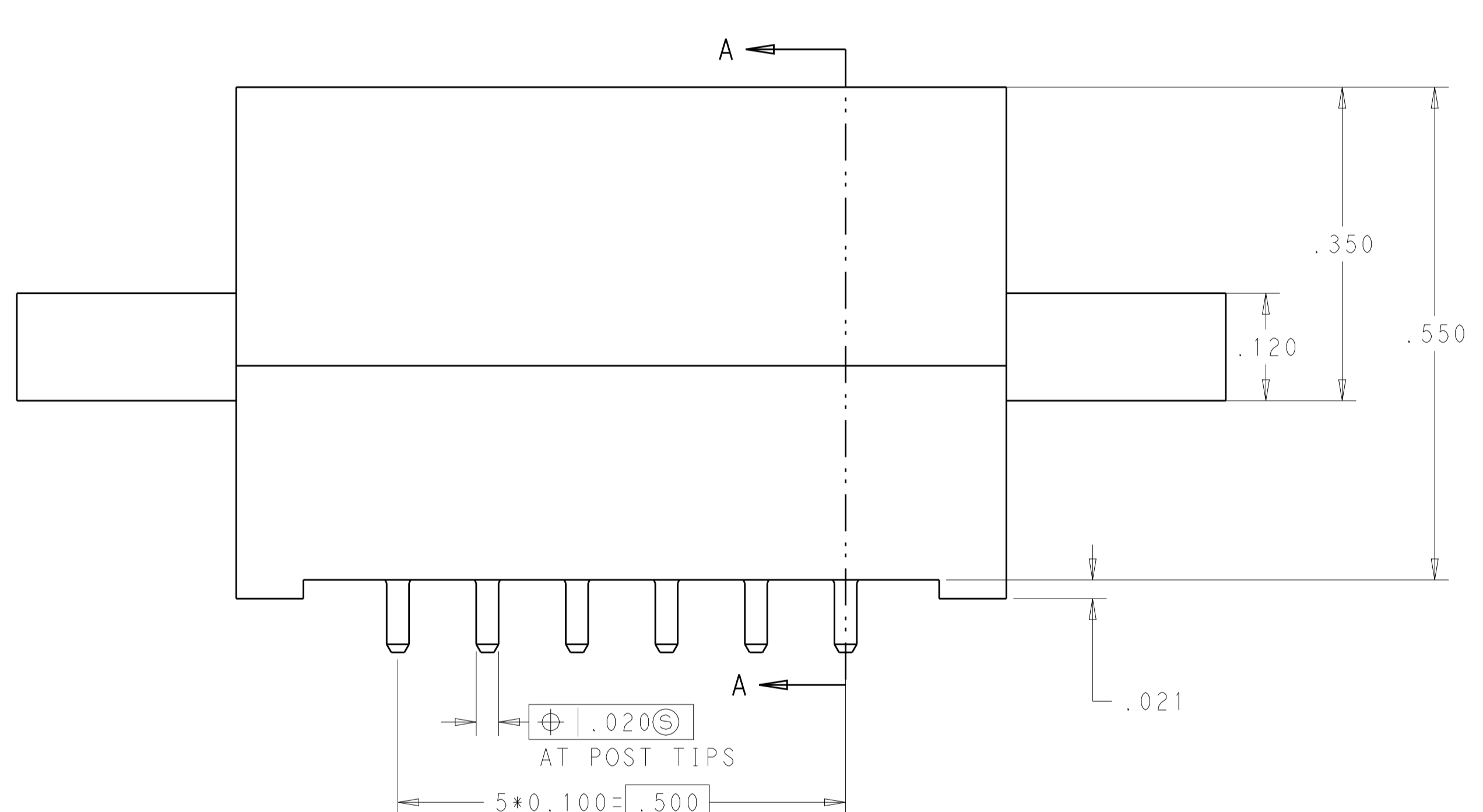
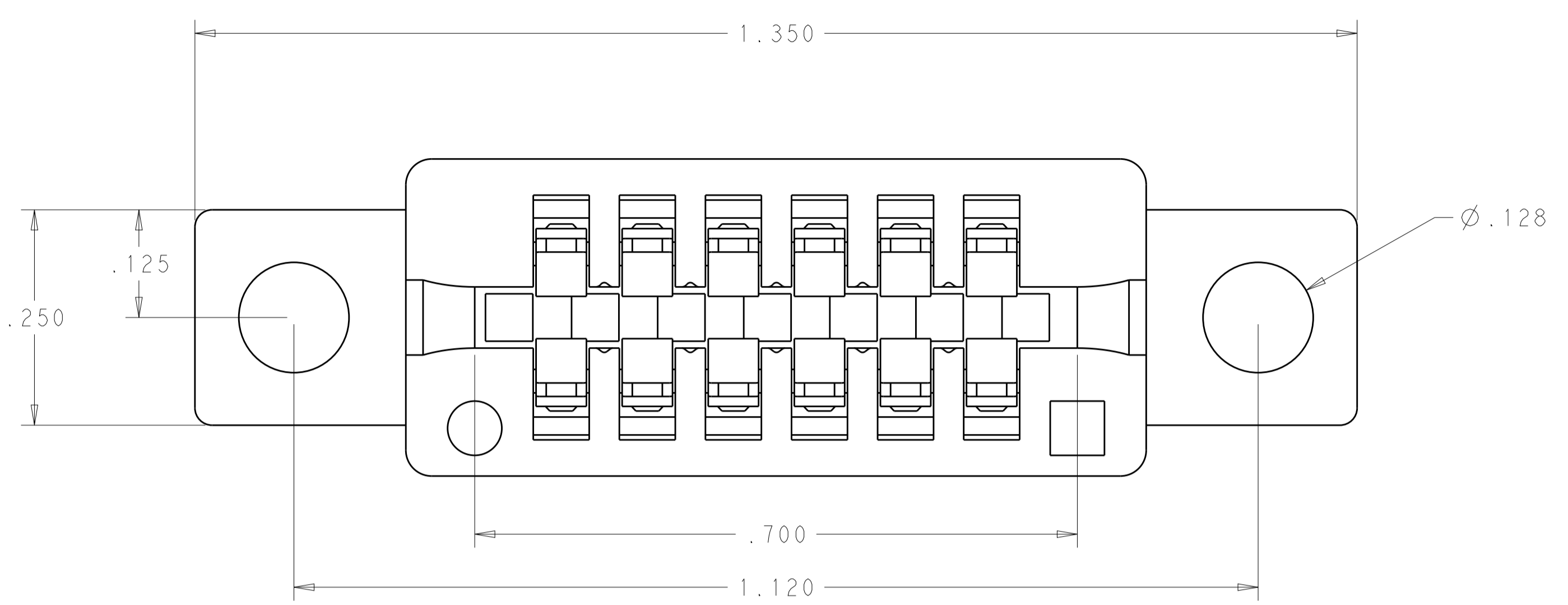

THIS DRAWING IS A CONTROLLED DOCUMENT.		DWN: AWF/GRZYBOWSKI 30OCT2009	TE Connectivity
DIMENSIONS: INCHES		CHK: E.HOWARD	
TOLERANCES UNLESS OTHERWISE SPECIFIED:		APVD: M.PERCHEK 30OCT2009	NAME: CONNECTOR ASSEMBLY STANDARD EDGE II, .100 CENTERLINE
0 PLC ±.005		PRODUCT SPEC: 108-9039	
1 PLC ±.005		APPLICATION SPEC: 114-13018	SIZE: A100779 CAGE CODE: 5530843 DRAWING NO: 5530843
2 PLC ±.005		WEIGHT: -	
3 PLC ±.005		FINISH: #2	RESTRICTED TO: -
4 PLC ±.005		MATERIAL: -	SCALE: 4:1
ANGLES ±.2		FINISH: -	SHEET 2 OF 4
MATERIAL: -		FINISH: -	REV: E7
FINISH: -		FINISH: -	CUSTOMER DRAWING

LOC	DIST	REVISIONS					
GP	00	P	LTN	DESCRIPTION	DATE	DWN	APVD
-	-	-	-	SEE SHEET 1	-	-	-

OBSOLETE	8-5530843-2
OBSOLETE	8-5530843-1
OBSOLETE	4-5530843-1
OBSOLETE	1-5530843-9
OBSOLETE	1-5530843-2
	PART NUMBER

OMITTED PIN	BOARD RETENTION FEATURE LOCATION (SEE DETAIL Y)	FINISH	Z	J	D	C	B	A	X	NO. OF DUAL POSITIONS	PART NUMBER
			0.686	-	.500	.700	-	-	5	6	8-5530843-6
		△6	1.286	.187	1.100	1.300	1.350	1.460	11	12	8-5530843-5
19, 20, 21, 22, 23, 24, 27, 28, 31, 32, 35, 36, 39 40, 43, 44, 45, 46, 47, 48, 51, 52, 55, 56, 59, 60	-	△6	3.186	.125	3.000	3.200	3.250	3.360	30	31	8-5530843-4
	3, 4, 5, 6, 19, 20, 21, 22	△6	1.286	.125	1.100	1.300	1.350	1.460	11	12	8-5530843-3
	-	△6	.386	.125	.200	.400	.450	.560	2	3	7-5530843-7
	-	△6	.686	.187	.500	.700	.750	.860	5	6	7-5530843-6
	-	△6	.686	.125	.500	.700	.750	.860	5	6	7-5530843-5
	-	△5	3.186	.125	3.000	3.200	3.250	3.360	30	31	7-5530843-0
	-	△6	3.186	.125	3.000	3.200	3.250	3.360	30	31	6-5530843-5
△ OBSOLETE	-	△6	6.086	.125	5.900	6.100	6.150	6.260	59	60	5-5530843-5
	-	△6	2.086	.125	1.900	2.100	2.150	2.260	19	20	5-5530843-4
	-	△6	1.786	.125	1.600	1.800	1.850	1.960	16	17	5-5530843-3
	-	△6	1.086	.125	.900	1.100	1.150	1.260	9	10	5-5530843-0
	-	△5	1.886	.125	1.700	1.900	1.950	2.060	17	18	2-5530843-7
	-	△6	3.586	.125	3.400	3.600	3.650	3.760	34	35	2-5530843-3
	-	△6	5.086	.187	4.900	5.100	5.150	5.260	49	50	2-5530843-2
	-	△6	4.086	.187	3.900	4.100	4.150	4.260	39	40	2-5530843-0
	-	△6	3.086	.187	2.900	3.100	3.150	3.260	29	30	1-5530843-8
	-	△6	2.586	.187	2.400	2.600	2.650	2.760	24	25	1-5530843-6
	-	△6	4.386	.125	4.200	4.400	4.450	4.560	42	43	1-5530843-0
	-	△6	3.686	.125	3.500	3.700	3.750	3.860	35	36	5530843-8
	-	△6	3.086	.125	2.900	3.100	3.150	3.260	29	30	5530843-7
	-	△6	2.886	.125	2.700	2.900	2.950	3.060	27	28	5530843-6
	-	△6	2.586	.125	2.400	2.600	2.650	2.760	24	25	5530843-5
	-	△6	2.286	.125	2.100	2.300	2.350	2.460	21	22	5530843-4
	-	△6	1.886	.125	1.700	1.900	1.950	2.060	17	18	5530843-3
	-	△6	1.586	.125	1.400	1.600	1.650	1.760	14	15	5530843-2
	-	△6	1.286	.125	1.100	1.300	1.350	1.460	11	12	5530843-1

THIS DRAWING IS A CONTROLLED DOCUMENT. DIMENSIONS: INCHES. TOLERANCES UNLESS OTHERWISE SPECIFIED: 0 PLC ±.005, 1 PLC ±.005, 2 PLC ±.005, 3 PLC ±.005, 4 PLC ±.005, ANGLES ±.02. MATERIAL: FINISH: CUSTOMER DRAWING. DWG: JWF/GRZYBOWSKI, CHK: E. HOWARD, APVD: M. PERCZYNSKI, DATE: 30OCT2009. PRODUCT SPEC: 108-9039, APPLICATION SPEC: 114-13018, WEIGHT: A100779, SCALE: 4:1, SHEET 3 OF 4, REV: E7. **STE** TE Connectivity. CONNECTOR ASSEMBLY STANDARD EDGE II, .100 CENTERLINE.

LOC	DIST	REVISIONS			
P	LTN	DESCRIPTION	DATE	DWN	APVD
-	-	SEE SHEET 1	-	-	-

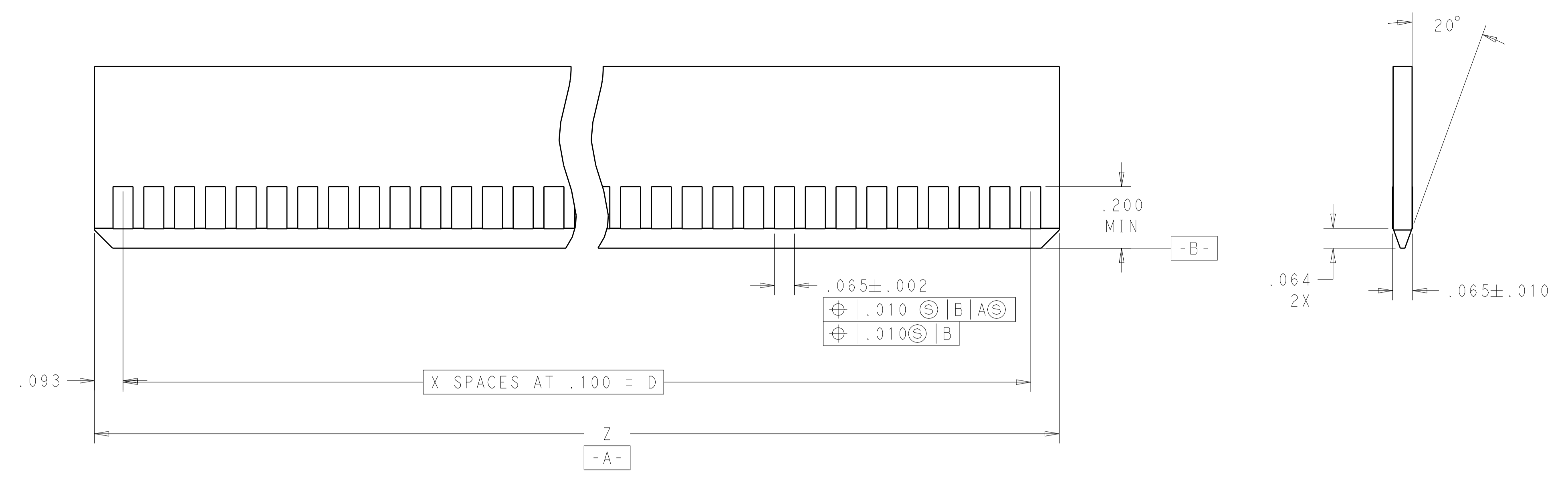

RECOMMENDED MAIN BOARD EDGE CONFIGURATION

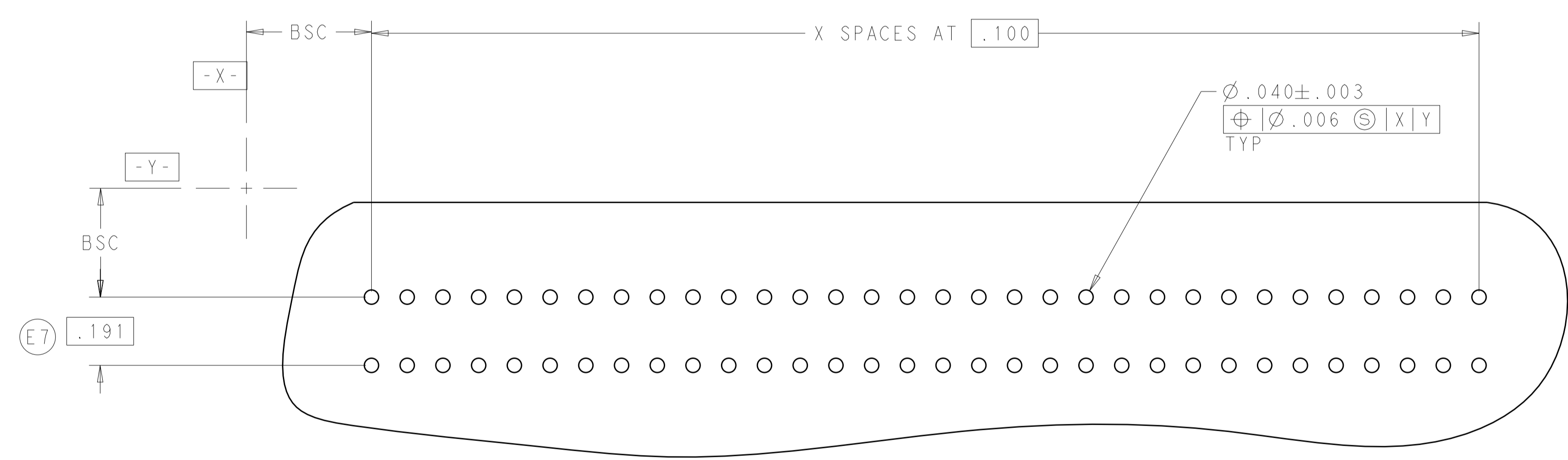

RECOMMENDED PC BOARD HOLE LAYOUT

THIS DRAWING IS A CONTROLLED DOCUMENT.		DWN: AWF/GRZYBOWSKI	30OCT2009	 TE Connectivity
DIMENSIONS: INCHES		CHK: E. HOWARD	APVD: M. PERCHER	
TOLERANCES UNLESS OTHERWISE SPECIFIED: 0 PLC ±. 1 PLC ±.005 2 PLC ±. 3 PLC ±. 4 PLC ±. ANGLES ±. FINISH #2		NAME: M. PERCHER	30OCT2009	PRODUCT SPEC: 108-9039 APPLICATION SPEC: 114-13018
MATERIAL: -		SIZE: A1	CAGE CODE: 00779	DRAWING NO: C=5530843 RESTRICTED TO: -
CUSTOMER DRAWING		SCALE: 4:1	SHEET: 4 OF 4	REV: E7

Компания «Life Electronics» занимается поставками электронных компонентов импортного и отечественного производства от производителей и со складов крупных дистрибьюторов Европы, Америки и Азии.

С конца 2013 года компания активно расширяет линейку поставок компонентов по направлению коаксиальный кабель, кварцевые генераторы и конденсаторы (керамические, пленочные, электролитические), за счёт заключения дистрибьюторских договоров

Мы предлагаем:

- Конкурентоспособные цены и скидки постоянным клиентам.
- Специальные условия для постоянных клиентов.
- Подбор аналогов.
- Поставку компонентов в любых объемах, удовлетворяющих вашим потребностям.
- Приемлемые сроки поставки, возможна ускоренная поставка.
- Доставку товара в любую точку России и стран СНГ.
- Комплексную поставку.
- Работу по проектам и поставку образцов.
- Формирование склада под заказчика.
- Сертификаты соответствия на поставляемую продукцию (по желанию клиента).
- Тестирование поставляемой продукции.
- Поставку компонентов, требующих военную и космическую приемку.
- Входной контроль качества.
- Наличие сертификата ISO.

В составе нашей компании организован Конструкторский отдел, призванный помогать разработчикам, и инженерам.

Конструкторский отдел помогает осуществить:

- Регистрацию проекта у производителя компонентов.
- Техническую поддержку проекта.
- Защиту от снятия компонента с производства.
- Оценку стоимости проекта по компонентам.
- Изготовление тестовой платы монтаж и пусконаладочные работы.



Тел: +7 (812) 336 43 04 (многоканальный)
Email: org@lifeelectronics.ru