



## IS39LV512 / IS39LV010 / IS39LV040 512 Kbit / 1Mbit / 4Mbit 3.0 Volt-only CMOS Flash Memory

### FEATURES

- **Single Power Supply Operation**
  - Low voltage range: 2.70 V - 3.60 V
- **Memory Organization**
  - IS39LV512: 64K x 8 (512 Kbit)
  - IS39LV010: 128K x 8 (1 Mbit)
  - IS39LV040: 512K x 8 (4 Mbit)
- **High Performance Read**
  - 70 ns access time
- **Cost Effective Sector/Block Architecture**
  - Uniform 4 Kbyte sectors
  - Uniform 64 Kbyte blocks (sector group - except IS39LV512)
- **Data# Polling and Toggle Bit Features**
- **Hardware Data Protection**
- **Automatic Erase and Byte Program**
  - Build-in automatic program verification
  - Typical 16  $\mu$ s/byte programming time
  - Typical 55 ms sector/block/chip erase time
- **Low Power Consumption**
  - Typical 4 mA active read current
  - Typical 8 mA program/erase current
  - Typical 0.1  $\mu$ A CMOS standby current
- **High Product Endurance**
  - Guarantee 100,000 program/erase cycles per single sector (preliminary)
  - Minimum 20 years data retention
- **Industrial Standard Pin-out and Packaging**
  - 32-pin (8 mm x 14 mm) VSOP
  - 32-pin PLCC
  - Optional lead-free (Pb-free) package
- **Operation temperature range**
  - IS39LV512/010                    -40°C~+85°C
  - IS39LV040                        0°C~+85°C

### GENERAL DESCRIPTION

The IS39LV512/010/040 are 512 Kbit/1 Mbit/4 Mbit 3.0 Volt-only Flash Memories. These devices are designed to use a single low voltage, range from 2.70 Volt to 3.60 Volt, power supply to perform read, erase and program operations. The 12.0 Volt  $V_{PP}$  power supply for program and erase operations are not required. The devices can be programmed in standard EPROM programmers as well.

The memory array of IS39LV512 is divided into uniform 4 Kbyte sectors for data or code storage. The memory arrays of IS39LV010/040 are divided into uniform 4 Kbyte sectors or uniform 64 Kbyte blocks (sector group - consists of sixteen adjacent sectors). The sector or block erase feature allows users to flexibly erase a memory area as small as 4 Kbyte or as large as 64 Kbyte by one single erase operation without affecting the data in others. The chip erase feature allows the whole memory array to be erased in one single erase operation. The devices can be programmed on a byte-by-byte basis after performing the erase operation.

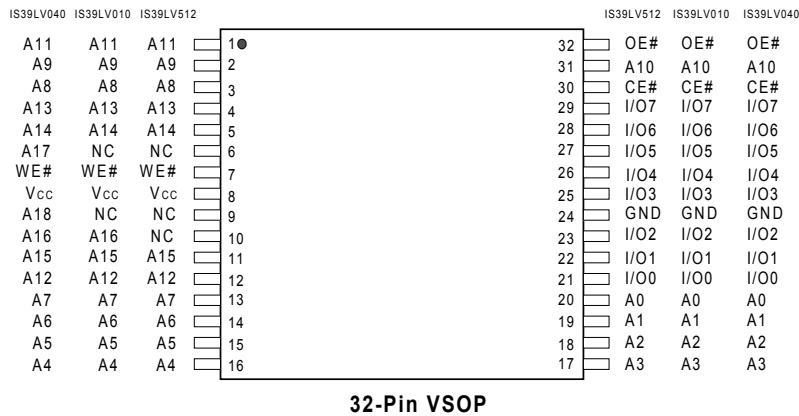
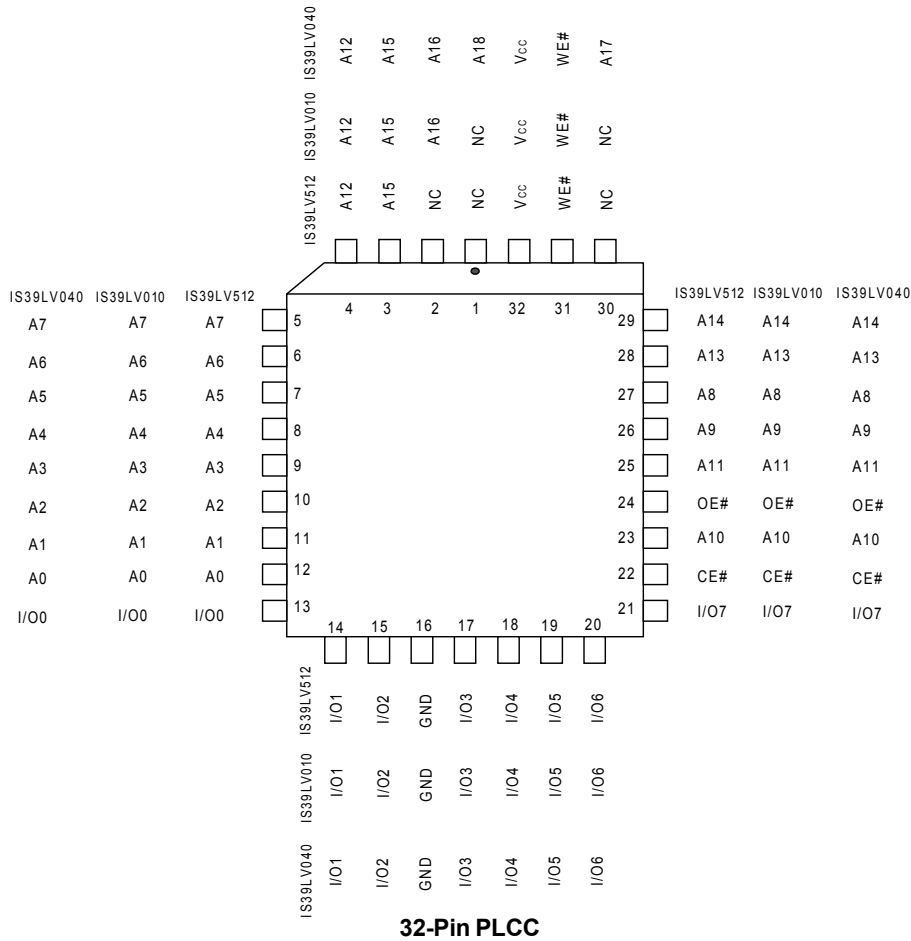
The devices have a standard microprocessor interface as well as a JEDEC standard pin-out/command set. The program operation is executed by issuing the program command code into command register. The internal control logic automatically handles the programming voltage ramp-up and timing. The erase operation is executed by issuing the chip erase, block, or sector erase command code into command register. The internal control logic automatically handles the erase voltage ramp-up and timing. The preprogramming on the array which has not been programmed is not required before an erase operation. The devices offer Data# Polling and Toggle Bit functions, the progress or completion of program and erase operations can be detected by reading the Data# Polling on I/O7 or the Toggle Bit on I/O6.

The IS39LV512/010/040 are manufactured on pFLASH™'s advanced nonvolatile CMOS technology. The devices are offered in 32-pin VSOP and PLCC packages with 70 ns access time.



# IS39LV512 / IS39LV010 / IS39LV040

## CONNECTION DIAGRAMS

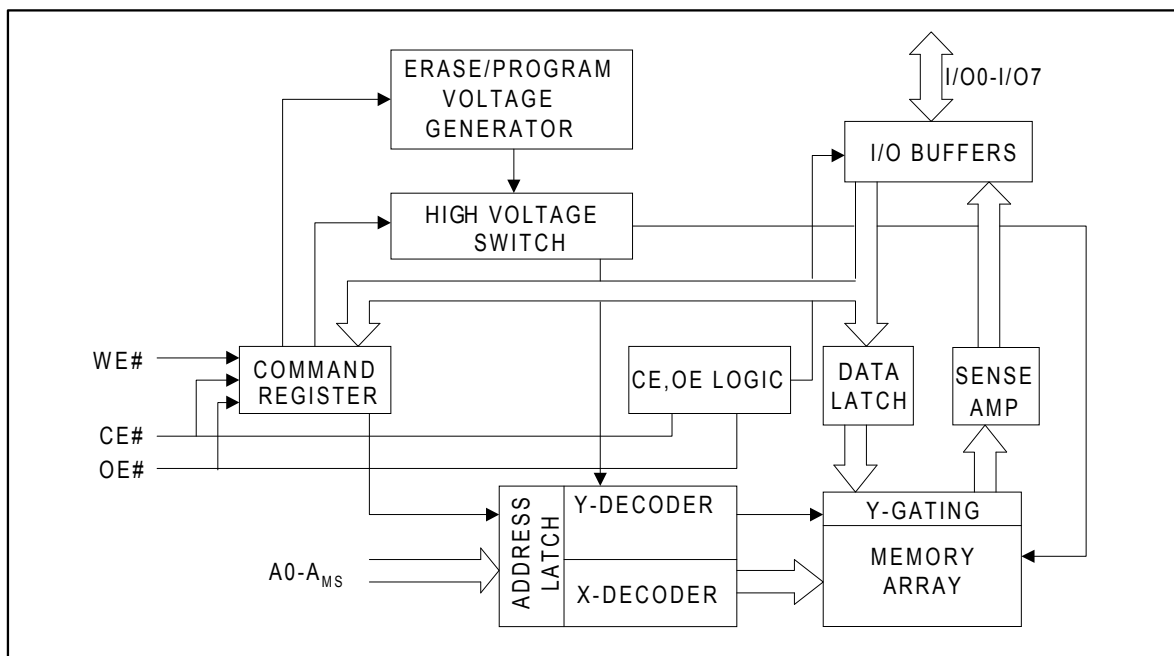


**PIN DESCRIPTIONS**

SYMBOL	TYPE	DESCRIPTION
A0 - A <sub>MS</sub> <sup>(1)</sup>	INPUT	Address Inputs: For memory addresses input. Addresses are internally latched on the falling edge of WE# during a write cycle.
CE#	INPUT	Chip Enable: CE# goes low activates the device's internal circuitries for device operation. CE# goes high deselects the device and switches into standby mode to reduce the power consumption.
WE#	INPUT	Write Enable: Activate the device for write operation. WE# is active low.
OE#	INPUT	Output Enable: Control the device's output buffers during a read cycle. OE# is active low.
I/O0 - I/O7	INPUT/ OUTPUT	Data Inputs/Outputs: Input command/data during a write cycle or output data during a read cycle. The I/O pins float to tri-state when OE# are disabled.
VCC		Device Power Supply
GND		Ground
NC		No Connection

**Note:**

1. A<sub>MS</sub> is the most significant address where A<sub>MS</sub> = A15 for IS39LV512, A16 for IS39LV010, and A18 for IS39LV040.

**BLOCK DIAGRAM**

**DEVICE OPERATION**
**READ OPERATION**

The access of IS39LV512/010/040 are similar to EPROM. To read data, three control functions must be satisfied:

- CE# is the chip enable and should be pulled low ( $V_{IL}$ ).
- OE# is the output enable and should be pulled low ( $V_{IL}$ ).
- WE# is the write enable and should remain high ( $V_{IH}$ ).

**PRODUCT IDENTIFICATION**

The product identification mode can be used to identify the manufacturer and the device through hardware or software read ID operation. See Table 1 for pFLASH™ Manufacturer ID and Device ID. The hardware ID mode is activated by applying a 12.0 Volt on A9 pin, typically used by an external programmer for selecting the right programming algorithm for the devices. Refer to Table 2 for Bus Operation Modes. The software ID mode is activated by a three-bus-cycle command. See Table 3 for Software Command Definition.

**BYTE PROGRAMMING**

The programming is a four-bus-cycle operation and the data is programmed into the devices (to a logical “0”) on a byte-by-byte basis. See Table 3 for Software Command Definition. A program operation is activated by writing the three-byte command sequence followed by program address and one byte of program data into the devices. The addresses are latched on the falling edge of WE# or CE# whichever occurs later, and the data are latched on the rising edge of WE# or CE# whichever occurs first. The internal control logic automatically handles the internal programming voltages and timing.

A data “0” can not be programmed back to a “1”. Only erase operation can convert the “0”s to “1”s. The Data# Polling on I/O7 or Toggle Bit on I/O6 can be used to detect the progress or completion of a program cycle.



**DEVICE OPERATION (CONTINUED)**

**CHIP ERASE**

The entire memory array can be erased through a chip erase operation. Pre-programs the devices are not required prior to a chip erase operation. Chip erase starts immediately after a six-bus-cycle chip erase command sequence. All commands will be ignored once the chip erase operation has started. The devices will return to standby mode after the completion of chip erase.

**SECTOR AND BLOCK ERASE**

The memory array of IS39LV512/010/040 are organized into uniform 4 Kbyte sectors. A sector erase operation allows to erase any individual sector without affecting the data in others. The memory array of IS39LV010/040, excluding IS39LV512, are also organized into uniform 64 Kbyte blocks (sector group - consists of sixteen adjacent sectors). A block erase operation allows to erase any individual block. The sector or block erase operation is similar to chip erase.

**I/O7 DATA# POLLING**

The IS39LV512/010/040 provide a Data# Polling feature to indicate the progress or completion of a program and erase cycles. During a program cycle, an attempt to read the devices will result in the complement of the last loaded data on I/O7. Once the program operation is completed, the true data of the last loaded data is valid on all outputs. During a sector, block, or chip erase cycle, an attempt to read the device will result a “0” on I/O7. After the erase operation is completed, an attempt to read the device will result a “1” on I/O7.

**I/O6 TOGGLE BIT**

The IS39LV512/010/040 also provide a Toggle Bit feature to detect the progress or completion of a program and erase cycles. During a program or erase cycle, an attempt to read data from the device will result a toggling between “1” and “0” on I/O6. When the program or erase operation is complete, I/O6 will stop toggling and valid data will be read. Toggle bit may be accessed at any time during a program or erase cycle.

**HARDWARE DATA PROTECTION**

Hardware data protection protects the devices from unintentional erase or program operation. It is performed in the following ways: (a) V<sub>CC</sub> sense: if V<sub>CC</sub> is below 1.8 V (typical), the write operation is inhibited. (b) Write inhibit: holding any of the signal OE# low, CE# high, or WE# high inhibits a write cycle. (c) Noise filter: pulses of less than 5 ns (typical) on the WE# or CE# input will not initiate a write operation.

**Table 1. Product Identification**

Product Identification	Data
Manufacturer ID	9Dh
Device ID:	
IS39LV512	1Bh
IS39LV010	1Ch
IS39LV040	3Eh



**SECTOR/BLOCK ADDRESS TABLE**

Memory Density			Block	Block Size (Kbytes)	Sector	Sector Size (Kbytes)	Address Range
512Kbit	1 Mbit	4 Mbit	Block 0 <sup>(2)</sup>	64	Sector 0	4	00000h - 00FFFh
					Sector 1	4	01000h - 01FFFh
					:	:	:
					Sector 15	4	0F000h - 0FFFFh
			Block 1	64	Sector 16	4	10000h - 10FFFh
					Sector 17	4	11000h - 11FFFh
					:	:	:
					Sector 31	4	1F000h - 1FFFFh
			Block 2	64	"	"	20000h - 2FFFFh
			Block 3	64	"	"	30000h - 3FFFFh
			Block 4	64	"	"	40000h - 4FFFFh
			Block 5	64	"	"	50000h - 5FFFFh
Block 6	64		"	"	60000h - 6FFFFh		
Block 7	64		"	"	70000h - 7FFFFh		

Notes:

1. A Block is a 64 Kbyte sector group which consists of sixteen adjacent sectors of 4 Kbyte each.
2. Block erase feature is available for IS39LV010/040 only. The chip erase command should be used to erase the Block 0 for the IS39LV512.

**OPERATING MODES**

Table 2. Bus Operation Modes

Mode	CE#	OE#	WE#	ADDRESS	I/O
Read	V <sub>IL</sub>	V <sub>IL</sub>	V <sub>IH</sub>	X (1)	D <sub>OUT</sub>
Write	V <sub>IL</sub>	V <sub>IH</sub>	V <sub>IL</sub>	X	D <sub>IN</sub>
Standby	V <sub>IH</sub>	X	X	X	High Z
Output Disable	X	V <sub>IH</sub>	X	X	High Z
Product Identification Hardware	V <sub>IL</sub>	V <sub>IL</sub>	V <sub>IH</sub>	A2 - A <sub>MS</sub> <sup>(2)</sup> = X, A9 = V <sub>H</sub> <sup>(3)</sup> , A1 = V <sub>IL</sub> , A0 = V <sub>IL</sub>	Manufacturer ID
				A2 - A <sub>MS</sub> <sup>(2)</sup> = X, A9 = V <sub>H</sub> <sup>(3)</sup> , A1 = V <sub>IL</sub> , A0 = V <sub>IH</sub>	Device I

## Notes:

1. X can be V<sub>IL</sub>, V<sub>IH</sub> or addresses.
2. A<sub>MS</sub> = Most significant address;  
A<sub>MS</sub> = A15 for IS39LV512, A16 for IS39LV010, and A18 for IS39LV040.
3. V<sub>H</sub> = 12.0 V ± 0.5 V.

**COMMAND DEFINITION**
**Table 3. Software Command Definition**

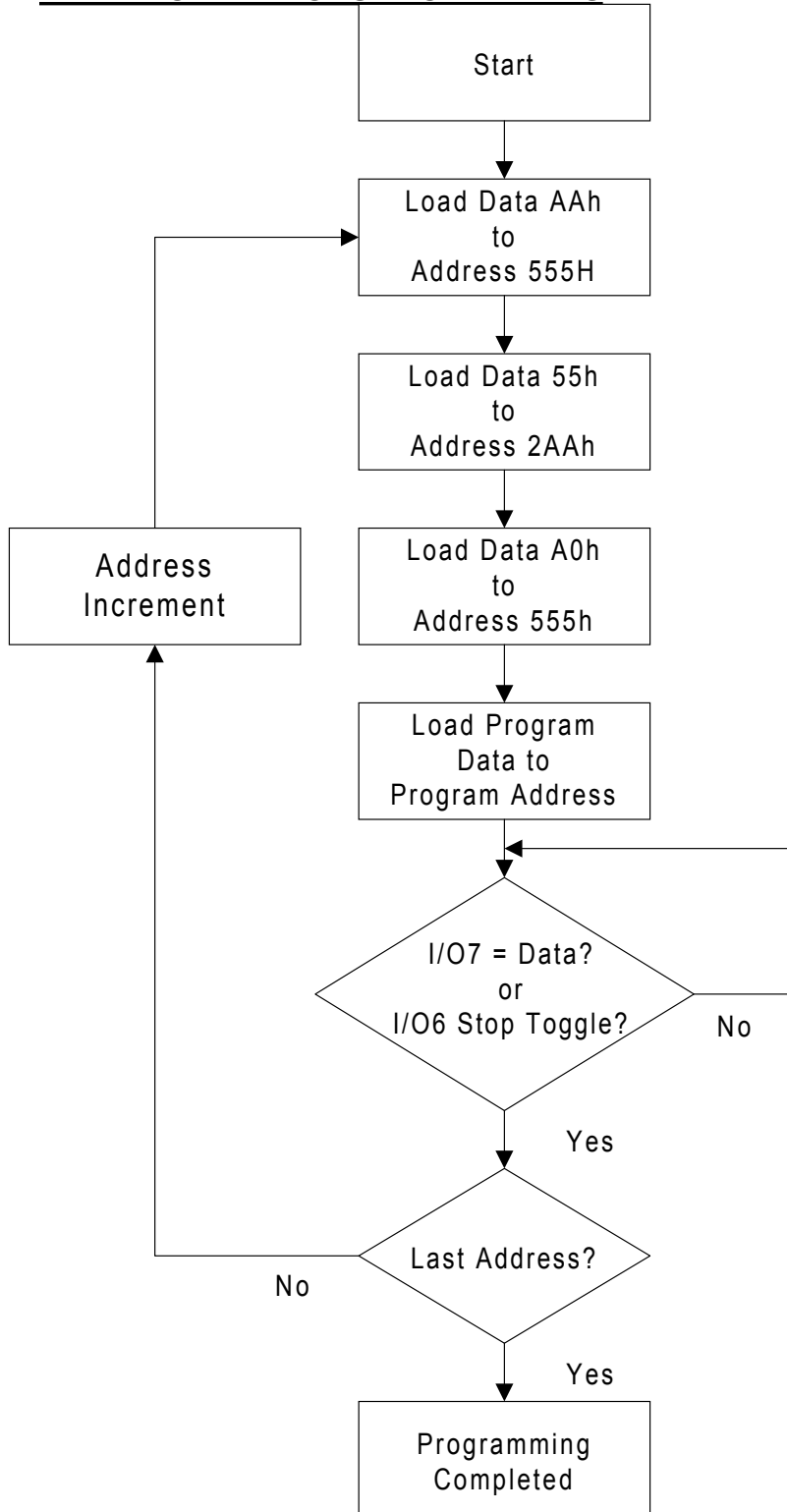
Command Sequence	Bus Cycle	1st Bus Cycle Addr Data	2nd Bus Cycle Addr Data	3rd Bus Cycle Addr Data	4th Bus Cycle Addr Data	5th Bus Cycle Addr Data	6th Bus Cycle Addr Data
Read	1	Addr D <sub>OUT</sub>					
Chip Erase	6	555h AAh	2AAh 55h	555h 80h	555h AAh	2AAh 55h	555h 10h
Sector Erase	6	555h AAh	2AAh 55h	555h 80h	555h AAh	2AAh 55h	SA <sup>(1)</sup> 30h
Block Erase	6	555h AAh	2AAh 55h	555h 80h	555h AAh	2AAh 55h	BA <sup>(2)</sup> 50h
Byte Program	4	555h AAh	2AAh 55h	555h A0h	Addr D <sub>IN</sub>		
Product ID Entry	3	555h AAh	2AAh 55h	555h 90h			
Product ID Exit <sup>(3)</sup>	3	555h AAh	2AAh 55h	555h F0h			
Product ID Exit <sup>(3)</sup>	1	XXXh F0h					

**Notes:**

1. SA = Sector address of the sector to be erased.
2. BA = Block address of the block to be erased.
3. Either one of the Product ID Exit command can be used.

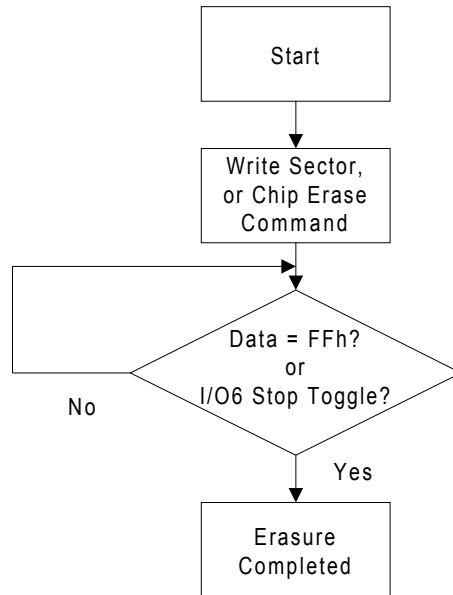


**DEVICE OPERATIONS FLOWCHARTS**

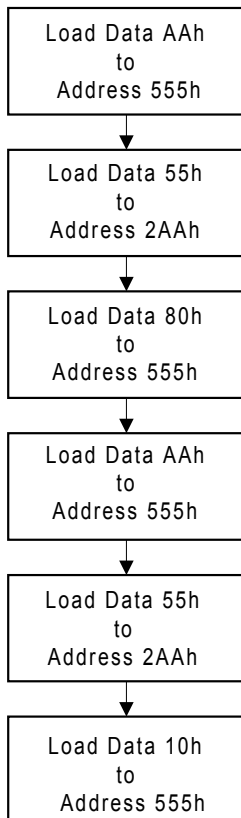


**Chart 1. Automatic Programming Flowchart**

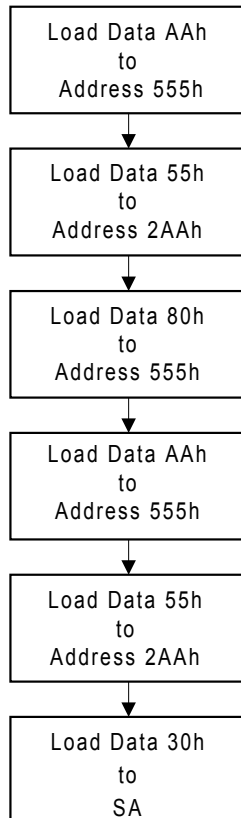
**DEVICE OPERATIONS FLOWCHARTS (CONTINUED)**



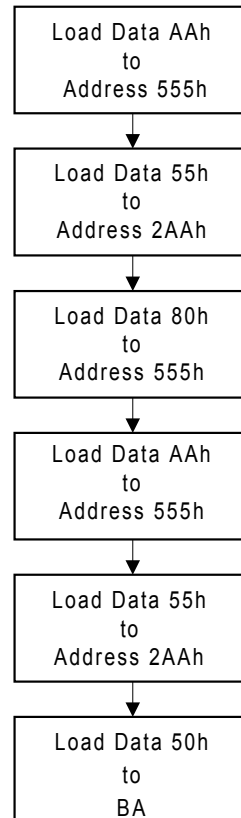
**CHIP ERASE COMMAND**



**SECTOR ERASE COMMAND**

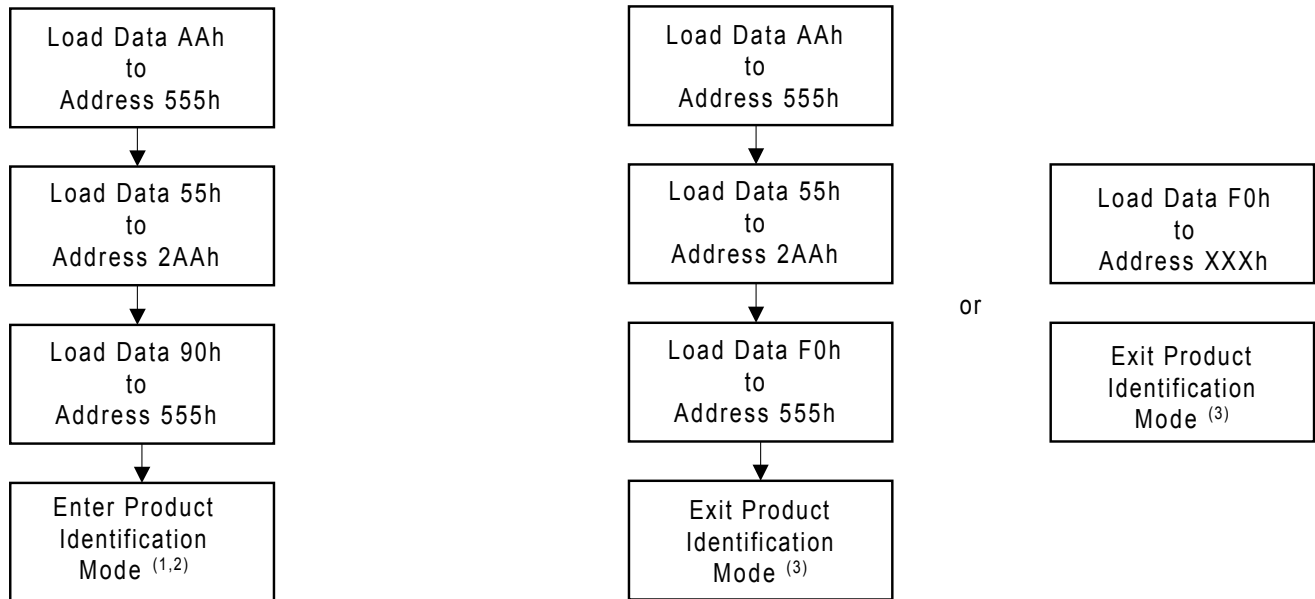


**BLOCK ERASE COMMAND**



**Chart 2. Automatic Erase Flowchart**

**DEVICE OPERATIONS FLOWCHARTS (CONTINUED)**



Notes:

1. The device will enter Product Identification mode after executing the Product ID Entry command.
2. Under Product Identification mode, the Manufacturer ID and Device ID of devices can be read at address X0000h and X0001h where X = Don't Care.
3. The device returns to standby operation.

**Chart 3. Software Product Identification Entry/Exit Flowchart**

**ABSOLUTE MAXIMUM RATINGS** <sup>(1)</sup>

Temperature Under Bias	-65°C to +125°C
Storage Temperature	-65°C to +125°C
Surface Mount Lead Soldering Temperature	240°C 3 Seconds
Input Voltage with Respect to Ground on All Pins except A9 pin (2)	-0.5V to VCC + 0.5 V
Input Voltage with Respect to Ground on A9 pin (3)	-0.5V to +13.0 V
All Output Voltage with Respect to Ground	-0.5V to VCC + 0.5 V
VCC (2)	-0.5V to +6.0 V

## Notes:

1. Stresses under those listed in “Absolute Maximum Ratings” may cause permanent damage to the device. This is a stress rating only. The functional operation of the device or any other conditions under those indicated in the operational sections of this specification is not implied. Exposure to absolute maximum rating condition for extended periods may affect device reliability.
2. Maximum DC voltage on input or I/O pins are  $V_{CC} + 0.5V$ . During voltage transitioning period, input or I/O pins may overshoot to  $V_{CC} + 2.0V$  for a period of time up to 20 ns. Minimum DC voltage on input or I/O pins are -0.5V. During voltage transitioning period, input or I/O pins may undershoot GND to -2.0V for a period of time up to 20 ns.
3. Maximum DC voltage on A9 pin is +13.0 V. During voltage transitioning period, A9 pin may overshoot to +14.0 V for a period of time up to 20 ns. Minimum DC voltage on A9 pin is -0.5V. During voltage transitioning period, A9 pin may undershoot GND to -2.0V for a period of time up to 20 ns.

**DC AND AC OPERATING RANGE**

Part Number	IS39LV512/010	IS39LV040
Operating Temperature	-40° to +85°C	0° to +85°C
Vcc Power Supply	2.70 V - 3.60 V	2.70 V - 3.60 V

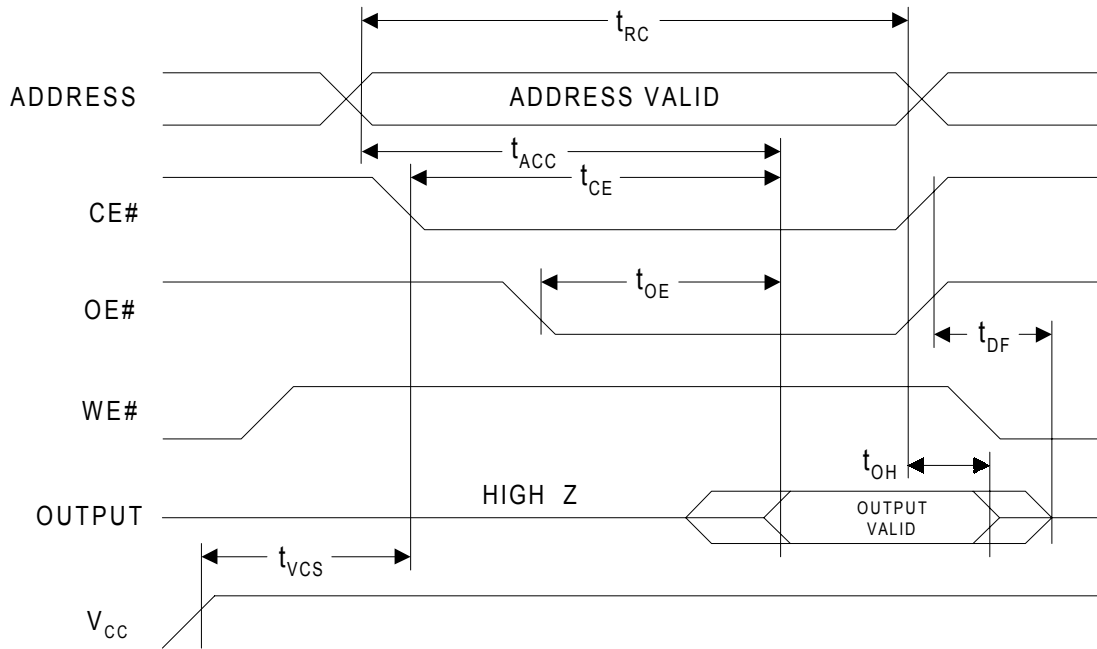
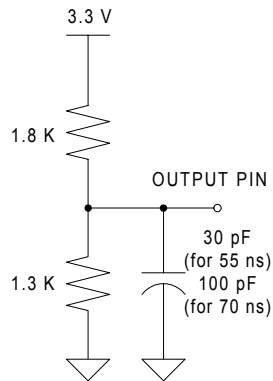
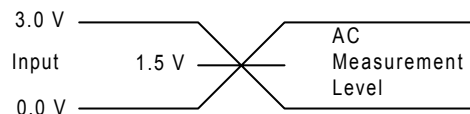
**DC CHARACTERISTICS**

Symbol	Parameter	Condition	Min	Typ	Max	Units
ILI	Input Load Current	V <sub>IN</sub> = 0 V to V <sub>CC</sub>			1	mA
ILO	Output Leakage Current	V <sub>I/O</sub> = 0 V to V <sub>CC</sub>			1	mA
ISB1	VCC Standby Current CMOS	CE#, OE# = V <sub>CC</sub> - 0.3 V		0.1	5	mA
ISB2	VCC Standby Current TTL	CE# = V <sub>IH</sub> to V <sub>CC</sub>		0.05	3	mA
ICC1	VCC Active Read Current	f = 5 MHz; I <sub>OUT</sub> = 0 mA		4	15	mA
ICC2(1)	VCC Program/Erase Current			8	20	mA
VIL	Input Low Voltage		-0.5		0.8	V
VIH	Input High Voltage		0.7 V <sub>CC</sub>		V <sub>CC</sub> + 0.3	V
VOL	Output Low Voltage	I <sub>OL</sub> = 2.1 mA; V <sub>CC</sub> = V <sub>CCmin</sub>			0.45	V
VOH	Output High Voltage	I <sub>OH</sub> = -100 mA; V <sub>CC</sub> = V <sub>CC min</sub>	V <sub>CC</sub> - 0.2			V

Note: 1. Characterized but not 100% tested.

**AC CHARACTERISTICS****READ OPERATIONS CHARACTERISTICS**

<b>Symbol</b>	<b>Parameter</b>	<b>IS39LV512/010/040</b>		<b>Units</b>
tRC	Read Cycle Time	70		ns
tACC	Address to Output Delay		70	ns
tCE	CE# to Output Delay		70	ns
tOE	OE# to Output Delay		35	ns
tDF	CE# or OE# to Output High Z	0	25	ns
tOH	Output Hold from OE#, CE# or Address, whichever occurred first	0		ns
tVCS	VCC Set-up Time	50		ms

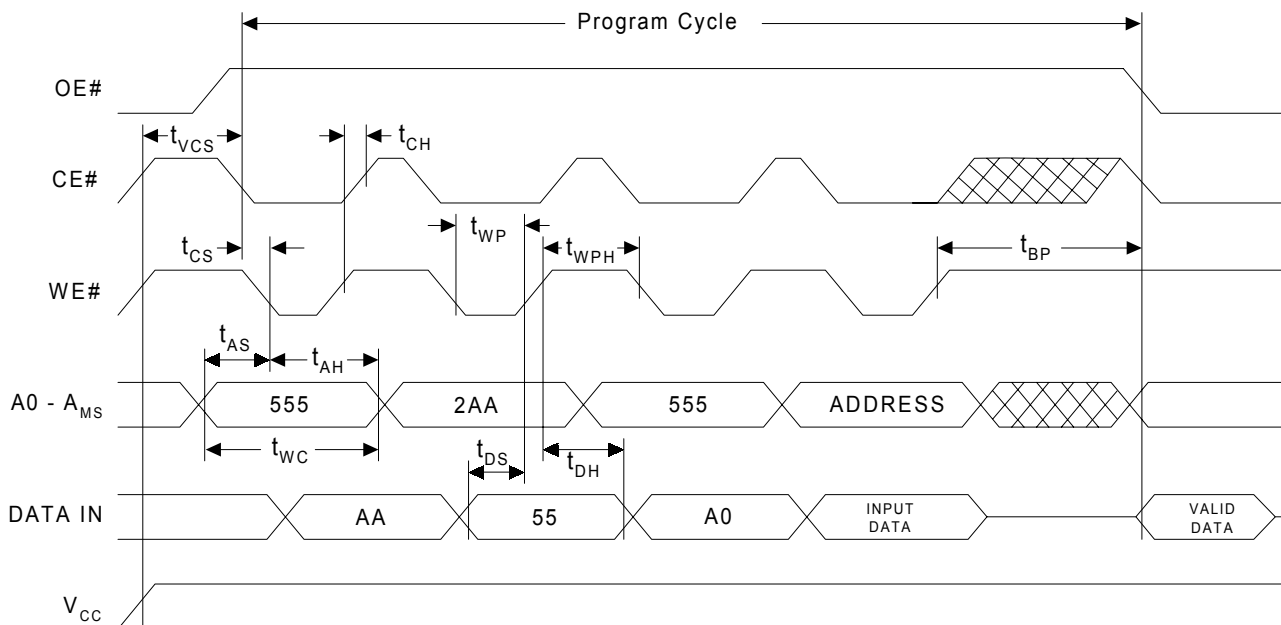
**AC CHARACTERISTICS (CONTINUED)**
**READ OPERATIONS AC WAVEFORMS**

**OUTPUT TEST LOAD**

**INPUT TEST WAVEFORMS AND MEASUREMENT LEVEL**

**PIN CAPACITANCE ( f = 1 MHz, T = 25°C )**

	Typ	Max	Units	Conditions
$C_{IN}$	4	6	pF	$V_{IN} = 0 V$
$C_{OUT}$	8	12	pF	$V_{OUT} = 0 V$

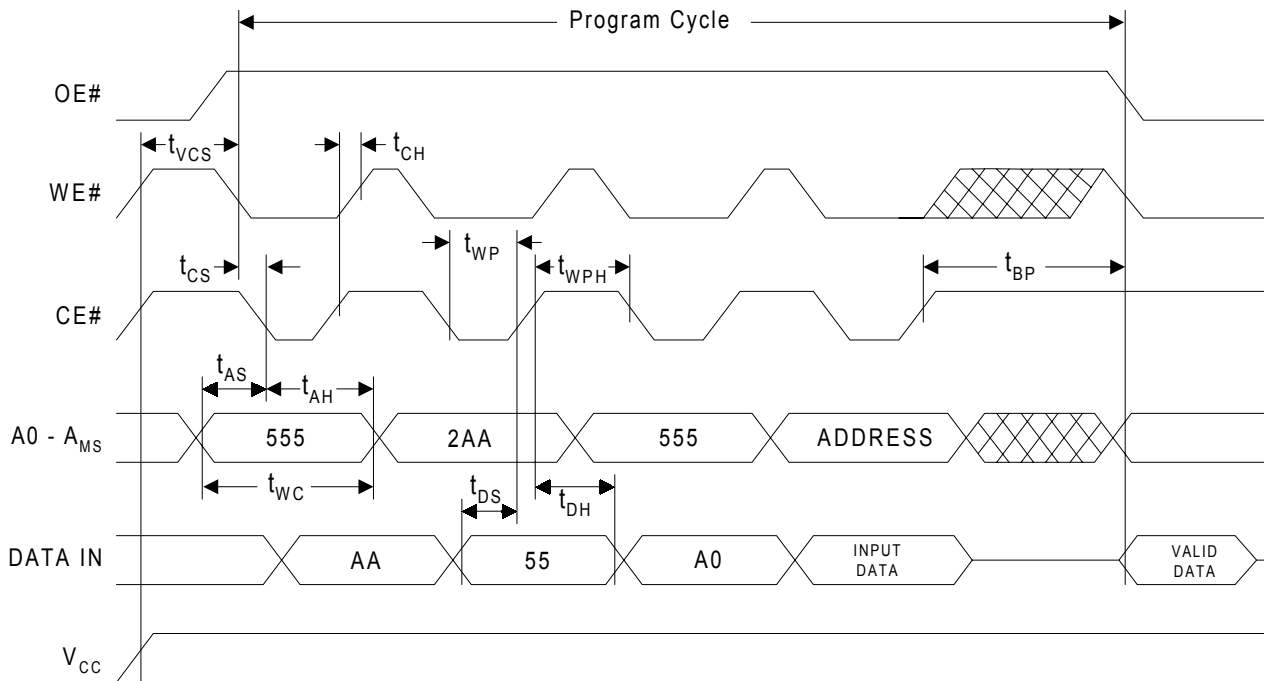
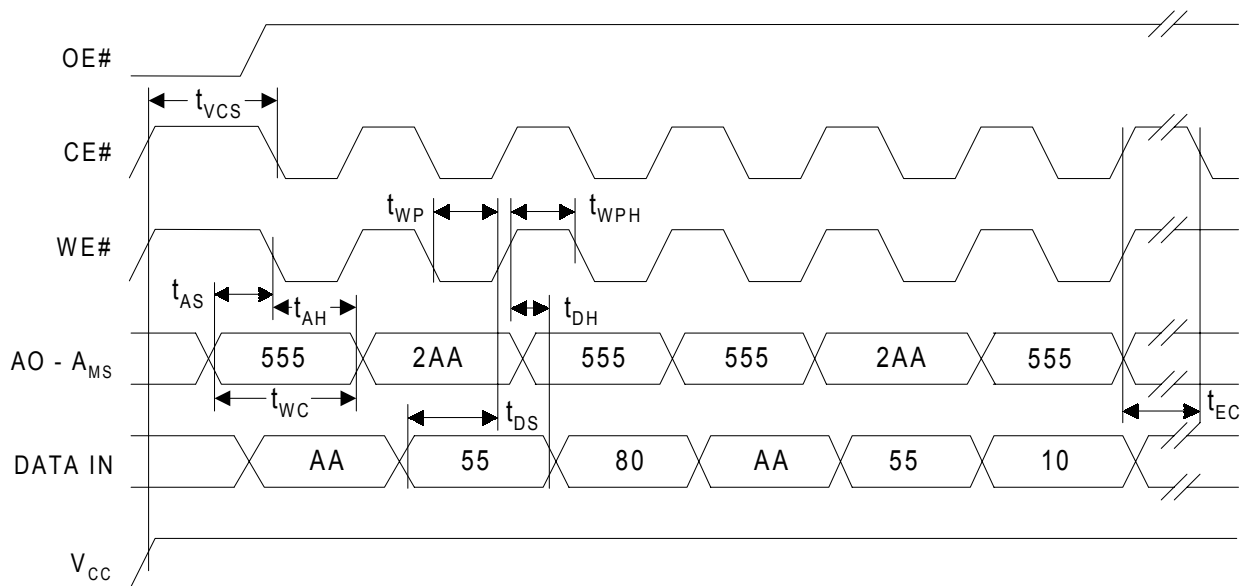
Note: These parameters are characterized but not 100% tested.

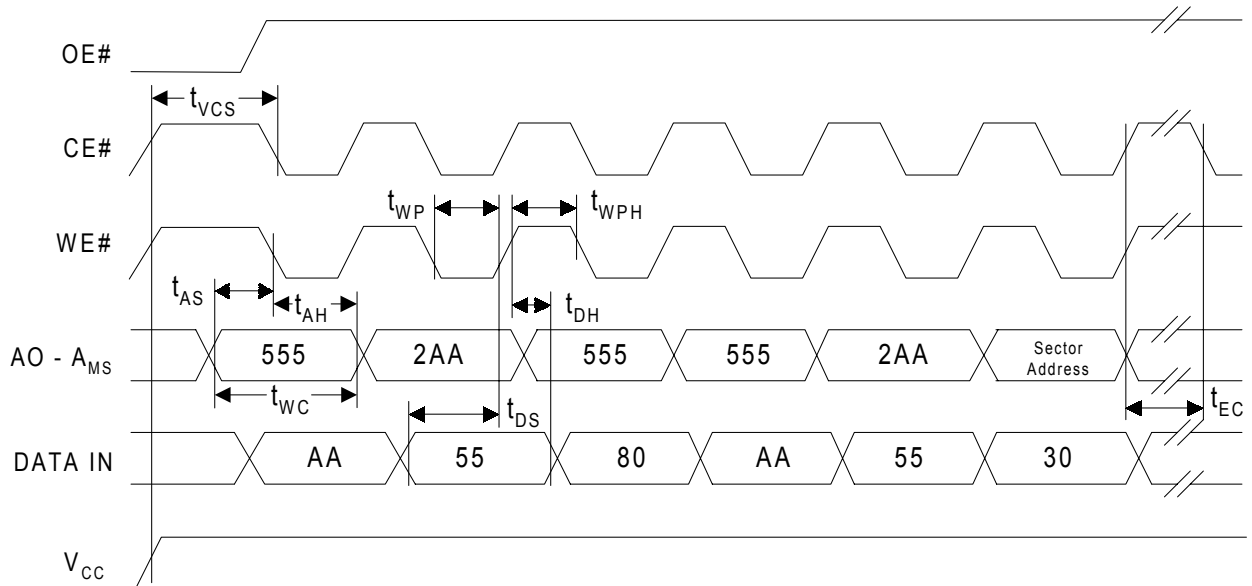
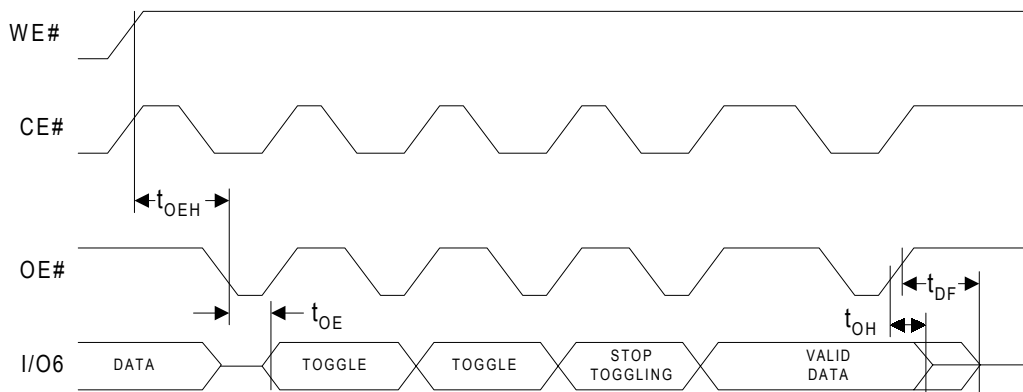
**AC CHARACTERISTICS (CONTINUED)**
**WRITE (PROGRAM/ERASE) OPERATIONS CHARACTERISTICS**

Symbol	Parameter	IS39LV512/010/040		Units
		Min	Max	
t <sub>WC</sub>	Write Cycle Time	70		ns
t <sub>AS</sub>	Address Set-up Time	0		ns
t <sub>AH</sub>	Address Hold Time	30		ns
t <sub>CS</sub>	CE# and WE# Set-up Time	0		ns
t <sub>CH</sub>	CE# and WE# Hold Time	0		ns
t <sub>OE#H</sub>	OE# High Hold Time	10		ns
t <sub>DS</sub>	Data Set-up Time	40		ns
t <sub>DH</sub>	Data Hold Time	0		ns
t <sub>WP</sub>	Write Pulse Width	35		ns
t <sub>WPH</sub>	Write Pulse Width High	20		ns
t <sub>BP</sub>	Byte Programming Time		40	ms
t <sub>EC</sub>	Chip or Block Erase Time		100	ms
t <sub>VCS</sub>	VCC Set-up Time	50		ms

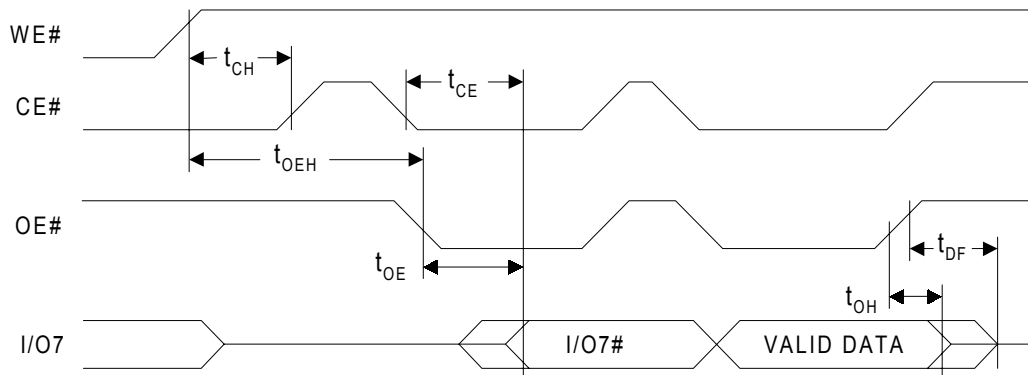
**PROGRAM OPERATIONS AC WAVEFORMS - WE# CONTROLLED**




**AC CHARACTERISTICS (CONTINUED)**

**CHIP ERASE OPERATIONS AC WAVEFORMS**


**AC CHARACTERISTICS (CONTINUED)**
**SECTOR OR BLOCK ERASE OPERATIONS AC WAVEFORMS**

**TOGGLE BIT AC WAVEFORMS**


Note: Toggling CE#, OE#, or both OE# and CE# will operate Toggle Bit.

**AC CHARACTERISTICS (CONTINUED)**
**DATA# POLLING AC WAVEFORMS**


Note: Toggling CE#, OE#, or both OE# and CE# will operate Data# Polling.

**PROGRAM/ERASE PERFORMANCE**

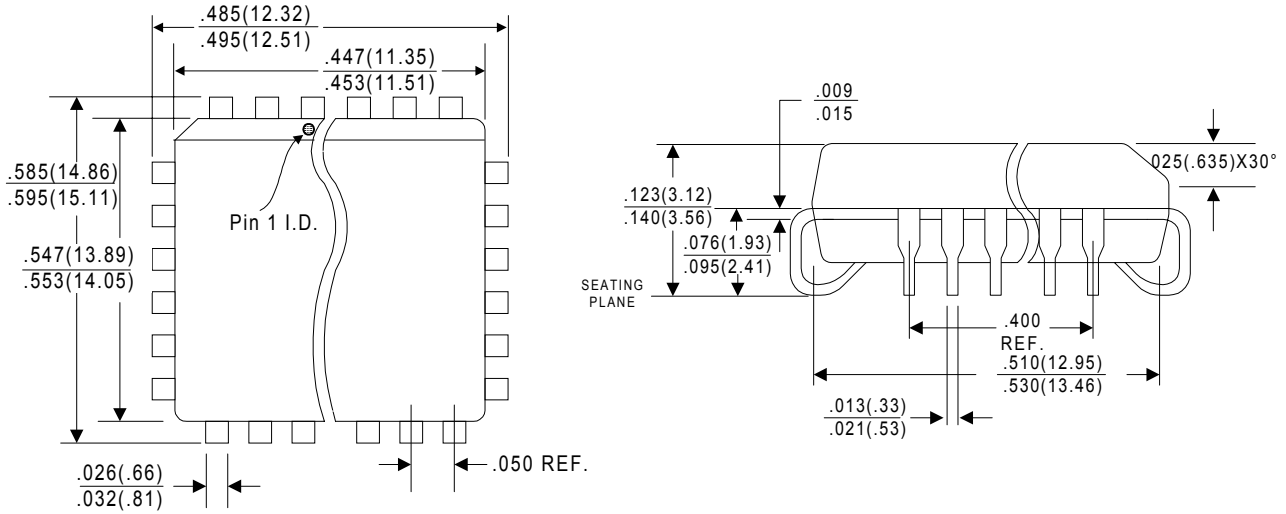
Parameter	Unit	Typ	Max	Remarks
Sector Erase Time	ms	55	100	From writing erase command to erase completion
Block Erase Time	ms	55	100	From writing erase command to erase completion
Chip Erase Time	ms	55	100	From writing erase command to erase completion
Byte Programming Time	ms	16	20	Excludes the time of four-cycle program command execution

Note: 1. These parameters are characterized but not 100% tested.  
2. Preliminary specification only and will be formalized after cycling qualification test.

**PACKAGE TYPE INFORMATION**

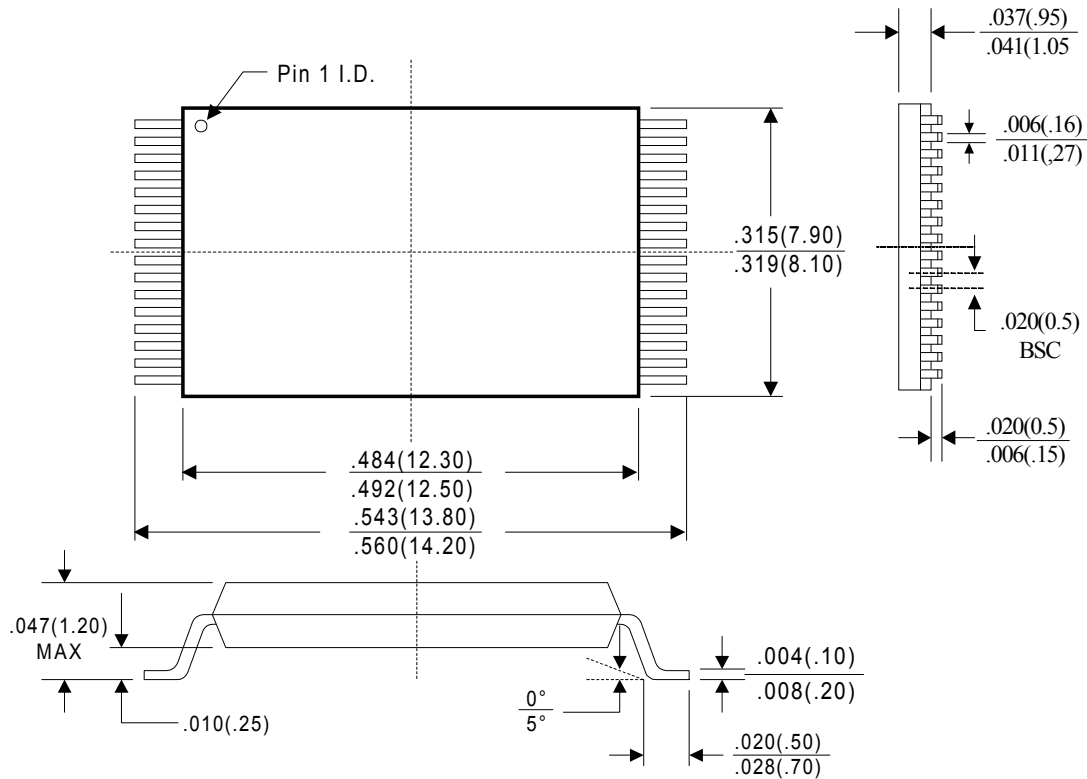
**PLCC**

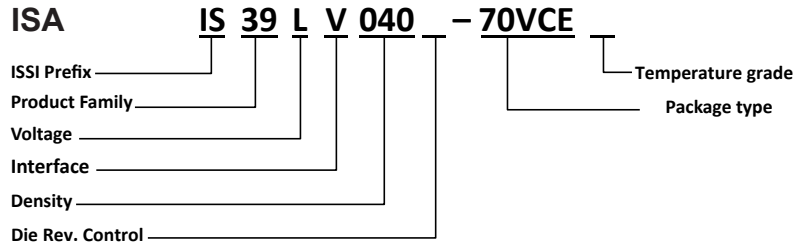
32-Pin Plastic Leaded Chip Carrier Dimensions in Inches (Millimeters)



**VSOP**

32-Pin Thin Small Outline Package (VSOP - 8 mm x 14 mm)( measure in millimeters)





**Flash Product Family**

ISA = 29/39

**ISA Operating Voltage Range**

G/L = 2.70-3.60V

**Die Rev. Control**

Blank = First Rev.

**ISA Interface**

V = ISA x8  
L = ISA x8/x16

**Density**

025 = 256Kb  
512 = 512Kb  
010 = 1Mb  
020 = 2Mb  
040 = 4Mb  
080 = 8Mb  
016 = 16Mb  
032 = 32Mb  
064 = 64Mb  
128 = 128Mb  
256 = 256Mb

**Package Type**

JE = 48 pin TSSOP  
JT = 56 pin TSSOP  
70JCE = 32 pin PLCC  
70VCE = 32 pin VSOP (8x14mm)  
JH = 48 ball (BGA 6x8mm) (Call Factory)  
JI = 64 ball (BGA 11x13mm) (Call Factory)  
JS = WLCSP (Call Factory)  
JW = KGD (Call Factory)

**Lead-Free Package**

E/L = Lead-Free

**Temperature Grade**

E = Extended grade (-40C to +105C)  
A1 = Automotive grade (-40C to +85C)  
A2 = Automotive grade(-40C to +105C)  
A3 = Automotive grade(-40C to +125C)  
Blank = Refer to datasheet



**ORDERING INFORMATION**

Density	Frequency (MHz)	Order Part Number	Package
512K	100	IS39LV512-70JCE	32-pin PLCC
		IS39LV512-70VCE	32-pin VSOP
1M	100	IS39LV010-70JCE	32-pin PLCC
		IS39LV010-70VCE	32-pin VSOP
4M	100	IS39LV040-70JCE	32-pin PLCC
		IS39LV040-70VCE	32-pin VSOP

Компания «Life Electronics» занимается поставками электронных компонентов импортного и отечественного производства от производителей и со складов крупных дистрибьюторов Европы, Америки и Азии.

С конца 2013 года компания активно расширяет линейку поставок компонентов по направлению коаксиальный кабель, кварцевые генераторы и конденсаторы (керамические, пленочные, электролитические), за счёт заключения дистрибьюторских договоров

Мы предлагаем:

- Конкурентоспособные цены и скидки постоянным клиентам.
- Специальные условия для постоянных клиентов.
- Подбор аналогов.
- Поставку компонентов в любых объемах, удовлетворяющих вашим потребностям.
- Приемлемые сроки поставки, возможна ускоренная поставка.
- Доставку товара в любую точку России и стран СНГ.
- Комплексную поставку.
- Работу по проектам и поставку образцов.
- Формирование склада под заказчика.
- Сертификаты соответствия на поставляемую продукцию (по желанию клиента).
- Тестирование поставляемой продукции.
- Поставку компонентов, требующих военную и космическую приемку.
- Входной контроль качества.
- Наличие сертификата ISO.

В составе нашей компании организован Конструкторский отдел, призванный помогать разработчикам, и инженерам.

Конструкторский отдел помогает осуществить:

- Регистрацию проекта у производителя компонентов.
- Техническую поддержку проекта.
- Защиту от снятия компонента с производства.
- Оценку стоимости проекта по компонентам.
- Изготовление тестовой платы монтаж и пусконаладочные работы.



Тел: +7 (812) 336 43 04 (многоканальный)  
Email: [org@lifeelectronics.ru](mailto:org@lifeelectronics.ru)