

General Description

The 8T73S208B-01 is a high-performance differential LVPECL clock divider and fanout buffer. The device is designed for the frequency division and signal fanout of high-frequency, low phase-noise clocks. The 8T73S208B-01 is characterized to operate from a 2.5V and 3.3V power supply. Guaranteed output-to-output and part-to-part skew characteristics make the 8T73S208B-01 ideal for those clock distribution applications demanding well-defined performance and repeatability. The integrated input termination resistors make interfacing to the reference source easy and reduce passive component count. Each output can be individually enabled or disabled in the high-impedance state controlled by a I²C register. On power-up, all outputs are disabled.

Features

- One differential input reference clock
- Differential pair can accept the following differential input levels: LVDS, LVPECL, CML
- Integrated input termination resistors
- Eight LVPECL outputs
- Selectable clock frequency division of ÷1, ÷2, ÷4 and ÷8
- Maximum input clock frequency: 1GHz
- LVCMOS interface levels for the control inputs
- Individual output enable/disabled by I²C interface
- Power-up state: all outputs disabled
- Output skew: 60ps (maximum)
- Output rise/fall times: 350ps (maximum)
- Low additive phase jitter, RMS: 182fs (typical)
- Full 2.5V and 3.3V supply voltages
- Lead-free (RoHS 6) 32-Lead VFQFN packaging
- -40°C to 85°C ambient operating temperature

Block Diagram

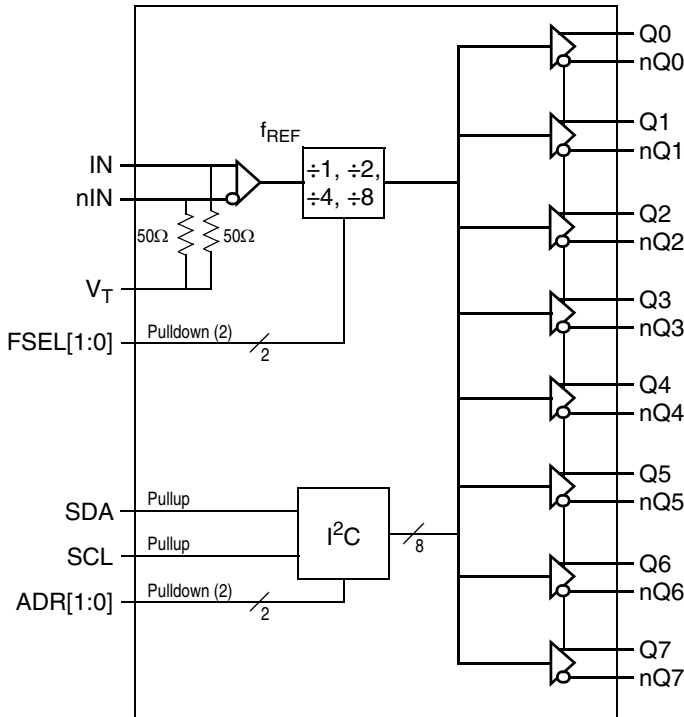

Pin Assignment

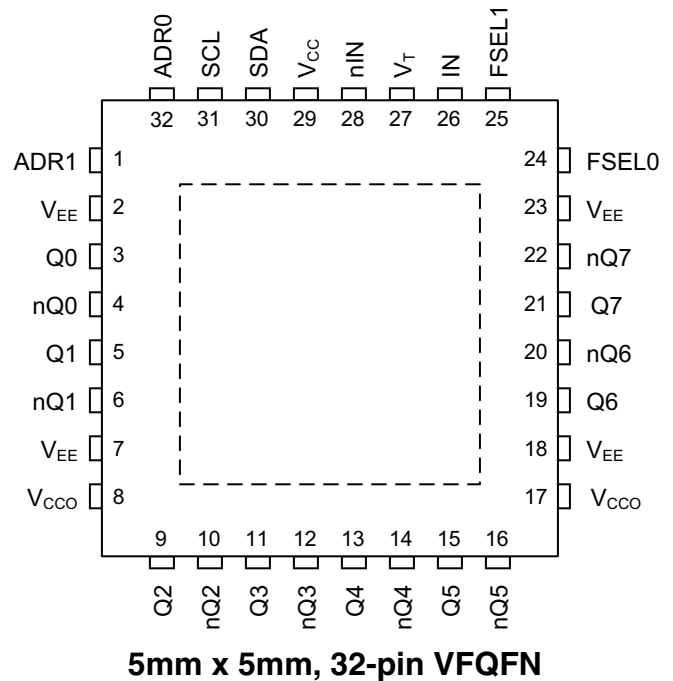

Pin Descriptions and Pin Characteristics

Table 1. Pin Descriptions

Number	Name	Type		Description
1, 32	ADR1, ADR0	Input	Pulldown	I ² C Address inputs. LVCMOS/LVTTL interface levels.
2, 7, 18, 23	V _{EE}	Power		Negative supply pins.
3, 4	Q0, nQ0	Output		Differential output pair 0. LVPECL interface levels.
5, 6	Q1, nQ1	Output		Differential output pair 1. LVPECL interface levels.
8, 17	V _{CCO}	Power		Output supply pins.
9, 10	Q2, nQ2	Output		Differential output pair 2. LVPECL interface levels.
11, 12	Q3, nQ3	Output		Differential output pair 3. LVPECL interface levels.
13, 14	Q4, nQ4	Output		Differential output pair 4. LVPECL interface levels.
15, 16	Q5, nQ5	Output		Differential output pair 5. LVPECL interface levels.
19, 20	Q6, nQ6	Output		Differential output pair 6. LVPECL interface levels.
21, 22	Q7, nQ7	Output		Differential output pair 7. LVPECL interface levels.
24, 25	FSEL0, FSEL1	Input	Pulldown	Frequency divider select controls. See Table 3A for function. LVCMOS/LVTTL interface levels.
26	IN	Input		Non-inverting differential clock input. RT = 50Ω termination to V _T .
27	V _T	Termination Input		Input for termination. Both IN and nIN inputs are internally terminated 50Ω to this pin. See input termination information in Section, "Applications Information" .
28	nIN	Input		Inverting differential clock input. RT = 50Ω termination to V _T .
29	V _{CC}	Power		Power supply pin.
30	SDA	I/O	Pullup	I ² C Data Input/Output. Input: LVCMOS/LVTTL interface levels. Output: open drain.
31	SCL	Input	Pullup	I ² C Clock Input. LVCMOS/LVTTL interface levels.

NOTE: *Pulldown* and *Pullup* refers to an internal input resistors. See [Section, "Table 2. Pin Characteristics"](#) values.

Table 2. Pin Characteristics

Symbol	Parameter	Test Conditions	Minimum	Typical	Maximum	Units
C _{IN}	Input Capacitance			2		pF
R _{PULLDOWN}	Input Pulldown Resistor			51		kΩ
R _{PULLUP}	Input Pullup Resistor			51		kΩ

Function Tables

Input Frequency Divider Operation

The FSEL1 and FSEL0 control pins configure the input frequency divider. In the default state (FSEL[1:0] are set to logic 0:0 or left open) the output frequency is equal to the input frequency (divide-by-1). The other FSEL[1:0] settings configure the input divider to divide-by-2, 4 or 8, respectively.

Table 3A. FSEL[1:0] Input Selection Function Table

Input		Operation
FSEL1	FSEL0	
0 (default)	0 (default)	$f_{Q[7:0]} = f_{REF} \div 1$
0	1	$f_{Q[7:0]} = f_{REF} \div 2$
1	0	$f_{Q[7:0]} = f_{REF} \div 4$
1	1	$f_{Q[7:0]} = f_{REF} \div 8$

NOTE: FSEL1, FSEL0 are asynchronous controls

Output Enable Operation

The output enable/disable state of each individual differential output Qx, nQx can be set by the content of the I²C register (see Table 3C). A logic zero to an I²C bit in register 0 enables the corresponding differential output, while a logic one disables the differential output (see Table 3B). After each power cycle, the device resets all I²C bits (Dn) to its default state (logic 1) and all Qx, nQx outputs are disabled. After the first valid I²C write, the output enable state is controlled by the I²C register. Setting and changing the output enable state through the I²C interface is asynchronous to the input reference clock.

Table 3B. Individual Output Enable Control

Bit	Operation
Dn	
0	Output Qx, nQx is enabled.
1 (default)	Output Qx, nQx is disabled in high-impedance state.

Table 3C. Individual output enable control

Bit	D7	D6	D5	D4	D3	D2	D1	D0
Output	Q7	Q6	Q5	Q4	Q3	Q2	Q1	Q0
Default	1	1	1	1	1	1	1	1

I²C Interface Protocol

The 8T73S208B-01 uses an I²C slave interface for writing and reading the device configuration to and from the on-chip configuration registers. This device uses the standard I²C write format for a write transaction, and a standard I²C read format for a read transaction. Figure 1 defines the I²C elements of the standard I²C transaction. These elements consist of a start bit, data bytes, an acknowledge or Not-Acknowledge bit and the stop bit. These elements are arranged to make up the complete I²C transactions as shown in Figure 2 and Figure 3. Figure 2 is a write transaction while Figure 3 is read transaction. The 7-bit I²C slave address of the 8T73S208B-01 is a combination of a 5-bit fixed addresses and two

variable bits which are set by the hardware pins ADR[1:0] (binary 11010, ADR1, ADR0). Bit 0 of slave address is used by the bus controller to select either the read or write mode. The hardware pins ADR1 and ADR0 and should be individually set by the user to avoid address conflicts of multiple 8T73S208B-01 devices on the same bus.

Table 3D. I²C Slave Address

7	6	5	4	3	2	1	0
1	1	0	1	0	ADR1	ADR0	R/W

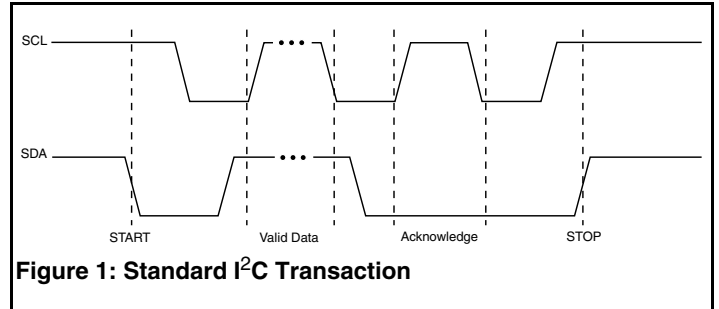

Figure 1: Standard I²C Transaction

START (S) – defined as high-to-low transition on SDA while holding SCL HIGH.

DATA – between START and STOP cycles, SDA is synchronous with SCL. Data may change only when SCL is LOW and must be stable when SCL is HIGH.

ACKNOWLEDGE (A) – SDA is driven LOW before the SCL rising edge and held LOW until the SCL falling edge.

STOP (S) – defined as low-to-high transition on SDA while holding SCL HIGH



Figure 2: Write Transaction

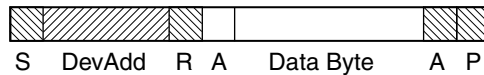

Figure 3: Read Transaction

- S** – Start or Repeated Start
- W** – R/W is set for Write
- R** – R/W is set for Read
- A** – Ack
- DevAdd** – 7 bit Device Address
- P** – Stop

Absolute Maximum Ratings

NOTE: Stresses beyond those listed under *Absolute Maximum Ratings* may cause permanent damage to the device. These ratings are stress specifications only. Functional operation of the product at these conditions or any conditions beyond those listed in the *DC Characteristics* or *AC Characteristics* is not implied. Exposure to absolute maximum rating conditions for extended periods may affect product reliability.

Item	Rating
Supply Voltage, V_{CC}	4.6V
Inputs, V_I	-0.5V to $V_{CC} + 0.5V$
Input Termination Current, I_{VT}	$\pm 35mA$
Outputs, I_O (LVPECL) Continuous Current Surge Current	50mA 100mA
Storage Temperature, T_{STG}	-65°C to 150°C
Maximum Junction Temperature, T_{JMAX}	125°C
ESD - Human Body Model ¹	2000V
ESD - Charged Device Model	500V

NOTE 1: According to JEDEC/JS-001-2012/JESD22-C101E.

DC Electrical Characteristics

Table 4A. Power Supply DC Characteristics, $V_{CC} = V_{CCO} = 2.5V \pm 5\%$ or $3.3V \pm 5\%$, $V_{EE} = 0V$, $T_A = -40^\circ C$ to $85^\circ C$

Symbol	Parameter	Test Conditions	Minimum	Typical	Maximum	Units
V_{CC}	Power Supply Voltage		2.375	2.5V	2.625	V
V_{CC}	Power Supply Voltage		3.135	3.3V	3.465	V
V_{CCO}	Output Supply Voltage		2.375	2.5V	2.625	V
V_{CCO}	Output Supply Voltage		3.135	3.3V	3.465	V
I_{EE}	Power Supply Current			92	110	mA

Table 4B. LVCMOS/LVTTL Input DC Characteristics, $V_{CC} = V_{CCO} = 2.5V \pm 5\%$ or $3.3V \pm 5\%$, $V_{EE} = 0V$, $T_A = -40^\circ C$ to $85^\circ C$

Symbol	Parameter	Test Conditions	Minimum	Typical	Maximum	Units	
V_{IH}	Input High Voltage ¹	FSEL[1:0], ADR[1:0]	$V_{CC} = 3.3V \pm 5\%$	2.2		$V_{CC} + 0.3V$	V
		SCL, SDA	$V_{CC} = 3.3V \pm 5\%$	2.4		$V_{CC} + 0.3V$	V
		FSEL[1:0], ADR[1:0]	$V_{CC} = 2.5V \pm 5\%$	1.7		$V_{CC} + 0.3V$	V
		SCL, SDA	$V_{CC} = 2.5V \pm 5\%$	1.9		$V_{CC} + 0.3V$	V
V_{IL}	Input Low Voltage ¹	FSEL[1:0], ADR[1:0]	$V_{CC} = 3.3V \pm 5\%$	-0.3		0.8	V
		SCL, SDA	$V_{CC} = 3.3V \pm 5\%$	-0.3		0.8	V
		FSEL[1:0], ADR[1:0]	$V_{CC} = 2.5V \pm 5\%$	-0.3		0.7	V
		SCL, SDA	$V_{CC} = 2.5V \pm 5\%$	-0.3		0.5	V
I_{IH}	Input High Current	FSEL[1:0], ADR[1:0]	$V_{CC} = V_{IN} = 2.625$ or $3.465V$		150	μA	
		SCL, SDA	$V_{CC} = V_{IN} = 2.625$ or $3.465V$		10	μA	
I_{IL}	Input Low Current	FSEL[1:0], ADR[1:0]	$V_{CC} = 2.625$ or $3.465V$, $V_{IN} = 0V$	-10		μA	
		SCL, SDA	$V_{CC} = 2.625$ or $3.465V$, $V_{IN} = 0V$	-150		μA	

NOTE 1: V_{IL} should not be lower than $-0.3V$ and V_{IH} should not be higher than $V_{CC} + 0.3V$.

Table 4C. Differential Input DC Characteristics, $V_{CC} = V_{CCO} = 2.5V \pm 5\%$ or $3.3V \pm 5\%$, $V_{EE} = 0V$, $T_A = -40^\circ C$ to $85^\circ C$

Symbol	Parameter	Test Conditions	Minimum	Typical	Maximum	Units
V_{IN}	Input Voltage Swing ¹	IN, nIN	0.15		1.2	V
V_{CMR}	Common Mode Input Voltage ^{1, 2}		1.2		$V_{CC} - (V_{IN}/2)$	V
V_{DIFF_IN}	Differential Input Voltage Swing		0.3		2.4	V
R_{IN}	Input Resistance	IN, nIN	IN, nIN to V_T		60	Ω
R_{IN_DIFF}	Differential Input Resistance	IN, nIN	IN to nIN, $V_T = \text{Open}$		120	Ω

NOTE 1: V_{IL} should not be less than $-0.3V$ and V_{IH} should not be greater than V_{CC}

NOTE 2: *Common Mode Input Voltage* is defined as the cross point.

Table 4D. LVPECL DC Characteristics, $V_{CC} = V_{CCO} = 3.3V \pm 5\%$, $V_{EE} = 0V$, $T_A = -40^\circ\text{C}$ to 85°C

Symbol	Parameter	Test Conditions	Minimum	Typical	Maximum	Units
V_{OH}	Output High Voltage ¹		$V_{CCO} - 1.102$	$V_{CCO} - 0.95$	$V_{CCO} - 0.775$	V
V_{OL}	Output Low Voltage ¹		$V_{CCO} - 1.802$	$V_{CCO} - 1.6$	$V_{CCO} - 1.367$	V
V_{SWING}	Peak-to-Peak Output Voltage Swing		0.6	0.7	1.0	V

 NOTE 1: Outputs terminated with 50Ω to $V_{CCO} - 2V$.

Table 4E. LVPECL DC Characteristics, $V_{CC} = V_{CCO} = 2.5V \pm 5\%$, $V_{EE} = 0V$, $T_A = -40^\circ\text{C}$ to 85°C

Symbol	Parameter	Test Conditions	Minimum	Typical	Maximum	Units
V_{OH}	Output High Voltage ¹		$V_{CCO} - 1.125$	$V_{CCO} - 0.95$	$V_{CCO} - 0.767$	V
V_{OL}	Output Low Voltage		$V_{CCO} - 1.799$	$V_{CCO} - 1.6$	$V_{CCO} - 1.359$	V
V_{SWING}	Peak-to-Peak Output Voltage Swing		0.60	0.65	1.00	V

 NOTE 1: Outputs terminated with 50Ω to $V_{CCO} - 2V$.

AC Electrical Characteristics

Table 5. AC Electrical Characteristics, $V_{CC} = V_{CCO} = 2.5V \pm 5\%$ or $3.3V \pm 5\%$, $T_A = -40^\circ C$ to $85^\circ C$

Symbol	Parameter ¹		Test Conditions	Minimum	Typical	Maximum	Units
f_{REF}	Input Frequency	IN, nIN				1	GHz
f_{SCL}	I ² C Clock Frequency					400	kHz
t_{JIT}	Buffer Additive Phase Jitter, RMS; refer to Additive Phase Jitter Section, measured with FSEL[1:0] = 00		$f_{REF} = 156.25MHz$, Integration Range: 12kHz – 20MHz		182	207	fs
t_{PD}	Propagation Delay ²	IN, nIN to Qx, nQx	FSEL[1:0] = 00	350		750	ps
			FSEL[1:0] = 01	500		870	ps
			FSEL[1:0] = 10	550		1052	ps
			FSEL[1:0] = 11	650		1230	ps
$t_{sk(o)}$	Output Skew ^{3, 4}				60	ps	
$t_{sk(p)}$	Pulse Skew				50	ps	
$t_{sk(pp)}$	Part-to-Part Skew ^{3, 5, 6}				500	ps	
odc	Output Duty Cycle ⁷		Any Frequency		50		%
			at $f_{REF} = 100MHz$	48	50	52	%
			at $f_{REF} = 125MHz$	48	50	52	%
			at $f_{REF} = 156.25MHz$	48	50	52	%
t_{PDZ}	Output Enable and Disable Time ⁸		Output Enable/ Disable State from/ to Active/ Inactive		1		μs
t_R / t_F	Output Rise/Fall Time		20% to 80%		140	205	ps
			10% to 90%		180	350	ps

NOTE 1: Electrical parameters are guaranteed over the specified ambient operating temperature range, which is established when the device is mounted in a test socket with maintained transverse airflow greater than 500 lfm. The device will meet specifications after thermal equilibrium has been reached under these conditions.

NOTE 2: Measured from the differential input crossing point to the differential output cross point.

NOTE 3: Defined as skew between outputs at the same supply voltage and with equal load conditions. Measured at the differential cross point.

NOTE 4: This parameter is defined in accordance with JEDEC Standard 65.

NOTE 5: Defined as skew between outputs on different devices operating at the same supply voltage, same temperature, same frequency and with equal load conditions. Using the same type of inputs on each device, the outputs are measured at the differential cross point.

NOTE 6: Part-to-part skew specification does not guarantee divider synchronization among devices.

NOTE 7: If FSEL[1:0] = 00 (divide-by-one), the output duty cycle will depend on the input duty cycle.

NOTE 8: Measured from SDA rising edge of I²C stop command.

Additive Phase Jitter

The spectral purity in a band at a specific offset from the fundamental compared to the power of the fundamental is called the **dBc Phase Noise**. This value is normally expressed using a Phase noise plot and is most often the specified plot in many applications. Phase noise is defined as the ratio of the noise power present in a 1Hz band at a specified offset from the fundamental frequency to the power value of the fundamental. This ratio is expressed in decibels (dBm) or a ratio

of the power in the 1Hz band to the power in the fundamental. When the required offset is specified, the phase noise is called a **dBc** value, which simply means dBm at a specified offset from the fundamental. By investigating jitter in the frequency domain, we get a better understanding of its effects on the desired application over the entire time record of the signal. It is mathematically possible to calculate an expected bit error rate given a phase noise plot.

Typical Phase Jitter at 156.25MHz

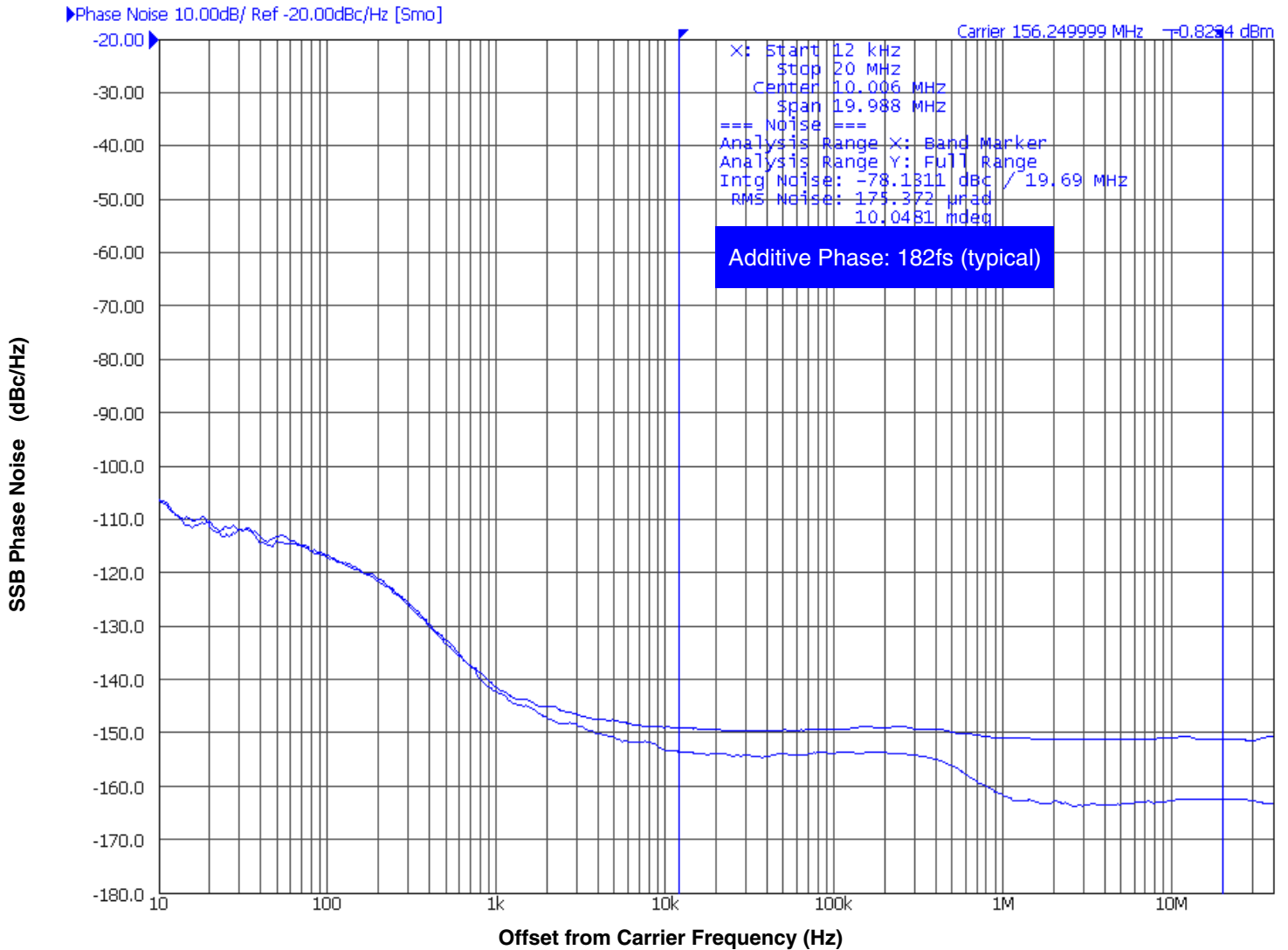

The input source is 156.25MHz Wenzel Oscillator.

Parameter Measurement Information

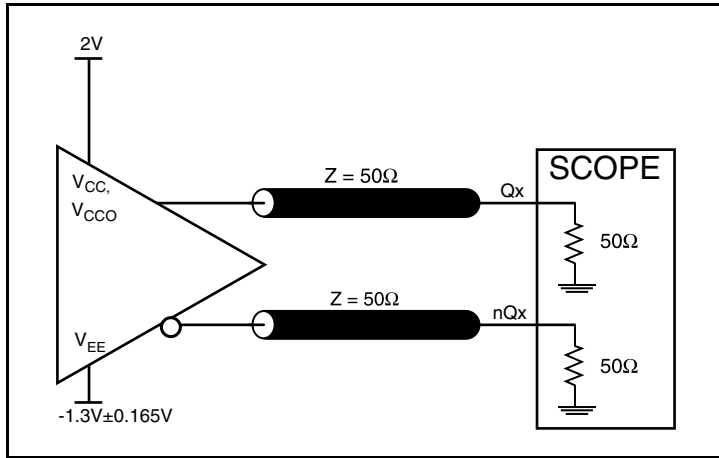

3.3 Core/3.3V LVPECL Output Load AC Test Circuit

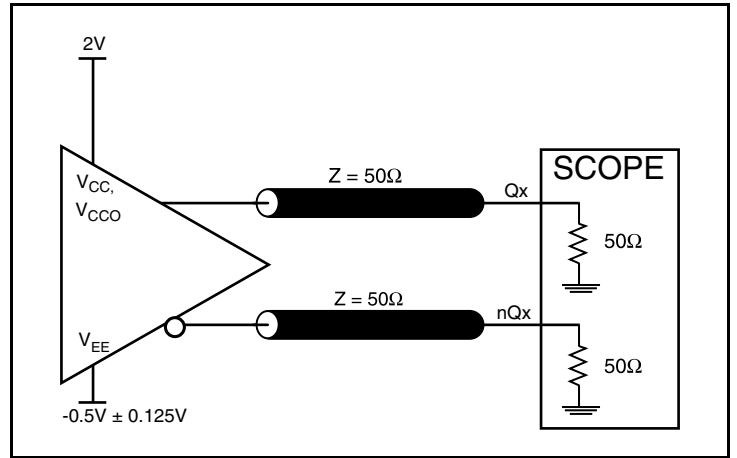

2.5V Core/2.5V LVPECL Output Load AC Test Circuit

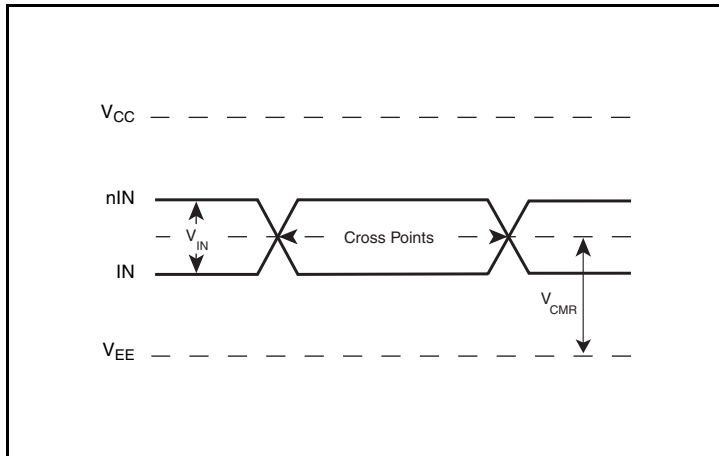

Differential Input Level

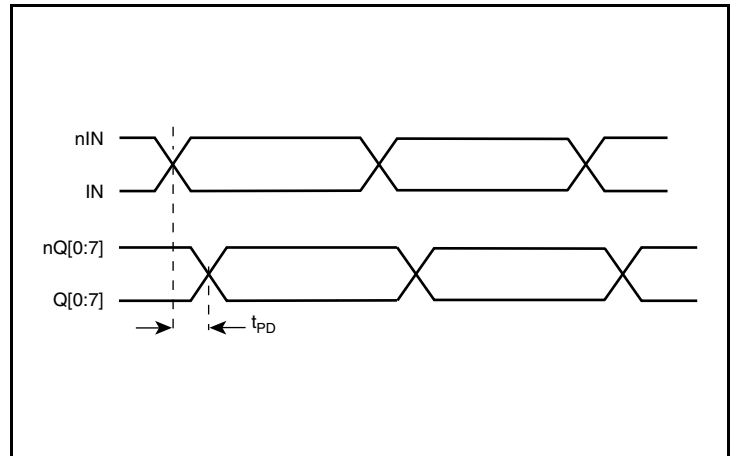

Propagation Delay

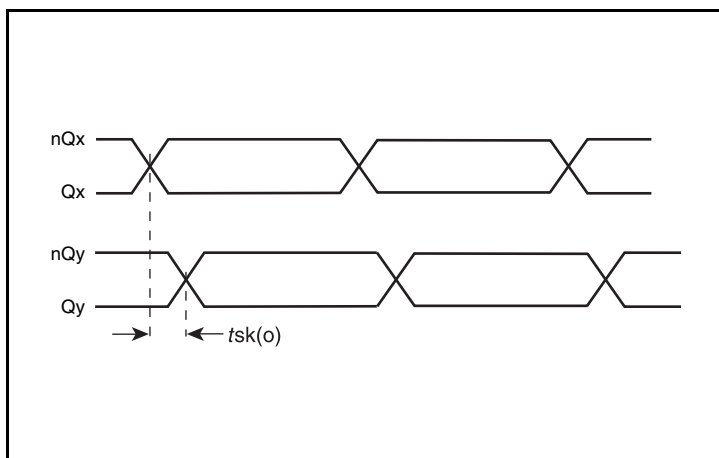

Output Skew

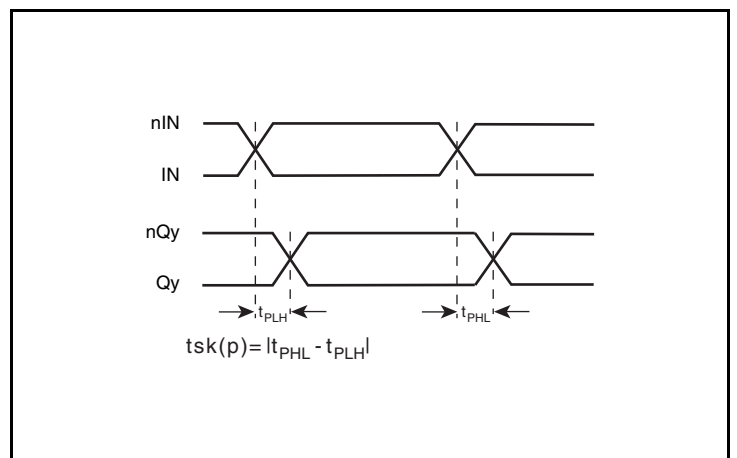

Pulse Skew

Parameter Measurement Information, continued

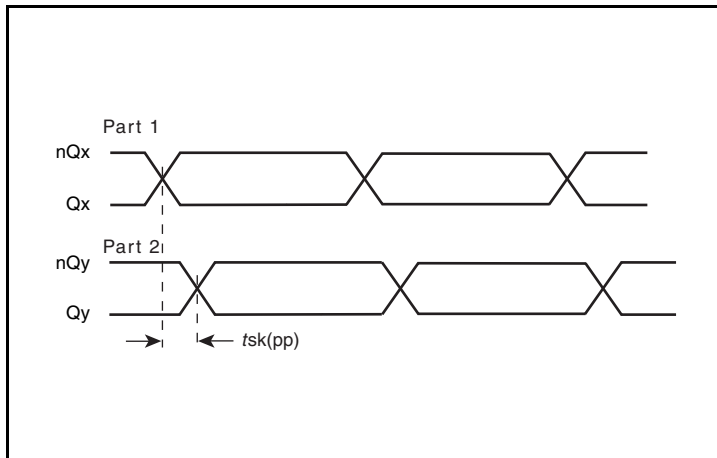

Part-to-Part Skew

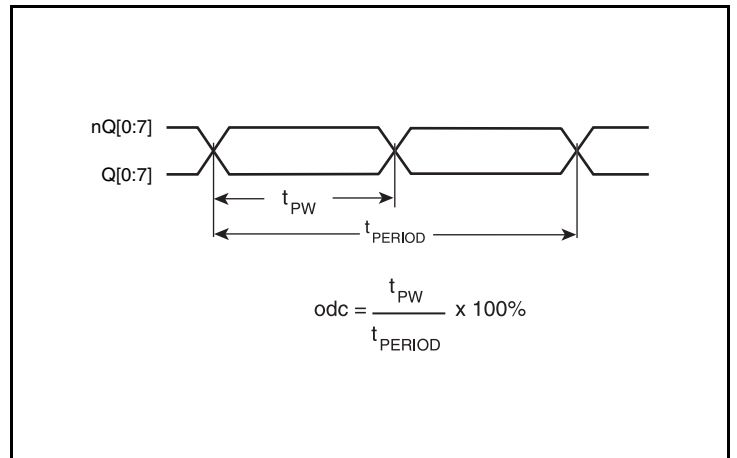

Output Duty Cycle/Pulse Width/Period

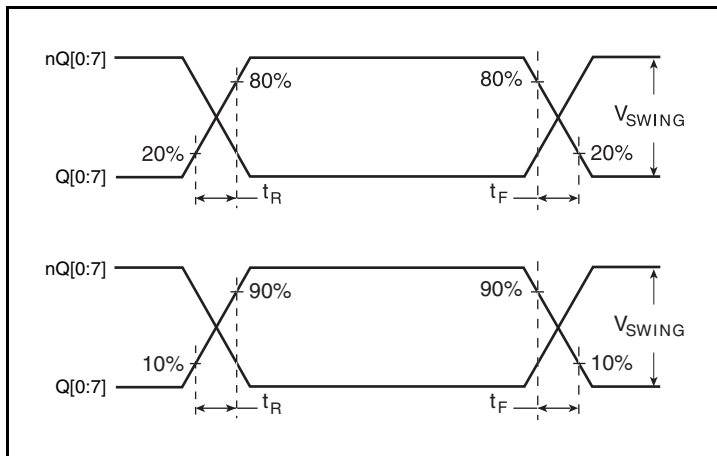

Output Rise/Fall Times

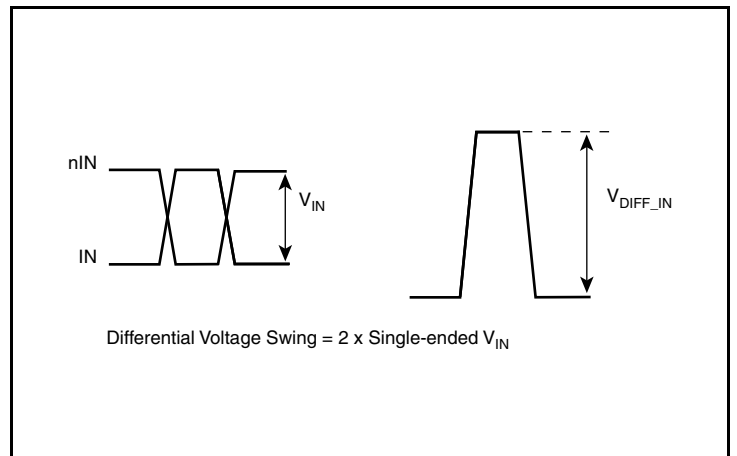

Single-Ended & Differential Input Voltage Swing

Applications Information

3.3V Differential Input with Built-In 50Ω Termination Interface

The IN/nIN with built-in 50Ω terminations accept LVDS, LVPECL, CML and other differential signals. Both signals must meet the V_{IN} and V_{CMR} input requirements. *Figures 4A to 4C* show interface examples for the IN/nIN input with built-in 50Ω terminations driven by

the most common driver types. The input interfaces suggested here are examples only. If the driver is from another vendor, use their termination recommendation. Please consult with the vendor of the driver component to confirm the driver termination requirements.

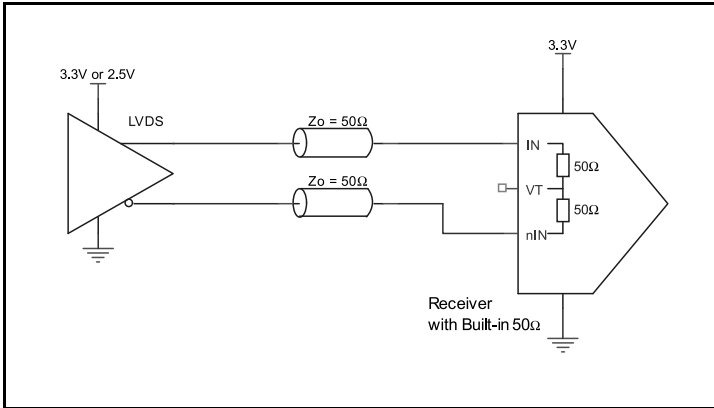

Figure 4A. IN/nIN Input with Built-In 50Ω Driven by an LVDS Driver

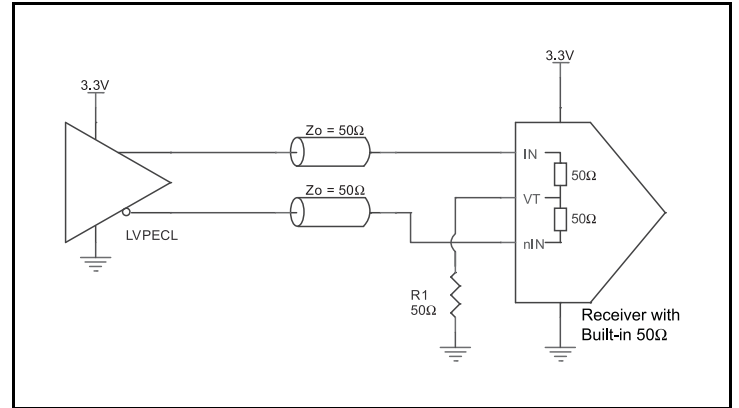

Figure 4B. IN/nIN Input with Built-In 50Ω Driven by an LVPECL Driver

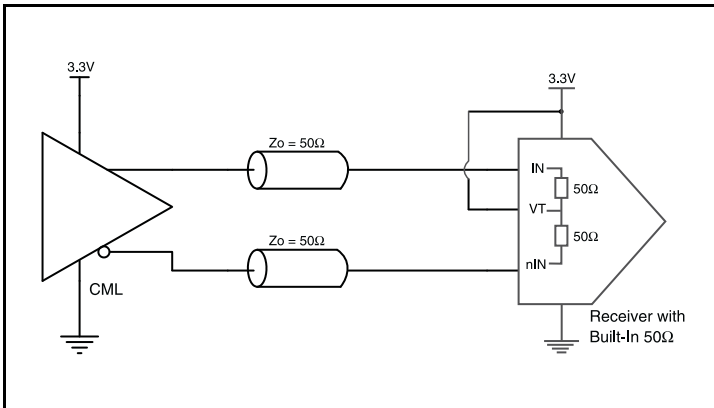

Figure 4C. IN/nIN Input with Built-In 50Ω Driven by a CML Driver

2.5V LVPECL Input with Built-In 50Ω Termination Interface

The IN/nIN with built-in 50Ω terminations accept LVDS, LVPECL, CML and other differential signals. Both signals must meet the V_{IN} and V_{CMR} input requirements. *Figures 5A to 5C* show interface examples for the IN/nIN with built-in 50Ω termination input driven by

the most common driver types. The input interfaces suggested here are examples only. If the driver is from another vendor, use their termination recommendation. Please consult with the vendor of the driver component to confirm the driver termination requirements.

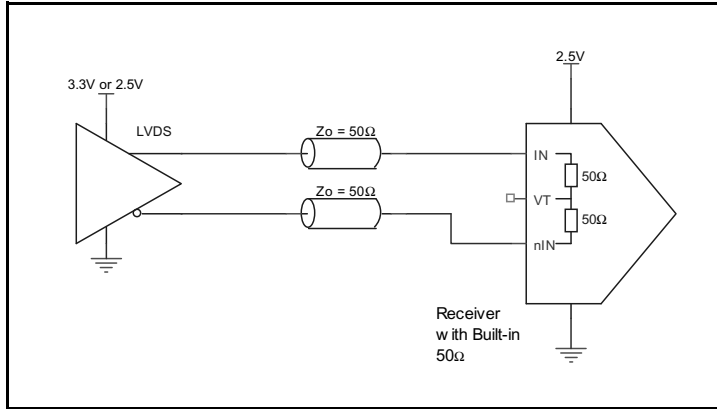

Figure 5A. IN/nIN Input with Built-In 50Ω Driven by an LVDS Driver

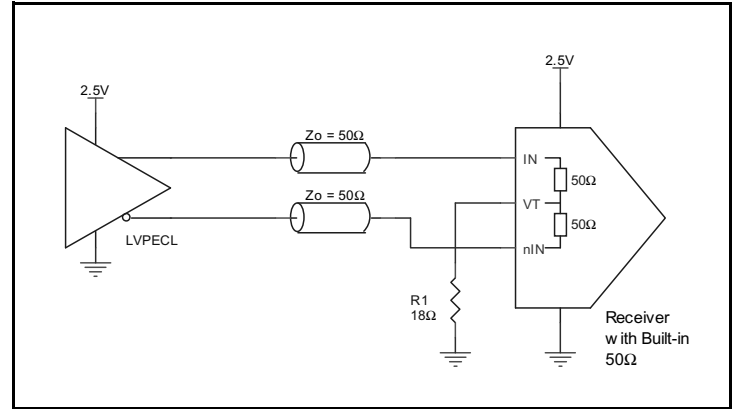

Figure 5B. IN/nIN Input with Built-In 50Ω Driven by an LVPECL Driver

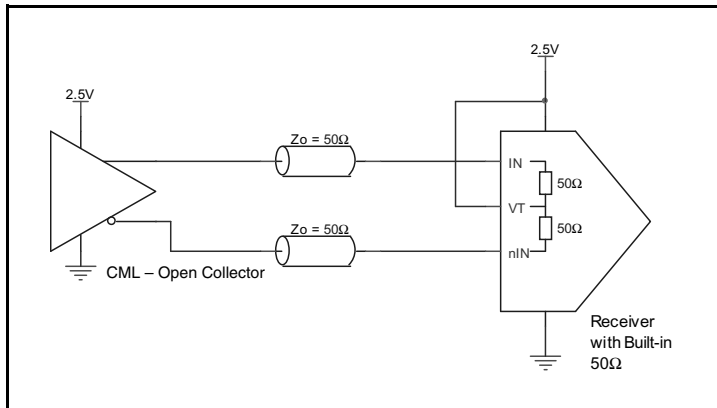

Figure 5C. IN/nIN Input with Built-In 50Ω Driven by a CML Driver

VFQFN EPAD Thermal Release Path

In order to maximize both the removal of heat from the package and the electrical performance, a land pattern must be incorporated on the Printed Circuit Board (PCB) within the footprint of the package corresponding to the exposed metal pad or exposed heat slug on the package, as shown in *Figure 6*. The solderable area on the PCB, as defined by the solder mask, should be at least the same size/shape as the exposed pad/slug area on the package to maximize the thermal/electrical performance. Sufficient clearance should be designed on the PCB between the outer edges of the land pattern and the inner edges of pad pattern for the leads to avoid any shorts.

While the land pattern on the PCB provides a means of heat transfer and electrical grounding from the package to the board through a solder joint, thermal vias are necessary to effectively conduct from the surface of the PCB to the ground plane(s). The land pattern must be connected to ground through these vias. The vias act as “heat pipes”. The number of vias (i.e. “heat pipes”) are application specific

and dependent upon the package power dissipation as well as electrical conductivity requirements. Thus, thermal and electrical analysis and/or testing are recommended to determine the minimum number needed. Maximum thermal and electrical performance is achieved when an array of vias is incorporated in the land pattern. It is recommended to use as many vias connected to ground as possible. It is also recommended that the via diameter should be 12 to 13mils (0.30 to 0.33mm) with 1oz copper via barrel plating. This is desirable to avoid any solder wicking inside the via during the soldering process which may result in voids in solder between the exposed pad/slug and the thermal land. Precautions should be taken to eliminate any solder voids between the exposed heat slug and the land pattern. Note: These recommendations are to be used as a guideline only. For further information, please refer to the Application Note on the Surface Mount Assembly of Amkor’s Thermally/ Electrically Enhance Lead frame Base Package, Amkor Technology.

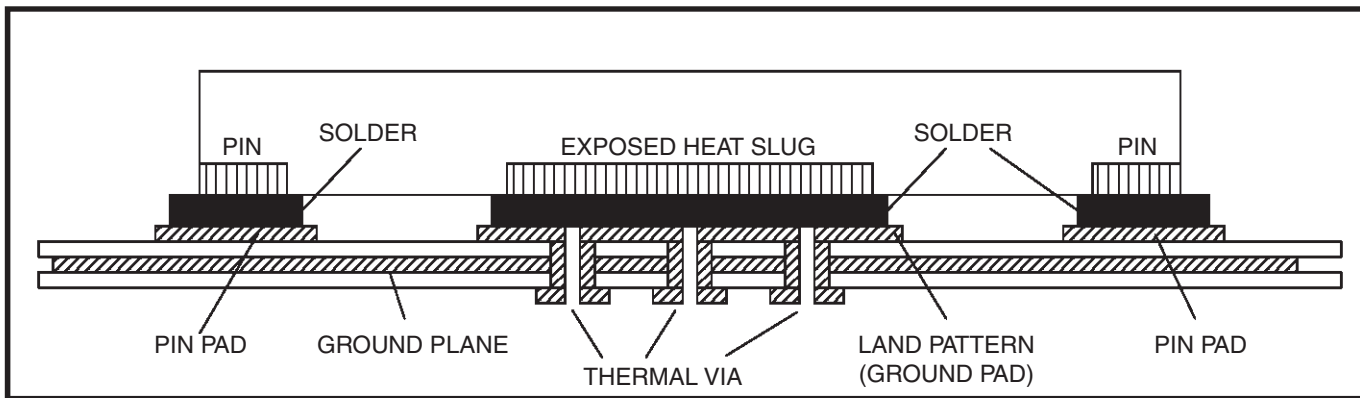

Figure 6. P.C. Assembly for Exposed Pad Thermal Release Path – Side View (drawing not to scale)

Recommendations for Unused Input and Output Pins

Inputs:

LVCMOS Control Pins

All control pins have internal pull-ups or pull-downs; additional resistance is not required but can be added for additional protection. A 1kΩ resistor can be used.

Outputs:

LVPECL Outputs

Any unused LVPECL output pair can be left floating. We recommend that there is no trace attached.

Termination for 3.3V LVPECL Outputs

Figures 7A and 7B are examples of 3.3V LVPECL output DC terminations.

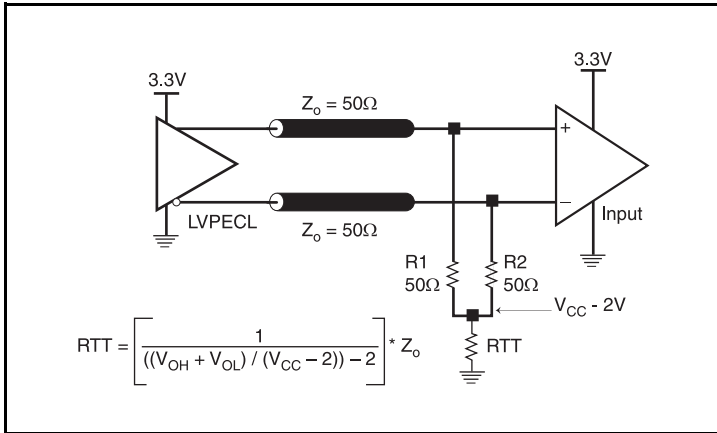

Figure 7A. 3.3V LVPECL Output Termination

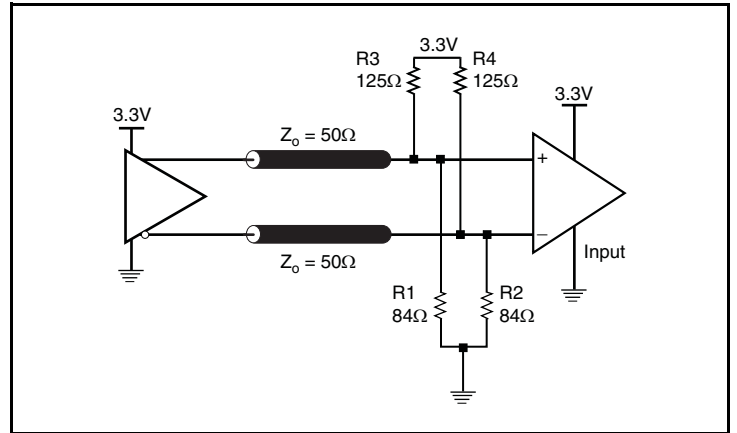

Figure 7B. 3.3V LVPECL Output Termination

Termination for 2.5V LVPECL Outputs

Figure 8A and Figure 8B show examples of termination for 2.5V LVPECL driver. These terminations are equivalent to terminating 50Ω to $V_{CC0} - 2V$. For $V_{CC0} = 2.5V$, the $V_{CC0} - 2V$ is very close to ground

level. The R3 in Figure 8B can be eliminated and the termination is shown in Figure 8C.

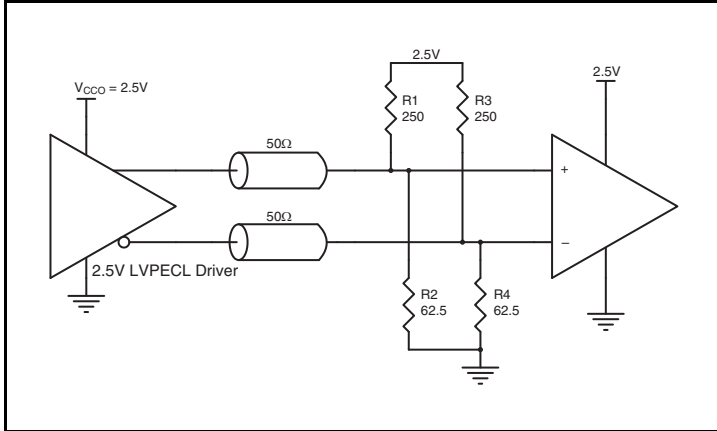

Figure 8A. 2.5V LVPECL Driver Termination Example

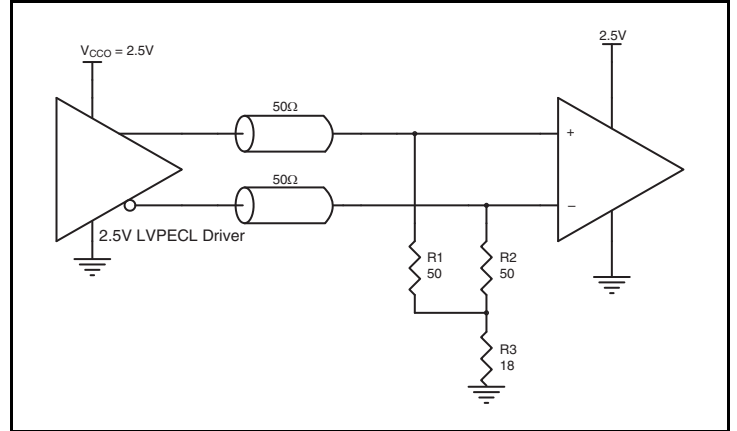

Figure 8B. 2.5V LVPECL Driver Termination Example

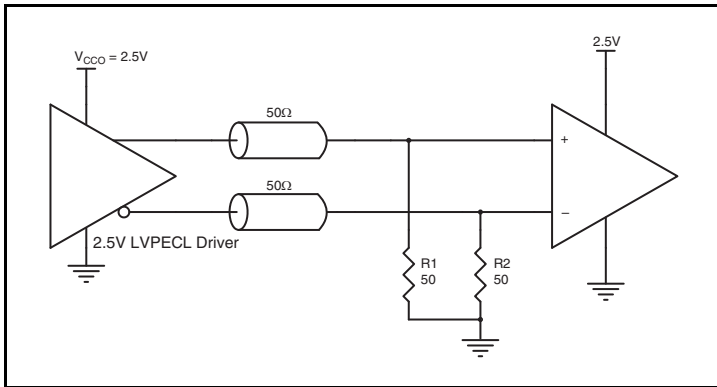

Figure 8C. 2.5V LVPECL Driver Termination Example

Power Considerations

This section provides information on power dissipation and junction temperature for the 8T73S208B-01. Equations and example calculations are also provided.

1. Power Dissipation.

The total power dissipation for the 8T73S208B-01 is the sum of the core power plus the power dissipated due to loading. The following is the power dissipation for $V_{CC} = 3.465V$, which gives worst case results.

NOTE: Refer to [Section, "3. Calculations and Equations."](#) for details on calculating power dissipated due to loading.

$$I_{EE_MAX} @ 85^{\circ}C = 106.52mA$$

- Power (core)_{MAX} = $V_{CC_MAX} * I_{EE_MAX} = 3.465V * 106.52mA = 369.09mW$
- Power (outputs)_{MAX} = **36.3mW/Loaded Output pair**
If all outputs are loaded, the total power is $8 * 36.3mW = 290.4mW$
- Power Dissipation for Internal Termination R_T with V_T floating
Power $(R_T)_{MAX} = (V_{IN_MAX})^2 / R_{T_MIN} = (1.2)^2 / 80 = 18mW$

$$\text{Total Power}_{MAX} = (3.465V, \text{ with all outputs switching}) = 369.09mW + 290.4mW + 18mW = 677.49mW$$

2. Junction Temperature.

Junction temperature, T_j , is the temperature at the junction of the bond wire and bond pad, and directly affects the reliability of the device. The maximum recommended junction temperature is $125^{\circ}C$. Limiting the internal transistor junction temperature, T_j , to $125^{\circ}C$ ensures that the bond wire and bond pad temperature remains below $125^{\circ}C$.

The equation for T_j is as follows: $T_j = \theta_{JA} * Pd_total + T_A$

T_j = Junction Temperature

θ_{JA} = Junction-to-Ambient Thermal Resistance

Pd_total = Total Device Power Dissipation (example calculation is in section 1 above)

T_A = Ambient Temperature

In order to calculate junction temperature, the appropriate junction-to-ambient thermal resistance θ_{JA} must be used. Assuming no air flow and a multi-layer board, the appropriate value is $42.7^{\circ}C/W$ per Table 6 below.

Therefore, T_j for an ambient temperature of $85^{\circ}C$ with all outputs switching is:

$$85^{\circ}C + 0.678W * 42.7^{\circ}C/W = 113.93^{\circ}C. \text{ This is below the limit of } 125^{\circ}C.$$

This calculation is only an example. T_j will obviously vary depending on the number of loaded outputs, supply voltage, air flow and the type of board (multi-layer).

Table 6. Thermal Resistance θ_{JA} for 32-Lead VFQFN, Forced Convection

θ_{JA} vs. Air Flow			
Meters per Second	0	1	2.5
Multi-Layer PCB, JEDEC Standard Test Boards	$42.7^{\circ}C/W$	$37.3^{\circ}C/W$	$33.5^{\circ}C/W$

3. Calculations and Equations.

The purpose of this section is to calculate the power dissipation for the LVPECL output pairs.

LVPECL output driver circuit and termination are shown in *Figure 9*.

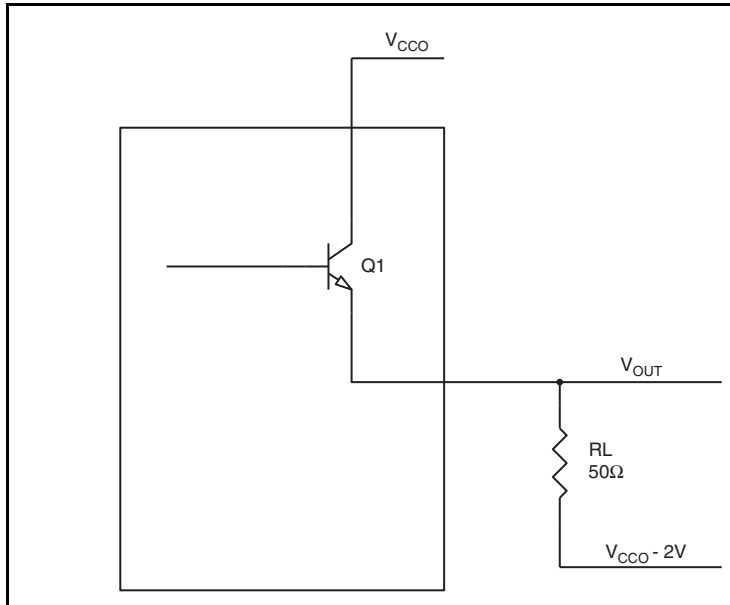

Figure 9. LVPECL Driver Circuit and Termination

To calculate power dissipation due to loading, use the following equations which assume a 50Ω load, and a termination voltage of $V_{CCO} - 2V$.

- For logic high, $V_{OUT} = V_{OH_MAX} = V_{CCO_MAX} - 0.775V$
 $(V_{CCO_MAX} - V_{OH_MAX}) = 0.775V$
- For logic low, $V_{OUT} = V_{OL_MAX} = V_{CCO_MAX} - 1.367V$
 $(V_{CCO_MAX} - V_{OL_MAX}) = 1.367V$

Pd_H is power dissipation when the output drives high.

Pd_L is the power dissipation when the output drives low.

$$Pd_H = [(V_{OH_MAX} - (V_{CCO_MAX} - 2V))/R_L] * (V_{CCO_MAX} - V_{OH_MAX}) = [(2V - (V_{CCO_MAX} - V_{OH_MAX}))/R_L] * (V_{CCO_MAX} - V_{OH_MAX}) = [(2V - 0.775V)/50\Omega] * 0.775V = \mathbf{18.99mW}$$

$$Pd_L = [(V_{OL_MAX} - (V_{CCO_MAX} - 2V))/R_L] * (V_{CCO_MAX} - V_{OL_MAX}) = [(2V - (V_{CCO_MAX} - V_{OL_MAX}))/R_L] * (V_{CCO_MAX} - V_{OL_MAX}) = [(2V - 1.367V)/50\Omega] * 1.367V = \mathbf{17.31mW}$$

Total Power Dissipation per output pair = $Pd_H + Pd_L = \mathbf{36.3mW}$

Reliability Information

Table 7. θ_{JA} vs. Air Flow Table for a 32-Lead VFQFN

θ_{JA} vs. Air Flow			
Meters per Second	0	1	2.5
Multi-Layer PCB, JEDEC Standard Test Boards	42.7°C/W	37.3°C/W	33.5°C/W

Transistor Count

The transistor count for 8T73S208B-01 is: 5153

32-Lead VFQFN Package Outline and Package Dimensions

REVISIONS			
REV	DESCRIPTION	DATE	APPROVED
00	INITIAL RELEASE	2/1/16	JH
01	ADD "k" VALUE MIN 0.20	2/8/16	JH

SYMBOL	DIMENSION		
	MIN	NOM	MAX
b	0.18	0.25	0.30
D	5.00 BSC		
E	5.00 BSC		
D2	3.00	3.15	3.30
E2	3.00	3.15	3.30
L	0.30	0.40	0.50
e	0.50 BSC		
N	32		
A	0.80	0.90	1.00
A1	0.00	0.02	0.05
A3	0.2 REF		
k	0.20	10.53 REF	

TOP VIEW

SIDE VIEW

BOTTOM VIEW

7/0.10E

PIN #1 ID OPTION

NOTES:

- ALL DIMENSIONS ARE IN mm. ANGLES IN DEGREES.
- COPLANARITY APPLIES TO THE EXPOSED PAD AS WELL AS THE TERMINALS.
- COPLANARITY SHALL NOT EXCEED 0.08 mm.
- WARPAGE SHALL NOT EXCEED 0.10 mm.

<p>TOLERANCES UNLESS SPECIFIED</p> <p>DECIMAL ±0.1</p> <p>XX±.05</p> <p>XXX±.030</p>	<p>6024 Silver Creek Valley Rd San Jose, CA 95138 PHONE: (408) 284-8200 FAX: (408) 284-3572</p> <p>www.IDT.com</p>	<p>TITLE NL/NLG 32 PACKAGE OUTLINE</p> <p>5.0 x 5.0 mm BODY EPAD 3.15 x 3.15</p> <p>0.50 mm PITCH QFN</p>
<p>APPROVALS</p> <p>DRAWN 024C</p> <p>CHECKED</p>	<p>DATE</p> <p>2/1/16</p>	<p>SIZE</p> <p>C</p>
<p>DRAWING No.</p> <p>PSC-4171-01</p>		<p>REV</p> <p>01</p>
<p>DO NOT SCALE DRAWING</p>		
		<p>SHEET 1 OF 2</p>

32-Lead VFQFN Package Outline and Package Dimensions, continued

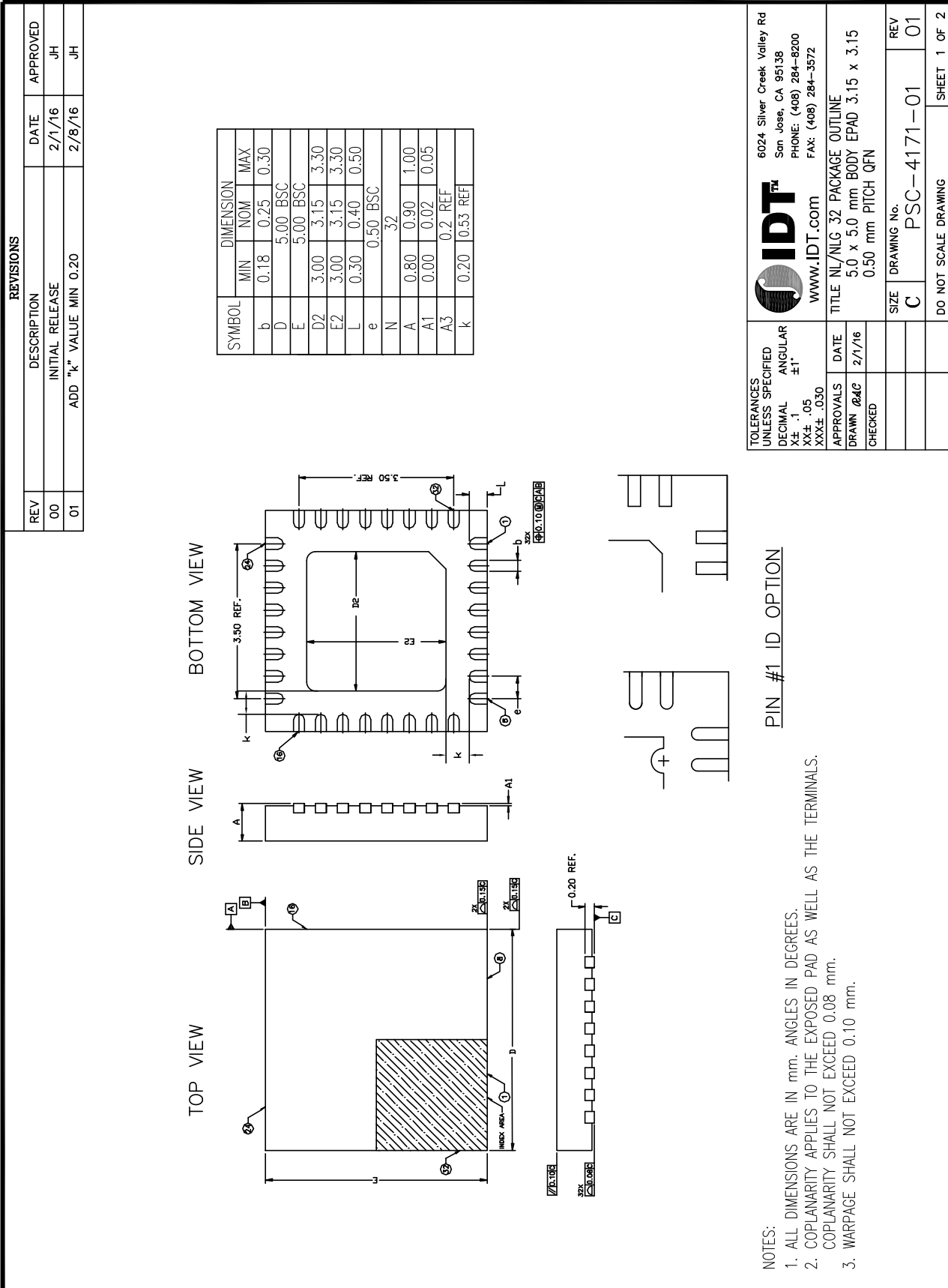

Ordering Information

Table 8. Ordering Information

Part/Order Number	Marking	Package	Shipping Packaging	Temperature
8T73S208B-01NLGI	IDT8T73S208B-01NLGI	"Lead-Free" 32-Lead VFQFN	Tray	-40°C to 85°C
8T73S208B-01NLGI8	IDT8T73S208B-01NLGI	"Lead-Free" 32-Lead VFQFN	Tape & Reel	-40°C to 85°C



Corporate Headquarters
6024 Silver Creek Valley Road
San Jose, CA 95138 USA
www.IDT.com

Sales
1-800-345-7015 or 408-284-8200
Fax: 408-284-2775
www.IDT.com/go/sales

Tech Support
www.idt.com/go/support

DISCLAIMER Integrated Device Technology, Inc. (IDT) reserves the right to modify the products and/or specifications described herein at any time, without notice, at IDT's sole discretion. Performance specifications and operating parameters of the described products are determined in an independent state and are not guaranteed to perform the same way when installed in customer products. The information contained herein is provided without representation or warranty of any kind, whether express or implied, including, but not limited to, the suitability of IDT's products for any particular purpose, an implied warranty of merchantability, or non-infringement of the intellectual property rights of others. This document is presented only as a guide and does not convey any license under intellectual property rights of IDT or any third parties.

IDT's products are not intended for use in applications involving extreme environmental conditions or in life support systems or similar devices where the failure or malfunction of an IDT product can be reasonably expected to significantly affect the health or safety of users. Anyone using an IDT product in such a manner does so at their own risk, absent an express, written agreement by IDT.

Integrated Device Technology, IDT and the IDT logo are trademarks or registered trademarks of IDT and its subsidiaries in the United States and other countries. Other trademarks used herein are the property of IDT or their respective third party owners.

For datasheet type definitions and a glossary of common terms, visit www.idt.com/go/glossary.

Copyright ©2016 Integrated Device Technology, Inc. All rights reserved.

Компания «Life Electronics» занимается поставками электронных компонентов импортного и отечественного производства от производителей и со складов крупных дистрибьюторов Европы, Америки и Азии.

С конца 2013 года компания активно расширяет линейку поставок компонентов по направлению коаксиальный кабель, кварцевые генераторы и конденсаторы (керамические, пленочные, электролитические), за счёт заключения дистрибьюторских договоров

Мы предлагаем:

- Конкурентоспособные цены и скидки постоянным клиентам.
- Специальные условия для постоянных клиентов.
- Подбор аналогов.
- Поставку компонентов в любых объемах, удовлетворяющих вашим потребностям.
- Приемлемые сроки поставки, возможна ускоренная поставка.
- Доставку товара в любую точку России и стран СНГ.
- Комплексную поставку.
- Работу по проектам и поставку образцов.
- Формирование склада под заказчика.
- Сертификаты соответствия на поставляемую продукцию (по желанию клиента).
- Тестирование поставляемой продукции.
- Поставку компонентов, требующих военную и космическую приемку.
- Входной контроль качества.
- Наличие сертификата ISO.

В составе нашей компании организован Конструкторский отдел, призванный помогать разработчикам, и инженерам.

Конструкторский отдел помогает осуществить:

- Регистрацию проекта у производителя компонентов.
- Техническую поддержку проекта.
- Защиту от снятия компонента с производства.
- Оценку стоимости проекта по компонентам.
- Изготовление тестовой платы монтаж и пусконаладочные работы.



Тел: +7 (812) 336 43 04 (многоканальный)
Email: org@lifeelectronics.ru