



TWR-WIFI-RS2101

User's Manual

Rev. 1.0

Contents

1 Overview	3
2 Reference Documents.....	4
3 Hardware Features.....	4
3.1 RS9110-N-11-21 Module.....	4
3.2 System Power.....	5
3.3 Access Header	5
3.4 Elevator Connections	5
3.5 Mechanical Form Factor	Error! Bookmark not defined.
4 Jumper Table	8

Revision History

Revision	Date	Changes
1.0	July 2010	Initial Release

1 Overview

The Redpine Wi-Fi Tower Module (TWR-WIFI-RS2101) is a low-cost evaluation, demonstration and development board that features an 802.11n solution from Redpine Signals. The following list summarizes the features of the TWR-WIFI-RS2101:

- RS9110-N-11-21 Wi-Fi module
 - Compliant to 802.11b/g and single stream 802.11n
 - Supports all Wi-Fi client security protocols (WEP, WPA, and WPA2)
 - Reference Design certified for FCC/IC/CE
 - RoHS compliant
 - Does not require any WLAN driver on the host processor
 - Host interface through SPI
 - Terminates SLIP connections and offers transparent serial modem functionality
 - Integrated antenna, frequency reference, and low-frequency clock
 - Ultra low power operation with power save modes
 - Single supply 3.1 to 3.6V operation

A block diagram for the TWR-WIFI-RS2101 is shown in the figure below.

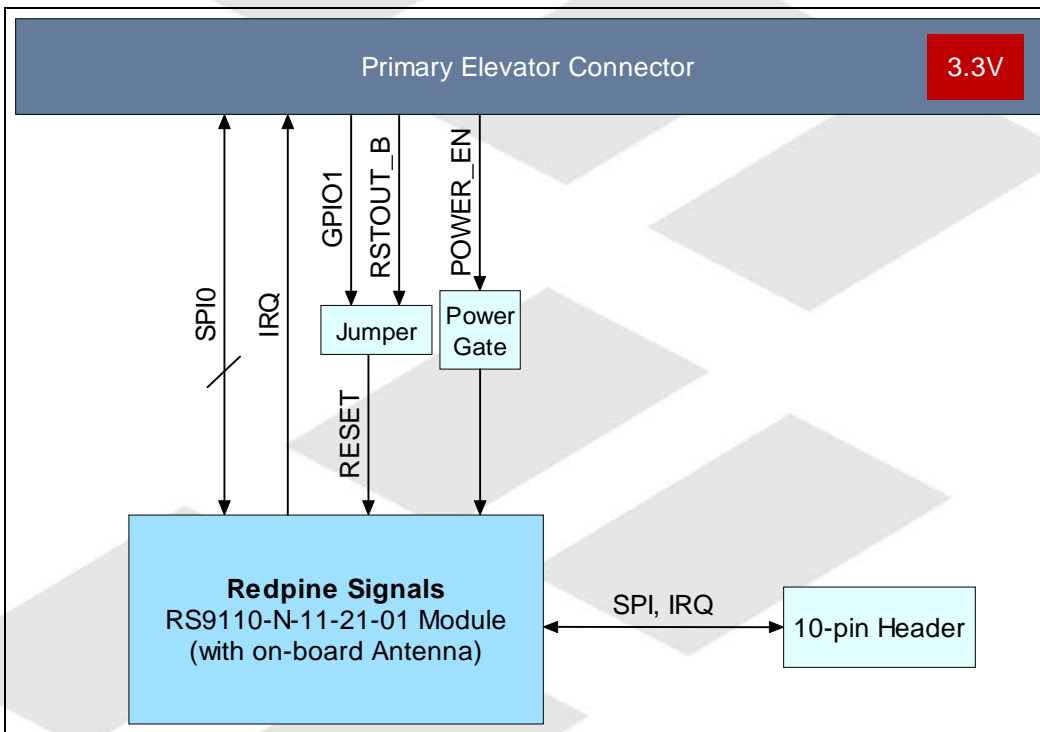

Figure 1. TWR-WIFI-RS2101 Block Diagram

2 Reference Documents

The documents listed below should be referenced for more information on the Freescale Tower system and the TWR-WIFI-RS2101. Refer to <http://www.freesale.com/tower> for the latest revision of all Tower documentation.

- *TWR-WIFI-RS2101 User Manual*
- *TWR-WIFI-RS2101 Quick Start Guide*
- *TWR-WIFI-RS2101 Lab Tutorial*
- *RS9110-N-11-21 Product Brief*
- *RS9110-N-11-21 Wi-Fi Module Abridged Datasheet*

3 Hardware Features

This section provides more details about the features and functionality of the TWR-WIFI-RS2101.

3.1 RS9110-N-11-21 Module

The RS9110-N-11-21 module from Redpine's Connect-io-n[™] family of products is a complete IEEE 802.11bgn Wi-Fi client device with a standard serial or SPI interface to a host processor or data source. It integrates a MAC, Baseband processor, RF transceiver with power amplifier, a frequency reference, an antenna, and all WLAN protocol and configuration functionality in embedded firmware to provide a self-contained 802.11n WLAN solution for a variety of applications. No WLAN driver functionality is required on the host processor. Based on the Redpine Signals RS9110 SoC which includes an embedded processor, it is designed to provide standards compliant wireless connectivity to devices and systems that have a serial port and implement a TCP/IP stack. As a wireless serial modem, the RS9110-N-11-21 handles SLIP packets and accepts AT commands for configuration, enabling a variety of M2M applications at low cost and small footprint. It uniquely provides connectivity in the single stream 802.11n mode, preserving overall network throughput in the emerging enterprise environments.

For the TWR-WIFI-RS2101 Tower Peripheral Module, the RS9110-N-11-21 module communicates with the MCU through an SPI.

Figure 2 shows a functional block diagram of the RS9110-N-11-21 module. Refer to the *RS9110-N-11-21 Wi-Fi Module Abridged Datasheet* for more information.

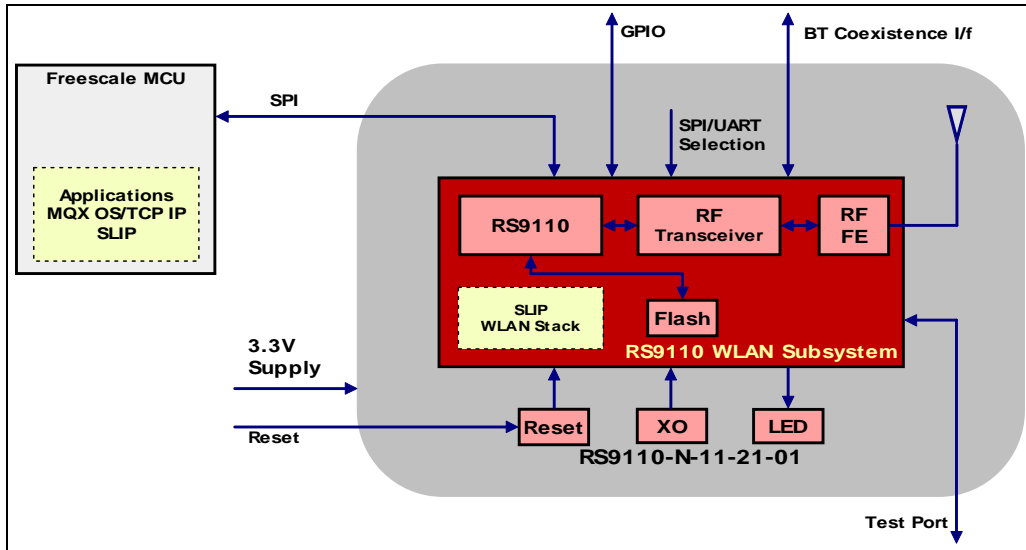

Figure 2. RS9110-N-11-21 Module: Functional Block Diagram

3.2 System Power

The RS9110-N-11-21 is powered from a source in an assembled Tower System via the 3.3V supply on the Primary Elevator Connector.

3.3 Access Header

The SPI and interrupt signals are routed to both the Primary Elevator connector and a 2x5 pin header. This Access Header can be used to access the RS9110-N-11-21 module signals for probing or for use outside of the Tower System. The pinout is shown in Table 1.

Table 1. Access Header Connections

RS9110-N-11-21 Signal	Pin	Pin	RS9110-N-11-21 Signal
3.3V	1	2	GND
SPI_CLK	3	4	SPI_INTR
No Connect	5	6	No Connect
SPI_DATAOUT	7	8	SPI_CS
SPI_DATAIN	9	10	GND

3.4 Elevator Connections

The TWR-WIFI-RS2101 features two expansion card-edge connectors that interface to Elevator boards in a Tower system: the Primary and Secondary Elevator connectors. The Primary Elevator connector, comprised of sides A and B, is utilized by the TWR-WIFI-RS2101, while the Secondary Elevator connector only makes connections to ground (GND). Table 2 provides the pinout for the Primary

Elevator Connector. An “X” in the “Used” column indicates that there is a connection from the TWR-WIFI-RS2101 to that pin on the Elevator connector. An “X” in the “Jmp” column indicates that a jumper is available that can configure or isolate the connection from the Elevator connector.

Table 2. TWR-WIFI-RS2101 Primary Elevator Connector Pinout

TWR-WIFI-RS2101 Primary Connector									
Side B					Side A				
Pin #	Name	Usage	Used	Jmp	Pin #	Name	Usage	Used	Jmp
B1	5V				A1	5V			
B2	GND	Ground			A2	GND	Ground		
B3	3.3V	3.3V Power			A3	3.3V	3.3V Power		
B4	ELE_PS_SENSE				A4	3.3V	3.3V Power		
B5	GND	Ground			A5	GND	Ground		
B6	GND	Ground			A6	GND	Ground		
B7	SPI1_CLK / SDHC1_CLK				A7	SCL0			
B8	SPI1_CS1 / SDHC1_CS1				A8	SDA0			
B9	SPI1_CS0 / SDHC1_CS0				A9	GPIO9 / CTS1	POWER_EN		
B10	SPI1_MOSI / SDHC1_CMD				A10	GPIO8 / SDHC_D2			
B11	SPI1_MISO / SDHC1_D0				A11	GPIO7 / SD_WP_DET			
Mechanical Key									
B12	ETH_COL				A12	ETH_CRS			
B13	ETH_RXER				A13	ETH_MDC			
B14	ETH_TXCLK				A14	ETH_MDIO			
B15	ETH_TXEN				A15	ETH_RXCLK			
B16	ETH_TXER				A16	ETH_RXDV			
B17	ETH_TXD3				A17	ETH_RXD3			
B18	ETH_TXD2				A18	ETH_RXD2			
B19	ETH_TXD1				A19	ETH_RXD1			
B20	ETH_TXD0				A20	ETH_RXD0			
B21	GPIO1	GPIO_RST	X		A21	SSI_MCLK			
B22	GPIO2				A22	SSI_BCLK			
B23	GPIO3				A23	SSI_FS			
B24	CLKIN0				A24	SSI_RXD			
B25	CLKOUT1				A25	SSI_TXD			
B26	GND	Ground			A26	GND	Ground		
B27	AN7				A27	AN3			
B28	AN6				A28	AN2			
B29	AN5				A29	AN1			
B30	AN4				A30	AN0			
B31	GND	Ground			A31	GND	Ground		
B32	DAC1				A32	DAC0			
B33	TMR3				A33	TMR1			
B34	TMR2				A34	TMRO			
B35	GPIO4				A35	GPIO6			
B36	3.3V	3.3V Power			A36	3.3V	3.3V Power		

B37	PWM7				A37	PWM3			
B38	PWM6				A38	PWM2			
B39	PWM5				A39	PWM1			
B40	PWM4				A40	PWM0			
B41	CANRX				A41	RXD0	RS_UART_OUT		
B42	CANTX				A42	TXD0	RS_UART_IN		
B43	1WIRE				A43	RXD1			
B44	SPIO_MISO	SPI_DATAOUT	X		A44	TXD1			
B45	SPIO_MOSI	SPI_DATAIN	X		A45	GPIO			
B46	SPIO_CS0	SPI_CS	X		A46	GPIO			
B47	SPIO_CS1				A47	GPIO			
B48	SPIO_CLK	SPI_CLK	X		A48	GPIO			
B49	GND	Ground			A49	GND	Ground		
B50	SCL1				A50	GPIO			
B51	SDA1				A51	GPIO			
B52	GPIO5				A52	GPIO			
B53	USB_DP_PDOWN				A53	GPIO			
B54	USB_DM_PDOWN				A54	USB_DM			
B55	IRQ_H				A55	USB_DP			
B56	IRQ_G				A56	USB_ID			
B57	IRQ_F				A57	USB_VBUS			
B58	IRQ_E				A58	TMR7			
B59	IRQ_D				A59	TMR6			
B60	IRQ_C				A60	TMR5			
B61	IRQ_B				A61	TMR4			
B62	IRQ_A	SPI_INTR			A62	RSTIN_b			
B63	FB_ALE/FB_CS1_b				A63	RSTOUT_b	RSTOUT_RST (RESET_n)		
B64	FB_CS0_b				A64	CLKOUT0			
B65	GND	Ground			A65	GND	Ground		
B66	FB_AD15				A66	FB_AD14			
B67	FB_AD16				A67	FB_AD13			
B68	FB_AD17				A68	FB_AD12			
B69	FB_AD18				A69	FB_AD11			
B70	FB_AD19				A70	FB_AD10			
B71	FB_R/W_b				A71	FB_AD9			
B72	FB_OE_b				A72	FB_AD8			
B73	FB_D7				A73	FB_AD7			
B74	FB_D6				A74	FB_AD6			
B75	FB_D5				A75	FB_AD5			
B76	FB_D4				A76	FB_AD4			
B77	FB_D3				A77	FB_AD3			
B78	FB_D2				A78	FB_AD2			
B79	FB_D1				A79	FB_AD1			
B80	FB_D0				A80	FB_AD0			
B81	GND	Ground			A81	GND	Ground		
B82	3.3V	3.3V Power			A82	3.3V	3.3V Power		

4 Jumper Table

There are several jumpers provided for isolation, configuration, and feature selection. Refer to the following table for details. The default installed jumper settings are shown in **bold**.

Table 3. TWR-WIFI-RS2101 Jumper Table

Jumper	Option	Setting	Description
J3	Reset Selection	1-2	Connect Tower RSTOUT_B (A63) to RS9110-N-11-21/RESET_n
		2-3	Connect Tower GPIO1 (B21) to RS9110-N-11-21/RESET_n
J5	Connect POWER_EN	ON	Power to RS9110-N-11-21 module controlled by POWER_EN signal
		OFF	Power to RS9110-N-11-21 is switched off
J15	SPI/UART Interface Select	ON	RS9110-N-11-21/SPI Interface Selected for communication with Host MCU
		OFF	RS9110-N-11-21/UART Interface Selected for communication with Host MCU – this is not available as a standard feature of the TWR-WIFI-RS2101
J10	Connect Power Gate output	ON	Connect the output of the Power Gate to the 3.3V supply for RS9110-N-11-21 module
		OFF	Disconnect the output of the Power Gate to the 3.3V supply for RS9110-N-11-21 module



Freescale[™] and the Freescale logo are trademarks of Freescale Semiconductor, Inc. All other product or service names are the property of their respective owners.

© Freescale Semiconductor, Inc. 2009. All rights reserved.

Компания «Life Electronics» занимается поставками электронных компонентов импортного и отечественного производства от производителей и со складов крупных дистрибьюторов Европы, Америки и Азии.

С конца 2013 года компания активно расширяет линейку поставок компонентов по направлению коаксиальный кабель, кварцевые генераторы и конденсаторы (керамические, пленочные, электролитические), за счёт заключения дистрибьюторских договоров

Мы предлагаем:

- Конкурентоспособные цены и скидки постоянным клиентам.
- Специальные условия для постоянных клиентов.
- Подбор аналогов.
- Поставку компонентов в любых объемах, удовлетворяющих вашим потребностям.
- Приемлемые сроки поставки, возможна ускоренная поставка.
- Доставку товара в любую точку России и стран СНГ.
- Комплексную поставку.
- Работу по проектам и поставку образцов.
- Формирование склада под заказчика.
- Сертификаты соответствия на поставляемую продукцию (по желанию клиента).
- Тестирование поставляемой продукции.
- Поставку компонентов, требующих военную и космическую приемку.
- Входной контроль качества.
- Наличие сертификата ISO.

В составе нашей компании организован Конструкторский отдел, призванный помогать разработчикам, и инженерам.

Конструкторский отдел помогает осуществить:

- Регистрацию проекта у производителя компонентов.
- Техническую поддержку проекта.
- Защиту от снятия компонента с производства.
- Оценку стоимости проекта по компонентам.
- Изготовление тестовой платы монтаж и пусконаладочные работы.



Тел: +7 (812) 336 43 04 (многоканальный)

Email: org@lifeelectronics.ru