

High Frequency Ceramic Solutions

2.4GHz Impedance Matched Balun-Filter designed for TI CC2520 Chipset.

P/N: 2450BM15B0002

Detail Specification: 6/15/2015

Page 1 of 5

General Specifications

Part Number	2450BM15B0002
Frequency (MHz)	2400 - 2500
Unbalanced Impedance	50 Ω
Differential Balanced Impedance	Conjugate match to TI Chipset 2520
Insertion Loss	1.5 dB max. (-40°C to +85°C)
Insertion Loss	1.7 dB max. (-40°C to +125°C)
Return Loss (-40°C to 125°C)	9.5 dB min.
Phase Diff. (-40°C to 125°C)	180° \pm 15

Differential Mode Attenuation (dB) -40°C to 125°C	12 min. @ 1GHz
	18 min. @ 4800~5000MHz
	20 min. @ 7200~7500MHz
Input Power	2W max. CW
Reel Quantity	4,000
Operating Temperature	-40°C to +125°C
Storage Temperature Range	-40°C to +85°C
Recommended Storage Conditions of unused product on T&R	+5 ~ +35 °C, Humidity 45~75%RH, 18 mos. max

Part Number Explanation

P/N Suffix	Packaging Style	Bulk	Suffix = S	Eg. 2450BM15B0002S
	Termination	T & R	Suffix = E	Eg. 2450BM15B0002E
		100% Tin	Suffix = None	Eg. 2450BM15B0002(E or S)

Terminal Configuration

No.	Function
1	Unbalanced Port (2.2nH Ind)*
2	GND
3	Balanced Port
4	Balanced Port
5	GND
6	GND

Mechanical Dimensions

	In	mm
L	0.079 \pm 0.004	2.00 \pm 0.10
W	0.049 \pm 0.004	1.25 \pm 0.10
T	0.028 \pm 0.004	0.70 \pm 0.10
a	0.012 \pm 0.004	0.30 \pm 0.10
b	0.008 \pm 0.004	0.20 \pm 0.10
c	0.012 +.004/-0.008	0.30 +0.1/-0.2
g	0.014 \pm 0.004	0.35 \pm 0.10
p	0.026 \pm 0.002	0.65 \pm 0.05

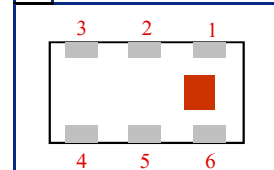
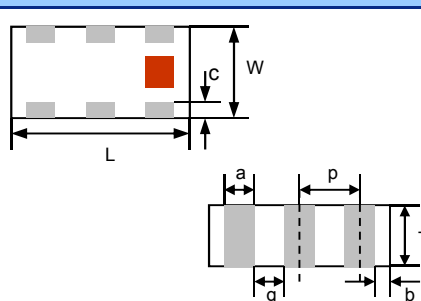

*2.2 nH Ceramic Chip inductor required on unbalanced port. See page 2 for details

Mounting Considerations

The diagram shows a top view of the device mounted on a PCB. Dimensions include 0.35 (width of the central square), 0.8 (width of the pads), 1.0 (width of the pads), and 0.30 (width of the pads). A T.I. Chipset is shown connected to the device.

Mount these devices with brown mark facing up. Units: mm

* Line width should be designed to provide 50 Ω impedance matching characteristics.

Note: No DC Blocking Capacitor required (internal)

- Solder Resist
- Land
- Through-hole (ϕ 0.3)

Johanson Technology, Inc. reserves the right to make design changes without notice.
All sales are subject to Johanson Technology, Inc. terms and conditions.



www.johansontechnology.com

4001 Calle Tecate • Camarillo, CA 93012 • TEL 805.389.1166 FAX 805.389.1821

Ver. 4.2

2015 Johanson Technology, Inc. All Rights Reserved

High Frequency Ceramic Solutions

2.4GHz Impedance Matched Balun-Filter designed for TI CC2520 Chipset.

P/N: 2450BM15B0002

Detail Specification: 6/15/2015

Page 2 of 5

Mounting Considerations

Mounting layout for reference only.
Mount device with colored mark facing up.
For detailed dimensions, please contact Johanson Technology at:
<http://www.johansontechnology.com/ask-a-question>
Or visit TI's CC2520 website:
<http://focus.ti.com/docs/prod/folders/print/cc2520.html>

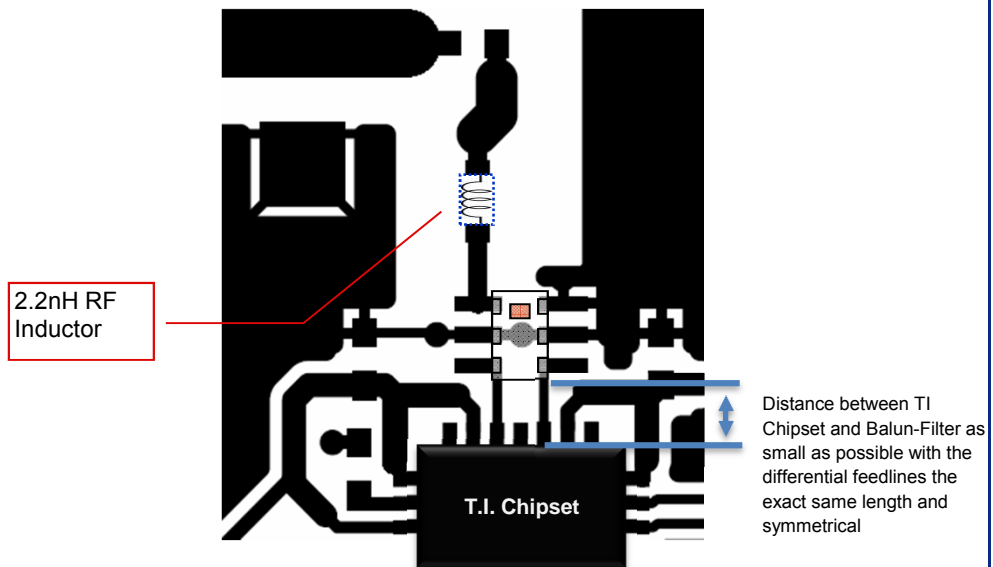

Matching Component P/N: 2.2nH Inductor: L-07C2N2SV6T
<http://www.johansontechnology.com/ceramic-inductors.html>

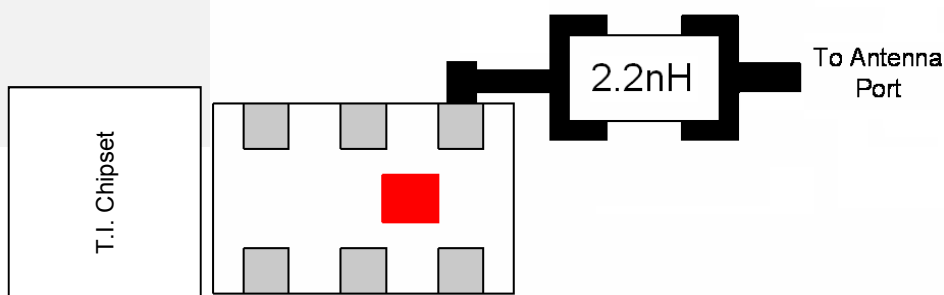

Johanson Technology, Inc. reserves the right to make design changes without notice.
All sales are subject to Johanson Technology, Inc. terms and conditions.

High Frequency Ceramic Solutions

2.4GHz Impedance Matched Balun-Filter designed for TI CC2520 Chipset.

P/N: 2450BM15B0002

Detail Specification: 6/15/2015

Page 3 of 5

Typ 25C and 125C RF Plot of Balun-Filter component only (solo)

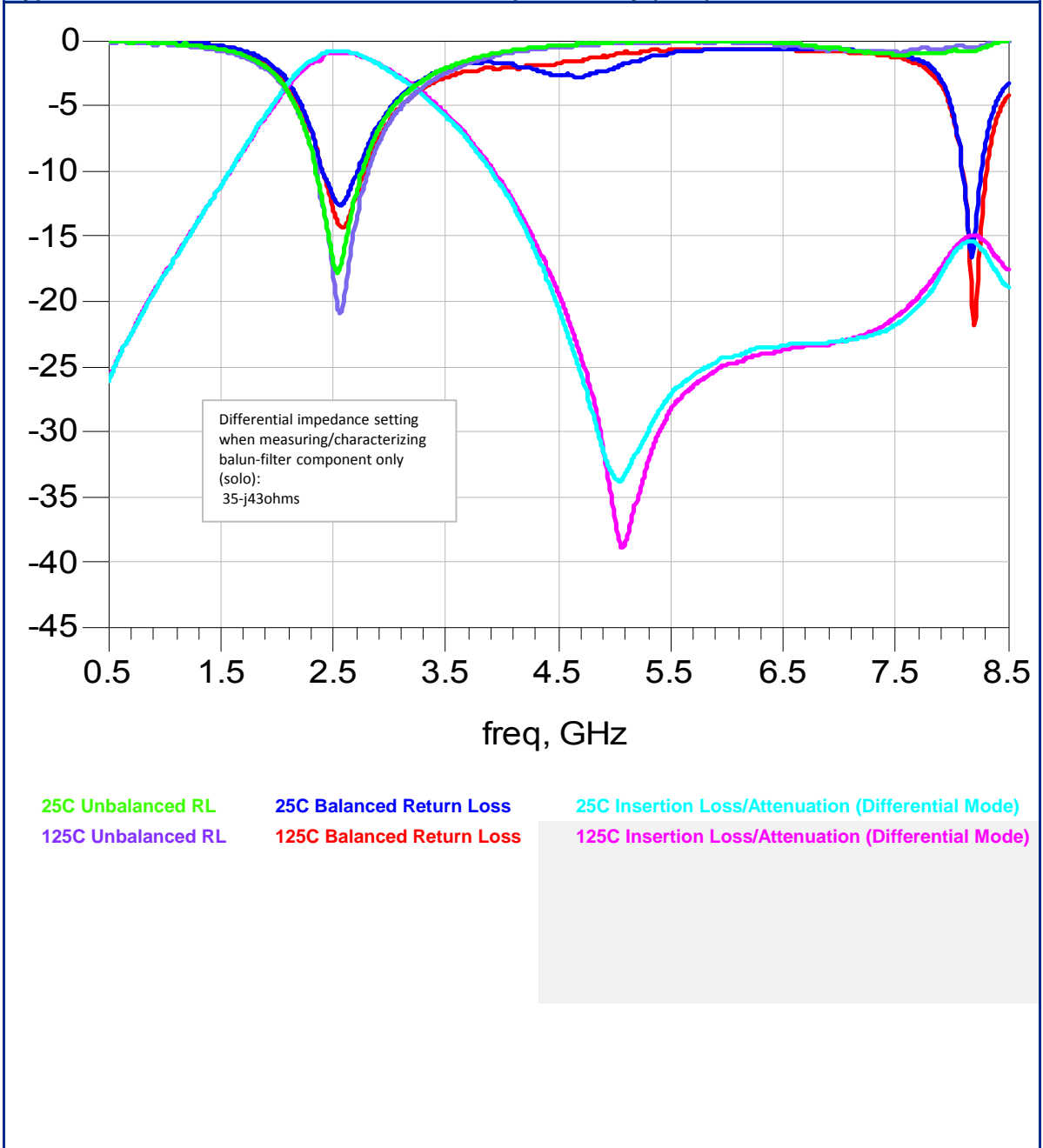

Johanson Technology, Inc. reserves the right to make design changes without notice.
All sales are subject to Johanson Technology, Inc. terms and conditions.



High Frequency Ceramic Solutions

2.4GHz Impedance Matched Balun-Filter designed for TI CC2520 Chipset.

P/N: 2450BM15B0002

Detail Specification: 6/15/2015

Page 4 of 5

Typical Electrical Performance (T=25°C) when balun-filter connected to TI CC2520 + 2.2nH inductor in series

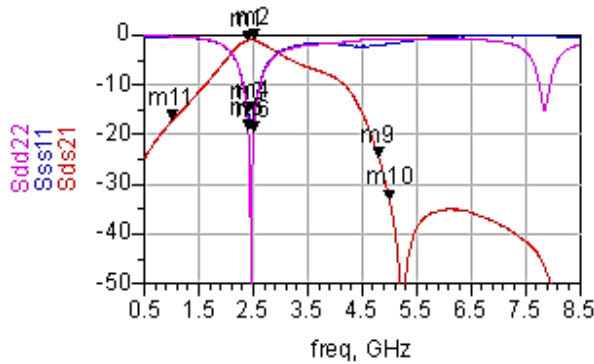

m1 freq=2.400GHz Sds21=-1.031	m3 freq=2.400GHz Sss11=-15.864
m2 freq=2.500GHz Sds21=-0.984	m4 freq=2.500GHz Sss11=-15.482
m9 freq=4.800GHz Sds21=-24.753	m5 freq=2.400GHz Sdd22=-19.050
m10 freq=5.000GHz Sds21=-33.093	m6 freq=2.500GHz Sdd22=-19.495
m11 freq=1.000GHz Sds21=-17.227	

Differential impedance setting when simulating the balun-filter component connected to TI CC2520 + 2.2nH inductor in series:
47-j34ohms

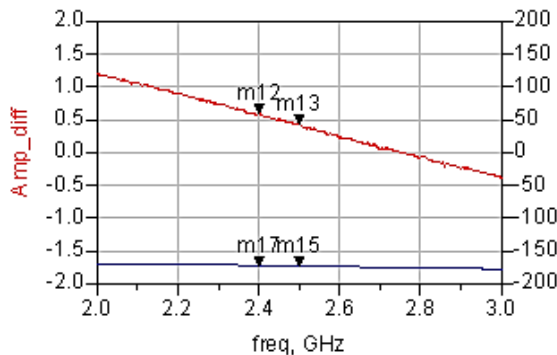

m12 freq=2.400GHz Amp_diff=0.602	m13 freq=2.500GHz Amp_diff=0.442
m17 freq=2.400GHz Phase_diff=-171.751	m15 freq=2.500GHz Phase_diff=-172.415

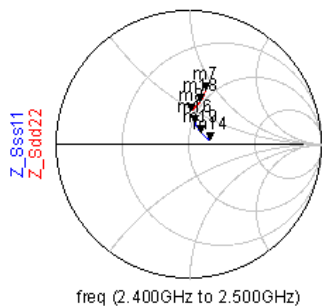

m7 freq=2.400GHz Z_Sdd22=0.427 / 72.813 impedance = 44.083 + j43.972	m14 freq=2.400GHz Z_Sss11=0.165 / 11.169 impedance = 69.105 + j4.534
m8 freq=2.500GHz Z_Sdd22=0.253 / 86.418 impedance = 45.335 + j24.449	m16 freq=2.500GHz Z_Sss11=0.168 / 74.863 impedance = 51.662 + j17.268
m18 freq=2.450GHz Z_Sdd22=0.332 / 75.072 impedance = 47.371 + j34.155	m19 freq=2.450GHz Z_Sss11=0.126 / 44.208 impedance = 58.899 + j10.499

Johanson Technology, Inc. reserves the right to make design changes without notice.
All sales are subject to Johanson Technology, Inc. terms and conditions.

"High Frequency Ceramic Solutions"

2.4GHz Impedance Matched Balun-Filter designed for TI CC2520
Chipset.

P/N: 2450BM15B0002

Detail Specification: 6/15/2015

Page 5 of 5

Application Notes, Layout Files, and more

www.johansontechnology.com/ti

RoHS Compliance

www.johansontechnology.com/technical-notes/rohs-compliance.html

Soldering Information

www.johansontechnology.com/ipcsoldering-profile

Antenna layout and tuning techniques

www.johansontechnology.com/tuning

Antenna layout review, tuning, and characterization services

www.johansontechnology.com/ipcantennaservices

MSL Info

www.johansontechnology.com/technical-notes/msl-rating.html

Recommended Storage Condition and Max Shelf Life

www.johansontechnology.com/ipcstorage-shelflife

Packaging information

www.johansontechnology.com/ipcpackaging.html

Johanson Technology, Inc. reserves the right to make design changes without notice.

All sales are subject to Johanson Technology, Inc. terms and conditions.



www.johansontechnology.com

4001 Calle Tecate • Camarillo, CA 93012 • TEL 805.389.1166 FAX 805.389.1821

Ver. 4.2

2015 Johanson Technology, Inc. All Rights Reserved

Компания «Life Electronics» занимается поставками электронных компонентов импортного и отечественного производства от производителей и со складов крупных дистрибьюторов Европы, Америки и Азии.

С конца 2013 года компания активно расширяет линейку поставок компонентов по направлению коаксиальный кабель, кварцевые генераторы и конденсаторы (керамические, пленочные, электролитические), за счёт заключения дистрибьюторских договоров

Мы предлагаем:

- Конкурентоспособные цены и скидки постоянным клиентам.
- Специальные условия для постоянных клиентов.
- Подбор аналогов.
- Поставку компонентов в любых объемах, удовлетворяющих вашим потребностям.
- Приемлемые сроки поставки, возможна ускоренная поставка.
- Доставку товара в любую точку России и стран СНГ.
- Комплексную поставку.
- Работу по проектам и поставку образцов.
- Формирование склада под заказчика.
- Сертификаты соответствия на поставляемую продукцию (по желанию клиента).
- Тестирование поставляемой продукции.
- Поставку компонентов, требующих военную и космическую приемку.
- Входной контроль качества.
- Наличие сертификата ISO.

В составе нашей компании организован Конструкторский отдел, призванный помогать разработчикам, и инженерам.

Конструкторский отдел помогает осуществить:

- Регистрацию проекта у производителя компонентов.
- Техническую поддержку проекта.
- Защиту от снятия компонента с производства.
- Оценку стоимости проекта по компонентам.
- Изготовление тестовой платы монтаж и пусконаладочные работы.



Тел: +7 (812) 336 43 04 (многоканальный)

Email: org@lifeelectronics.ru