

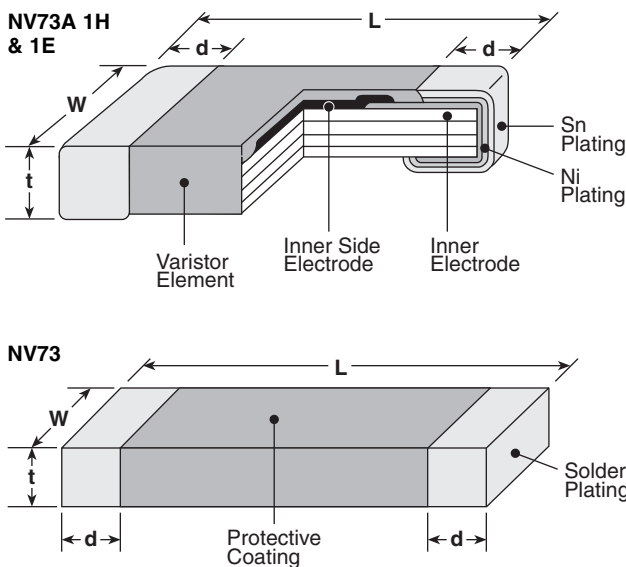

### features

- Multilayer structure
- High surge current
- Protector against static electricity, switching and incoming surges
- Marking: Black body color with no marking
- Suitable for both flow and reflow soldering
- Products with lead-free terminations meet EU RoHS requirements. Pb located in glass material, electrode and varistor element is exempt per Annex 1, exemption 5 of EU directive 2005/95/EC

### dimensions and construction



Type (Inch Size Code)	Dimensions inches (mm)			
	L	W	t	d
<b>1H</b> (0201)	.024±.001 (0.6±0.03)	.012±.001 (0.3±0.03)	.012±.001 (0.3±0.03)	.004 min. (0.1 min.)
<b>1E</b> (0402)	.023±.004 (1.0±0.1)	.02±.004 (0.5±0.1)	.023 max. (0.6 max.)	.01±.006 (0.25±0.15)
<b>1J</b> (0603)	.063±.006 (1.6±0.15)	.031±.006 (0.8±0.15)	.031±.006 (0.8±0.15)	.016 <sup>+0.006</sup> <sub>-0.008</sub> (0.4 <sup>+0.15</sup> <sub>-0.2</sub> )
<b>2A</b> (0805)	.079±.008 (2.0±0.2)	.049±.008 (1.25±0.2)	.051 max. (1.3 max.)	.02±.010 (0.5±0.25)
<b>2B</b> (1206)	.126±.008 (3.2±0.2)	.063±.008 (1.6±0.2)	.065 max. (1.65 max.)	.02 <sup>+0.014</sup> <sub>-0.010</sub> (0.5 <sup>+0.35</sup> <sub>-0.25</sub> )
<b>2E</b> (1210)	.126±.008 (3.2±0.2)	.098±.008 (2.5±0.2)	.059 max. (1.5 max.)	.020±.008 (0.5±0.2)
<b>2J</b> (1812)	.177±.008 (4.5±0.2)	.126±.008 (3.2±0.2)	.079 max. (2.0 max.)	.020 <sup>+0.001</sup> <sub>-0.004</sub> (0.5 <sup>+0.3</sup> <sub>-0.1</sub> )
<b>2L</b> (2220)	.224±.008 (5.7±0.2)	.197±.008 (5.0±0.2)	.098 max. (2.5 max.)	.020 <sup>+0.001</sup> <sub>-0.004</sub> (0.5 <sup>+0.3</sup> <sub>-0.1</sub> )

### ordering information

<b>NV73</b>	<b>A</b>	<b>L</b>	<b>1J</b>	<b>T</b>	<b>TE</b>	<b>8R2</b>
<b>Type</b>	<b>Energy Code</b>	<b>Capacitance Type</b>	<b>Size</b>	<b>Termination Material</b>	<b>Packaging</b>	<b>Varistor Voltage</b>
	A B C	L: Low Capacitance (1E only)	1H: 0201 1E: 0402 1J: 0603 2A: 0805 2B: 1206 2E: 1210 2J: 1812 2L: 2220	T: Sn	TBM: 2mm press paper (1H: 15,000 pieces/reel) TP: 2mm pitch paper (1E: 10,000 pieces/reel) TE: 7" embossed plastic (1J, 2A, 2B: 2,500 pieces/reel; 2J, 2L: 1,000 pieces/reel 2E: 2,000 pieces/reel)	8.2V 8R2 18V 18 "R" indicates decimal on value <10Ω

For further information on packaging, please refer to Appendix A.

circuit protection

### applications and ratings

Part Designation	Reference Varistor Voltage @ 1mA nom. (Range) Vc	Clamping Voltage V <sub>P</sub>	I <sub>P</sub>	Maximum Peak Current I <sub>P</sub> (A) @ 8/20 microsecond (2 pulses)	Maximum Energy E (J)	Maximum Allowable Voltage a.c rms (V)	Maximum Allowable Voltage d.c (V)	Operating Temp. T <sub>opt</sub> (°C)	Storage Temp. T <sub>stg</sub> (°C)	
NV73A1HTTBM12	12 (10 - 15.6)	35	—	1	0.01	—	6.5	-40°C to +85°C	-40°C to +125°C	
NV73A1ETTP8	8 (6.4 - 9.6)	20		20	0.05	4.2	5.5			
NV73A1ETTP18	18 (16.2 - 19.8)	35		5	0.03	6.1	14.0			
NV73AL1ETTP12	12 (10 - 14)	30				7.6	5.5			
NV73AL1ETTP21	21 (18 - 24)	50		2	0.005	9.1	14.0			
NV73AL1ETTP28	28 (24 - 32)	65				10.6	18.0			
NV73AL1ETTP120	120 (90 - 150)	350(1C-05A)		0.5	12.0					
NV73A1JTTE8R2	8.2 (6.8 - 9.8)	21	2A	30	0.1	4.2	6.0			
NV73A1JTTE12	12 (10 - 14.4)	29				6.1	8.6			
NV73A1JTTE15	15 (12.5 - 18)	35				7.6	10.8			
NV73A1JTTE18	18 (16 - 20)	37				9.1	12.8			
NV73A1JTTE20	20 (18 - 22)	40				10.6	15.0			
NV73A1JTTE22	22 (19 - 24)	42				12.0	16.5			
NV73A1JTTE24	24 (21.8 - 26.5)	46				14.0	18.0			
NV73A1JTTE27	27 (25 - 32)	49	17.0	22.0						
NV73A2ATTE8R2	8.2 (6.8 - 9.8)	16	1A	10	0.01	4.2	6.0			
NV73A2ATTE12	12 (10 - 14.4)	22			0.03	6.1	8.6			
NV73A2ATTE15	15 (12.5 - 18)	27			0.04	7.6	10.8			
NV73A2ATTE18	18 (16 - 20)	29				9.1	12.8			
NV73A2ATTE20	20 (18 - 22)	33			0.05	10.6	15.0			
NV73A2ATTE22	22 (19 - 24)	39				12.0	16.5			
NV73A2ATTE24	24 (21.8 - 26.5)	42		0.06	14.0	18.0				
NV73A2ATTE27	27 (25 - 32)	50		0.07	17.0	22.0				
NV73A2ATTE33	33 (30 - 39)	60		0.12	20.0	26.0				
NV73A2ATTE39	39 (37 - 47)	72			25	0.14	25.0			31.0
NV73A2ATTE47	47 (45 - 54)	86		0.16		30.0	38.0			
NV73B2ATTE8R2	8.2 (6.8 - 9.8)	18		2A	20	0.03	4.2			6.0
NV73B2ATTE12	12 (10 - 14.4)	22				0.05	6.1			8.6
NV73B2ATTE15	15 (12.5 - 18)	30	35		0.07	7.6	10.8			
NV73B2ATTE18	18 (16 - 20)	32			0.08	9.1	12.8			
NV73B2ATTE20	20 (18 - 22)	36			0.09	10.6	15.0			
NV73B2ATTE22	22 (19 - 24)	40			0.11	12.0	16.5			
NV73B2ATTE24	24 (21.8 - 26.5)	42			0.12	14.0	18.0			
NV73B2ATTE27	27 (25 - 32)	58			0.24	17.0	22.0			
NV73B2ATTE33	33 (30 - 39)	66	50		0.25	20.0	26.0			
NV73C2ATTE8R2	8.2 (6.8 - 9.8)	16			25	0.04	4.2	6.0		
NV73C2ATTE12	12 (10 - 14.4)	22	2A	50	0.09	6.1	8.6			
NV73C2ATTE15	15 (12.5 - 18)	28			0.11	7.6	10.8			
NV73C2ATTE18	18 (16 - 20)	32			0.13	9.1	12.8			
NV73C2ATTE20	20 (18 - 22)	35			0.14	10.6	15.0			
NV73C2ATTE22	22 (19 - 24)	40			0.17	12.0	16.5			
NV73C2ATTE24	24 (21.8 - 26.5)	42			0.18	14.0	18.0			
NV73A2BTTE27	27 (25 - 32)	55			2A	40	0.13	17.0	22.0	
NV73A2BTTE33	33 (30 - 39)	60	0.15	20.0			26.0			
NV73A2BTTE39	39 (37 - 47)	72	0.18	25.0			31.0			
NV73A2BTTE47	47 (45 - 54)	85	0.22	30.0			38.0			
NV73A2BTTE56	56 (52 - 62)	100	0.26	35.0			45.0			

circuit protection

applications and ratings (continued)

Part Designation	Reference Varistor Voltage @ 1mA nom. (Range) V <sub>c</sub>	Clamping Voltage V <sub>P</sub>	I <sub>P</sub>	Maximum Peak Current I <sub>P</sub> (A) @ 8/20 microsecond (2 pulses)	Maximum Energy E (J)	Maximum Allowable Voltage a.c rms (V)	Maximum Allowable Voltage d.c (V)	Operating Temp. T <sub>opt</sub> (°C)	Storage Temp. T <sub>stg</sub> (°C)		
NV73B2BTTE8R2	8.2 (6.8 - 9.8)	16	2A	30	0.03	4.2	6.0	-40°C to +85°C	-40°C to +125°C		
NV73B2BTTE12	12 (10 - 14.4)	22			0.07	6.1	8.6				
NV73B2BTTE15	15 (12.5 - 18)	28			0.09	7.6	10.8				
NV73B2BTTE18	18 (16 - 20)	32			0.1	9.1	12.8				
NV73B2BTTE20	20 (18 - 22)	35			0.11	10.6	15.0				
NV73B2BTTE22	22 (19 - 24)	40			0.12	12.0	16.5				
NV73B2BTTE24	24 (21.8 - 26.5)	42			0.14	14.0	18.0				
NV73B2BTTE27	27 (25 - 32)	52			0.16	17.0	22.0				
NV73C2BTTE8R2	8.2 (6.8 - 9.8)	15	2A	40	0.06	4.2	6.0	-40°C to +85°C	-40°C to +125°C		
NV73C2BTTE12	12 (10 - 14.4)	21			0.1	6.1	8.6				
NV73C2BTTE15	15 (12.5 - 18)	27			0.13	7.6	10.8				
NV73C2BTTE18	18 (16 - 20)	29			0.15	9.1	12.8				
NV73C2BTTE20	20 (18 - 22)	31			0.17	10.6	15.0				
NV73C2BTTE22	22 (19 - 24)	35			0.19	12.0	16.5				
NV73C2BTTE24	24 (21.8 - 26.5)	38			0.2	14.0	18.0				
NV73C2BTTE27	27 (25 - 32)	48			0.24	17.0	22.0				
NV73A2ETTE15	15 (12.8 - 17.3)	30	—	400	1.0	8.0	11.0	-50°C to +125°C	-50°C to +150°C		
NV73A2ETTE18	18 (15.3 - 20.7)	34			1.2	11.0	14.0				
NV73A2ETTE22	22 (19.8 - 24.2)	39			1.4	12.0	16.5				
NV73A2ETTE24	24 (21.6 - 26.4)	39			1.4	14.0	18.0				
NV73A2ETTE27	27 (24.3 - 29.7)	44			1.7	17.0	22.0				
NV73A2ETTE33	33 (29.7 - 36.3)	54			1.9	20.0	26.0				
NV73A2ETTE39	39 (35.1 - 42.9)	65			1.7	25.0	30.0				
NV73A2ETTE47	47 (42.3 - 51.7)	77			2.0	30.0	38.0				
NV73A2ETTE56	56 (50.4 - 61.6)	90		2.0	35.0	45.0					
NV73A2ETTE82	82 (73.8 - 90.2)	135		250	1.2	50.0	65.0				
NV73A2ETTE100	100 (90.0 - 110.0)	165		200	1.4	60.0	85.0				
NV73A2ETTE110	110 (99.0 - 121.0)	180			1.4	70.0	90.0				
NV73A2JTTE12	12 (10.2 - 13.8)	27		500	0.9	6.0	9.0			-50°C to +125°C	-50°C to +150°C
NV73A2JTTE15	15 (12.8 - 17.3)	32			1.2	8.0	11.0				
NV73A2JTTE18	18 (16.2 - 19.8)	35			1.4	11.0	14.0				
NV73A2JTTE22	22 (19.8 - 24.2)	41			1.6	12.0	16.5				
NV73A2JTTE24	24 (21.6 - 26.4)	44	1.7		14.0	18.0					
NV73A2JTTE27	27 (24.3 - 29.7)	49	2.0		17.0	22.0					
NV73A2JTTE33	33 (29.7 - 36.3)	54	2.5		20.0	26.0					
NV73A2JTTE39	39 (35.1 - 42.9)	65	2.9		25.0	30.0					
NV73A2JTTE47	47 (42.3 - 51.7)	77	3.5		30.0	38.0					
NV73A2JTTE56	56 (50.4 - 61.6)	90	4.2		35.0	45.0					
NV73A2JTTE68	68 (61.2 - 74.8)	110	4.8		40.0	56.0					
NV73A2JTTE82	82 (73.8 - 90.2)	135	4.5		50.0	65.0					
NV73A2JTTE100	100 (90 - 110)	165	400		5.8	60.0	85.0				
NV73A2JTTE110	110 (99 - 121)	180			5.8	70.0	90.0				
NV73A2JTTE150	150 (135 - 165)	248			300	5.8	95.0	127.0			
NV73B2JTTE15	15 (12.8 - 17.3)	32	800		1.8	8.0	11.0	-50°C to +125°C	-50°C to +150°C		
NV73B2JTTE18	18 (15.3 - 20.7)	35		1.9	11.0	14.0					
NV73B2JTTE22	22 (19.8 - 24.2)	41		2.3	12.0	16.5					
NV73B2JTTE24	24 (21.6 - 26.4)	44		2.3	14.0	18.0					
NV73B2JTTE27	27 (24.3 - 29.7)	49		2.7	17.0	22.0					
NV73B2JTTE33	33 (29.7 - 36.3)	54		3.0	20.0	26.0					

circuit protection

### applications and ratings (continued)

Part Designation	Reference Varistor Voltage @ 1mA nom. (Range) V <sub>c</sub>	Clamping Voltage V <sub>P</sub>	I <sub>P</sub>	Maximum Peak Current I <sub>P</sub> (A) @ 8/20 microsecond (2 pulses)	Maximum Energy E (J)	Maximum Allowable Voltage a.c rms (V)	Maximum Allowable Voltage d.c (V)	Operating Temp. T <sub>opt</sub> (°C)	Storage Temp. T <sub>stg</sub> (°C)	
NV73B2JTTE39	39 (35.1 - 42.9)	65	-	800	3.7	25.0	30.0	-50°C to +125°C	-50°C to +150°C	
NV73B2JTTE47	47 (42.3 - 51.7)	77			4.2	30.0	38.0			
NV73B2JTTE56	56 (50.4 - 61.6)	90			4.2	35.0	45.0			
NV73A2LTTE12	12 (10.2 - 13.8)	28		1000	1.9	6.0	9.0			
NV73A2LTTE15	15 (12.8 - 17.3)	33			2.3	8.0	11.0			
NV73A2LTTE18	18 (16.2 - 19.8)	36			2.7	11.0	14.0			
NV73A2LTTE22	22 (19.8 - 24.2)	41			2.9	12.0	16.5			
NV73A2LTTE24	24 (21.6 - 26.4)	45			3.1	14.0	18.0			
NV73A2LTTE27	27 (24.3 - 29.7)	48			3.8	17.0	22.0			
NV73A2LTTE33	33 (29.7 - 36.3)	57			4.3	20.0	26.0			
NV73A2LTTE39	39 (35.1 - 42.9)	65			5.5	25.0	30.0			
NV73A2LTTE47	47 (42.3 - 51.7)	77			6.3	30.0	38.0			
NV73A2LTTE56	56 (50.4 - 61.6)	90			7.7	35.0	45.0			
NV73A2LTTE68	68 (61.2 - 74.8)	110			8.8	40.0	56.0			
NV73A2LTTE100	100 (90 - 110)	165			6.8	60.0	85.0			
NV73A2LTTE110	110 (99 - 121)	180			6.8	70.0	90.0			
NV73B2LTTE15	15 (12.8 - 17.3)	33			1200	4.2	8.0			11.0
NV73B2LTTE18	18 (15.3 - 20.7)	36				5.4	11.0			14.0
NV73B2LTTE22	22 (19.8 - 24.2)	41		5.8		12.0	16.5			
NV73B2LTTE24	24 (21.6 - 26.4)	45		5.8		14.0	18.0			
NV73B2LTTE27	27 (24.3 - 29.7)	48		7.2		17.0	22.0			
NV73B2LTTE33	33 (29.7 - 36.3)	57		7.8		20.0	26.0			
NV73B2LTTE39	39 (35.1 - 42.9)	65		9.6		25.0	30.0			
NV73B2LTTE47	47 (42.3 - 51.7)	77		12.0		30.0	38.0			
NV73B2LTTE56	56 (50.4 - 61.6)	90		7.7		35.0	45.0			
NV73B2LTTE82	82 (73.8 - 90.2)	135		1000		5.6	50.0			65.0

Maximum allowable voltage - the maximum sinusoidal RMS voltage or maximum DC voltage which can be applied continuously  
 E: Maximum energy - the maximum energy within the varistor voltage change of ±10% when a single impulse of 2m sec. is applied  
 I<sub>P</sub>: Maximum peak current - the maximum peak current within the varistor voltage change of ±10% when a single standard impulse of 8/20μ sec. is applied two times with an interval of 5 min.  
 T<sub>opt</sub>: Operating temperature - Ambient temperature range when the device is operating  
 T<sub>stg</sub>: Storage temperature - Temperature range without causing the device any failure

### environmental applications

#### Performance Characteristics

Parameter	Requirement Δ V±%	Test Method
Varistor Voltage	Within specified tolerance	Voltage between terminals when 1mA is flowed
Solderability	95% coverage minimum	230°C ± 5°C, 4 seconds ± 1 second; 235°C ± 5°C, 4 seconds ± 1 second***
Resistance to Solder Heat	±10%	260°C ± 5°C, 10 seconds ± 0.5 second*; 270°C ± 5°C, 3 seconds ± 0.5 second**; 260°C ± 5°C, 4 seconds ± 1 second***
Rapid Change of Temperature	±10%	-40°C (30 minutes), +125°C (30 minutes), 30 cycles; 5 cycles***
Maximum Peak Current	±10%	A single standard impulse of 8/20μ seconds, positive/negative applied once each; A single standard impulse of 8/20μ seconds, 100 pulse, 30 second interval***
Maximum Energy	±10%	A single standard impulse of 10/1000μs, once*; A single standard impulse of 2ms, once**; A single standard impulse of 10/1000μs, 100pulse, 90 second interval***
High Temperature Life with d.c. Bias	±10%	85°C ± 5°C, 1000h, Load: Maximum allowable circuit voltage (d.c.); 125°C ± 5°C, 1000h, Load: Maximum allowable circuit voltage (d.c.)***
Low Temperature Life with d.c. Bias***	±10%	-50°C ± 5°C, 1000h, Load: Maximum allowable circuit voltage (d.c.)
High Temperature Life with a.c. Bias**	±10%	85°C ± 5°C, 1000h, Load: Maximum allowable circuit voltage (V <sub>a.c.r.m.s.</sub> )
High Temperature & High Humidity Life with d.c. Bias	±10%	40°C ± 5°C, 95% RH, 500h, Load: Maximum allowable voltage (d.c.)
Capacitance*	Typical	1kHz: Others, 1MHz: Varistor voltage 120V
High Temperature Storage Life	±10%	125°C ± 5°C, 1000h; 150°C ± 5°C, 1000h***
Low Temperature Storage Life	±10%	-40°C ± 5°C, 1000h; -50°C ± 5°C, 1000h***

\* 1H, 1E \*\* 1J, 2A, 2B \*\*\* 2E, 2J, 2L

For Voltage Current Curves Graphs see Environmental Applications. Additional environmental applications can also be found at [www.koaspeer.com](http://www.koaspeer.com)  
 Specifications given herein may be changed at any time without prior notice. Please confirm technical specifications before you order and/or use. 1/05/11

circuit protection

Компания «Life Electronics» занимается поставками электронных компонентов импортного и отечественного производства от производителей и со складов крупных дистрибьюторов Европы, Америки и Азии.

С конца 2013 года компания активно расширяет линейку поставок компонентов по направлению коаксиальный кабель, кварцевые генераторы и конденсаторы (керамические, пленочные, электролитические), за счёт заключения дистрибьюторских договоров

Мы предлагаем:

- Конкурентоспособные цены и скидки постоянным клиентам.
- Специальные условия для постоянных клиентов.
- Подбор аналогов.
- Поставку компонентов в любых объемах, удовлетворяющих вашим потребностям.
- Приемлемые сроки поставки, возможна ускоренная поставка.
- Доставку товара в любую точку России и стран СНГ.
- Комплексную поставку.
- Работу по проектам и поставку образцов.
- Формирование склада под заказчика.
- Сертификаты соответствия на поставляемую продукцию (по желанию клиента).
- Тестирование поставляемой продукции.
- Поставку компонентов, требующих военную и космическую приемку.
- Входной контроль качества.
- Наличие сертификата ISO.

В составе нашей компании организован Конструкторский отдел, призванный помогать разработчикам, и инженерам.

Конструкторский отдел помогает осуществить:

- Регистрацию проекта у производителя компонентов.
- Техническую поддержку проекта.
- Защиту от снятия компонента с производства.
- Оценку стоимости проекта по компонентам.
- Изготовление тестовой платы монтаж и пусконаладочные работы.



Тел: +7 (812) 336 43 04 (многоканальный)  
Email: [org@lifeelectronics.ru](mailto:org@lifeelectronics.ru)