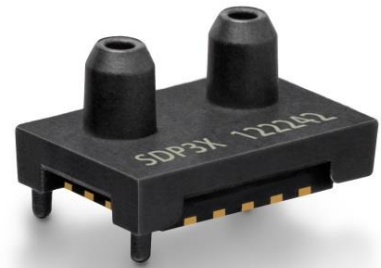


## Datasheet SDP3x-Digital

### Digital Differential Pressure Sensor

- Smallest size enables portable applications
- Reflow solderable – Pick & Place
- Excellent repeatability, no drift, no offset
- Extended feature set – smart averaging
- Calibrated and temperature compensated



### Product Summary

The SDP3x sensor family is Sensirion's series of small differential pressure sensors designed for high-volume applications where size is a key requirement. It builds on the next generation CMOSens® sensor chip that is at the heart of Sensirion's new differential pressure and flow sensing platform.

The digital SDP3x sensor features fast measurement speed, excellent accuracy and long-term stability and has no zero-point drift. Furthermore, it is reflow solderable and provides extended functionality, such as smart averaging, multiple temperature compensation modes, configurable I<sup>2</sup>C address and interrupts.

### Benefits of Sensirion's CMOSens® Technology

- High reliability and long-term stability
- Best signal-to-noise ratio
- Industry-proven technology with a track record of more than 15 years
- Designed for mass production
- High process capability

### Content

1. Sensor Performance .....	2
2. Specifications.....	3
3. Pin Assignment.....	4
4. Measurement Modes .....	5
5. Digital Interface Description .....	6
6. Package Outline.....	11
7. Soldering.....	12
8. Shipping Package .....	13
9. Ordering Information .....	13
Revision History.....	13
Important Notices .....	14
Headquarters and Subsidiaries .....	14

## 1. Sensor Performance

### 1.1 Differential Pressure Specification<sup>1</sup>

Parameter	SDP31	SDP32
Measurement range <sup>2</sup>	- 500 to 500 Pa (- 2 to 2 inH <sub>2</sub> O)	- 125 to 125 Pa (-0.5 to 0.5 inH <sub>2</sub> O)
Zero point accuracy <sup>3,4</sup>	0.1 Pa	0.08 Pa
Span accuracy <sup>3,4</sup>	3% of reading	3% of reading
Zero point repeatability <sup>4</sup>	0.03 Pa	0.025 Pa
Span repeatability <sup>4</sup>	0.5% of reading	0.5% of reading
Span shift due to temperature variation	< 0.5% of reading per 10°C	< 0.5% of reading per 10°C
Offset stability	< 0.01 Pa/year	< 0.01 Pa/year
Flow step response time ( $\tau_{63}$ )	< 3ms	
Resolution	16 bit	
Calibrated for	Air, N <sub>2</sub>	
Media compatibility	Air, N <sub>2</sub> , O <sub>2</sub> , non-condensing	
Calibrated temperature range	-40 °C to +85 °C	

### 1.2 Temperature Specification<sup>5</sup>

Parameter	Value
Measurement range	-40 °C to +85 °C
Resolution	16 bit
Accuracy	2 °C (-10 °C to +60 °C) 3 °C (-40 °C to +85 °C)
Repeatability	0.1°C

<sup>1</sup> Unless otherwise noted, all sensor specifications are valid at 25°C with VDD = 3.3 V and absolute pressure = 966 mbar.

<sup>2</sup> For other pressure ranges contact Sensirion

<sup>3</sup> Includes repeatability

<sup>4</sup> Total accuracy/repeatability is a sum of zero-point and span accuracy/repeatability.

<sup>5</sup> The measured temperature is the temperature of the bulk silicon in the sensor. This temperature value is not only depending on the gas temperature, but also on the sensor's surroundings. Using the signal to measure solely the gas temperature will need special precautions, such as isolating the sensor from external temperature influences.

## 2. Specifications

### 2.1 Electrical Specifications

Parameter	Symbol	Condition	Min.	Typ.	Max.	Units	Comments
Supply Voltage	V <sub>DD</sub>		2.7	3.3	5.5	V	
Power-up/down level	V <sub>POR</sub>		2.3	2.5	2.7	V	
Supply current	I <sub>DD</sub>	Measuring		3.8	5.5	mA	
		Idle state			1.1	mA	
		Sleep mode			1	µA	
IRQn driving strength					4	mA	

### 2.2 Timing Specifications

Parameter	Symbol	Condition	Min.	Typ.	Max.	Units	Comments
Power-up time	t <sub>PU</sub>				25	ms	Time to sensor ready
Soft reset time	t <sub>SR</sub>				20	ms	Time between soft reset command and sensor ready
I <sup>2</sup> C SCL frequency	f <sub>I2C</sub>			400	1000	kHz	
Update rate differential pressure value		Continuous mode	1800	2000	2200	Hz	
Update rate temperature value		Continuous mode	112.5			Hz	Temperature value is updated at least every 16 pressure values
Measurement time		Triggered mode	40	45	50	ms	

### 2.3 Mechanical Specifications

Parameter	Symbol	Condition	Min.	Typ.	Max.	Units	Comments
Allowable overpressure <sup>1</sup>	P <sub>max</sub>			1		bar	
Rated burst pressure	P <sub>burst</sub>		3			bar	
Weight	W				0.2	g	

### 2.4 Materials

Parameter	
Wetted materials	Glass (silicon nitride, silicon oxide), LCP, green epoxy-based mold compound, epoxy-based resins
REACH, RoHS	REACH and RoHS compliant

### 2.5 Absolute Maximum Ratings

Parameter	Rating	Units
Supply Voltage V <sub>DD</sub>	-0.3 to 5.5	V
Max Voltage on pins SDA, SCL, IRQn	-0.3 to V <sub>DD</sub> +0.3	V
Input current on any pin	±70	mA
Operating temperature range <sup>2</sup>	-40 to +85	°C
Storage temperature range <sup>3</sup>	-40 to +85	°C
Max. humidity for long term exposure	40°C dew point	
ESD HBM (human body model)	2	kV

<sup>1</sup> Allowable overpressure during operation. Refer to the SDP selection guide for pressure dependency of the measured signal. Fast absolute pressure changes on both ports can result in dynamic effects on the sensor signal. For higher overpressures or continuous high overpressures contact Sensirion.

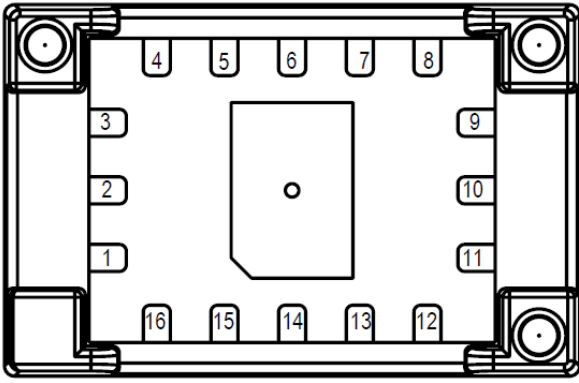
<sup>2</sup> For Air and N<sub>2</sub>. Long term exposure to high temperatures and (high concentrations of) O<sub>2</sub> can reduce the product lifetime

<sup>3</sup> For long term storage in Tape and Reel refer to the SDP3x handling instructions

### 3. Pin Assignment

The SDP3x consists of a QFN package with a plastic cap covering the top and providing the pneumatic connections to the sensor. Table 1 shows the pin assignments of the SDP3x-Digital sensor.

Pin no.	Name	Description
1	GND	Connect to ground
2	GND	Connect to ground
3	GND	Connect to ground
4	IRQn	Interrupt output. Active low. Keep floating when not used.
5	SCL	Serial Clock (I <sup>2</sup> C Interface)
6	GND	Connect to ground
7	VDD	VDD Supply
8	SDA	Bidirectional Serial Data (I <sup>2</sup> C Interface)
9	ADDR	I <sup>2</sup> C Address selection input.
10	GND	Connect to ground
11	GND	Connect to ground
12-16	-	Reserved. Do not connect



**Table 1:** SDP3x-Digital pin assignment (bottom view).

#### 3.1 Power Pins (VDD, GND)

The power supply pins must be decoupled with a 100 nF capacitor that shall be placed as close to the sensor as possible.

#### 3.2 Serial Clock and Serial Data (SCL, SDA)

The SCL and SDA are bidirectional pins of the I<sup>2</sup>C slave interface. The SCL is the Serial Clock pin and the SDA is the Serial Data pin. For more details about the I<sup>2</sup>C interface refer to section 5.

#### 3.3 ADDR Pin

The SDP3x-Digital supports different I<sup>2</sup>C addresses. With the ADDR pin an address can be selected. Connecting the ADDR pin to GND selects the default address. Other I<sup>2</sup>C addresses can be selected with a resistor connected to GND. The maximum tolerance for the resistor is  $\pm 5\%$ . Do not connect the ADDR pin to VDD.

I <sup>2</sup> C Address (Hex)	Condition
0x21	ADDR connected to GND
0x22	ADDR connected with 1.2kOhm to GND
0x23	ADDR connected with 2.7kOhm to GND

#### 3.4 IRQn Pin

The IRQn pin indicates whether new measurement results are available. The signal is active low, meaning that when the signal is high there is no new measurement data available. The IRQn will automatically clear to high when a differential pressure value is read out. The IRQn pin will also be set to low after every soft reset or Power on Reset, until a measurement command is sent.

When the IRQn signal is not used, the pin should stay unconnected and must not be connected to GND or VDD.

#### 3.5 Die Pad (Center Pad)

The die pad or center pad is visible from below and located in the center of the package. It is internally connected to GND and therefore there are no electrical constraints on connecting or not connecting the die pad to GND. For mechanical stability it is recommended to solder the center pad to the PCB.

The hole in the middle of the die pad must stay open during and after soldering.

## 4. Measurement Modes

The SDP3x-Digital is a highly versatile differential pressure sensor and is very flexible regarding the measurement speed. This flexibility not only allows for optimizing the sensor's performance to a specific application, but also for adapting the sensor to different use cases. For example, in one use case the sensor is detecting the smallest and quickest changes, whereas in another mode the sensor can measure in larger intervals while consuming only little energy.

### 4.1 Continuous Mode vs Triggered Mode

In continuous mode the sensor is measuring at the highest speed and writes the measurement values to the I<sup>2</sup>C results buffer, where the I<sup>2</sup>C master can read out the value when it requires.

For a triggered measurement the sensor is default in an idle state and wakes up when the command is sent. It then powers up the heater and does a measurement. During this time the sensor either stretches the clock or it doesn't acknowledge any I<sup>2</sup>C read header. When the measurement is finished, the sensor returns to the idle state and makes the measurement result available to be read out. For more details see chapter 5.3.3.

	Continuous mode	Triggered mode
Description	Measures continuously	Measures once after command is sent
Measurement speed and rate	Measurement result can be read out continuously and at any time, but not faster than 0.5ms.	Measurement result is available in +/- 45ms after command. Clock stretching is available.
Measurement method	Sensor configuration is optimized for speed and accuracy.	Sensor configuration is optimized for low power consumption.
Recommended use	Best used where speed and accuracy are most important.	Best used where energy consumption is more important than speed.

### 4.2 Continuous Mode and 'Average till Read'

In continuous measurement modes a new measurement result is available every 0.5ms. A new value can be read out every 0.5 ms and the IRQn will go low when a new measurement result is available.

If the 'average till read' option is chosen, the sensor averages all values ( $x_i$ ) prior to the read out. This has the benefit that the user can read out the sensor at its own desired speed, without losing information, which thus prevents aliasing. During the first 25 ms of averaging the averaged value is obtained as the arithmetic mean.

$$\bar{x} = \sum_{i=1}^N \frac{x_i}{N} \quad \text{for } t < 25 \text{ ms}$$

When the reading speed is even slower than 25 ms, the sensor will continue to average, but with another algorithm. In this algorithm exponential smoothing is used, with a smoothing factor  $\alpha = 0.05$ .

$$S_k = \alpha \cdot x_i + (1 - \alpha) \cdot S_{k-1}, \quad S_0 = \bar{x}, \quad \text{for } t > 25 \text{ ms}$$

Where  $S_0$  is the arithmetic value after the first 25 ms.

Please refer to relevant literature for more information about exponential smoothing.

### 4.3 Temperature Compensation Modes and Absolute Pressure Dependency

The SDP3x is temperature compensated both for differential pressure and for mass flow compensated differential pressure. In use cases where the SDP3x is used to measure mass flow it is advised to use mass flow temperature compensation. In this case no absolute pressure compensation is required.

For more information about temperature and absolute pressure compensation for differential pressure sensors, for example volume flow measurements in bypass, refer to the selection guide in the differential pressure download center on our website.

## 5. Digital Interface Description

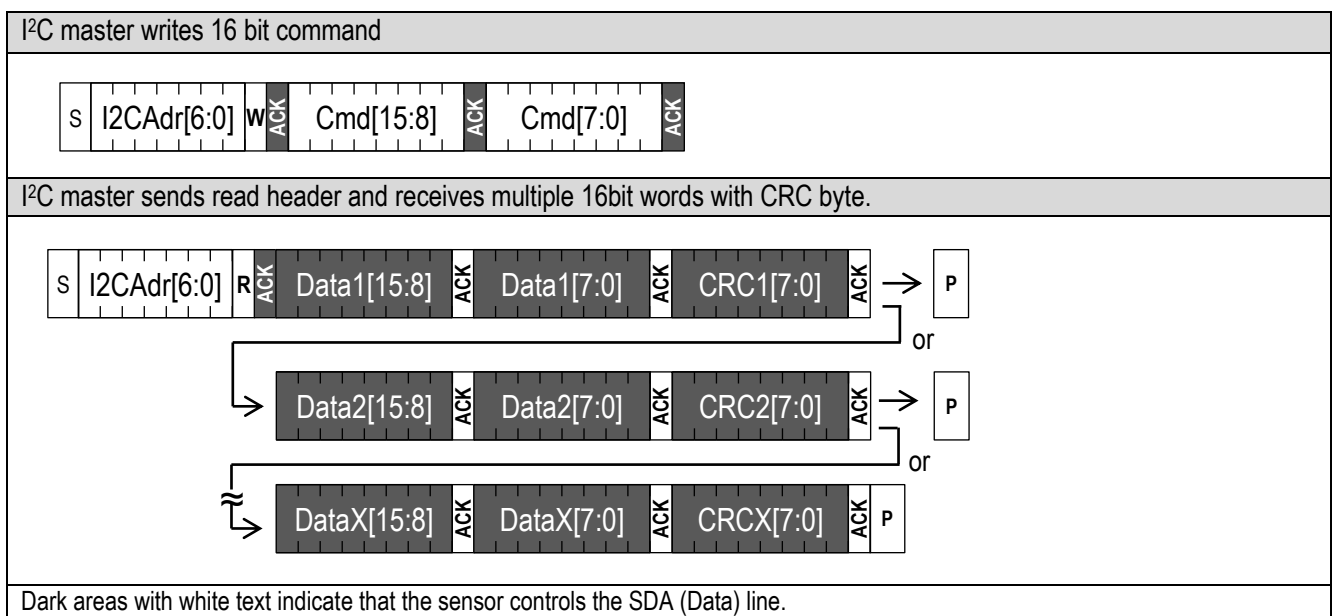
The SDP3x-digital interface is compatible with the I<sup>2</sup>C protocol. This chapter describes the command set for SDP3x-digital. For detailed information about the I<sup>2</sup>C protocol, please check the document "NXP I<sup>2</sup>C-bus specification and user manual".

### 5.1 I<sup>2</sup>C Address

The I<sup>2</sup>C address for SDP3x-digital can be selected with the ADDR pin. For more information refer to section 3.3.

### 5.2 I<sup>2</sup>C Sequences

The commands are 16-bit. Data is read from the sensor in multiples of 16-bit words, each followed by an 8-bit checksum to ensure communication reliability.



I<sup>2</sup>C sequences can be aborted with a NACK and STOP condition.

### 5.3 I<sup>2</sup>C Commands

The command set of the SDP3x-digital consists of a set of different commands:

- Continuous measurement
  - o Start Continuous measurement commands
  - o Stop Continuous measurement command
- Triggered measurement commands
- Soft reset
- Entering and exiting sleep mode
- Read product identifier and serial number

### 5.3.1 Start Continuous Measurement

The sensor measures both the differential pressure and temperature. Both measurement results can be read out through one single I<sup>2</sup>C read header.

Continuous measurements can be started up in different configurations by a set of commands.

Command code (Hex)	Temperature compensation	Averaging
0x3603	Mass flow	Average till read
0x3608	Mass flow	None - Update rate 0.5ms
0x3615	Differential pressure	Average till read
0x361E	Differential pressure	None - Update rate 0.5ms

After one of the commands has been sent, the chip continuously measures and updates the measurement results. New results can be read continuously with only an I<sup>2</sup>C read header. (Measurement) commands must not be sent until the stop measurement command has been sent.

After the start measurement command is sent:

- the first measurement result is available after 8ms.
- small accuracy deviations (few % of reading) can occur during the next 12ms.

When no measurement data is yet available the sensor will respond with a NACK to the I<sup>2</sup>C read header (I<sup>2</sup>C address + read bit).

Preceding command	Consecutive read	Description
continuous measurement	Byte1: Differential Pressure 8msb Byte2: Differential Pressure 8lsb Byte3: CRC Byte4: Temperature 8msb Byte5: Temperature 8lsb Byte6: CRC Byte7: Scale Factor differential pressure 8msb Byte8: Scale Factor differential pressure 8lsb Byte9: CRC	After a start continuous measurement command, the measurement results can be read out. The temperature and scale factor don't need to be read out (every time). The read sequence can be aborted by a NACK and a STOP condition. The scale factor is for differential pressure in Pascal.

### 5.3.2 Stop Continuous Measurement

Command	Command code (Hex)	Description
Stop continuous measurement	0x3FF9	This command stops the continuous measurement and puts the sensor in idle mode. It powers off the heater and makes the sensor receptive for another command after 500us. The Stop command is also required when switching between different continuous measurement commands.

When the sensor is in continuous measurement mode, the sensor must be stopped before it can accept another command. The only exception is the soft reset command as described in section 5.3.4.

In idle mode the sensor will consume less power, but consider the sleep mode for most effective energy saving.

### 5.3.3 Triggered Measurement

During a triggered measurement the sensor measures both differential pressure and temperature. The measurement starts directly after the command has been sent. The command needs to be repeated with every measurement.

Command code (Hex)	Temperature compensation	Clock stretching
0x3624	Mass flow	
0x3726	Mass flow	Yes
0x362F	Differential pressure	
0x372D	Differential pressure	Yes

During the 45ms that the sensor is measuring, no command can be sent to the sensor. After the 45ms the result can be read out and any command can be sent to the sensor.

Monitoring whether or not the sensor is ready with its measurement can be done with the following methods.

Method	Available	Description
Clock stretching	Only for clock stretching commands	The sensor starts the measurement after the triggered measurement command with clock stretching. When an I <sup>2</sup> C read header is sent within 45ms the sensor performs clock stretching after acknowledging the read header. When the sensor has finished the measurement, it makes the result available by releasing the SCL.
Polling	Only for non-clock stretching commands	In this mode the sensor does not acknowledge (NACK) an I <sup>2</sup> C read header as long as no measurement result is available.
IRQn	Always	The IRQn is always available to monitor whether the sensor is ready with the measurement. When the IRQn is low, the sensor indicates that a new measurement result can be read out. The IRQn is self-clearing when the result is read-out.

When new measurement data is available it can be read out by sending an I<sup>2</sup>C read header and reading out the data from the sensor. In the table below the data layout of the results can be found.

Preceding command	Consecutive read	Description
Triggered measurement	Byte1: Differential Pressure 8msb Byte2: Differential Pressure 8lsb Byte3: CRC Byte4: Temperature 8msb Byte5: Temperature 8lsb Byte6: CRC Byte7: Scale Factor differential pressure 8msb Byte8: Scale Factor differential pressure 8lsb Byte9: CRC	After a triggered measurement command, the results can be read out when the sensor is finished with the measurement. The temperature and scale factor don't need to be read out (every time). The read sequence can be aborted by a NACK and a STOP condition. The scale factor is for differential pressure in Pascal.

### 5.3.4 Soft Reset

Command	I <sup>2</sup> C address + W bit + command code (Hex)	Consecutive read	Description
General call reset	0x0006	NA	This sequence resets the sensor with a separate reset block, which is as much as possible detached from the rest of the system on chip. <u>Note that the I<sup>2</sup>C address is 0x00, which is the general call address, and that the command is 8 bit.</u> The reset is implemented according to the I <sup>2</sup> C specification.

After the reset command the sensor will take maximum 20ms to reset. During this time the sensor will not acknowledge its address nor accept commands.



### 5.3.5 Entering and Exiting Sleep Mode

In sleep mode the sensor uses the minimum amount of current. The mode can only be entered from idle mode, i.e. when the sensor is not measuring.

This mode is particularly useful for battery operated devices. To minimize the current in this mode, the complexity of the sleep mode circuit has been reduced as much as possible, which is mainly reflected by the way the sensor exits the sleep mode.

In sleep mode the sensor cannot be soft reset.

Command	Command code (Hex)	Consecutive read	Description
Enter Sleep mode	0x3677	NA	<b>Triggered mode:</b> the sleep command can be sent after the result have been read out and the sensor is in idle mode. <b>Continuous mode:</b> the sleep command can be sent after a stop continuous measurement command has been issued and the sensor is in idle mode.
Exit Sleep mode	NA	NA	The sensor exits the sleep mode and enters the idle mode when it receives the <b>valid I<sup>2</sup>C address and a write bit ('0')</b> . Note that the I <sup>2</sup> C address is <b>not</b> acknowledged. It is necessary to poll the sensor to see whether the sensor has received the address and has woken up. This should take maximum 2ms.

### 5.3.6 Read Product Identifier

During assembly and start-up of the machine it might be required to check some basic parameters in the sensor - for example to check if the correct sensor is integrated.

The product identifier and serial number can be read out after sending a sequence of two commands.

Command	Command code	Consecutive read	Description
Read product identifier	0x367C 0xE102	Byte1: Product number [31:24] Byte2: Product number [23:16] Byte3: CRC Byte4: Product number [15:8] Byte5: Product number [7:0] Byte6: CRC Byte7: Serial number [63:56] Byte8: Serial number [55:48] Byte9: CRC Byte10: Serial number [47:40] Byte11: Serial number [39:32] Byte12: CRC Byte13: Serial number [31:24] Byte14: Serial number [23:16] Byte15: CRC Byte16: Serial number [15:8] Byte17: Serial number [7:0] Byte18: CRC	Note that both commands need to be preceded with an I <sup>2</sup> C write header (I <sup>2</sup> C address + W). The second command returns: <ul style="list-style-type: none"> <li>- 32 bit unique product and revision number. The number is listed in the table below. <i>Note that the last 8 bits are the revision number and can be subject to change.</i></li> <li>- 64 bit unique serial number</li> </ul>

Product	Product number
SDP31	0x03010101
SDP32	0x03010201

## 5.4 Checksum Calculation

The checksum byte is generated by a CRC algorithm with the following properties:

Property	Value
Name	CRC-8
Protected data	read data
Width	8 bit
Polynomial	0x31 ( $x^8 + x^5 + x^4 + 1$ )
Initialization	0xFF
Reflect input	False
Reflect output	False
Final XOR	0x00
Example	$CRC(0xBEEF) = 0x92$

## 5.5 Conversion to Physical Values

Conversion of the differential pressure and temperature sensor signals to a physical value is done with the scale factor.

### 5.5.1 Scale Factors

Parameter	SDP31	SDP32
Differential Pressure (Pascal)	60 Pa <sup>-1</sup>	240 Pa <sup>-1</sup>
Differential Pressure (inches H <sub>2</sub> O)	14'945 (inH <sub>2</sub> O) <sup>-1</sup>	59'780 (inH <sub>2</sub> O) <sup>-1</sup>
Temperature	200 °C <sup>-1</sup>	200 °C <sup>-1</sup>

### 5.5.2 Differential Pressure

The digital calibrated differential pressure signal read from the sensor is a signed integer number (two's complement number). The integer value can be converted to the physical value by dividing it by the scale factor.

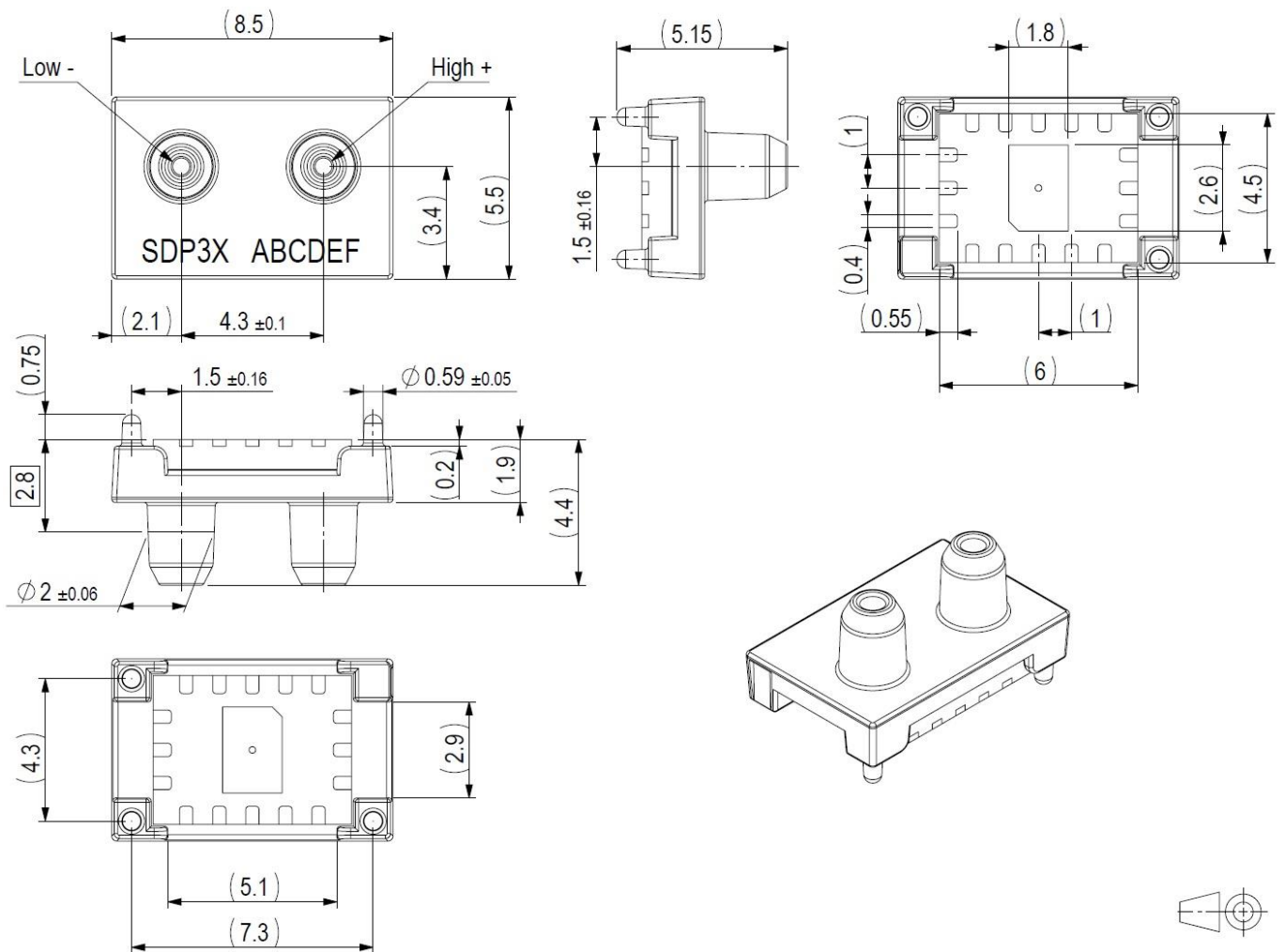
differential pressure = sensor output ÷ scale factor

### 5.5.3 Temperature

The digital calibrated temperature signal read from the sensor is a signed integer number (two's complement number). The integer value can be converted to the physical value by dividing it by the scale factor.

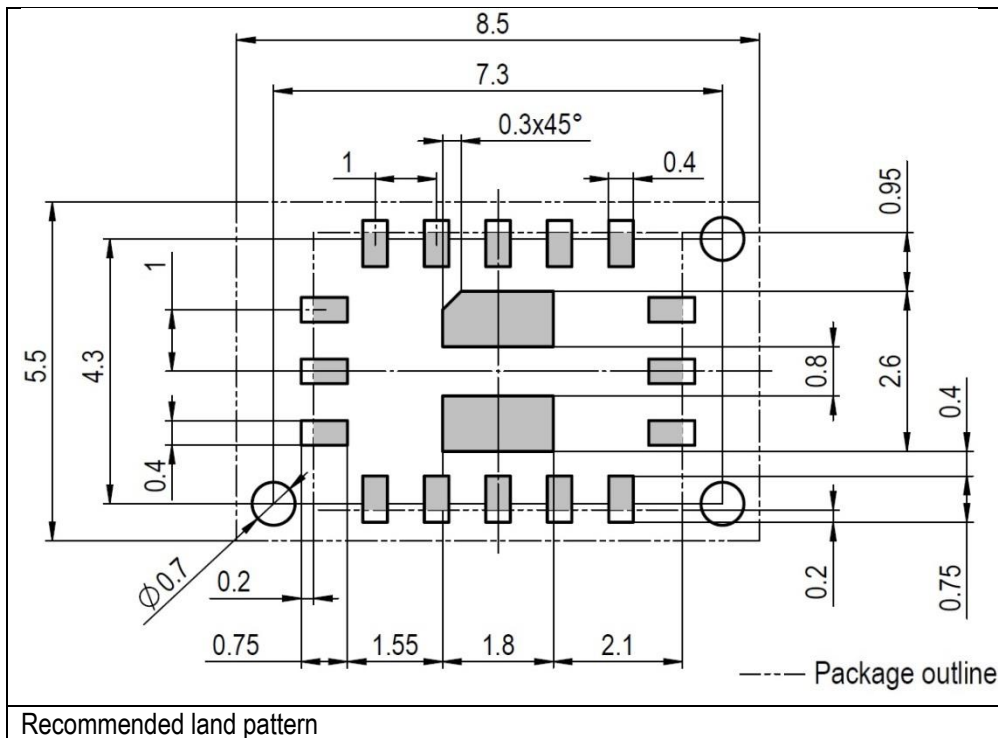
temperature in °C = sensor output ÷ scale factor

## 6. Package Outline

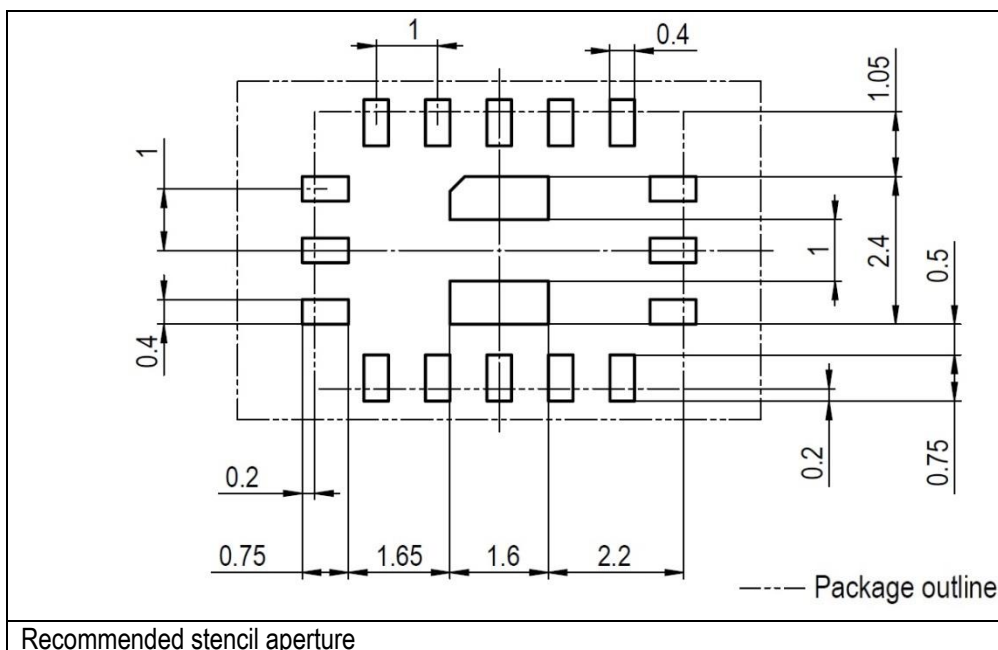


**Figure 1:** SDP3x. All dimensions in mm.

## 7. Soldering



The solder mask is understood to be the insulating layer on top of the PCB covering the copper traces. It is recommended to design the land pattern as a Non- Solder Mask Defined (NSMD) type.



The sensor must enter the reflow process only once, with a minimal temperature and exposure time. When both sides of the PCB are reflow soldered or multiple reflow runs are required, the sensor must be soldered in the last soldering run. In any case the temperature should not exceed 260°C; temperatures above 200°C should be limited in time to a maximum of 150 seconds.

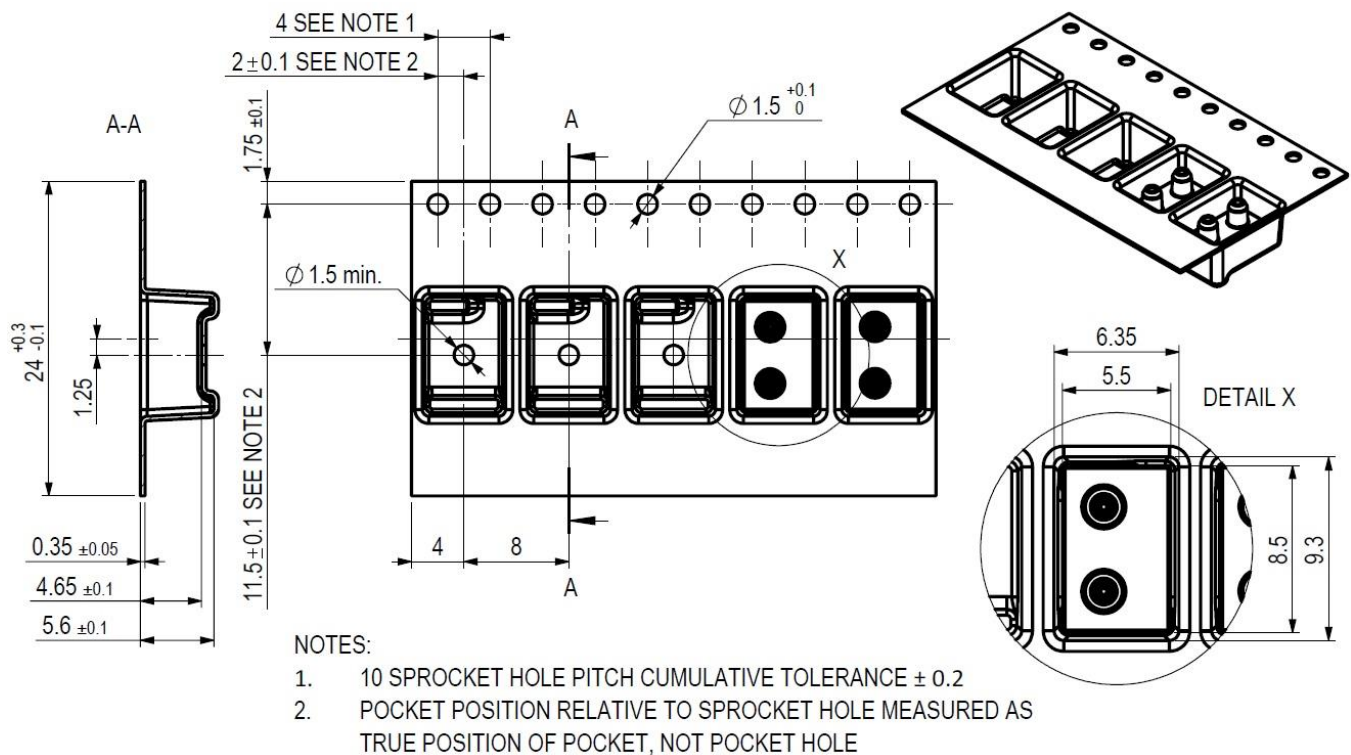
Ensure that the ports of the sensor are well protected during assembly and soldering so that no dust, solder flux or other liquids can enter the flow channel. In no case, a board wash shall be applied. It is strongly recommended to use “no-clean” solder paste.

It is important to note that the diced edge or side faces of the I/O pads may oxidize over time, therefore a solder fillet may or may not form. Hence there is no guarantee for solder joint fillet heights of any kind.

Refer to the SDP3x handling instructions on our website for more details.

## 8. Shipping Package

SDP3x are provided in tape & reel shipment packaging. Standard packaging size is 1500 or 250 units per reel. The drawing of the packaging tapes with sensor orientation is shown in *Figure 2*.



**Figure 2:** Packaging tape and sensor orientation. Header tape is to the right and trailer tape to the left on this drawing

## 9. Ordering Information

Use the part names and product numbers shown in the following table when ordering SDP3x differential pressure sensor. For the latest product information and local distributors, visit [www.sensirion.com](http://www.sensirion.com).

Part name	Description / Output	Product number	Packaging	Tape & Reel size
SDP31	I <sup>2</sup> C, 500Pa	1-101445-02	Tape & Reel (QFN Quad 2 configuration)	1500
		1-101567-02	Tape & Reel (QFN Quad 2 configuration)	250
SDP32	I <sup>2</sup> C, 125Pa	1-101498-02	Tape & Reel (QFN Quad 2 configuration)	1500
		1-101570-02	Tape & Reel (QFN Quad 2 configuration)	250

## Revision History

Date	Author	Version	Changes
01.12.2017	ANB	V1	Released. New chip revision. Voltage range extended to 2.7 to 5.5V. Update frequency increased to 0.5ms. Sleep mode added. Product number and identifier updated.

## Important Notices

### Warning, personal injury

Do not use this product as safety or emergency stop devices or in any other application where failure of the product could result in personal injury (including death). Do not use this product for applications other than its intended and authorized use. Before installing, handling, using or servicing this product, please consult the datasheet and application notes. Failure to comply with these instructions could result in death or serious injury.

If the Buyer shall purchase or use SENSIRION products for any unintended or unauthorized application, Buyer shall defend, indemnify and hold harmless SENSIRION and its officers, employees, subsidiaries, affiliates and distributors against all claims, costs, damages and expenses, and reasonable attorney fees arising out of, directly or indirectly, any claim of personal injury or death associated with such unintended or unauthorized use, even if SENSIRION shall be allegedly negligent with respect to the design or the manufacture of the product.

### ESD Precautions

The inherent design of this component causes it to be sensitive to electrostatic discharge (ESD). To prevent ESD-induced damage and/or degradation, take customary and statutory ESD precautions when handling this product.

See application note "Handling Instructions" for more information.

### Warranty

SENSIRION warrants solely to the original purchaser of this product for a period of 12 months (one year) from the date of delivery that this product shall be of the quality, material and workmanship defined in SENSIRION's published specifications of the product. Within such period, if proven to be defective, SENSIRION shall repair and/or replace this product, in SENSIRION's discretion, free of charge to the Buyer, provided that:

- notice in writing describing the defects shall be given to SENSIRION within fourteen (14) days after their appearance;

- such defects shall be found, to SENSIRION's reasonable satisfaction, to have arisen from SENSIRION's faulty design, material, or workmanship;
- the defective product shall be returned to SENSIRION's factory at the Buyer's expense; and
- the warranty period for any repaired or replaced product shall be limited to the unexpired portion of the original period.

This warranty does not apply to any equipment which has not been installed and used within the specifications recommended by SENSIRION for the intended and proper use of the equipment. EXCEPT FOR THE WARRANTIES EXPRESSLY SET FORTH HEREIN, SENSIRION MAKES NO WARRANTIES, EITHER EXPRESS OR IMPLIED, WITH RESPECT TO THE PRODUCT. ANY AND ALL WARRANTIES, INCLUDING WITHOUT LIMITATION, WARRANTIES OF MERCHANTABILITY OR FITNESS FOR A PARTICULAR PURPOSE, ARE EXPRESSLY EXCLUDED AND DECLINED.

SENSIRION is only liable for defects of this product arising under the conditions of operation provided for in the datasheet and proper use of the goods. SENSIRION explicitly disclaims all warranties, express or implied, for any period during which the goods are operated or stored not in accordance with the technical specifications.

SENSIRION does not assume any liability arising out of any application or use of any product or circuit and specifically disclaims any and all liability, including without limitation consequential or incidental damages. All operating parameters, including without limitation recommended parameters, must be validated for each customer's applications by customer's technical experts. Recommended parameters can and do vary in different applications.

SENSIRION reserves the right, without further notice, (i) to change the product specifications and/or the information in this document and (ii) to improve reliability, functions and design of this product.

Copyright © 2016-2017, SENSIRION.  
CMOSens® is a trademark of Sensirion  
All rights reserved

## Headquarters and Subsidiaries

### Sensirion AG

Laubisruetistr. 50  
CH-8712 Staefa ZH  
Switzerland

phone: +41 44 306 40 00  
fax: +41 44 306 40 30  
[info@sensirion.com](mailto:info@sensirion.com)  
[www.sensirion.com](http://www.sensirion.com)

### Sensirion Taiwan Co. Ltd

phone: +886 3 5506701  
[info@sensirion.com](mailto:info@sensirion.com)  
[www.sensirion.com](http://www.sensirion.com)

### Sensirion Inc., USA

phone: +1 312 690 5858  
[info-us@sensirion.com](mailto:info-us@sensirion.com)  
[www.sensirion.com](http://www.sensirion.com)

### Sensirion Japan Co. Ltd.

phone: +81 3 3444 4940  
[info-jp@sensirion.com](mailto:info-jp@sensirion.com)  
[www.sensirion.co.jp](http://www.sensirion.co.jp)

### Sensirion Korea Co. Ltd.

phone: +82 31 337 7700~3  
[info-kr@sensirion.com](mailto:info-kr@sensirion.com)  
[www.sensirion.co.kr](http://www.sensirion.co.kr)

### Sensirion China Co. Ltd.

phone: +86 755 8252 1501  
[info-cn@sensirion.com](mailto:info-cn@sensirion.com)  
[www.sensirion.com.cn](http://www.sensirion.com.cn)

To find your local representative, please visit [www.sensirion.com/distributors](http://www.sensirion.com/distributors)

Компания «Life Electronics» занимается поставками электронных компонентов импортного и отечественного производства от производителей и со складов крупных дистрибьюторов Европы, Америки и Азии.

С конца 2013 года компания активно расширяет линейку поставок компонентов по направлению коаксиальный кабель, кварцевые генераторы и конденсаторы (керамические, пленочные, электролитические), за счёт заключения дистрибьюторских договоров

Мы предлагаем:

- Конкурентоспособные цены и скидки постоянным клиентам.
- Специальные условия для постоянных клиентов.
- Подбор аналогов.
- Поставку компонентов в любых объемах, удовлетворяющих вашим потребностям.
- Приемлемые сроки поставки, возможна ускоренная поставка.
- Доставку товара в любую точку России и стран СНГ.
- Комплексную поставку.
- Работу по проектам и поставку образцов.
- Формирование склада под заказчика.
- Сертификаты соответствия на поставляемую продукцию (по желанию клиента).
- Тестирование поставляемой продукции.
- Поставку компонентов, требующих военную и космическую приемку.
- Входной контроль качества.
- Наличие сертификата ISO.

В составе нашей компании организован Конструкторский отдел, призванный помогать разработчикам, и инженерам.

Конструкторский отдел помогает осуществить:

- Регистрацию проекта у производителя компонентов.
- Техническую поддержку проекта.
- Защиту от снятия компонента с производства.
- Оценку стоимости проекта по компонентам.
- Изготовление тестовой платы монтаж и пусконаладочные работы.



Тел: +7 (812) 336 43 04 (многоканальный)  
Email: [org@lifeelectronics.ru](mailto:org@lifeelectronics.ru)