

Sound Processors for BOOM BOX / Mini-component Stereo



Single Power Supply Sound Processors with Built-in Pre Amplifier for Tape Recording and Play Back (With Integrated 2-/3- band Equalizer)

BD3401KS2, BD3402KS2

No.10086EAT03

●Description

The Sound Processor with built-in record/play functions for cassette players, is suited for sound quality products such as, BOOM BOX, mini- and micro-audio systems. It incorporates various functions ranging from audio source selectors to preamplifiers at the front stage, preamplifier for cassette recording/playing, and a 2-wire serial bus.

●Features

- 1) Provides Surround and Bass Boost with the Soft-switching feature to reduce the shock sound at switching (BD3401KS2)
 - 2) Provides a specialized power supply terminal in a digital circuit, in order to set and maintain the state inside the IC by the minute stand-by current.
 - 3) Built-in preamplifier for cassette recording/playing allows for minimal external components, freeing up board space.
 - 4) Arranges all I/O terminals to a single point and allows easy PCB routing.
 - 5) Volume and Tone implemented with a resistance ladder circuit; achieving high performance with low noise and low distortion
 - 6) Energy-saving design resulting in low current consumption, by utilizing the BiCMOS process.
- It has the advantage in quality over the scaling down the power heat control of the internal regulators.

●Applications

BOOM BOX, mini-audio systems, and micro-audio systems.

●Product lineup

| Parameter | BD3401KS2 | BD3402KS2 |
|--------------------------------------|--|--|
| Equalizer | 3 band(BASS, MIDDLE, TREBLE) | 2 band(BASS, TREBLE) |
| Volume | 0 to -44dB/2dB step -44 to -76dB/4dB step, -∞dB | 0 to -44dB/2dB step -44 to -76dB/4dB step, -∞dB |
| Cassette Recording/Playing Amplifier | ○ | ○ |
| Karaoke | ○ | - |
| Microphone Input | ○ | - |
| Subwoofer Output | ○ | - |
| Output for Spectrum Analyzer | ○ | - |
| Surround | ○ | - |
| Bass Boost | ○ | - |
| Package | SQFP-T64 | SQFP-T64 |

●Absolute maximum ratings (Ta=25°C)

| Items | Symbol | Ratings | Unit |
|-----------------------------|--------|--------------------|------|
| Power Supply Voltage | Vcc | 10 | V |
| | Vdd | 6 | V |
| Power Dissipation | Pd | 1200* | mW |
| Input Voltage Range | Vin | GND-0.3 to VCC+0.3 | V |
| Operating Temperature Range | Topr | -25 to +75 | °C |
| Storage Temperature Range | Tstg | -55 to +125 | °C |

* Reduced by 12 mW/°C over 25°C, when installed on the standard board (size: 70 × 70 × 1.6mm).

●Operating voltage range

| Device Name | Symbol | Range | Unit |
|-------------|--------|----------|------|
| BD3401KS2 | Vcc | 8 to 9.5 | V |
| BD3402KS2 | Vdd | 3 to 5.5 | |

● Electrical characteristics

◎ BD3401KS2

Ta=25°C, VCC=9V, VDD=5V, f=1kHz, Vi=1Vrms, RL=10kΩ, Rg=600Ω, INPUT SELECTOR=Ach, INPUT GAIN=0dB, VOLUME=0dB, TREBLE=0dB, BASS=0dB, MIDDLE=0dB, TONE ATT=0dB, MUX=STEREO, MIXING=OFF, MIXING GAIN=0dB, PLAY BACK=TAPE A, REC=OFF, LINE=OFF, MIC=OFF, BASS BOOST=OFF, SURROUND=OFF, AMS=OFF, ALC=OFF, INPUT=pin59,60, OUTPUT=pin32,33, unless otherwise noted.

| | Parameter | Symbol | Limits | | | Unit | Conditions |
|----------|---------------------------------|----------|--------|-------|------|-------|--|
| | | | Min. | Typ. | Max. | | |
| TOTAL | Circuit Current | IQ | - | 35 | 50 | mA | (No signal) |
| | Output Voltage Gain | Gv | -2 | 0 | 2 | dB | INPUT GAIN=0dB |
| | Total Harmonic Distortion ratio | THDt | - | 0.005 | 0.05 | % | BW=400 to 30kHz OUT=pin32,33,53,54 |
| | Maximum Output Voltage | Vomaxt | 2.0 | 2.5 | - | Vrms | THD=1%, BW=400 to 30kHz OUT=pin32,33,53,54 |
| | Residual Noise Voltage* | Vr | - | 1.8 | 6.0 | μVrms | Rg=0Ω, Vol=-∞dB, BW=IHF-A, |
| | Output Noise Voltage* | Vno | - | 3.0 | 9.0 | μVrms | Rg=0Ω, Vol=0dB BW=IHF-A |
| | Cross-talk between Channels* | CTC | - | -80 | -70 | dB | Rg=0Ω, BW=IHF-A VOLOUT=1Vrms |
| | Cross-talk between Selectors* | CTS | - | -80 | -70 | dB | Rg=0Ω, BW=IHF-A |
| | Input Impedance | Rin | 32 | 47 | 62 | kΩ | Pin1 to 4, 59 to 64 |
| MIXING | Total Harmonic Distortion ratio | THDmix | - | 0.01 | 0.1 | % | BW=400 to 30kHz, MIXING=ON INPUT SELECTOR=B |
| | Maximum Output Voltage | Vomaxmix | 2.0 | 2.5 | - | Vrms | THD=1%, BW=400 to 30kHz MIXING=ON INPUT SELECTOR=B |
| PLAYBACK | Output Voltage Gain | Gvp | 23 | 25 | 27 | dB | Vi=20mVrms, pin5-6, 7-8=short IN=pin9,10 OUT=pin6,7 |
| | Total Harmonic Distortion ratio | THDp | - | 0.01 | 0.1 | % | Vi=20mVrms BW=400 to 30kHz pin5-6, 7-8=short IN=pin9,10 OUT=pin6,7 |
| | Maximum Output Voltage | Vomaxp | 2.0 | 2.5 | - | Vrms | THD=1%, BW=400 to 30kHz pin5-6, 7-8=short IN=pin9,10 OUT=pin6,7 |
| | Noise Voltage in input term* | Vnin | - | 0.7 | 6.0 | μVrms | Rg=0Ω, BW=IHF-A pin5-6, 7-8=short IN=pin9,10 OUT=pin6,7 |
| | PB MUTE Amount | PBM | - | - | -70 | dB | BW=IHF-A, pin5-6, 7-8=short IN=pin9,10 PLAY BACK=MUTE |
| REC | ALC Operation Level | ALC | 0.5 | 0.7 | 0.9 | Vrms | REC=ON ALC=ON |
| | Total Harmonic Distortion ratio | THDr | - | 0.2 | 1 | % | BW=400 to 30kHz OUT=pin14,15 REC=ON ALC=ON |
| | Output Noise Voltage* | Vnor | - | 40 | 120 | μVrms | Rg=0Ω, BW=IHF-A OUT=pin14,15 REC=ON ALC=ON |

| | Parameter | Symbol | Limits | | | Unit | Conditions |
|-------------------|---|----------------------|--------------------|------|-----|------------------|---|
| | | | Min | Typ. | Max | | |
| MIC | Total Harmonic Distortion ratio | THDmic | - | 0.01 | 0.1 | % | BW=400 to 30kHz MIC=ON |
| | Maximum Output Voltage | V _{omaxmic} | 2.0 | 2.5 | - | V _{rms} | THD=1%, BW=400 to 30kHz MIC=ON |
| SPECTRUM ANALYZER | Spectrum Analyzer 1 Output Voltage Gain | G _{vs1} | -8 | -6 | -4 | dB | OUTPUT=pin55 |
| | Spectrum Analyzer 2 Output Voltage Gain | G _{vs2} | -2 | 0 | 2 | dB | OUTPUT=pin56 |
| SURROUND | Surround Gain | G _{sur} | 4 | 6 | 8 | dB | SURROUND=ON Vi=500mV _{rms} |
| TREBLE | Treble Gain | G _t | -8 to +8(2dB/step) | | | dB | Vi=500mV _{rms} |
| | Treble Gain Setting Error | TE | -2 | 0 | 2 | dB | |
| MIDDLE | Middle Gain | G _m | -8 to +8(2dB/step) | | | dB | Vi=500mV _{rms} |
| | Middle Gain Setting Error | ME | -2 | 0 | -2 | dB | |
| BASS | Bass Gain | G _b | -8 to +8(2dB/step) | | | dB | Vi=500mV _{rms} |
| | Bass Gain Setting Error | BE | -2 | 0 | -2 | dB | |
| AMS | AMS EQ Gain | G _{ams} | 33 | 35 | 37 | dB | OUTPUT=pin40 AMS=ON, Vi=20mV _{rms} |
| VOLUME | Volume Setting Error 1 | VE1 | -2 | 0 | 2 | dB | 0 to -48dB, BW=IHF-A VOLOUT=1V _{rms} |
| | Volume Setting Error 2 | VE2 | -3 | 0 | 3 | dB | -52 to -76dB, BW=IHF-A VOLOUT=1V _{rms} |
| | Maximum Attenuation* | V _{min} | - | - | -90 | dB | BW=IHF-A VOLOUT=1V _{rms} |
| SUBWOOFER | Total Harmonic Distortion ratio | THDs | - | 0.01 | 0.1 | % | Vi=500mV _{rms} BW=400 to 30kHz, OUT=pin25 No LPF |
| | Maximum Output Voltage | V _{omaxs} | 1.5 | 2.0 | 2.5 | V _{rms} | THD=3%, BW=400 to 30kHz OUT=pin25, No LPF |

ⓄBD3402KS2

Ta=25°C, VCC=9V, VDD=5V, f=1kHz, Vi=1Vrms, RL=10kΩ, Rg=600Ω, INPUT SELECTOR=Ach, INPUT GAIN=0dB, VOLUME=0dB, TREBLE=0dB, BASS=0dB, TONE ATT=0dB, MUX=STEREO, MIXING=OFF, MIXING GAIN=0dB, REC=OFF, LINE=OFF, ALC=OFF INPUT=pin59,60, OUTPUT=pin32,33, unless otherwise noted.

| | Parameter | Symbol | Limits | | | Unit | Conditions |
|----------|---------------------------------|----------|----------------------|-------|------|-------|---|
| | | | Min. | Typ. | Max. | | |
| TOTAL | Circuit Current | IQ | - | 28 | 50 | mA | (No signal) |
| | Output Voltage Gain | Gv | -2 | 0 | 2 | dB | INPUT GAIN=0dB |
| | Total Harmonic Distortion ratio | THDt | - | 0.005 | 0.05 | % | BW=400 to 30kHz OUT=pin32,33,53,54 |
| | Maximum Output Voltage | Vomaxt | 2.0 | 2.5 | - | Vrms | THD=1%, BW=400 to 30kHz OUT=pin32,33,53,54 |
| | Residual Noise Voltage* | Vr | - | 1.5 | 5.0 | μVrms | Rg=0Ω, Vol=-∞dB BW=IHF-A, |
| | Output Noise Voltage* | Vno | - | 2.5 | 8.0 | μVrms | Rg=0Ω, Vol=0dB BW=IHF-A |
| | Cross-talk between Channels* | CTC | - | -80 | -70 | dB | Rg=0Ω, BW=IHF-A VOLOUT=1Vrms |
| | Cross-talk between Selectors* | CTS | - | -80 | -70 | dB | Rg=0Ω, BW=IHF-A |
| | Input Impedance | Rin | 32 | 47 | 62 | kΩ | Pin1 to 4, 59 to 64 |
| MIXING | Total Harmonic Distortion ratio | THDmix | - | 0.01 | 0.1 | % | BW=400 to 30kHz MIXING=ON INPUT SELECTOR=B |
| | Maximum Output Voltage | Vomaxmix | 2.0 | 2.5 | - | Vrms | THD=1%, BW=400 to 30kHz MIXING=ON INPUT SELECTOR=B |
| PLAYBACK | Output Voltage Gain | Gvp | 23 | 25 | 27 | dB | Vi=20mVrms pin5-6, 7-8=short IN=pin11,12 OUT=pin6,7 |
| | Total Harmonic Distortion ratio | THDp | - | 0.01 | 0.1 | % | Vi=20mVrms BW=400 to 30kHz pin5-6, 7-8=short IN=pin11,12 OUT=pin6,7 |
| | Maximum Output Voltage | Vomaxp | 2.0 | 2.5 | - | Vrms | THD=1%, BW=400 to 30kHz pin5-6, 7-8=short IN=pin11,12 OUT=pin6,7 |
| | Noise Voltage in input term* | Vnin | - | 0.7 | 6.0 | μVrms | Rg=0Ω, BW=IHF-A pin5-6, 7-8=short IN=pin11,12 OUT=pin6,7 |
| | PB MUTE Amount | PBM | - | - | -70 | dB | BW=IHF-A, pin5-6, 7-8=short IN=pin11,12 PLAY BACK=MUTE |
| REC | ALC Operation Level | ALC | 0.5 | 0.7 | 0.9 | Vrms | REC=ON ALC=ON |
| | Total Harmonic Distortion ratio | THDr | - | 0.2 | 1 | % | BW=400 to 30kHz OUT=pin14,15 REC=ON, ALC=ON |
| | Output Noise Voltage* | Vnor | - | 40 | 120 | μVrms | Rg=0Ω, BW=IHF-A OUT=pin14,15 REC=ON, ALC=ON |
| TREBLE | Treble Gain | Gt | -8 to +8(2dB/step) | | | dB | Vi=500mVrms |
| | Treble Gain Setting Error | TE | -2 | 0 | 2 | dB | |
| BASS | Bass Gain | Gb | -12 to +12(3dB/step) | | | dB | Vi=500mVrms |
| | Bass Gain Setting Error | BE | -2 | 0 | -2 | dB | |
| VOLUME | Volume Setting Error 1 | VE1 | -2 | 0 | 2 | dB | 0 to -48dB, BW=IHF-A VOLOUT=1Vrms |
| | Volume Setting Error 2 | VE2 | -3 | 0 | 3 | dB | -52 to -76dB, BW=IHF-A VOLOUT=1Vrms |
| | Maximum Attenuation* | Vmin | - | - | -90 | dB | BW=IHF-A VOLOUT=1Vrms |

- * For measurements marked with *, VP-9690A (Average value wave detection, Effective value display) filter by Matsushita Communication Industrial is used.
- * Phase relation between Input/Output signal terminals is the same (Inputs: pin59-64, pin1-4, Outputs: pin32, 33).
- * This IC is not designed to be radiation-resistant.

●Control signal specifications

1. Signal Timing Conditions

- Data is read on the rising edge of the clock.
- Latch is read on the falling edge of the clock.
- Latch signal must terminate with the LOW state.
- To avoid malfunctions, clock and data signals must terminate with the LOW state.

1byte=8bit

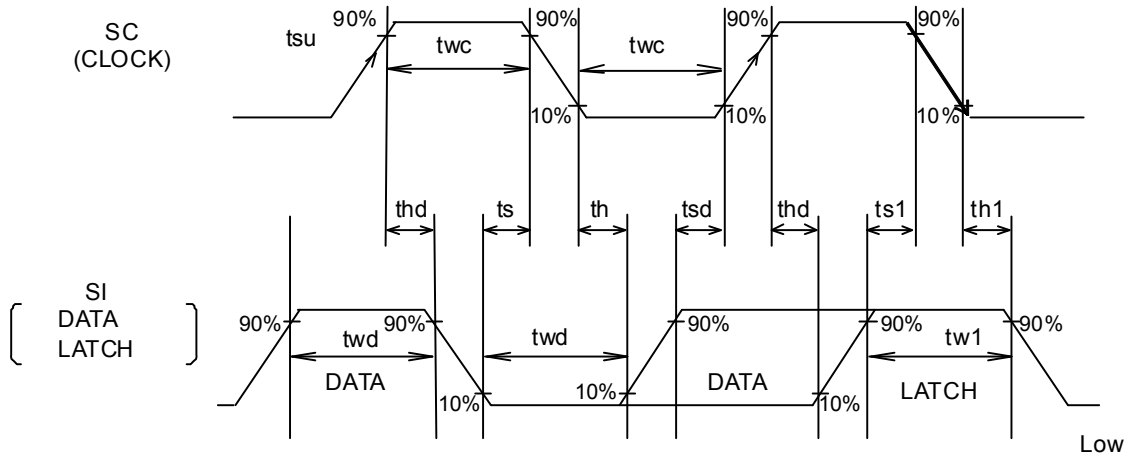

Fig.1

| Parameter | Symbol | Limits | | | Unit |
|-------------------------------|--------|--------|------|-----|------|
| | | Min | Typ. | Max | |
| Minimum Clock Width | twc | 2.0 | - | - | μS |
| Minimum Data Width | twd | 2.0 | - | - | μS |
| Minimum Latch Width | tw1 | 2.0 | - | - | μS |
| Data Set-up Time (DATA→CLK) | tsd | 1.0 | - | - | μS |
| Data Hold Time (CLK→DATA) | thd | 1.0 | - | - | μS |
| Latch Set-up Time (CLK→LATCH) | ts1 | 1.0 | - | - | μS |
| Latch Hold Time (DATA→LATCH) | th1 | 1.0 | - | - | μS |
| Latch Low Set-up Time | ts | 1.0 | - | - | μS |
| Latch Low Hold Time | th | 1.0 | - | - | μS |

2. Voltage Conditions for Control Signals

| Parameter | Symbol | Limits | | | Unit |
|-------------------|---------------|--------|------|-----|------|
| | | Min | Typ. | Max | |
| “H” Input Voltage | Vcc=8 to 9.5V | 2.2 | - | 5.5 | V |
| “L” Input Voltage | Vcc=8 to 9.5V | 0 | - | 1.0 | V |

●Control data format list

(BD3401KS2)

- Basic Configuration of Control Data Format

←Data input direction

| | | | | | | | | |
|------|------|----|----|----|----|----------------|----|-----|
| | MSB | | | | | | | LSB |
| | D7 | D6 | D5 | D4 | D3 | D2 | D1 | D0 |
| Data | Data | | | | | Select Address | | |

- Control Data Formats

←Data input direction

| | | | | | | | | |
|---------|----------------|----------|--------|-------------|-------------|----|----|----|
| | D7 | D6 | D5 | D4 | D3 | D2 | D1 | D0 |
| Data(1) | Input Selector | | | Input Gain | | 0 | 0 | 0 |
| | D7 | D6 | D5 | D4 | D3 | D2 | D1 | D0 |
| Data(2) | Volume | | | | | 0 | 0 | 1 |
| | D7 | D6 | D5 | D4 | D3 | D2 | D1 | D0 |
| Data(3) | Treble | | | | TONE ATT(1) | 0 | 1 | 0 |
| | D7 | D6 | D5 | D4 | D3 | D2 | D1 | D0 |
| Data(4) | Bass | | | | TONE ATT(2) | 0 | 1 | 1 |
| | D7 | D6 | D5 | D4 | D3 | D2 | D1 | D0 |
| Data(5) | Middle | | | | 0 | 1 | 0 | 0 |
| | D7 | D6 | D5 | D4 | D3 | | | |
| Data(6) | Subwoofer Gain | | | | 1 | 1 | 0 | 0 |
| | D7 | D6 | D5 | D4 | D3 | D2 | D1 | D0 |
| Data(7) | MUX | | MIXING | MIXING GAIN | | 1 | 0 | 1 |
| | D7 | D6 | D5 | D4 | D3 | D2 | D1 | D0 |
| Data(8) | PLAY BACK | | REC | LINE | MIC | 1 | 1 | 0 |
| | D7 | D6 | D5 | D4 | D3 | D2 | D1 | D0 |
| Data(9) | Bass Boost | Surround | AMS | ALC | Vocal Fader | 1 | 1 | 1 |

(BD3402KS2)

• Basic Configuration of Control Data Format

← Data input direction

| | | | | | | | | |
|------|------|----|----|----|----|----------------|----|-----|
| | MSB | | | | | | | LSB |
| Data | D7 | D6 | D5 | D4 | D3 | D2 | D1 | D0 |
| | Data | | | | | Select Address | | |

• Control Data Formats

← Data input direction

| | | | | | | | | |
|---------|----------------|----|--------|-------------|-------------|----|----|----|
| Data(1) | D7 | D6 | D5 | D4 | D3 | D2 | D1 | D0 |
| | Input Selector | | | Input Gain | | 0 | 0 | 0 |
| Data(2) | D7 | D6 | D5 | D4 | D3 | D2 | D1 | D0 |
| | Volume | | | | | 0 | 0 | 1 |
| Data(3) | D7 | D6 | D5 | D4 | D3 | D2 | D1 | D0 |
| | Treble | | | | TONE ATT(1) | 0 | 1 | 0 |
| Data(4) | D7 | D6 | D5 | D4 | D3 | D2 | D1 | D0 |
| | Bass | | | | TONE ATT(2) | 0 | 1 | 1 |
| Data(5) | D7 | D6 | D5 | D4 | D3 | D2 | D1 | D0 |
| | MUX | | MIXING | MIXING GAIN | | 1 | 0 | 1 |
| Data(6) | D7 | D6 | D5 | D4 | D3 | D2 | D1 | D0 |
| | * | | REC | LINE | ALC | 1 | 1 | 0 |

* * Indicates 0 or 1.

• By changing the setting of Select Address, nine different control formats are selectable.

• In every power-on sequence, all of the address data must be initialized.

Example:

← Data input direction

| | | | | | | | | | | |
|---------|-----|---------|-----|---------|-----|---------|-----|-----|---------|---|
| MSB | LSB | MSB | LSB | MSB | LSB | MSB | LSB | MSB | LSB | |
| Data(1) | L | Data(2) | L | Data(3) | L | Data(4) | L | ... | Data(9) | L |

"L" means a "latch."

• After power-on, for the second and subsequent times, only the necessary data can be selected for setting.

Example: When changing the volume,

← Data input direction

| | |
|---------|-----|
| MSB | LSB |
| Data(2) | L |

"L" means a "latch."

• TONE ATT settings

TONE ATT can be set to either one of three modes: 0dB, -4dB and -8dB using D3 in Data (3) or Data (4).

When setting TONE ATT, data should be sent as follows:

(1) TONE ATT=-4dB

(a) Sending Data (3) only

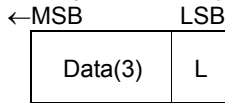

(b) Sending all the data

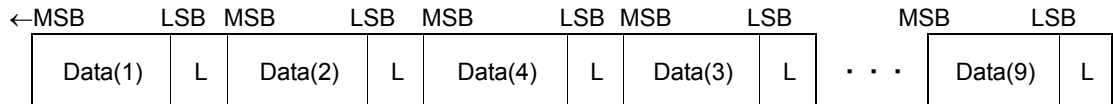

Sending Data(3) after Data(4) follows that Data(3) is given a higher priority.

(2) TONE ATT=-8dB

(a) Sending Data(4) only

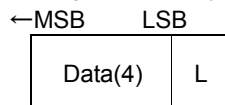

(b) Sending all the data

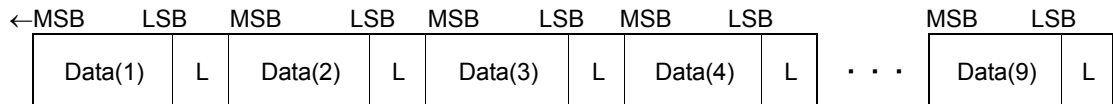

Sending Data(4) after Data(3) follows that Data(4) is given a higher priority.

● Pin description

(BD3401KS2)

| Pin No. | Pin Name | Description | Pin No. | Pin Name | Description |
|---------|----------|-----------------------------------|---------|-----------|---|
| 1 | D1 | 1ch input pin D | 33 | VOLOUT1 | 1ch output pin |
| 2 | D2 | 2ch input pin D | 34 | BBNF1 | 1ch bass boost filter setting pin |
| 3 | E1 | 1ch input pin E | 35 | BBIN1 | 1ch bass boost filter setting pin |
| 4 | E2 | 2ch input pin E | 36 | VIN1 | 1ch volume input pin |
| 5 | PBNF2 | 2ch PB filter setting pin | 37 | TONE OUT1 | 1ch tone output pin |
| 6 | PBOUT2 | 2ch PB output pin | 38 | VIN2 | 2ch volume input pin |
| 7 | PBOUT1 | 1ch PB output pin | 39 | TONE OUT2 | 2ch tone output pin |
| 8 | PBNF1 | 1ch PB filter setting pin | 40 | AMS OUT | AMS output pin |
| 9 | TAPE A1 | 1ch TAPE input pin A | 41 | BNF2 | 2ch bass filter setting pin |
| 10 | TAPE A2 | 2ch TAPE input pin A | 42 | BOUT2 | 2ch bass filter setting pin |
| 11 | TAPE B1 | 1ch TAPE input pin B | 43 | BOUT1 | 1ch bass filter setting pin |
| 12 | TAPE B2 | 2ch TAPE input pin B | 44 | BNF1 | 1ch bass filter setting pin |
| 13 | RECNF2 | 2ch REC filter setting pin | 45 | MNF1 | 1ch middle filter setting pin |
| 14 | RECOUT2 | 2ch REC output pin | 46 | MOUT1 | 1ch middle filter setting pin |
| 15 | RECOUT1 | 1ch REC output pin | 47 | MOUT2 | 2ch middle filter setting pin |
| 16 | RECNF1 | 1ch REC filter setting pin | 48 | MNF2 | 2ch middle filter setting pin |
| 17 | ALC | ALC time constant setting pin | 49 | TNF2 | 2ch treble filter setting pin |
| 18 | SC | Serial clock input pin | 50 | TNF1 | 1ch treble filter setting pin |
| 19 | SI | Serial data input pin | 51 | SUR1 | Surround setting pin |
| 20 | VDD | Digital power supply pin | 52 | SUR2 | Surround setting pin |
| 21 | GND | Ground pin | 53 | LINEOUT2 | 2ch LINE output pin |
| 22 | VCC | Analog power supply pin | 54 | LINEOUT1 | 1ch LINE output pin |
| 23 | 1/2VCC | 1/2VCC output pin | 55 | SAOUT2 | Spectrum Analyzer output pin 2 |
| 24 | FILTER | 1/2 VCC pin | 56 | SAOUT1 | Spectrum Analyzer output pin 1 |
| 25 | SW OUT | Subwoofer output pin | 57 | CAP | Time constant setting pin for absorbing switching shock sound |
| 26 | LF4 | Primary LPF setting pin | 58 | MIC | MIC input pin A |
| 27 | LF3 | Secondary LPF setting pin | 59 | A1 | 1ch input pin A |
| 28 | LF2 | Secondary LPF setting pin | 60 | A2 | 2ch input pin A |
| 29 | LF1 | Secondary LPF setting pin | 61 | B1 | 1ch input pin B |
| 30 | BBIN2 | 2ch bass boost filter setting pin | 62 | B2 | 2ch input pin B |
| 31 | BBNF2 | 2ch bass boost filter setting pin | 63 | C1 | 1ch input pin C |
| 32 | VOL OUT2 | 2ch output pin | 64 | C2 | 2ch input pin C |

●Block diagram, application circuit, pin assignment

(BD3401KS2)

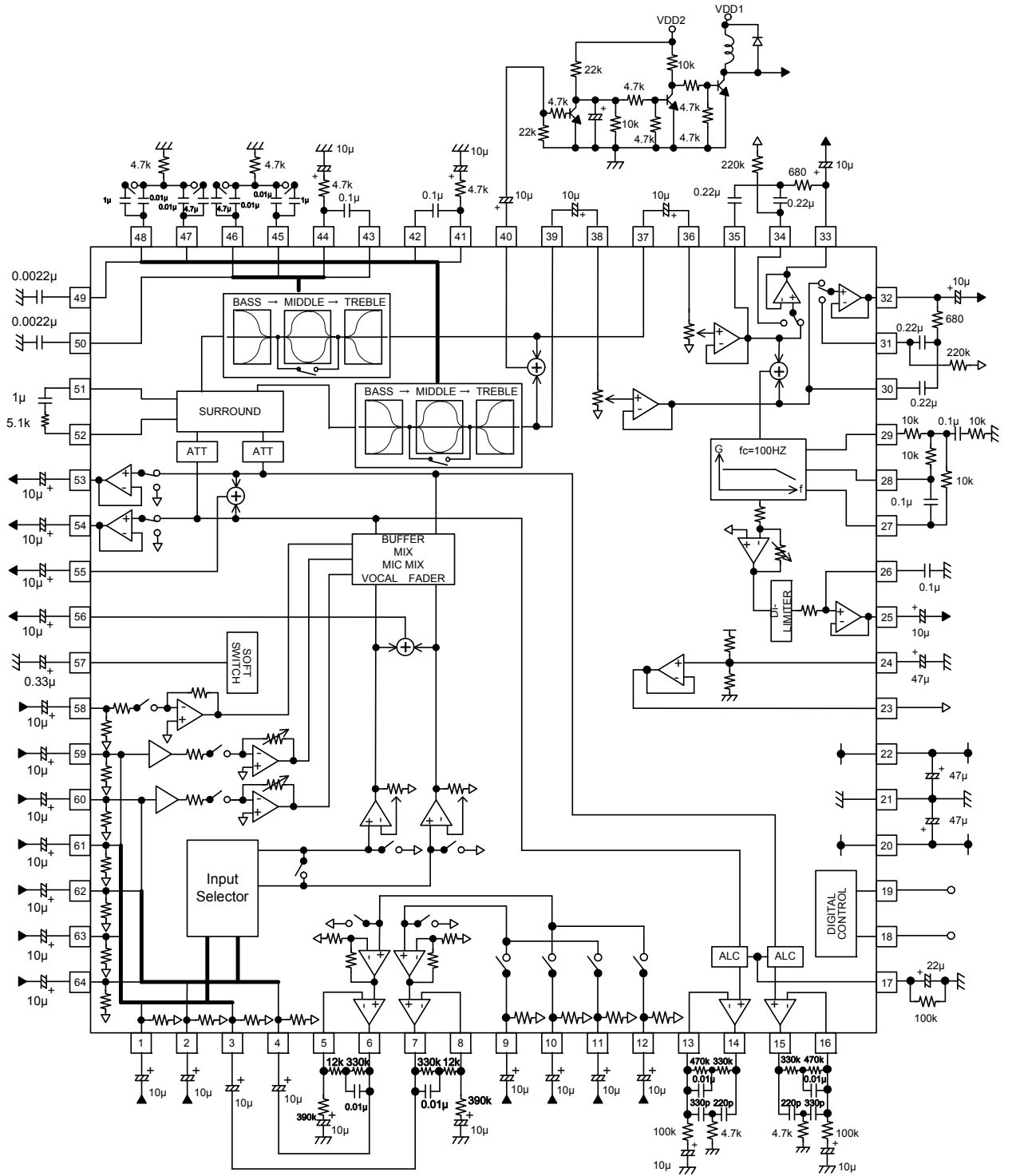

UNIT
RESISTANCE : Ω
CAPACITANCE : F

Fig.2

●Pin description
(BD3402KS2)

| Pin No. | Pin Name | Description | Pin No. | Pin Name | Description |
|---------|----------|-------------------------------|---------|-----------|-------------------------------|
| 1 | D1 | 1ch input pin D | 33 | VOL OUT1 | 1ch output pin |
| 2 | D2 | 2ch input pin D | 34 | NC | Non Connection |
| 3 | E1 | 1ch input pin E | 35 | NC | Non Connection |
| 4 | E2 | 2ch input pin E | 36 | VIN1 | 1ch volume input pin |
| 5 | PBNF2 | 2ch PB filter setting pin | 37 | TONE OUT1 | 1ch tone output pin |
| 6 | PBOUT2 | 2ch PB output pin | 38 | VIN2 | 2ch volume input pin |
| 7 | PBOUT1 | 1ch PB output pin | 39 | TONE OUT2 | 2ch tone output pin |
| 8 | PBNF1 | 1ch PB filter setting pin | 40 | NC | Non Connection |
| 9 | NC | Non Connection | 41 | BNF2 | 2ch bass filter setting pin |
| 10 | NC | Non Connection | 42 | BOUT2 | 2ch bass filter setting pin |
| 11 | TAPE 1 | 1ch TAPE input pin | 43 | BOUT1 | 1ch bass filter setting pin |
| 12 | TAPE 2 | 2ch TAPE input pin | 44 | BNF1 | 1ch bass filter setting pin |
| 13 | RECNF2 | 2ch REC filter setting pin | 45 | NC | Non Connection |
| 14 | RECOUT2 | 2ch REC output pin | 46 | NC | Non Connection |
| 15 | RECOUT1 | 1ch REC output pin | 47 | NC | Non Connection |
| 16 | RECNF1 | 1ch REC filter setting pin | 48 | NC | Non Connection |
| 17 | ALC | ALC time constant setting pin | 49 | TNF2 | 2ch treble filter setting pin |
| 18 | SC | Serial clock input pin | 50 | TNF1 | 1ch treble filter setting pin |
| 19 | SI | Serial data input pin | 51 | NC | Non Connection |
| 20 | VDD | Digital power supply pin | 52 | NC | Non Connection |
| 21 | GND | Ground pin | 53 | LINEOUT2 | 2chLINE output pin |
| 22 | VCC | Analog power supply pin | 54 | LINEOUT1 | 1chLINE output pin |
| 23 | NC | Non Connection | 55 | NC | Non Connection |
| 24 | FILTER | 1/2 VCC pin | 56 | NC | Non Connection |
| 25 | NC | Non Connection | 57 | NC | Non Connection |
| 26 | NC | Non Connection | 58 | NC | Non Connection |
| 27 | NC | Non Connection | 59 | A1 | 1ch input pin A |
| 28 | NC | Non Connection | 60 | A2 | 2ch input pin A |
| 29 | NC | Non Connection | 61 | B1 | 1ch input pin B |
| 30 | NC | Non Connection | 62 | B2 | 2ch input pin B |
| 31 | NC | Non Connection | 63 | C1 | 1ch input pin C |
| 32 | VOL OUT2 | 2ch output pin | 64 | C2 | 2ch input pin C |

● Block diagram, application circuit, pin assignment

(BD3402KS2)

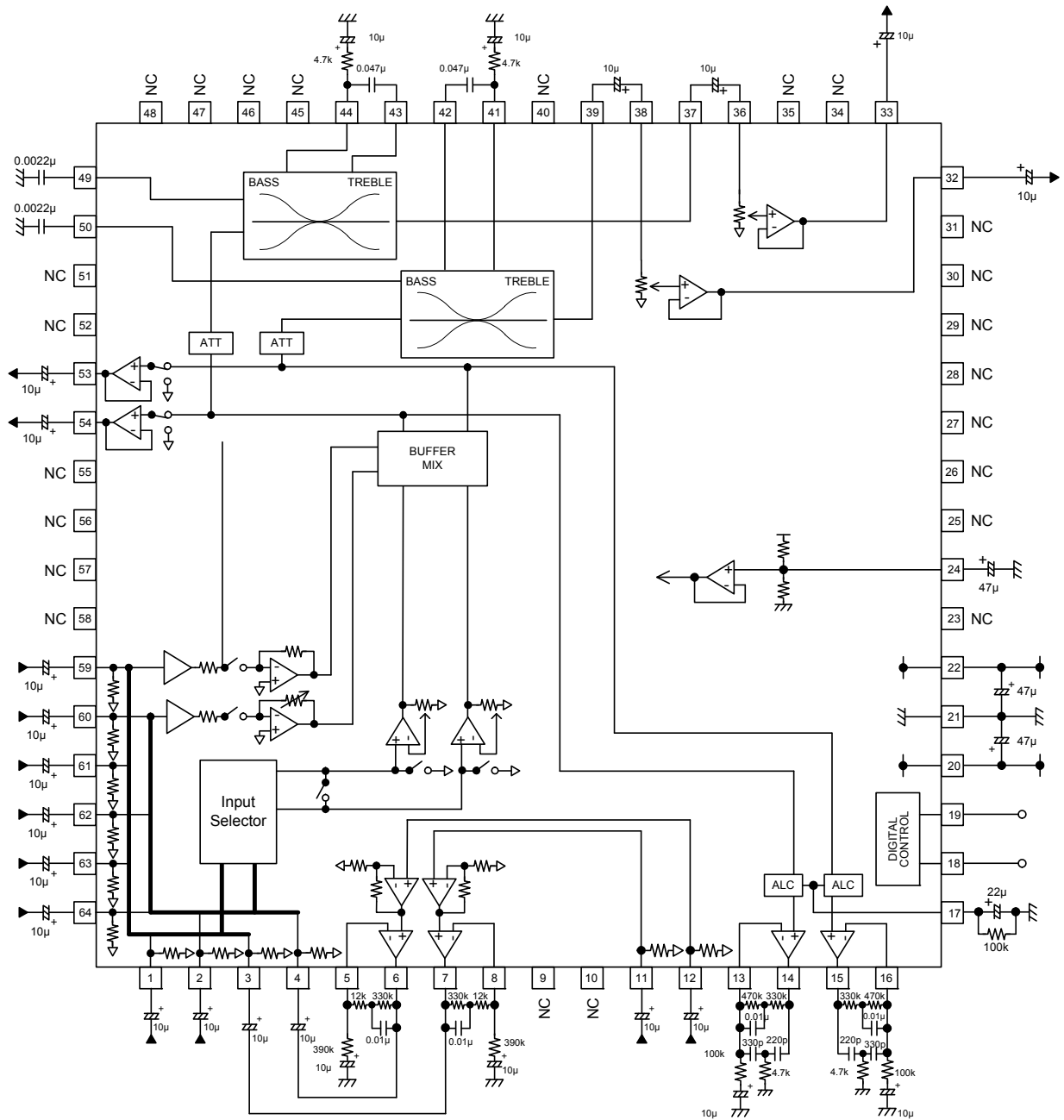

UNIT
RESISTANCE : Ω
CAPACITANCE : F

Fig.3

●Reference data

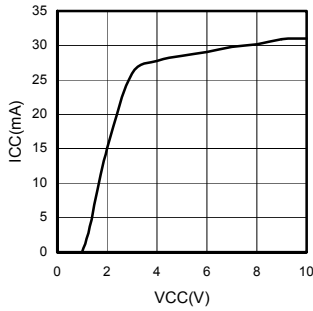

Fig.4 Circuit Current - Supply Voltage (BD3401KS2)

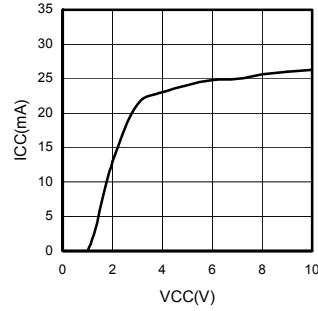

Fig.5 Circuit Current - Supply Voltage (BD3402KS2)

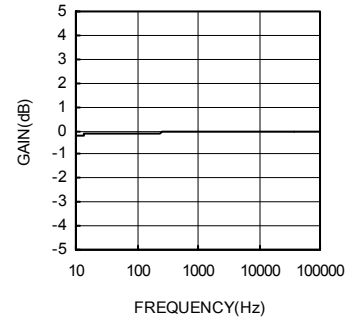

Fig.6 Voltage Gain - Frequency

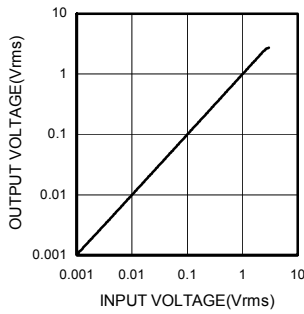

Fig.7 Output Voltage - Input Voltage

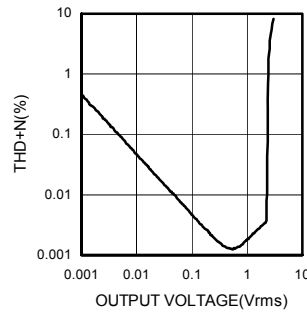

Fig.8 Total Harmonic Distortion ratio - Output Voltage

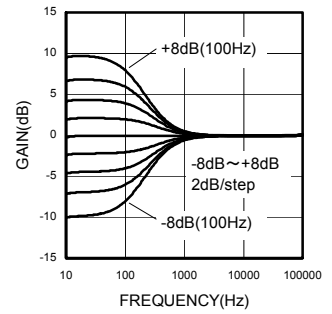

Fig.9 Bass Gain - Frequency (BD3401KS2)

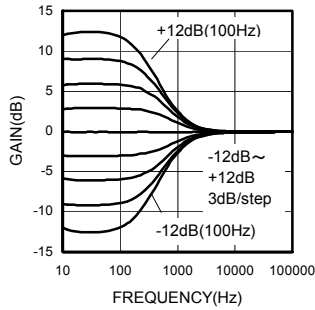

Fig.10 Bass Gain - Frequency (BD3402KS2)

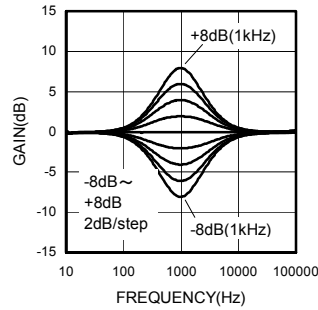

Fig.11 Middle Gain - Frequency (BD3401KS2)

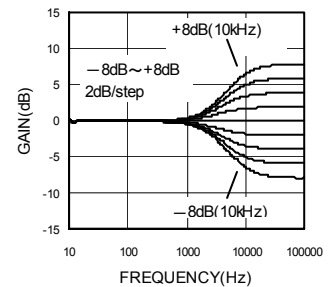

Fig.12 Treble Gain - Frequency

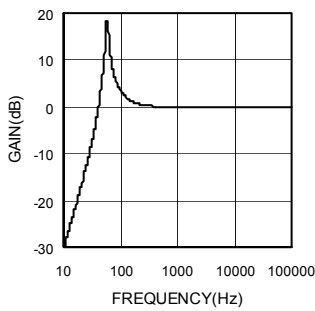

Fig.13 Bass Boost Gain - Frequency (BD3401KS2)

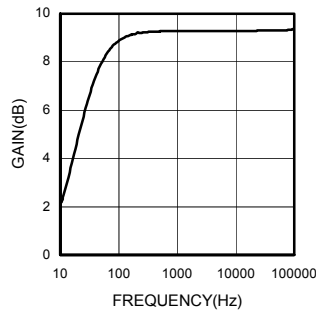

Fig.14 Surround Gain - Frequency (BD3401KS2)

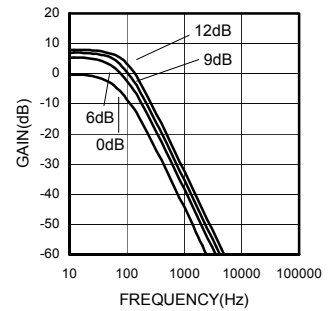

Fig.15 Subwoofer Gain - Frequency (BD3401KS2)

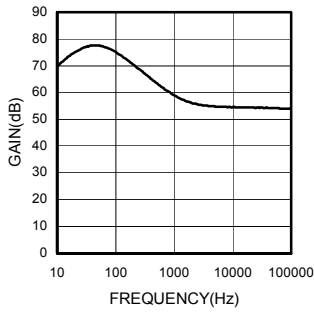

Fig. 16 Amp Gain - Frequency (PB)

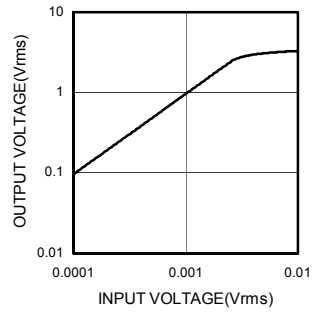

Fig. 17 Output Voltage - Input Voltage (PB)

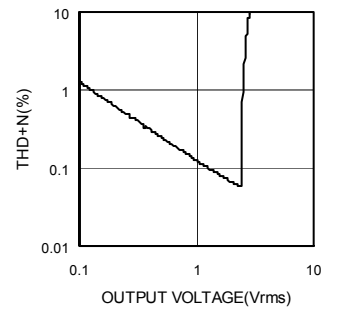

Fig. 18 Total Harmonic Distortion ratio - Output Voltage (PB)

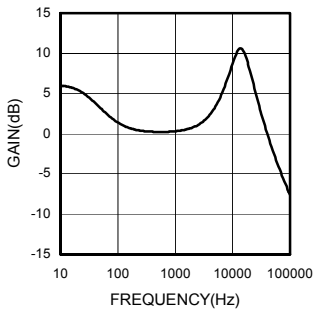

Fig. 19 Amp Gain - Frequency (REC)

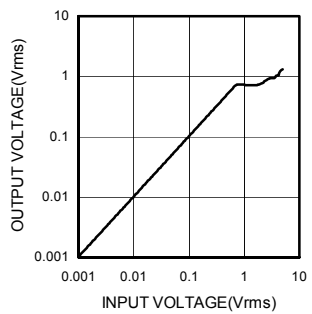

Fig. 20 Output Voltage - Input Voltage (REC)

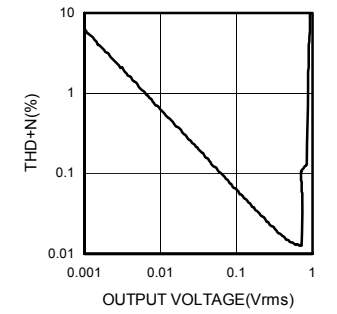

Fig. 21 Total Harmonic Distortion ratio - Output Voltage (REC)

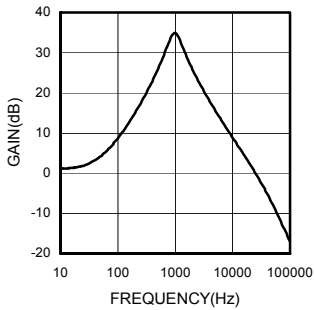

Fig. 22 AMS Gain - Frequency (BD3401KS2)

● Notes for use

- 1) Numbers and data in entries are representative design values and are not guaranteed values of the items.
- 2) Although ROHM is confident that the example application circuit reflects the best possible recommendations, be sure to verify circuit characteristics for your particular application. Modification of constants for other externally connected circuits may cause variations in both static and transient characteristics for external components as well as this Rohm IC. Allow for sufficient margins when determining circuit constants.
- 3) Absolute maximum ratings
Use of the IC in excess of absolute maximum ratings, such as the applied voltage or operating temperature range (Topr), may result in IC damage. Assumptions should not be made regarding the state of the IC (short mode or open mode) when such damage is suffered. A physical safety measure, such as a fuse, should be implemented when using the IC at times where the absolute maximum ratings may be exceeded.
- 4) GND potential
Ensure a minimum GND pin potential in all operating conditions. Make sure that no pins are at a voltage below the GND at any time, regardless of whether it is a transient signal or not.
- 5) Thermal design
Perform thermal design, in which there are adequate margins, by taking into account the permissible dissipation (Pd) in actual states of use.
- 6) Short circuit between terminals and erroneous mounting
Pay attention to the assembly direction of the ICs. Wrong mounting direction or shorts between terminals, GND, or other components on the circuits, can damage the IC.
- 7) Operation in strong electromagnetic field
Using the ICs in a strong electromagnetic field can cause operation malfunction.
- 8) Serial control
For the SC and SI terminals, the wiring and layout patterns should be routed as not to cause interference with the analog-signal-related lines.
- 9) Power ON/OFF
At power ON/OFF, a shock sound will be generated and, therefore, MUTE shall be applied.
- 10) Start-up sequence of the power supplies
VDD and VCC should be turned on simultaneously or VDD first, followed by VCC.
- 11) Function switching
(BD3401KS2)
For all functions except Master Volume, Treble, Middle, Bass, Surround, and Bass Boost, MUTE must be applied during setup.
(BD3402KS2)
For all the functions except Master Volume, Treble and Bass, MUTE must be applied during setup..
- 12) Power-ON Reset
A built-in circuit for performing initialization inside the IC at power-ON is provided. In unstable systems it is recommended that the data shall be sent to all the addresses during power-ON, until this operation cycle is completed. Mute should be applied during this cycle.

| Function | Initial State | BD3401KS2 | BD3402KS2 |
|----------------|---------------|-----------|-------------|
| Input Selector | MUTE | ○ | ○ |
| Input Gain | -5dB | ○ | ○ |
| Volume | 0dB | ○ | ○ |
| Treble | 0dB | ○ | ○ |
| Bass | 0dB | ○ | ○ |
| Middle | 0dB | ○ | - |
| TONE ATT | 0dB | ○ | ○ |
| Subwoofer | 0dB | ○ | - |
| MUX | STEREO | ○ | ○ |
| Mixing | OFF | ○ | ○ |
| Mixing Gain | 3dB | ○ | ○ |
| PLAY BACK | TAPE A | ○ | No selector |
| REC | OFF | ○ | ○ |
| LINE | OFF | ○ | ○ |
| MIC | OFF | ○ | - |
| Bass Boost | OFF | ○ | - |
| Surround | OFF | ○ | - |
| AMS | OFF | ○ | - |
| ALC | OFF | ○ | ○ |
| Vocal Fader | OFF | ○ | - |

13) Constraints of serial control

- (1) On soft-switching of the BASS BOOST, SURROUND and AMS functions, data must not be serially sent to the functions involved before the switching operation is completed.
Data (1) to (8) can be serially sent immediately after sending Data (9).

For functions that need to use soft-switch, data (Data (9)) can be serially sent on the same select address.

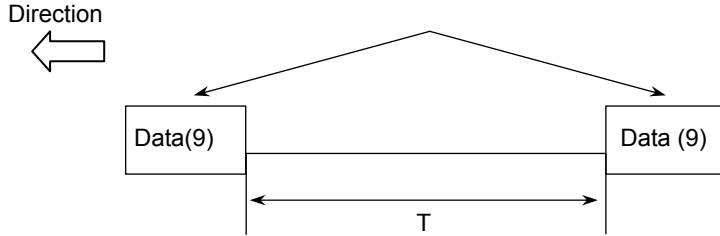

The time interval: T(sec) between Data (9) must be set to have a sufficient delay time. For example, 100ms or more when C on pin57 is 0.33μF.

Fig.23

- (2) When switching AMS ON and OFF, a shock sound will be generated. Using MUTE provided on VOLUME, control data should be sent in order to avoid outputting the shock sound from VOLOUT1,2 (pin32,33) as described in the figure below:

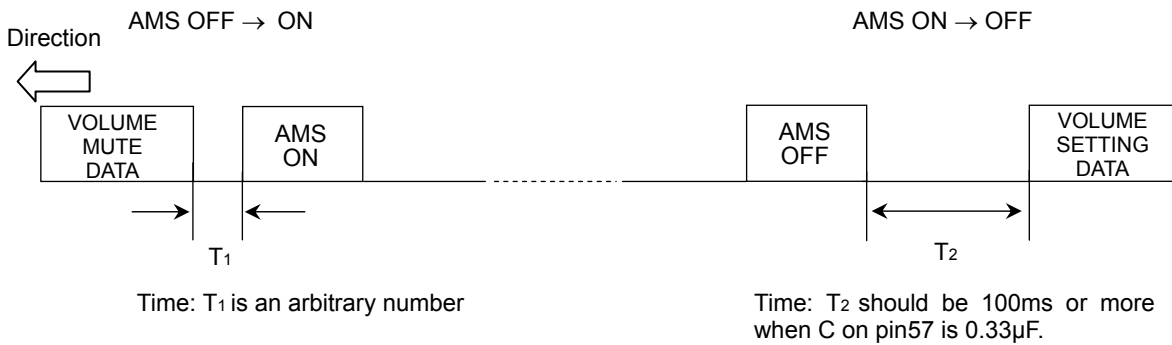

Time: T₁ is an arbitrary number

Time: T₂ should be 100ms or more when C on pin57 is 0.33μF.

Fig.24

•Thermal derating characteristic

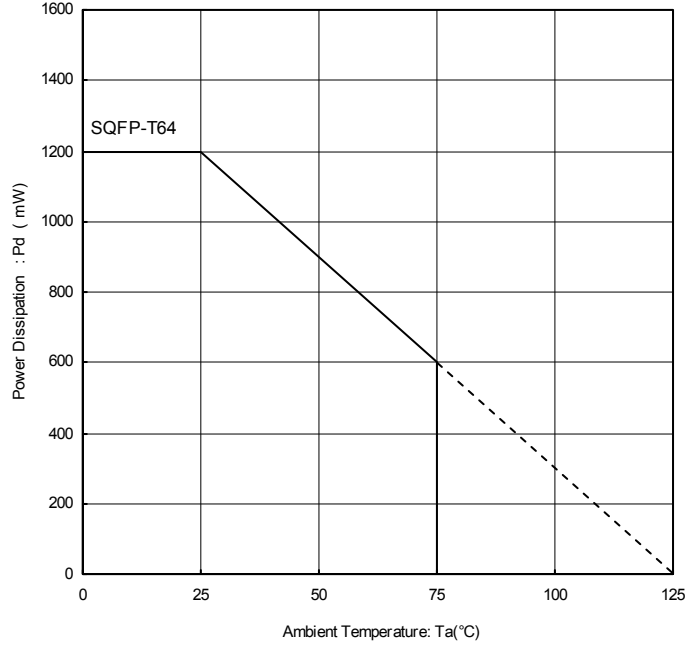

When installed on the ROHM standard board
(size: 70 × 70 × 1.6mm, Glass epoxy board)

Fig.25

● Ordering part number

| | |
|---|---|
| B | D |
|---|---|

Part No.

| | | | |
|---|---|---|---|
| 3 | 4 | 0 | 1 |
|---|---|---|---|

Part No.
3401, 3402

| | | |
|---|---|---|
| K | S | 2 |
|---|---|---|

Package
KS2: SQFP-T64

| | |
|--|--|
| | |
|--|--|

Packaging and forming specification
None: Tray

SQFP-T64

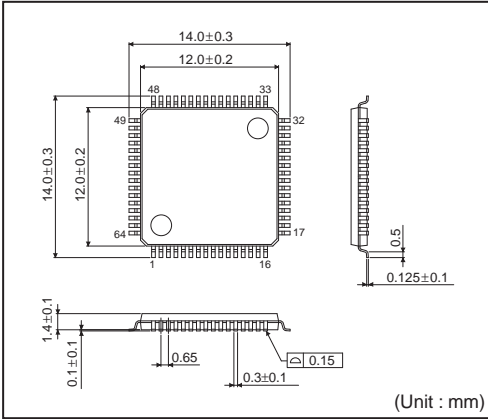

<Tape and Reel information>

| | |
|-------------------|---|
| Container | Tray (with dry pack) |
| Quantity | 1000pcs |
| Direction of feed | Direction of product is fixed in a tray |

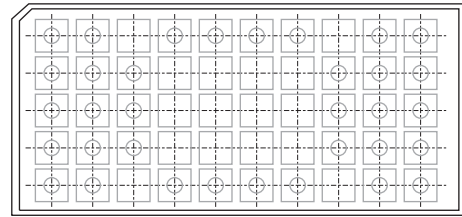
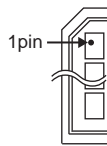

*Order quantity needs to be multiple of the minimum quantity.

Notes

No copying or reproduction of this document, in part or in whole, is permitted without the consent of ROHM Co.,Ltd.

The content specified herein is subject to change for improvement without notice.

The content specified herein is for the purpose of introducing ROHM's products (hereinafter "Products"). If you wish to use any such Product, please be sure to refer to the specifications, which can be obtained from ROHM upon request.

Examples of application circuits, circuit constants and any other information contained herein illustrate the standard usage and operations of the Products. The peripheral conditions must be taken into account when designing circuits for mass production.

Great care was taken in ensuring the accuracy of the information specified in this document. However, should you incur any damage arising from any inaccuracy or misprint of such information, ROHM shall bear no responsibility for such damage.

The technical information specified herein is intended only to show the typical functions of and examples of application circuits for the Products. ROHM does not grant you, explicitly or implicitly, any license to use or exercise intellectual property or other rights held by ROHM and other parties. ROHM shall bear no responsibility whatsoever for any dispute arising from the use of such technical information.

The Products specified in this document are intended to be used with general-use electronic equipment or devices (such as audio visual equipment, office-automation equipment, communication devices, electronic appliances and amusement devices).

The Products specified in this document are not designed to be radiation tolerant.

While ROHM always makes efforts to enhance the quality and reliability of its Products, a Product may fail or malfunction for a variety of reasons.

Please be sure to implement in your equipment using the Products safety measures to guard against the possibility of physical injury, fire or any other damage caused in the event of the failure of any Product, such as derating, redundancy, fire control and fail-safe designs. ROHM shall bear no responsibility whatsoever for your use of any Product outside of the prescribed scope or not in accordance with the instruction manual.

The Products are not designed or manufactured to be used with any equipment, device or system which requires an extremely high level of reliability the failure or malfunction of which may result in a direct threat to human life or create a risk of human injury (such as a medical instrument, transportation equipment, aerospace machinery, nuclear-reactor controller, fuel-controller or other safety device). ROHM shall bear no responsibility in any way for use of any of the Products for the above special purposes. If a Product is intended to be used for any such special purpose, please contact a ROHM sales representative before purchasing.

If you intend to export or ship overseas any Product or technology specified herein that may be controlled under the Foreign Exchange and the Foreign Trade Law, you will be required to obtain a license or permit under the Law.



Thank you for your accessing to ROHM product informations.
More detail product informations and catalogs are available, please contact us.

ROHM Customer Support System

<http://www.rohm.com/contact/>

Компания «Life Electronics» занимается поставками электронных компонентов импортного и отечественного производства от производителей и со складов крупных дистрибьюторов Европы, Америки и Азии.

С конца 2013 года компания активно расширяет линейку поставок компонентов по направлению коаксиальный кабель, кварцевые генераторы и конденсаторы (керамические, пленочные, электролитические), за счёт заключения дистрибьюторских договоров

Мы предлагаем:

- Конкуренеспособные цены и скидки постоянным клиентам.
- Специальные условия для постоянных клиентов.
- Подбор аналогов.
- Поставку компонентов в любых объемах, удовлетворяющих вашим потребностям.
- Приемлемые сроки поставки, возможна ускоренная поставка.
- Доставку товара в любую точку России и стран СНГ.
- Комплексную поставку.
- Работу по проектам и поставку образцов.
- Формирование склада под заказчика.
- Сертификаты соответствия на поставляемую продукцию (по желанию клиента).
- Тестирование поставляемой продукции.
- Поставку компонентов, требующих военную и космическую приемку.
- Входной контроль качества.
- Наличие сертификата ISO.

В составе нашей компании организован Конструкторский отдел, призванный помогать разработчикам, и инженерам.

Конструкторский отдел помогает осуществить:

- Регистрацию проекта у производителя компонентов.
- Техническую поддержку проекта.
- Защиту от снятия компонента с производства.
- Оценку стоимости проекта по компонентам.
- Изготовление тестовой платы монтаж и пусконаладочные работы.



Тел: +7 (812) 336 43 04 (многоканальный)

Email: org@lifeelectronics.ru