

## Pmod HYGRO Reference Manual

Revised February 22, 2017

This manual applies to the Pmod HYGRO rev. A

### Overview

The Digilent Pmod HYGRO (Revision A) is small relative humidity and temperature sensor. With the [TI HDC1080](#), you can determine the relative humidity of the environment with up to 14 bits of resolution.

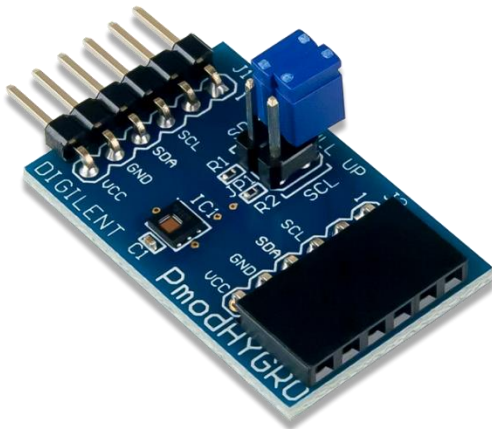

The Pmod HYGRO.

#### Features:

- Relative humidity accuracy  $\pm 2\%$
- Temperature sensor accuracy  $0.2\text{ }^{\circ}\text{C}$
- Good stability at high humidity
- 14-bit measurement resolution
- Internal resistive heating element
- 6-pin Pmod connector with I<sup>2</sup>C interface
- Pass-through Pmod host port for daisy chaining

## 1 Functional Description

The Pmod HYGRO is designed to digitally report the relative humidity and ambient temperature upon request by the host board. Up to 14-bits of resolution for each sensor may be collected by allowing for longer conversion times. A resistive heating element can be enabled to drive off condensation that accumulates on the sensor after being exposed at high humidity conditions.

## 2 Specifications

Parameter	Min	Typical	Max	Units
Power Supply Voltage	2.7	3	5.5	V
Serial Clock Frequency	10		400	kHz

Parameter	Value	Units
RH Accuracy	±2	%RH
RH Repeatability	±0.1	%RH
RH Hysteresis	±1	%RH
RH Response Time	15	sec
Temperature Accuracy	±0.2	°C
Sleep Mode Current Draw	100	nA

## 3 Interfacing with the Pmod

The Pmod HYGRO communicates with the host board via the [I<sup>2</sup>C protocol](#). By first sending the 7-bit I<sup>2</sup>C address of 1000000 (0x40) and then a read/write bit (high/low logic level, respectively), followed by the register address of interest at a maximum clock frequency of 400 kHz, users can both configure and read from the Pmod HYGRO. Header J2 on the Pmod HYGRO passes through all of the signals present on the main Header J1 to allow for the daisy chaining of multiple I<sup>2</sup>C compatible modules.

### 3.1 Configuration Register

The Configuration register (address 0x02) allows users to control the resolution of the temperature and humidity measurements, change the acquisition mode, enable the heater, and more. A table of the 16-bit register, recreated from Table 4 in the [HDC1080 datasheet](#), is provided below.

Bit Name	Bit Number	Bit Description	Bit Values	Functional Description
RST	[15]	Software reset bit	0 <sup>1</sup>	Normal Operation, this bit self clears
			1	Software Reset
Reserved	[14]	Reserved	0	Reserved, must be 0
HEAT	[13]	Heater	0 <sup>1</sup>	Heater Disabled
			1	Heater Enabled
MODE	[12]	Acquisition Mode	0	Temperature or Humidity is acquired depending on which register you choose to read
			1 <sup>1</sup>	Temperature and Humidity are acquired in sequence, with the Temperature first
BTST	[11]	Battery Status	0 <sup>1</sup>	Battery voltage (Vdd) > 2.8V (read only)
			1	Battery voltage (Vdd) < 2.8V (read only)
TRES	[10]	Temperature Measurement Resolution	0 <sup>1</sup>	14 bit
			1	11 bit
HRES	[9:8]	Humidity Measurement Resolution	00 <sup>1</sup>	14 bit
			01	11 bit
			10	8 bit
Reserved	[7:0]	Reserved	0	Reserved, must be 0

<sup>1</sup> This is the default value on power-up or reset.

Table 3. Configuration register description (Address 0x02).

## 3.2 Temperature and Humidity Registers

The temperature register (address 0x00) and the humidity register (address 0x01) are both 16-bit read only registers with the 14 MSBs corresponding to the 14-bit maximum resolution for both sensors. The two LSBs (bits D1 and D0) are always 0 for both registers. As the measurement resolution increases, the corresponding conversion time for each sensor also increases. A table of typical conversion times from Section 7.5 (Electrical Characteristics) of the [HDC1080 datasheet](#), is provided below.

Relative Humidity Sensor		Temperature sensor	
8-bit resolution	2.50 ms	11-bit resolution	3.65 ms
11-bit resolution	3.85 ms	14-bit resolution	6.35 ms
14-bit resolution	6.50 ms		

Table 4. Typical conversion times.

Upon device power-up, the Pmod HYGRO requires at least 15 ms prior to being able to perform a measurement. To perform a measurement, users need to configure (or accept) the measurement settings in the Configuration Register, and then trigger the measurement(s) by sending an I<sup>2</sup>C write transaction along with the address pointer set to the appropriate register. After waiting the appropriate conversion times listed in Table 4 above, users may then perform a read transaction, taking advantage of the auto-incrementing pointer address for reading both the temperature and humidity registers. After the data has been read, users need to wait at least one full second before performing another read transaction to avoid internal heating of the sensor and the distortion of the measured temperature and humidity levels.

Note that if a write transaction is performed on either the temperature (address 0x00) or humidity (address 0x01) registers during a conversion, the current conversion will be aborted and a new one started. If a read is performed during a conversion, the Pmod HYGRO will respond back with a [NACK](#) indicating the measurement result is not yet available. The typical time that it takes the output of the humidity sensor to show 63% of a step change in humidity is 15 seconds.

## 3.3 Quick Data Acquisition

Here is the series of commands to acquire relative humidity and temperature data from the Pmod HYGRO in pseudo I<sup>2</sup>C code.

1. Power on the Pmod HYGRO and wait at least 15 ms.
2. Call the device ID with a write bit

```
I2CBegin(0x80); //device ID 0x40 with a write (0) bit
```

3. Wait to receive an ACK from the Slave Device
4. Write the device address that you want to talk to

```
I2CWrite(0x00); //address 0x00 corresponds to the Temperature Register, the
Humidity register will be auto-incremented to next
```

5. Wait to receive an ACK from the Slave Device
6. Delay at least 12.85 ms (6.35 ms for the Temperature Sensor and 6.50 ms for the Humidity Sensor)
7. Read 4 bytes from the temperature and humidity registers (two 8 byte samples from each, MSB then LSB)

```
I2CReadMultiple(4); //read four bytes, sending an ACK to the slave after each
byte received and a NACK after the last byte
```

- Convert the readings into usable data. Note that the two LSBs (D1 and D0) will always be set to a value of 0. Only the upper 14-bits in each register contains the relevant data

$$Temperature (^{\circ}C) = \frac{Temperature [15:00]}{2^{16}} * 165^{\circ}C - 40^{\circ}C$$

$$Relative Humidity (\%RH) = \frac{Humidity Register [15:0]}{2^{16}} * 100\%RH$$

- Wait at least one full second before initiating another reading to avoid internal heating of the humidity sensor.

### 3.4 Pinout Table Diagram

Header J1			Header J2			Jumper Blocks		
Pin	Signal	Description	Pin	Signal	Description	Jumper	State	Description
1	NC	Not Connected	1	NC	Not Connected	JP1	Both Enabled	2.2 kΩ resistors enabled on the SDA and SCL lines
2	NC	Not Connected	2	NC	Not Connected	JP1	Both Disabled	2.2 kΩ resistors disabled on the SDA and SCL lines
3	SCL	Serial Clock	3	SCL	Serial Clock			
4	SDA	Serial Data	4	SDA	Serial Data			
5	GND	Power Supply Ground	5	GND	Power Supply Ground			
6	VCC	Power Supply (3.3V/5V)	6	VCC	Power Supply (3.3V/5V)			

The Pmod HYGRO is an ideal Pmod to use in long term humidity test application. As a very low power Pmod between measurements, long term data to measure humidity changes in an environment can easily be collected.

Any external power applied to the Pmod HYGRO must be within 2.7V and 5.5V to ensure that the on-board chips operate correctly; however, it is recommended that Pmod is operated at 3.3V.

### 3.5 Timing Diagram

A sample timing diagram for writing to and reading from the Pmod HYGRO taken from the HDC1080 datasheet are provided below:

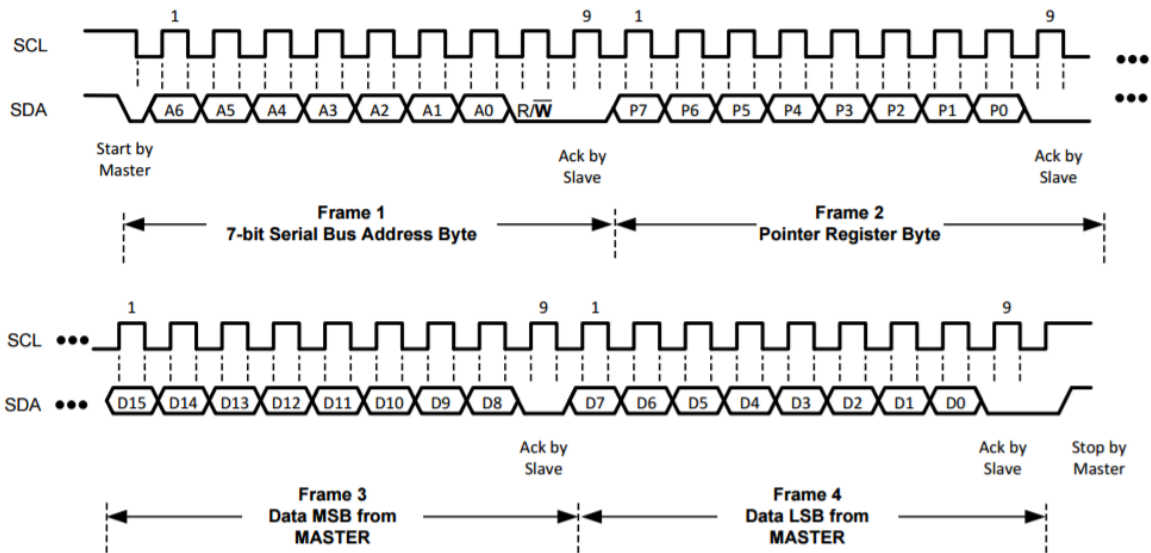

Figure 1. Example write to the Pmod HYGRO (from the HDC1080 datasheet).

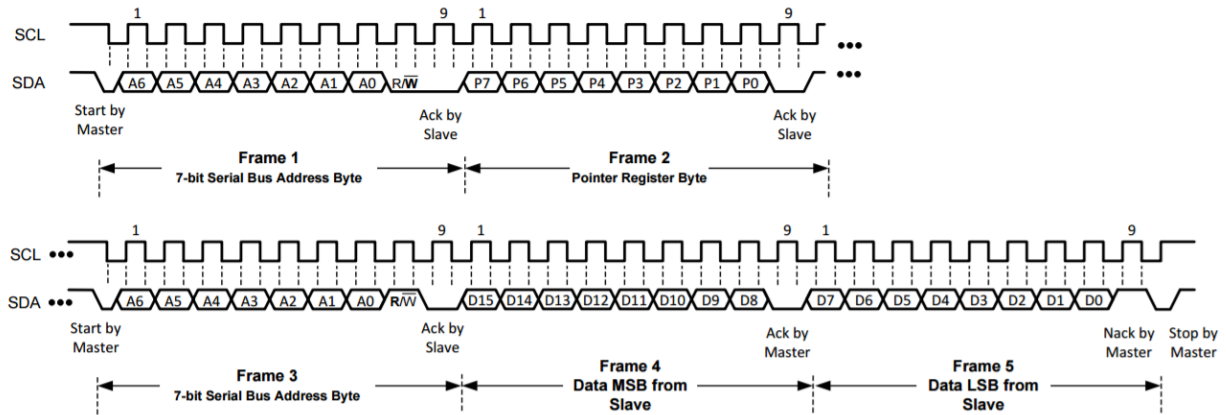

Figure 2. Example reading from the Pmod HYGRO (from the HDC1080 datasheet).

## 4 Physical Dimensions

The pins on the pin header are spaced 100 mil apart. The PCB is 1.25 inches long on the sides parallel to the pins on the pin header and 0.8 inches long on the sides perpendicular to the pin header.

## 5 Additional Information

The schematics of the Pmod HYGRO are available [here](#). Additional information about the humidity sensor including communication modes and specific timings of the chip can be found by checking out its datasheet [here](#).

More specific information about how to use the Pmod HYGRO can be found by checking out the additional resources on the Pmod HYGRO [Resource Center](#).

If you have any questions or comments about the Pmod HYGRO, feel free to post them under the appropriate section (“Add-on Boards”) of the [Diligent Forum](#).

Компания «Life Electronics» занимается поставками электронных компонентов импортного и отечественного производства от производителей и со складов крупных дистрибьюторов Европы, Америки и Азии.

С конца 2013 года компания активно расширяет линейку поставок компонентов по направлению коаксиальный кабель, кварцевые генераторы и конденсаторы (керамические, пленочные, электролитические), за счёт заключения дистрибьюторских договоров

Мы предлагаем:

- Конкурентоспособные цены и скидки постоянным клиентам.
- Специальные условия для постоянных клиентов.
- Подбор аналогов.
- Поставку компонентов в любых объемах, удовлетворяющих вашим потребностям.
- Приемлемые сроки поставки, возможна ускоренная поставка.
- Доставку товара в любую точку России и стран СНГ.
- Комплексную поставку.
- Работу по проектам и поставку образцов.
- Формирование склада под заказчика.
- Сертификаты соответствия на поставляемую продукцию (по желанию клиента).
- Тестирование поставляемой продукции.
- Поставку компонентов, требующих военную и космическую приемку.
- Входной контроль качества.
- Наличие сертификата ISO.

В составе нашей компании организован Конструкторский отдел, призванный помогать разработчикам, и инженерам.

Конструкторский отдел помогает осуществить:

- Регистрацию проекта у производителя компонентов.
- Техническую поддержку проекта.
- Защиту от снятия компонента с производства.
- Оценку стоимости проекта по компонентам.
- Изготовление тестовой платы монтаж и пусконаладочные работы.



Тел: +7 (812) 336 43 04 (многоканальный)

Email: [org@lifeelectronics.ru](mailto:org@lifeelectronics.ru)