

11-BIT PARALLEL TO SERIAL CONVERTER

■ GENERAL DESCRIPTION

The **NJU3754** is an 11-bit parallel to serial converter especially applying to MCU input port expander. It can operate from 2.7V to 5.5V.

The **NJU3754** requires only 3-port of MCU for data transmission and realizes the effective input port assignment.

The status of the input ports is output through a latch circuit, a shift register and a 3-state buffer as the serial data synchronizing with the serial clock. The hysteresis input circuit of the serial clock terminal realizes 5MHz and more operation.

Furthermore, pull-up resistors on chip of P0 to P10 terminals reduce external components for key-scan circuit, etc.

■ PACKAGE OUTLINE

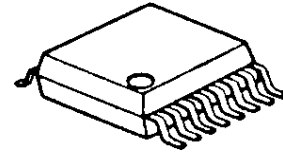
NJU3754V

■ FEATURES

- 11-Bit Parallel In Serial Out
- 3-line Serial Interface Output
- Hysteresis Input 0.5V typ at 5V
- Maximum Operating Frequency 5MHz and more
- Operating Voltage 2.7 to 5.5V
- C-MOS Technology
- Package Outline SSOP16

■ PIN CONFIGURATION

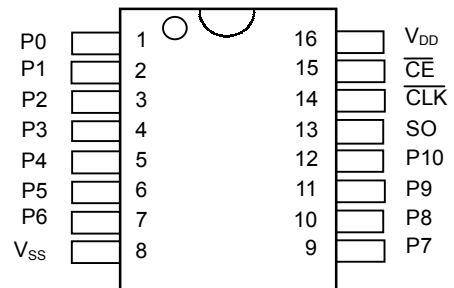

■ BLOCK DIAGRAM

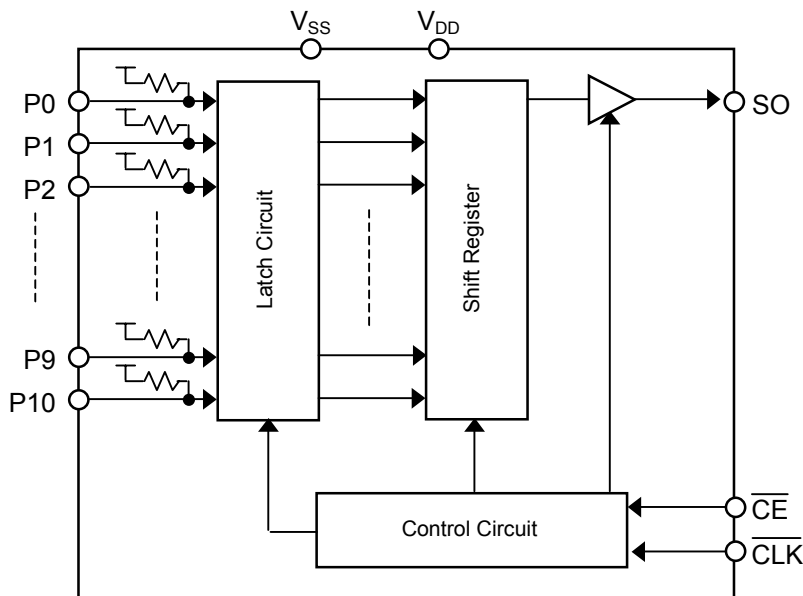

■ TERMINAL DESCRIPTION

No.	SYMBOL	I/O	FUNCTION
1	P0	I	Parallel Data Input Terminals (with pull-up resistors)
2	P1	I	
3	P2	I	
4	P3	I	
5	P4	I	
6	P5	I	
7	P6	I	
8	V _{SS}	-	Ground
9	P7	I	Parallel Data Input Terminals (with pull-up resistors)
10	P8	I	
11	P9	I	
12	P10	I	
13	SO	O	Serial Data Output Terminal
14	CLK	I	Serial Clock Input Terminal
15	$\overline{\text{CE}}$	I	Chip Enable Input Terminal
16	V _{DD}	-	Power Supply Terminal (2.7 to 5.5V)

■ FUNCTIONAL DESCRIPTION

At the falling edge of $\overline{\text{CE}}$ terminal, the status of P0 to P10 terminal is latched and transferred to the shift register. At the mean time, the P0 data is output from SO terminal. While $\overline{\text{CE}}$ terminal is "L", the data from P1 to P10 in the shift register are synchronized with the falling edge of CLK terminal and output from SO terminal.

When $\overline{\text{CE}}$ terminal is "H", SO terminal is high impedance.

Note 1) If the 11th falling edge and later are input to CLK terminal while $\overline{\text{CE}}$ is "L", the 12th and the following data are invalid.

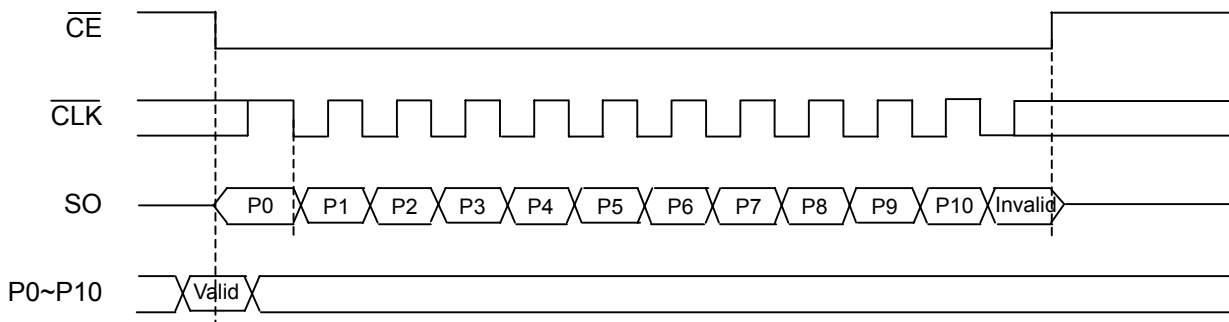

■ ABSOLUTE MAXIMUM RATINGS

(Ta=25°C)

PARAMETER	SYMBOL	RATINGS	UNIT
Supply Voltage Range	V_{DD}	-0.3 ~ +7.0	V
Input Voltage Range	V_I	$V_{SS}-0.3 \sim V_{DD}+0.3$	V
Power Dissipation	P_D	300 (SSOP)	mW
Operating Temperature Range	Topr	-40 ~ +85	°C
Storage Temperature Range	Tstg	-65 ~ +150	°C

Note 2) All voltage are relative to $V_{SS}=0V$ reference.

Note 3) Do not exceed the absolute maximum ratings, otherwise the stress may cause a permanent damage to the IC. It is also recommended that the IC is used in the range specified in the DC electrical characteristics, or the electrical stress may cause malfunctions and impact on the reliability.

Note 4) To stabilize the IC operation, place decoupling capacitor between V_{DD} - V_{SS} .

■ DC ELECTRICAL CHARACTERISTICS

($V_{DD}=2.7\sim 5.5V$, $V_{SS}=0V$, $T_a=25^\circ C$, unless otherwise noted)

PARAMETER	SYMBOL	CONDITION	MIN	TYP	MAX	UNIT	
Operating Voltage	V_{DD}		2.7	-	5.5	V	
Operating Current	I_{DD}	$V_{DD}=5.5V$ P0~P10=Open $\overline{CE}=H$, $\overline{CLK}=L$ SO=No load	-	-	10	μA	
Input Voltage	V_{IH}	P0~P10, \overline{CLK} , \overline{CE} Terminals	$0.7V_{DD}$	-	V_{DD}	V	
	V_{IL}		V_{SS}	-	$0.3V_{DD}$	V	
High-level Input Current	I_{IH}	$V_{DD}=5V$, $V_I=5V$ P0~P10, \overline{CLK} , \overline{CE} Terminals	-	-	1	μA	
Low-level Input Current 1	I_{IL1}	$V_{DD}=5V$, $V_I=0V$ \overline{CLK} , \overline{CE} Terminals	-1	-	-	μA	
Low-level Input Current 2	I_{IL2}	$V_{DD}=5V$, $V_I=0V$ P0~P10 Terminals	-100	-40	-15	μA	
Output Voltage	V_{OH}	$I_{OH}=-0.4mA$	SO Terminal	$V_{DD}-0.4$	-	V_{DD}	V
	V_{OL}	$I_{OL}=+3.2mA$		V_{SS}	-	0.4	V
3-State Leakage Current	I_{TSL}	SO Terminal $\overline{CE}=H$	-2	-	2	μA	

■ SWITCHING CHARACTERISTICS

($V_{DD}=2.7\sim 5.5V$, $V_{SS}=0V$, $T_a=25^\circ C$, unless otherwise noted)

PARAMETER	SYMBOL	CONDITION	MIN	TYP	MAX	UNIT
\overline{CLK} Cycle Time	t_{CYC}	\overline{CLK}	200	-	-	ns
\overline{CLK} Pulse Width (H)	t_{WCH}	\overline{CLK}	90	-	-	ns
\overline{CLK} Pulse Width (L)	t_{WCL}	\overline{CLK}	90	-	-	ns
\overline{CE} Pulse Width (H)	t_{WEH}	\overline{CE}	100	-	-	ns
\overline{CE} Set-up Time before \overline{CLK} Falling	t_{SS}	$\overline{CE} - \overline{CLK}$	100	-	-	ns
\overline{CE} Hold Time after \overline{CLK} Falling	t_{HS}	$\overline{CLK} - \overline{CE}$	100	-	-	ns
Parallel Data Set-up Time	t_{SPL}	P0~P10 - \overline{CE}	50	-	-	ns
Parallel Data Hold Time	t_{HPL}	$\overline{CE} - P0\sim P10$	50	-	-	ns
SO Delay Time after \overline{CE} Falling	t_{DSL}	$\overline{CE} - SO$ (Note 6)	-	-	50	ns
SO Delay Time after \overline{CLK} Falling	t_{DSS}	$\overline{CLK} - SO$ (Note 6)	-	-	50	ns
SO Hold Time after \overline{CE} Rising	t_{DSZ}	$\overline{CE} - SO$ (Note 6)	-	-	20	ns
Rise Time	t_R	\overline{CLK} Terminal	-	-	20	ns
Fall Time	t_F	\overline{CLK} , \overline{CE} Terminals	-	-	20	ns

Note 5) A 15k Ω pull-up or pull-down resistor and a 50pF capacitor on the SO terminal.

Note 6) All timings are based on 30% and 70% voltage level of V_{DD} .

■ TIMING CHARTS

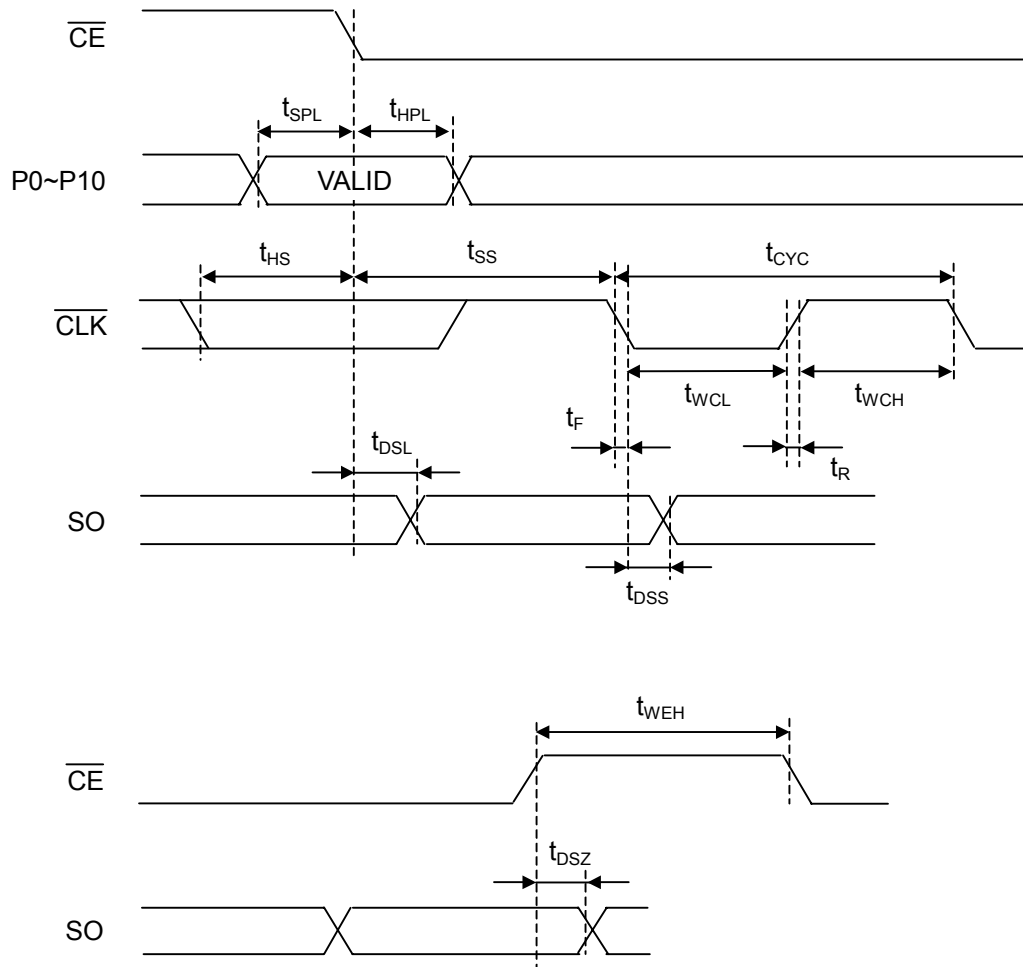

NJU3754

■ APPLICATION CIRCUIT

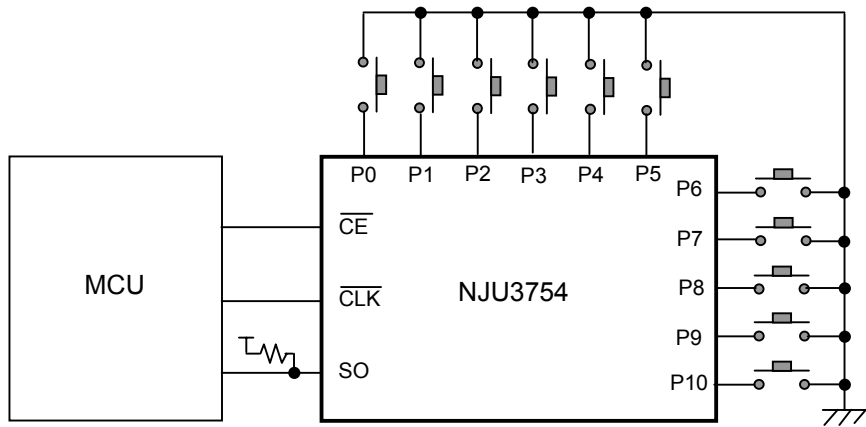

[CAUTION]
The specifications on this databook are only given for information, without any guarantee as regards either mistakes or omissions. The application circuits in this databook are described only to show representative usages of the product and not intended for the guarantee or permission of any right including the industrial rights.

Mouser Electronics

Authorized Distributor

Click to View Pricing, Inventory, Delivery & Lifecycle Information:

[NJR:](#)

[NJU3754V-TE1](#)

Компания «Life Electronics» занимается поставками электронных компонентов импортного и отечественного производства от производителей и со складов крупных дистрибьюторов Европы, Америки и Азии.

С конца 2013 года компания активно расширяет линейку поставок компонентов по направлению коаксиальный кабель, кварцевые генераторы и конденсаторы (керамические, пленочные, электролитические), за счёт заключения дистрибьюторских договоров

Мы предлагаем:

- Конкурентоспособные цены и скидки постоянным клиентам.
- Специальные условия для постоянных клиентов.
- Подбор аналогов.
- Поставку компонентов в любых объемах, удовлетворяющих вашим потребностям.
- Приемлемые сроки поставки, возможна ускоренная поставка.
- Доставку товара в любую точку России и стран СНГ.
- Комплексную поставку.
- Работу по проектам и поставку образцов.
- Формирование склада под заказчика.
- Сертификаты соответствия на поставляемую продукцию (по желанию клиента).
- Тестирование поставляемой продукции.
- Поставку компонентов, требующих военную и космическую приемку.
- Входной контроль качества.
- Наличие сертификата ISO.

В составе нашей компании организован Конструкторский отдел, призванный помогать разработчикам, и инженерам.

Конструкторский отдел помогает осуществить:

- Регистрацию проекта у производителя компонентов.
- Техническую поддержку проекта.
- Защиту от снятия компонента с производства.
- Оценку стоимости проекта по компонентам.
- Изготовление тестовой платы монтаж и пусконаладочные работы.



Тел: +7 (812) 336 43 04 (многоканальный)

Email: org@lifeelectronics.ru