



TL SERIES PHOTOCONTROL

THERMAL, SLIM PROFILE, WIRE-IN DESIGN

KEY FEATURES

- Adjustable swivel base
- Thin line profile-perfect for tight spots
- UL Listed and CSA Certified
- Durable polycarbonate housing
- 30 - 45 second time delay
- Fail mode is ON

TE Connectivity's (TE) TL Series provides a slim profile ideal for installation in compact areas. An adjustable swivel base design allows maximum installation flexibility. TE innovative cylindrical design will fit between twin flood lights and in other tight applications.

The TL Series photocontrol is constructed of a high impact UV stabilized polycarbonate housing for superior quality. Controls are also equipped with a field adjustable swivel base that makes it easy to direct the photocell away from stray light.

The TL Series also has a heavy-duty bi-metal switch that provides a 30 - 45 second time delay virtually eliminating unwanted lamp cycling caused by lightning, car headlights, or other sudden changes in ambient light level.

Customers can count on consistent, high quality products, driven by TE's proven innovation and backed by our extraordinary customer support.



TE's photocontrols can be used to safely control luminaries with incandescent, HID, LED, or compact fluorescent lamps.

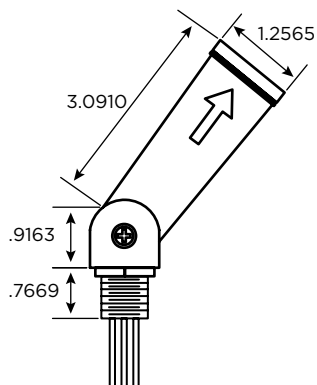

PRODUCT SELECTION INFORMATION						
Description	Rated Volts	Range (Volts)	Load Rating Tungsten (Watts)	Load Rating Ballast (VA)	Turn ON (Fc)	OFF/ON Ratio
TL-115	120	105 - 130	1800	1100	1.5	4 : 1
TL-1168	208/240/277	185 - 305	1200	1100	1.5	4 : 1

Note: 6" lead wires

SPECIFICATION	
Physical	Enclosure: designed to meet UL 773A
	Power consumption: less than 0.9 watts (avg.) at 120 VAC
Temperature	Minus 40°C to plus 65°C at 96% RH
Light Sensor	Cadmium Sulfide Cell

TECHNICAL INFORMATION	
Switch	SPST thermal bi-metallic, exceeds 5,000 ON/OFF
Fail Mode	ON (contacts normally closed)
Housing	Polycarbonate with UV stabilized window
Lead Wires	6", #18 AWG, rated 105°C
Nipple	1/2" pipe
Nut	1/2" pipe, die-cast



te.com/energy

©2008, 2012, 2014 TE Connectivity Ltd. family of companies. All Rights Reserved. 9-1773453-0 E332 10/2014

TE Connectivity and TE connectivity (logo) are trademarks. Other logos, product and/or company names might be trademarks of their respective owners. While TE has made every reasonable effort to ensure the accuracy of the information in this brochure, TE does not guarantee that it is error-free, nor does TE make any other representation, warranty or guarantee that the information is accurate, correct, reliable or current. TE reserves the right to make any adjustments to the information contained herein at any time without notice. TE expressly disclaims all implied warranties regarding the information contained herein, including, but not limited to, any implied warranties of merchantability or fitness for a particular purpose. The dimensions in this catalog are for reference purposes only and are subject to change without notice. Specifications are subject to change without notice. Consult TE for the latest dimensions and design specifications.

FOR MORE INFORMATION: TE Technical Support Centers

- USA: + 1 800 327 6996
- France: + 33 380 583 200
- UK: + 44 0870 870 7500
- Germany: + 49 896 089 903
- Spain: + 34 916 630 400
- Benelux: + 32 16 351 731
- Canada: + 1 (905) 475-6222
- Mexico: + 52 (0) 55-1106-0800
- Latin/S. America: + 54 (0) 11-4733-2200
- China: + 86 (0) 400-820-6015

Компания «Life Electronics» занимается поставками электронных компонентов импортного и отечественного производства от производителей и со складов крупных дистрибьюторов Европы, Америки и Азии.

С конца 2013 года компания активно расширяет линейку поставок компонентов по направлению коаксиальный кабель, кварцевые генераторы и конденсаторы (керамические, пленочные, электролитические), за счёт заключения дистрибьюторских договоров

Мы предлагаем:

- Конкурентоспособные цены и скидки постоянным клиентам.
- Специальные условия для постоянных клиентов.
- Подбор аналогов.
- Поставку компонентов в любых объемах, удовлетворяющих вашим потребностям.
- Приемлемые сроки поставки, возможна ускоренная поставка.
- Доставку товара в любую точку России и стран СНГ.
- Комплексную поставку.
- Работу по проектам и поставку образцов.
- Формирование склада под заказчика.
- Сертификаты соответствия на поставляемую продукцию (по желанию клиента).
- Тестирование поставляемой продукции.
- Поставку компонентов, требующих военную и космическую приемку.
- Входной контроль качества.
- Наличие сертификата ISO.

В составе нашей компании организован Конструкторский отдел, призванный помогать разработчикам, и инженерам.

Конструкторский отдел помогает осуществить:

- Регистрацию проекта у производителя компонентов.
- Техническую поддержку проекта.
- Защиту от снятия компонента с производства.
- Оценку стоимости проекта по компонентам.
- Изготовление тестовой платы монтаж и пусконаладочные работы.



Тел: +7 (812) 336 43 04 (многоканальный)

Email: org@lifeelectronics.ru