

Repeater power supply - PI-EX-RPSS - 2865243

Please be informed that the data shown in this PDF Document is generated from our Online Catalog. Please find the complete data in the user's documentation. Our General Terms of Use for Downloads are valid (<http://phoenixcontact.com/download>)



Ex i analog input: Repeater power supply, HART. Feeds intrinsically safe 2-conductor measuring transducers installed in an Ex area and transmits the 4-20 mA signal to a load in a safe area. Galvanic 3-way isolation (input / output / supply).



Key Commercial Data

Packing unit	1 pc
GTIN	 4 046356 164290
GTIN	4046356164290

Technical data

Note

Utilization restriction	EMC: class A product, see manufacturer's declaration in the download area
-------------------------	---

Dimensions

Width	12.4 mm
Height	145 mm
Depth	147 mm

Ambient conditions

Ambient temperature (operation)	-20 °C ... 60 °C
Ambient temperature (storage/transport)	-40 °C ... 80 °C
Permissible humidity (operation)	10 % ... 95 % (non-condensing)

Input data

Signal input	Intrinsically safe
Current input signal	4 mA ... 20 mA
Transmitter supply voltage	> 16 V (at 20 mA)
	> 15.3 V (at 22.5 mA)

Repeater power supply - PI-EX-RPSS - 2865243

Technical data

Output data

Signal output	Current output
Current output signal	4 mA ... 20 mA (active)
	4 mA ... 20 mA (14 ... 26 V ext. source voltage)
Load/output load current output	< 600 Ω (at 20 mA)
	< 525 Ω (at 22.5 mA)
Output ripple	< 20 mV _{rms}
Output behavior in the event of an error	0 mA (Cable break in the input)
	≥ 24 mA (Cable short-circuit in the input)

Power supply

Supply voltage range	19.2 V DC ... 30 V DC
Max. current consumption	< 60 mA (at 24 V DC)
Power dissipation	< 1.1 W (at 24 V DC / 20 mA)

General

No. of channels	1
Maximum transmission error	< 0.1 % (of final value)
Transmission error, typical	< 0.05 % (of final value)
Maximum temperature coefficient	< 0.01 %/K
Step response (10-90%)	< 600 μs (for 4 mA ... 20 mA step)
Status display	Green LED (supply voltage, PWR)
Flammability rating according to UL 94	V0
Degree of pollution	2
Overvoltage category	II
Housing material	PBT and polyamide PA non-reinforced
Color	green
Designation	Input/output/power supply
Electrical isolation	300 V _{rms} (Rated insulation voltage (overvoltage category II; degree of pollution 2, safe isolation as per EN 61010-1))
	2.5 kV (50 Hz, 1 min., test voltage)
Designation	Input/output
Electrical isolation	375 V (Peak value in accordance with EN 60079-11)
Designation	Input/power supply
Electrical isolation	375 V (Peak value in accordance with EN 60079-11)
Conformance	CE-compliant, additionally EN 61326
ATEX	# II (1) G [Ex ia] IIC
	# II (1) D [Ex iaD]
	# II 3 (1) G Ex nA [ia] IIC T4
Functional Safety (SIL)	SIL 2 according to IEC 61508
SIL	2

Data communication (bypass)

Repeater power supply - PI-EX-RPSS - 2865243

Technical data

Data communication (bypass)

HART function	Yes
Protocols supported	HART

Safety characteristic data

Integrity requirement	IEC 61508 - Low demand
Designation	Repeater power supply operation
Equipment type	Type A
Safety Integrity Level (SIL)	2
Safe Failure Fraction (SFF)	90.9 %
λ_{SU}	1.51×10^{-7} (151 FIT)
λ_{SD}	0
λ_{DU}	4.1×10^{-8} (41 FIT)
λ_{DD}	2.63×10^{-7} (263 FIT)
Probability of a hazardous failure on demand (PFD _{AVG})	1.96×10^{-4} (1 year)
	3.74×10^{-4} (2 years)
	9.07×10^{-4} (5 years)
Diagnostic coverage (DC)	DC _S = 0%, DC _D = 86%
Integrity requirement	IEC 61508 - Low demand
Designation	Input isolating amplifier (4 ... 20 mA)
Equipment type	Type A
Safety Integrity Level (SIL)	2
Safe Failure Fraction (SFF)	91.2 %
λ_{SU}	1.52×10^{-7} (152 FIT)
λ_{SD}	0
λ_{DU}	3.8×10^{-8} (38 FIT)
λ_{DD}	2.44×10^{-7} (244 FIT)
Probability of a hazardous failure on demand (PFD _{AVG})	1.81×10^{-4} (1 year)
	3.46×10^{-4} (2 years)
	8.41×10^{-4} (5 years)
Diagnostic coverage (DC)	DC _S = 0%, DC _D = 86%

Safety data

Max. output voltage U _o	25.2 V
Max. output current I _o	93 mA
Max. output power P _o	590 mW
Group	IIB
Max. external inductivity L _o	4 mH
Max. external capacity C _o	820 nF
Group	IIC
Max. external inductivity L _o	2 mH

Repeater power supply - PI-EX-RPSS - 2865243

Technical data

Safety data

Max. external capacity C_o	107 nF
Safety-related maximum voltage U_m	253 V AC

Standards and Regulations

Flammability rating according to UL 94	V0
Conformance	CE-compliant, additionally EN 61326
ATEX	# II (1) G [Ex ia] IIC
	# II (1) D [Ex iaD]
	# II 3 (1) G Ex nA [ia] IIC T4
Group	IIB
	IIC

Environmental Product Compliance

China RoHS	Environmentally Friendly Use Period = 50
	For details about hazardous substances go to tab "Downloads", Category "Manufacturer's declaration"

Drawings

Block diagram

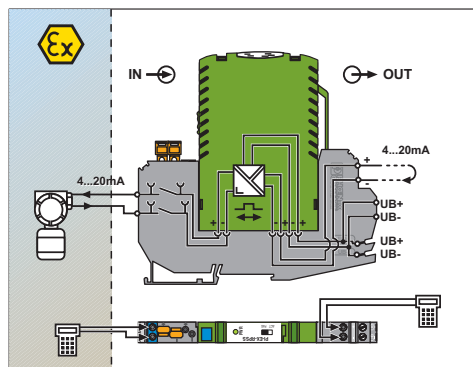

Dimensional drawing

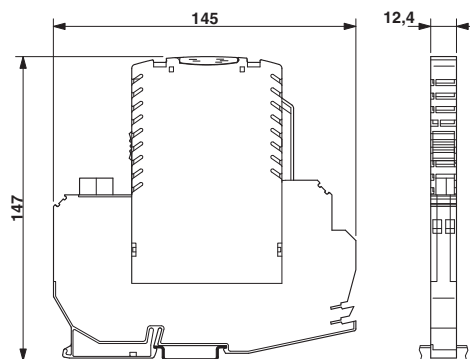

Approvals

Approvals

Approvals

Functional Safety

Ex Approvals

ATEX / EAC Ex

Repeater power supply - PI-EX-RPSS - 2865243

Approvals

Approval details

Functional Safety	09-06-52 R010 V1R0
-------------------	--------------------

Phoenix Contact 2018 © - all rights reserved
<http://www.phoenixcontact.com>

PHOENIX CONTACT GmbH & Co. KG
Flachsmarktstr. 8
32825 Blomberg
Germany
Tel. +49 5235 300
Fax +49 5235 3 41200
<http://www.phoenixcontact.com>

Компания «Life Electronics» занимается поставками электронных компонентов импортного и отечественного производства от производителей и со складов крупных дистрибьюторов Европы, Америки и Азии.

С конца 2013 года компания активно расширяет линейку поставок компонентов по направлению коаксиальный кабель, кварцевые генераторы и конденсаторы (керамические, пленочные, электролитические), за счёт заключения дистрибьюторских договоров

Мы предлагаем:

- Конкурентоспособные цены и скидки постоянным клиентам.
- Специальные условия для постоянных клиентов.
- Подбор аналогов.
- Поставку компонентов в любых объемах, удовлетворяющих вашим потребностям.
- Приемлемые сроки поставки, возможна ускоренная поставка.
- Доставку товара в любую точку России и стран СНГ.
- Комплексную поставку.
- Работу по проектам и поставку образцов.
- Формирование склада под заказчика.
- Сертификаты соответствия на поставляемую продукцию (по желанию клиента).
- Тестирование поставляемой продукции.
- Поставку компонентов, требующих военную и космическую приемку.
- Входной контроль качества.
- Наличие сертификата ISO.

В составе нашей компании организован Конструкторский отдел, призванный помогать разработчикам, и инженерам.

Конструкторский отдел помогает осуществить:

- Регистрацию проекта у производителя компонентов.
- Техническую поддержку проекта.
- Защиту от снятия компонента с производства.
- Оценку стоимости проекта по компонентам.
- Изготовление тестовой платы монтаж и пусконаладочные работы.



Тел: +7 (812) 336 43 04 (многоканальный)

Email: org@lifeelectronics.ru