

Relevant Products:

- CT219 Differential Current Sensor

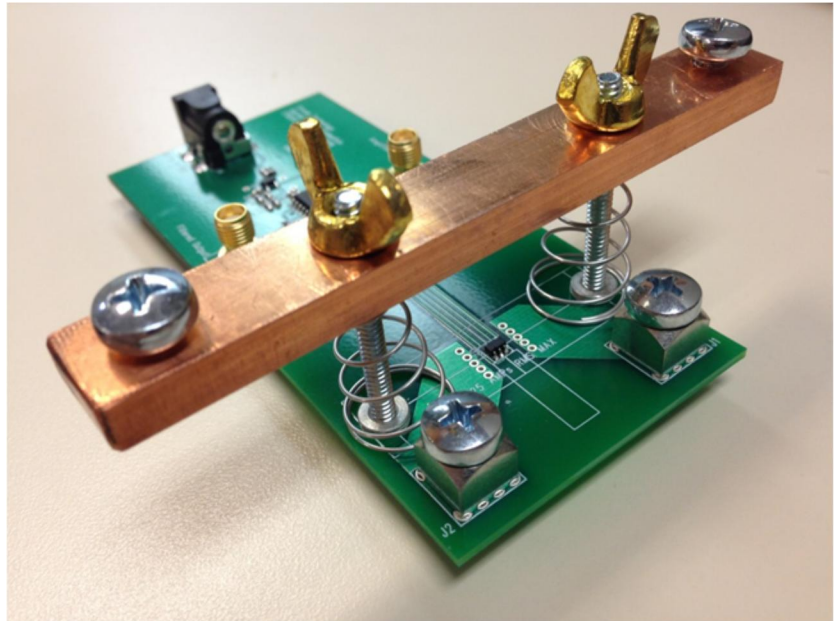

Introduction

This document provides general information about the design and use of the Crocus evaluation board for differential current sensing with either a current carrying trace and adjustable bus bar.

General Description

The CTD203 Differential Current Sensor Demonstration Board is designed to demonstrate the current sensing capabilities of the Crocus magnetic sensor for different ranges of currents. This demo board includes one CT219 current sensor that is used in differential mode. This sensor is physically mounted on top of the PCB over the current carrying trace and under a vertically adjustable bus bar. The bus bar height can be adjusted above the sensor, and there are two areas identified on the board which are marked for adding concentrators. With either AC or DC current passing through the bus bar, the sensor senses the magnetic flux generated by the current and provides an output voltage that is directly proportional to the current.

The CT219 sensor by nature is connected in a half-bridge configuration as part of a closed-loop circuit as shown in Figure 1. The output voltage of the half-bridge is used in the circuit to provide feedback currents to the inputs of the sensor setting the biasing point.

The PCB is designed with several test points and signal output points terminated by SMA connectors on the demo board. This allows the user to probe the circuit at every stage of the signal chain.

Closed-Loop Circuit

The closed-loop circuit shown in Figure 1 is designed to provide a feedback path for the bias current for CT219 sensor so that the device is kept at the same bias point. This is accomplished by first sensing the output voltage of the half-bridge circuit and then zeroing the sensor output by changing the input currents of the sensor. The feedback in the field line current is used to essentially cancel the effects of the external magnetic field and keep the sensor at the same bias point.

By way of circuit analysis, the CT219 sensor is comprised of a voltage divider (R_{s1} & R_{s2}) that is biased by the sensor supply (+5 VDC). In an initial state of no current on the trace (or the bus bar) and no external magnetic field, the sensor supply voltage is split by the differential sensor half-bridge circuit ($+5V / 2 = 2,500$ mV DC). This value changes as external current (external magnetic flux) flows through the trace. Therefore, to zero the output of each sensor exposed to the external magnetic field, the feedback currents will need to cancel, one to decrease and the other to increase.

For this purpose, output of the half-bridge is first buffered via U1A Op-Amp and then compared to a 2.5 VDC (generated with adjusting the POT) and amplified via U1B. Since the quiescent output of the half-bridge is approximately +2.5VDC, offset biasing is necessary prior to amplification. The potentiometer (R3) is used to zero the sensor offset voltage before amplification. The output of the amplifier is then fed back into the Crocus sensor in order to keep the sensors in their linear region.

The output signal of the comparing circuit (U1B) is the signal out of the closed-loop circuit.

A Sallen-Key low-pass filter monitors the output of the circuit.

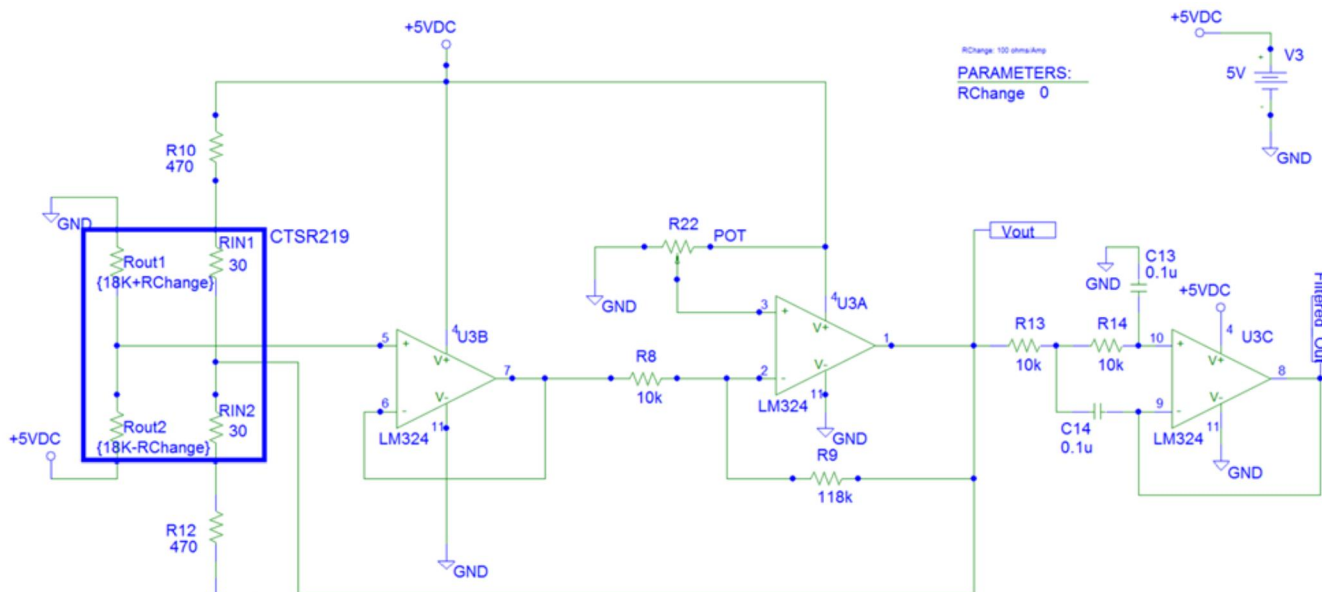
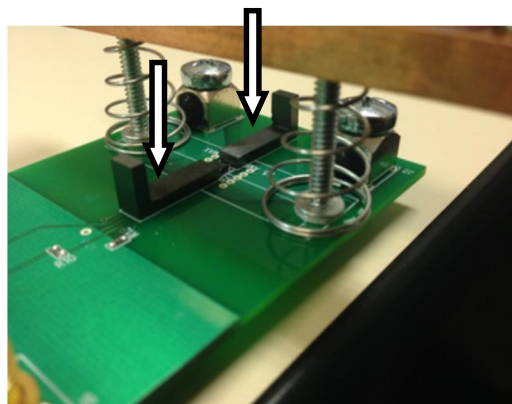
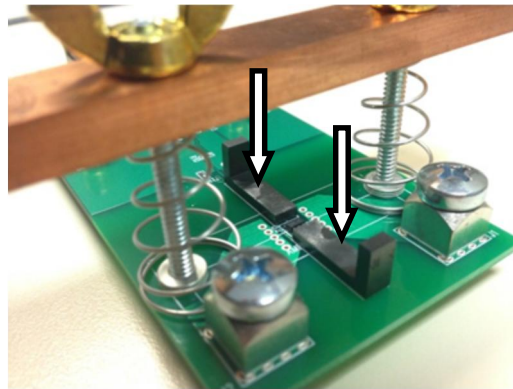

Figure 1: Closed-loop Circuit Schematic

Optional Concentrator for Increased Sensitivity

As an add-on option, two ferrite concentrators (depicted by the arrows) can be added to the sides of the sensor, as noted on the board, to increase the sensitivity of the board. The concentrators (the black L-shaped components below) will concentrate the lines of magnetic flux passing through the sensor in between the gap of the two ferrite concentrators. This technique is applicable to either the current carrying trace or the bus bar.



Set-up for Evaluation

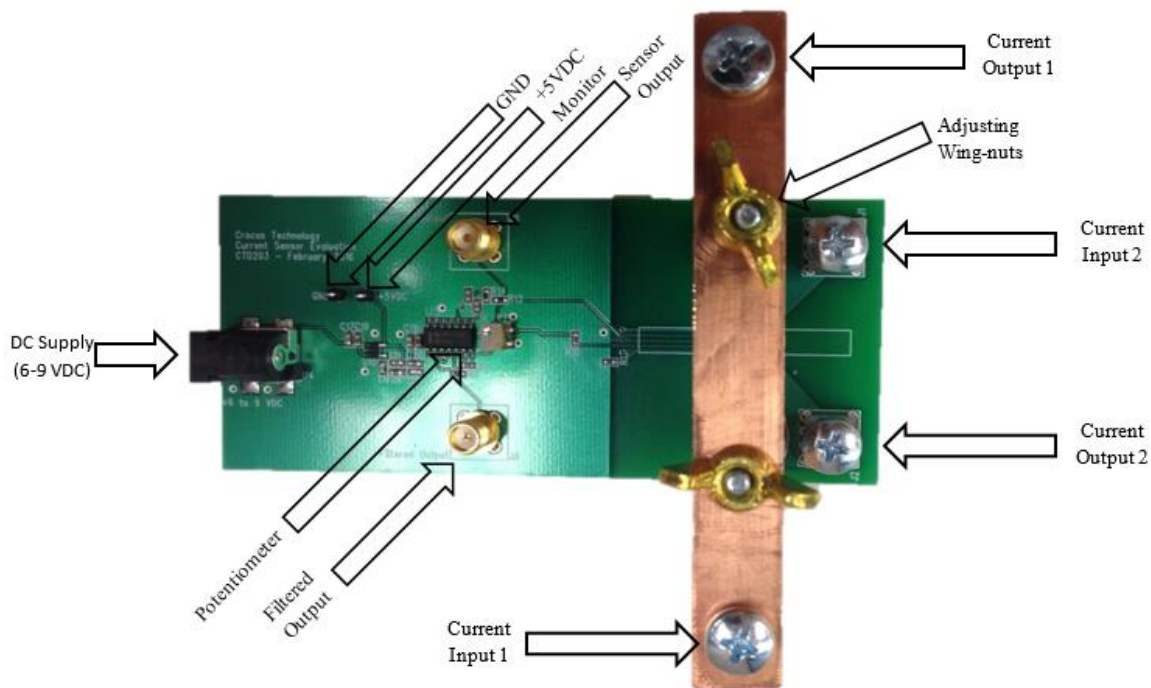

Figure 2: CTD203 Demo Board

The demo board set-up procedure is as follows:

1. Connect a DC source (+6 VDC to +9 VDC) to the DC connector labeled U4 on the board. There is a voltage regulator onboard that will convert the supplied power to the necessary voltages needed for the evaluation board.
2. Connect the current to be measured to the input terminal connector on the board (Either the Bus Bar or the Current Trace). The input current connector is labeled as "Current Input". **NOTE: DO NOT EXCEED 600 AMPS RMS ON THE BUS BAR.**
3. Complete the current circuit by connecting to the terminal referred to as the "Current Output" in the figure above (Either the Bus Bar or the Current Trace). The evaluation board will measure the current flowing from the "Current Input" to the "Current Output" terminals.
4. Connect an oscilloscope or a DVM (AC RMS) to the corresponding SMA connector (J5 Amplified Output, J6 Filtered Output) to measure output signals on the board as shown in Figure 3.
5. Adjust the distance of the bus bar from the sensors by turning the two wing-nuts simultaneously (Only when using the Bus Bar).

The demo board shown below illustrates the connections of the following inputs and outputs:

1. Connect an AC power adaptor with 6 – 9 VDC output voltage (>100mA) to U4.
2. A function generator or a suitable AC source is used to provide a sinusoidal input signal to the evaluation board. The function generator used should be able to deliver at least 100mA RMS of current to the evaluation board. The signal is applied to the input terminal of the PCB as shown below (Either the Bus Bar or the Current Trace).
3. Complete the current circuit by connecting the return of the current source to the current output connector shown below. (Either the Bus Bar or the Current Trace).
4. The output of the Crocus Differential Sensor Evaluation Board can be observed by connecting an oscilloscope to the SMA connectors labeled J5 and J6. To monitor the output of the closed-loop sensor circuit, connect the oscilloscope to J5. J6 can be used to measure the filtered output of the sensor circuit.

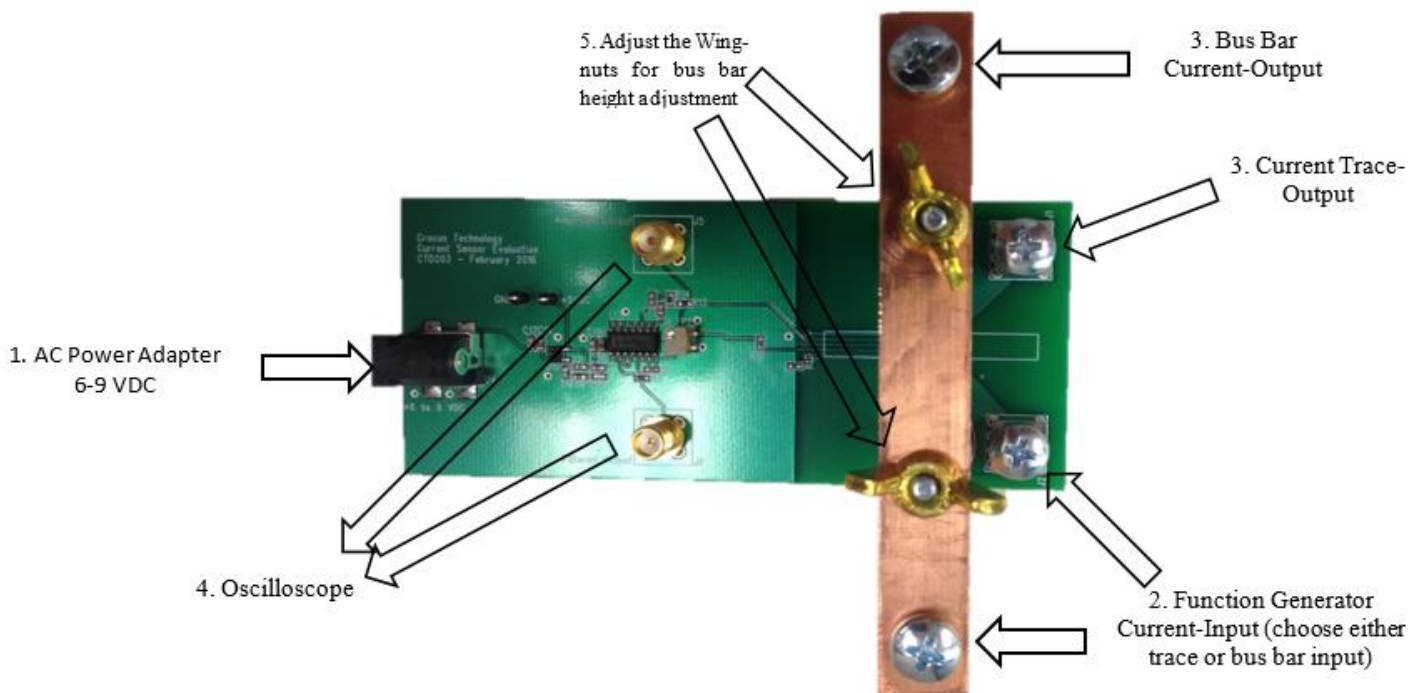

Figure 3: CTD203 Demo Board with Current Generator Input

Typical Closed-Loop Circuit Output Characteristics

Characteristics	Conditions	Min	Typical	Max	Units	Notes
DC Voltage Input		6		9	VDC	
Current Draw	6 VDC applied to DC Connector	5.71	5.806	5.85	mA	
Current Range		0		25	Amps	
Current Dynamic Range Ratio	Current sensing trace 1.6mm from sensor, Gain = 25		1136.36		Amps	2
Linearity		99.51	99.65	99.75	+/-% FS	
Resolution			20		mA	
Hysteresis			1		% FS	
Output Rate (ODR)			1000000		Hz	1
Sensitivity:			86.23		mV/A	4
Output Minimum			60	180	mV	1
Output Maximum		4.9	4.99		mV	1
Operating Temperature		-40		85	°C	
Average Temperature Coefficient of Output	Characterized from +25C to +85°C		0.46	0.83	mV/°C	
Noise Floor			50		μV _{RMS}	3

Note 1: Limited by the LMV324 operational amplifier (Unity-gain BW = 1MHz),
Crocus Sensor ODR = 500MHz

Note 2: Current DNR is equal to 1,000 : 1 Amps for current sensing trace/Bus 1.6mm from sensor. 1.3mm distance is from the current-carrying-trace to the bottom of the package. The sensitive element is ~0.3mm above the bottom of the package.
Gain on OpAmp driving the field lines is = 25x

Note 3: Noise floor per un-amplified sensor.

Note 4: Usage: $I = \Delta V_{out} / 0.08623$ [A]

Disclaimer: The contents of this document are provided in connection with products of Crocus Technology (Crocus). CROCUS TECHNOLOGY MAKES NO REPRESENTATIONS OR WARRANTY OF ANY KIND, EXPRESS OR IMPLIED, WITH RESPECT TO THE ACCURACY OR COMPLETENESS OF THE CONTENTS HEREIN, INCLUDING, BUT NOT LIMITED TO, THE IMPLIED WARRANTIES OF MERCHANTABILITY AND FITNESS FOR A PARTICULAR PURPOSE AND RESERVES THE RIGHT TO MAKE CHANGES TO THE SPECIFICATIONS AND PRODUCT DESCRIPTIONS AT ANY TIME WITHOUT NOTICE. Crocus reserves the right to discontinue or make changes to its products at any time without notice. Crocus's products have not been designed, tested, or manufactured for use and should not be used in applications where the failure, malfunction or inaccuracy of the Products carries a risk of death or serious bodily injury or damage to tangible property, including, but not limited to, life support systems, nuclear facilities, military, aircraft navigation or communication, emergency systems, harsh environments, or other applications with a similar degree of potential hazard.

ATTRIBUTION

© 2015 Crocus Technology, Inc. and Crocus Technology SA. All rights reserved. Crocus Technology, Blossoming Future, MLU, and combinations thereof are trademarks of Crocus Technology, Inc. and Crocus Technology SA.

Компания «Life Electronics» занимается поставками электронных компонентов импортного и отечественного производства от производителей и со складов крупных дистрибьюторов Европы, Америки и Азии.

С конца 2013 года компания активно расширяет линейку поставок компонентов по направлению коаксиальный кабель, кварцевые генераторы и конденсаторы (керамические, пленочные, электролитические), за счёт заключения дистрибьюторских договоров

Мы предлагаем:

- Конкурентоспособные цены и скидки постоянным клиентам.
- Специальные условия для постоянных клиентов.
- Подбор аналогов.
- Поставку компонентов в любых объемах, удовлетворяющих вашим потребностям.
- Приемлемые сроки поставки, возможна ускоренная поставка.
- Доставку товара в любую точку России и стран СНГ.
- Комплексную поставку.
- Работу по проектам и поставку образцов.
- Формирование склада под заказчика.
- Сертификаты соответствия на поставляемую продукцию (по желанию клиента).
- Тестирование поставляемой продукции.
- Поставку компонентов, требующих военную и космическую приемку.
- Входной контроль качества.
- Наличие сертификата ISO.

В составе нашей компании организован Конструкторский отдел, призванный помогать разработчикам, и инженерам.

Конструкторский отдел помогает осуществить:

- Регистрацию проекта у производителя компонентов.
- Техническую поддержку проекта.
- Защиту от снятия компонента с производства.
- Оценку стоимости проекта по компонентам.
- Изготовление тестовой платы монтаж и пусконаладочные работы.



Тел: +7 (812) 336 43 04 (многоканальный)

Email: org@lifeelectronics.ru