

Applications

- Repeaters
- Mobile Infrastructure
- LTE / WCDMA / CDMA / EDGE
- General Purpose Wireless

Product Features

- 20 – 4000 MHz
- 22 dB Gain At 1900 MHz
- 1.3 dB Noise Figure At 1900 MHz
- +39.5 dBm Output IP3
- 50 Ohm Cascadable Gain Block
- Unconditionally Stable
- High Input Power Capability
- +5 V Single Supply, 125mA Current
- 3 x 3 mm QFN Package

General Description

The TQP3M9019 is a cascadable, high linearity gain block amplifier in a low-cost surface-mount package. At 1.9 GHz, the amplifier typically provides 22 dB gain, +39.5 dBm OIP3, and 1.3 dB Noise Figure while only drawing 125 mA current. The device is housed in a leadfree / green / RoHS-compliant industry-standard 16-pin 3 x 3 mm QFN package.

The TQP3M9019 has the benefit of having high gain across a broad range of frequencies while also providing very low noise. This allows the device to be used in both receiver and transmitter chains for high performance systems. The amplifier is internally matched using a high performance E-pHEMT process and only requires an external RF choke and blocking/bypass capacitors for operation from a single +5 V supply. The internal active bias circuit also enables stable operation over bias and temperature variations.

The TQP3M9019 covers the 0.02–4 GHz frequency band and is targeted for wireless infrastructure or other applications requiring high linearity and/or low noise figure.

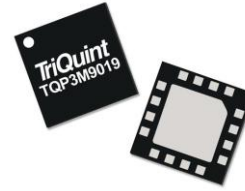

16 Pin 3 x3 mm QFN Package

Functional Block Diagram

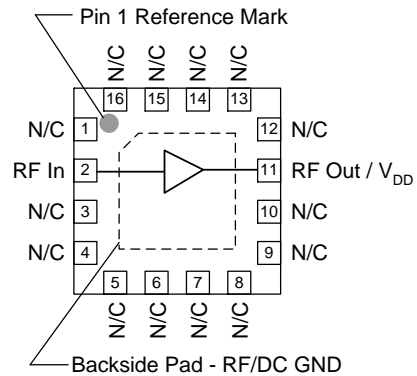

Pin Configuration

Pin No.	Label
2	RF In
11	RF Out / V _{DD}
All Other Pins	N/C
Backside Paddle	RF/DC GND

Ordering Information

Part No.	Description
TQP3M9019	High Linearity LNA Gain Block
TQP3M9019-PCB_IF	50 – 500 MHz Evaluation Board
TQP3M9019-PCB_RF	0.5 – 4 GHz Evaluation Board

Standard T/R size = 2500 pieces on a 7" reel

Absolute Maximum Ratings

Parameter	Rating
Storage Temperature	-65 to 150 °C
RF Input Power, CW, 50Ω, T=25 °C	+23 dBm
Supply Voltage (V _{DD})	+7 V
Reverse Supply Voltage	-0.3 V

Operation of this device outside the parameter ranges given above may cause permanent damage.

Recommended Operating Conditions

Parameter	Min	Typ	Max	Units
Supply Voltage (V _{DD})	+4.75	+5.0	+5.25	V
T _{CASE}	-40		+105	°C
T _{ch} (for >10 ⁶ hours MTTF)			+190	°C

Electrical specifications are measured at specified test conditions. Specifications are not guaranteed over all recommended operating conditions.

Electrical Specifications

Test conditions unless otherwise noted: V_{DD}=+5 V, Temp.=+25 °C, 50 Ω system

Parameter	Conditions	Min	Typ	Max	Units
Operational Frequency Range		20		4000	MHz
Test Frequency			1900		MHz
Gain		20	22	23	dB
Input Return Loss			10		dB
Output Return Loss			13		dB
Output P1dB			+22		dBm
Output IP3	P _{out} =+3 dBm/tone, Δf = 1 MHz	+36	+39.5		dBm
Noise Figure			1.3		dB
Current, I _{DD}			125	150	mA
Thermal Resistance, θ _{Jc}	Module (junction to case)			34	°C/W

TQP3M9019-PCB_IF / RF Evaluation Board

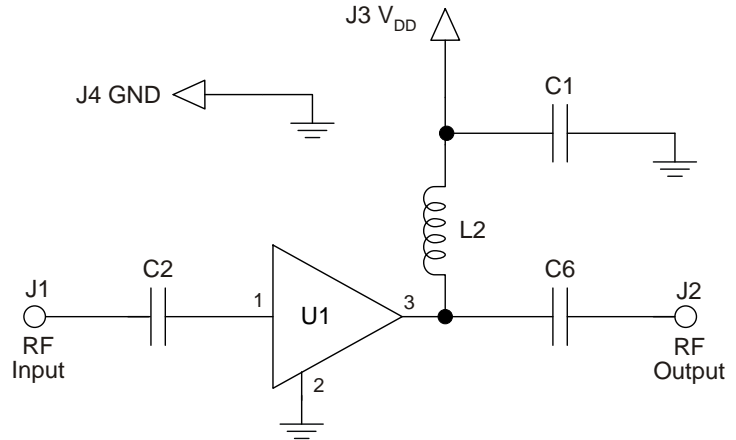
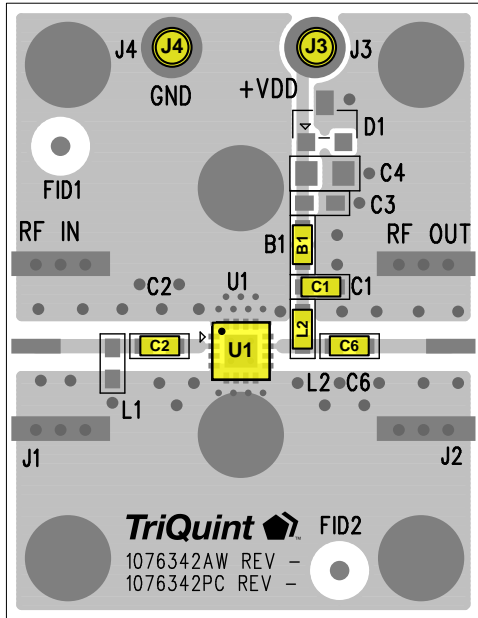

Notes:

1. See Evaluation Board PCB Information section for material and stack-up.
2. Components shown on the silkscreen but not on the schematic are not used.
3. B1 (0 Ω jumper) is not shown on the schematic and may be replaced with copper trace in the target application layout.
4. The recommended component values are dependent upon the frequency of operation.
5. All components are of 0603 size unless otherwise specified.

Bill of Material – TQP3M9019-PCB_IF / RF

Reference Des.	TQP3M9019-PCB_RF 500 MHz – 4000 MHz	TQP3M9019-PCB_IF 50 MHz – 500 MHz
U1	TQP3M9019	TQP3M9019
C2, C6	100 pF	1000 pF
C1	0.01 uF	0.01 uF
L2	68 nH	330 nH
B1	Do Not Place	Do Not Place
L1, D1, C3, C4	0 Ω	0 Ω

Note: Performances can be optimized at frequency of interest by using recommended component values shown in the table below. Inductors are wirewound Coilcraft.

Reference Designation	Frequency (MHz)					
	50	200	500	2000	2500	3500
C2, C6	0.01 uF	1000 pF	100 pF	22 pF	22 pF	22 pF
L2	470 nH	220 nH	82 nH	22 nH	18 nH	15 nH

Typical Performance – TQP3M9019-PCB_RF

Test conditions unless otherwise noted: $V_{DD}=+5\text{ V}$, $I_{DD}=125\text{ mA}$, Temp. $=+25\text{ }^{\circ}\text{C}$, $50\ \Omega$ system

Parameter	Typical Value						Units
Frequency	500	900	1900	2700	3500	4000	MHz
Gain	25.6	24.6	22	20.5	19	18.3	dB
Input Return Loss	11	10.5	10	11.5	8	6	dB
Output Return Loss	10.5	12	13	9	10	11	dB
Output P1dB	+22.4	+22.3	+22	+21.7	+21.4	+20.8	dBm
OIP3 ⁽¹⁾	+41.8	+40.6	+40.6	+38.5	+38.8	+37.9	dBm
Noise figure ⁽²⁾	0.9	0.9	1.3	1.7	2.1	2.4	dB

Notes:

- OIP3 measured with two tones at an output power of +4 dBm / tone separated by 1 MHz.
- Noise figure data listed in the table above includes PCB losses. ~0.1dB at 2 GHz.

Performance Plots – TQP3M9019-PCB_RF

Test conditions unless otherwise noted: $V_{DD}=+5\text{ V}$, $I_{DD}=125\text{ mA}$, Temp. $=+25\text{ }^{\circ}\text{C}$, $50\ \Omega$ system

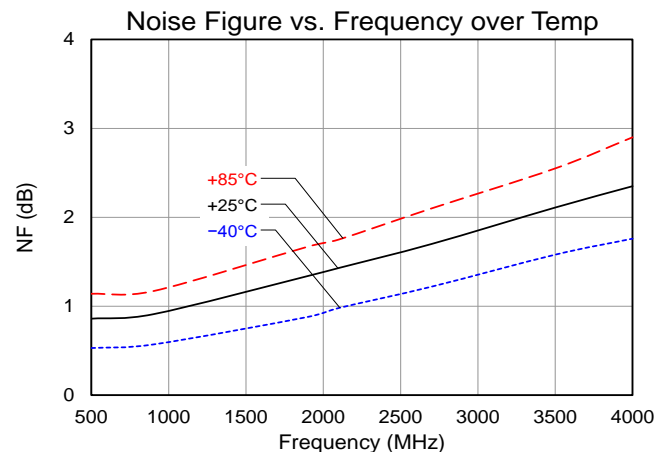
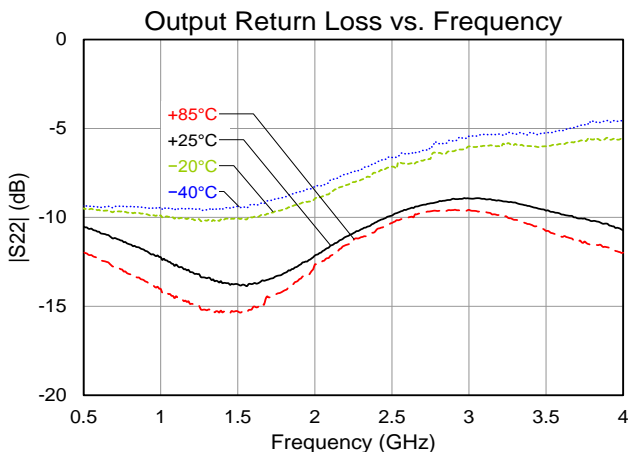
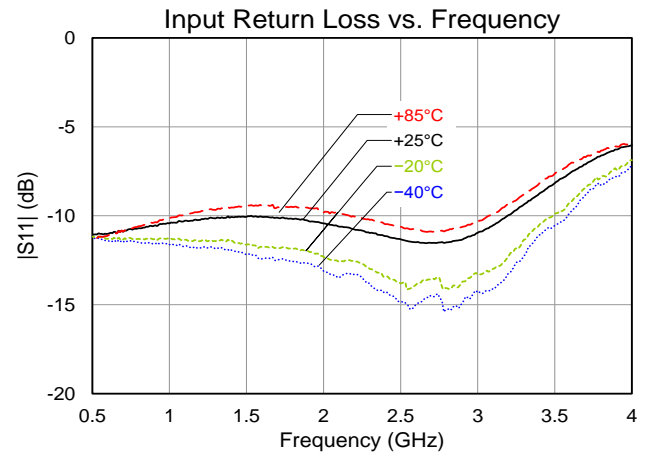
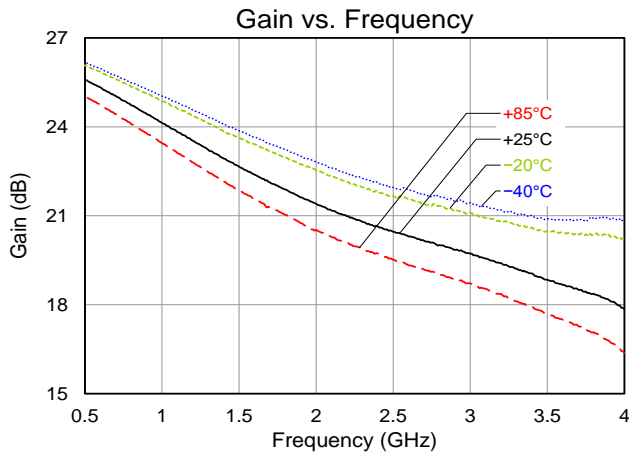

Performance Plots – TQP3M9019-PCB_RF

Test conditions unless otherwise noted: $V_{DD}=+5\text{ V}$, $I_{DD}=125\text{ mA}$, Temp.=+25 °C, 50 Ω system

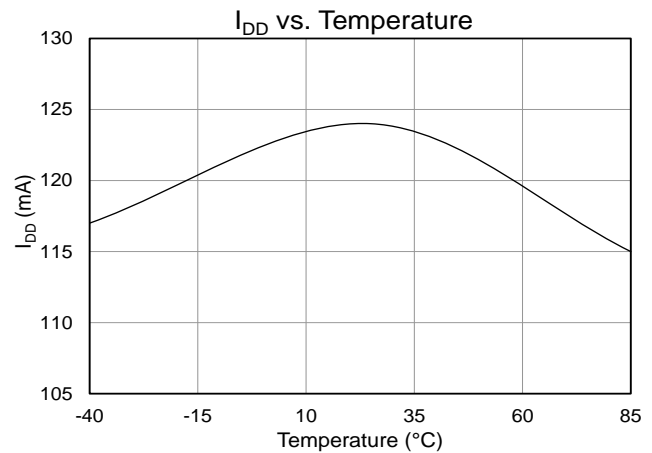
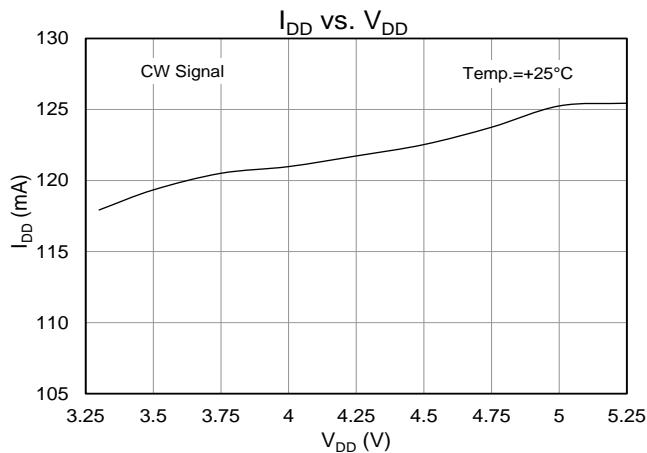
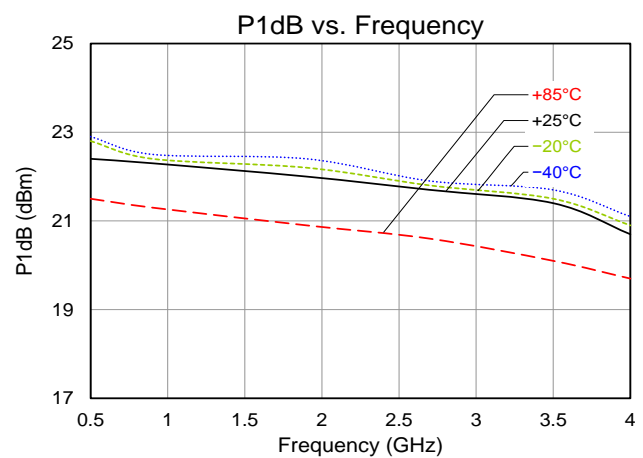
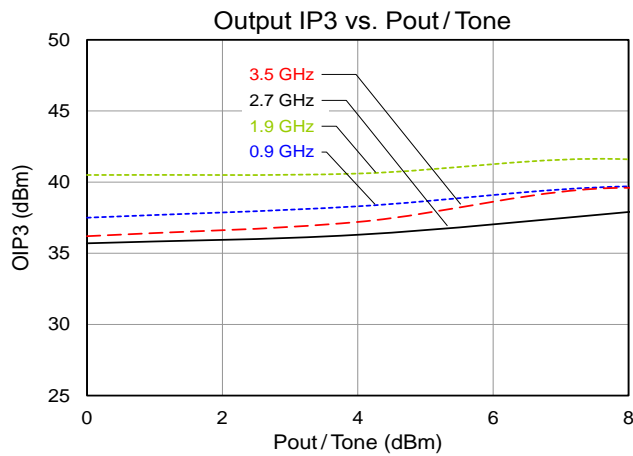
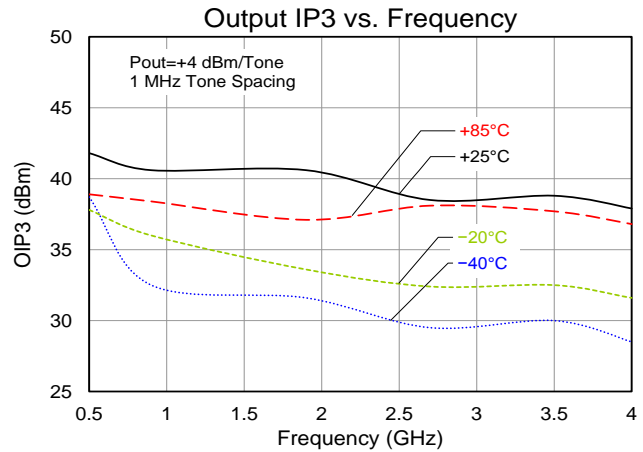
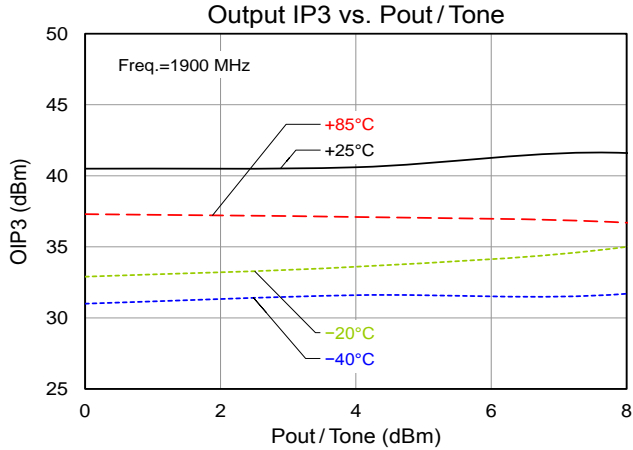

Typical Performance – TQP3M9019-PCB_IF

Test conditions unless otherwise noted: $V_{DD}=+5V$, $I_{DD}=125\text{ mA typ.}$, Temp= $+25^{\circ}\text{C}$

Parameter	Conditions	Typical Values				Units
Frequency		70	100	200	500	MHz
Gain		27	26.8	26.4	25.8	dB
Input Return Loss		12	13	13	13	dB
Output Return Loss		11	11	12	13	dB
Output P1dB		+21.6	+21.9	+21.9	+22.2	dBm
OIP3	$P_{out} = +3\text{ dBm/tone}$, $\Delta f=1\text{ MHz}$	+37.6	+38.8	+39	+41.4	dBm
Noise figure		1.4	1.3	0.9	0.9	dB

Performance Plots – TQP3M9019-PCB_IF

Test conditions unless otherwise noted: $V_{DD}=+5V$, Temp.= $+25^{\circ}\text{C}$

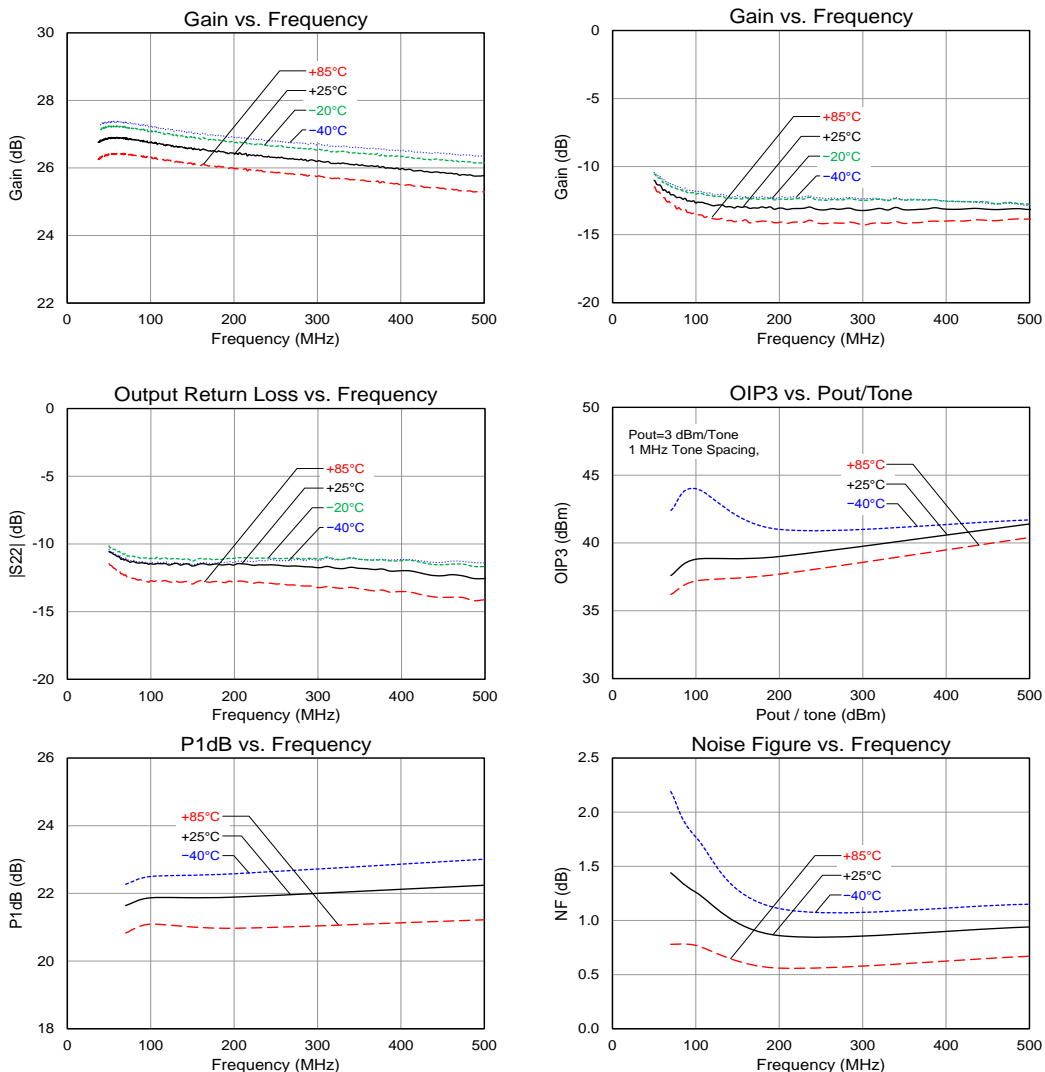

Pin Configuration and Description

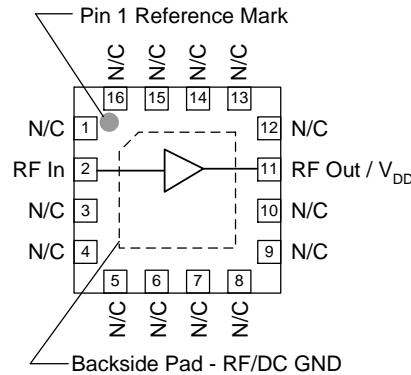

Pin No.	Label	Description
2	RF In	RF input matched to 50 ohms. External DC Block is required.
11	RF Out / V _{DD}	RF output matched to 50 ohms. Bias voltage and external DC Block required.
All other pins	N/C	No internal connection. Provide grounded PCB land pads for optimal isolation and mounting integrity.
Backside Pad	RF/DC GND	RF/DC ground. Use recommended via pattern to minimize inductance and thermal resistance. See PCB Mounting Pattern.

Evaluation Board PCB Information

TriQuint PCB 1076342 Material and Stack-up

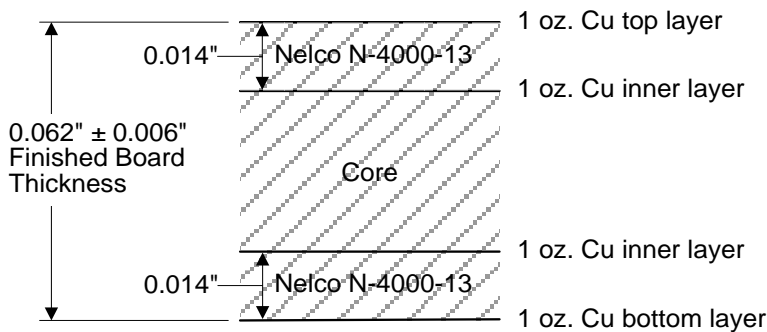

50 ohm line dimensions: width = 0.029", spacing = 0.035"

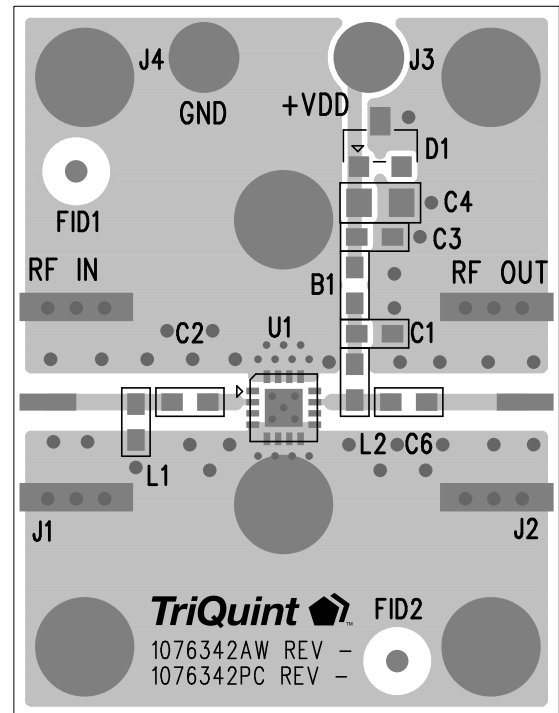

Package Marking and Dimensions

Package Marking: Part number – 9019
 Year/week/country code – YYWW
 Lot code – aXXXX

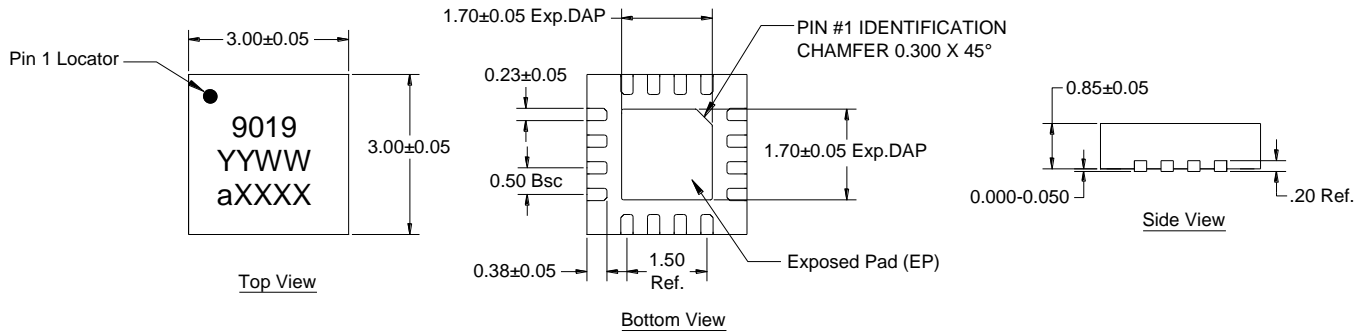

Notes:

1. All dimensions are in millimeters. Angles are in degrees.
2. Dimension and tolerance formats conform to ASME Y14.4M-1994.
3. The terminal #1 identifier and terminal numbering conform to JESD 95-1 SPP-012.

PCB Mounting Pattern

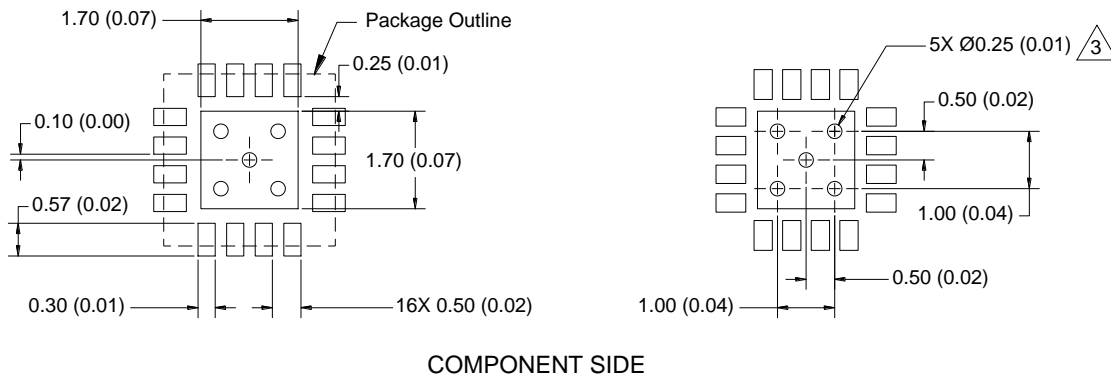

Notes:

1. All dimensions are in millimeters (inches). Angles are in degrees.
2. Use 1 oz. copper minimum for top and bottom layer metal.
3. Ground/thermal vias are required for the proper operation of this device. We recommend a 0.35mm (#80/.0135") diameter bit for drilling via holes and a final plated thru diameter of 0.25mm (0.10").
4. Ensure good package backside exposed pad (EP) solder attach for best electrical and thermal performance.

Product Compliance Information

ESD Sensitivity Ratings



Caution! ESD-Sensitive Device

ESD Rating: Class 1A
Value: ≥ 250 V to < 500 V
Test: Human Body Model (HBM)
Standard: ESDA / JEDEC Standard JS-001-2012

ESD Rating: Class C3
Value: ≥ 1000 V
Test: Charged Device Model (CDM)
Standard: JEDEC Standard JESD22-C101F

MSL Rating

MSL Rating: Level 1
Test: 260 °C convection reflow
Standard: JEDEC Standard IPC/JEDEC J-STD-020

Solderability

Compatible with both lead-free (260 °C max. reflow temperature) and tin/lead (245 °C max. reflow temperature) soldering processes.

Contact plating: Annealed Matte Tin

RoHS Compliance

This part is compliant with EU 2002/95/EC RoHS directive (Restrictions on the Use of Certain Hazardous Substances in Electrical and Electronic Equipment).

This product also has the following attributes:

- Lead Free
- Halogen Free (Chlorine, Bromine)
- Antimony Free
- TBBP-A (C₁₅H₁₂Br₄O₂) Free
- PFOS Free
- SVHC Free

Contact Information

For the latest specifications, additional product information, worldwide sales and distribution locations:

Web: www.triquint.com **Tel:** 877-800-8584
Email: customer.support@qorvo.com

For information about the merger of RFMD and TriQuint as Qorvo:

Web: www.qorvo.com

For technical questions and application information:

Email: sjcappliations.engineering@qorvo.com

Important Notice

The information contained herein is believed to be reliable. TriQuint makes no warranties regarding the information contained herein. TriQuint assumes no responsibility or liability whatsoever for any of the information contained herein. TriQuint assumes no responsibility or liability whatsoever for the use of the information contained herein. The information contained herein is provided "AS IS, WHERE IS" and with all faults, and the entire risk associated with such information is entirely with the user. All information contained herein is subject to change without notice. Customers should obtain and verify the latest relevant information before placing orders for TriQuint products. The information contained herein or any use of such information does not grant, explicitly or implicitly, to any party any patent rights, licenses, or any other intellectual property rights, whether with regard to such information itself or anything described by such information.

TriQuint products are not warranted or authorized for use as critical components in medical, life-saving, or life-sustaining applications, or other applications where a failure would reasonably be expected to cause severe personal injury or death.

Компания «Life Electronics» занимается поставками электронных компонентов импортного и отечественного производства от производителей и со складов крупных дистрибьюторов Европы, Америки и Азии.

С конца 2013 года компания активно расширяет линейку поставок компонентов по направлению коаксиальный кабель, кварцевые генераторы и конденсаторы (керамические, пленочные, электролитические), за счёт заключения дистрибьюторских договоров

Мы предлагаем:

- Конкурентоспособные цены и скидки постоянным клиентам.
- Специальные условия для постоянных клиентов.
- Подбор аналогов.
- Поставку компонентов в любых объемах, удовлетворяющих вашим потребностям.
- Приемлемые сроки поставки, возможна ускоренная поставка.
- Доставку товара в любую точку России и стран СНГ.
- Комплексную поставку.
- Работу по проектам и поставку образцов.
- Формирование склада под заказчика.
- Сертификаты соответствия на поставляемую продукцию (по желанию клиента).
- Тестирование поставляемой продукции.
- Поставку компонентов, требующих военную и космическую приемку.
- Входной контроль качества.
- Наличие сертификата ISO.

В составе нашей компании организован Конструкторский отдел, призванный помогать разработчикам, и инженерам.

Конструкторский отдел помогает осуществить:

- Регистрацию проекта у производителя компонентов.
- Техническую поддержку проекта.
- Защиту от снятия компонента с производства.
- Оценку стоимости проекта по компонентам.
- Изготовление тестовой платы монтаж и пусконаладочные работы.



Тел: +7 (812) 336 43 04 (многоканальный)
Email: org@lifeelectronics.ru