

1. SCOPE

1.1 Scope. This drawing documents the general requirements of a high performance 3-Axis, ±200 g Digital MEMS Accelerometer microcircuit, with an operating temperature range of -55°C to +105°C.

1.2 Vendor Item Drawing Administrative Control Number. The manufacturer's PIN is the item of identification. The vendor item drawing establishes an administrative control number for identifying the item on the engineering documentation:

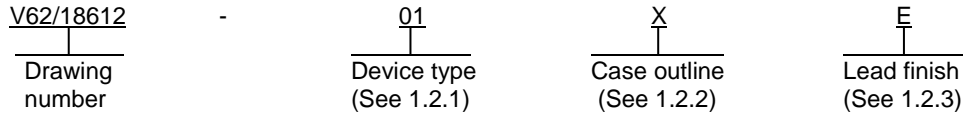

1.2.1 Device type(s).

<u>Device type</u>	<u>Generic</u>	<u>Circuit function</u>
01	ADXL375 –EP	3-Axis, ±200 g Digital MEMS Accelerometer

1.2.2 Case outline(s). The case outlines are as specified herein.

<u>Outline letter</u>	<u>Number of pins</u>	<u>Package style</u>
X	14	Land Grid Array (LGA) Package

1.2.3 Lead finishes. The lead finishes are as specified below or other lead finishes as provided by the device manufacturer:

<u>Finish designator</u>	<u>Material</u>
A	Hot solder dip
B	Tin-lead plate
C	Gold plate
D	Palladium
E	Gold flash palladium
F	Tin-lead alloy (BGA/CGA)
Z	Other

DLA LAND AND MARITIME COLUMBUS, OHIO	SIZE A	CODE IDENT NO. 16236	DWG NO. V62/18612
		REV	PAGE 2

1.3 Absolute maximum ratings. 1/

Acceleration, Any Axis :	
Unpowered	10000 g
Powered	10000 g
V _S	-0.3 V to 3.9 V
V _{DD I/O}	-0.3 V to 3.9 V
Digital Pins	-0.3 V to V _{DD I/O} + 0.3 V or 3.9 V whichever is less
Output Short-Circuit Duration (Any Pin to Ground)	Indefinite
Temperature Range:	
Powered	-55°C to 105°C
Storage	-65°C to 150°C

1.4 Thermal characteristics.

Thermal resistance

Case outline	θ_{JA}	θ_{JC}	Unit
Case X 2/	150	85	°C/W

2. APPLICABLE DOCUMENTS

JEDEC – SOLID STATE TECHNOLOGY ASSOCIATION (JEDEC)

JESD51 – Methodology for the Thermal Measurement of Component Packages (Single Semiconductor Device).

(Applications for copies should be addressed to the Electronic Industries Alliance, 3103 North 10th Street, Suite 240–S, Arlington, VA 22201-2107 or online at <https://www.jedec.org>)

- 1/ Stresses beyond those listed under “absolute maximum ratings” may cause permanent damage to the device. These are stress ratings only, and functional operation of the device at these or any other conditions beyond those indicated under “recommended operating conditions” is not implied. Exposure to absolute maximum rated conditions for extended periods may affect device reliability.
- 2/ Thermal impedance simulated values are based on JEDEC 2S2P thermal test board. See JEDEC JESD-51

DLA LAND AND MARITIME COLUMBUS, OHIO	SIZE A	CODE IDENT NO. 16236	DWG NO. V62/18612
		REV	PAGE 3

3. REQUIREMENTS

3.1 Marking. Parts shall be permanently and legibly marked with the manufacturer's part number as shown in 6.3 herein and as follows:

- A. Manufacturer's name, CAGE code, or logo
- B. Pin 1 identifier
- C. ESDS identification (optional)

3.2 Unit container. The unit container shall be marked with the manufacturer's part number and with items A and C (if applicable) above.

3.3 Electrical characteristics. The maximum and recommended operating conditions and electrical performance characteristics are as specified in 1.3, 1.4, and table I herein.

3.4 Design, construction, and physical dimension. The design, construction, and physical dimensions are as specified herein.

3.5 Diagrams.

- 3.5.1 Case outline. The case outline shall be as shown in 1.2.2 and figure 1.
- 3.5.2 Terminal connections. The terminal connections shall be as shown in figure 2.
- 3.5.3 Terminal function. The terminal function shall be as shown in figure 3.
- 3.5.4 Functional block diagram. The functional block diagram shall be as shown in figure 4.

DLA LAND AND MARITIME COLUMBUS, OHIO	SIZE A	CODE IDENT NO. 16236	DWG NO. V62/18612
		REV	PAGE 4

TABLE I. Electrical performance characteristics. 1/

Test	Test conditions 2/	Limits			Unit
		Min	Typ 3/	Max	
SENSOR INPUT (Each Axis)					
Measurement Range 4/		±180	±200		g
Nonlinearity	Percentage of full scale		±0.25		%
Cross-Axis Sensitivity 5/			±2.5		%
SENSITIVITY (Each Axis)					
Sensitivity at X _{OUT} , Y _{OUT} , Z _{OUT} 4/ 6/	ODR ≤ 800 Hz	18.4	20.5	22.6	LSB/g
Scale Factor at X _{OUT} , Y _{OUT} , Z _{OUT} 4/ 6/	ODR ≤ 800 Hz	44	49	54	mg/LSB
Sensitivity Change Due to Temperature			±0.02		%/°C
0 g OFFSET (Each Axis)					
0 g Output for X _{OUT} , Y _{OUT} , Z _{OUT}		-6000	±400	+6000	mg
0 g Offset vs. Temperature			±10		mg/°C
NOISE					
Noise	X-, y-, and z-axes		5		mg/√Hz
OUTPUT DATA RATE AND BANDWIDTH (User selectable) 7/					
Output Data Rate (ODR) 6/ 8/		0.1		3200	Hz
SELF-TEST					
Output Change in Z-Axis			6.4		g
POWER SUPPLY					
Operating Voltage Range (V _s)		2.0	2.5	3.6	V
Interface Voltage Range (V _{DD I/O})		1.7	1.8	V _s	V
Supply Current					
Measurement Mode	ODR ≥ 100 Hz ODR ≤ 3 Hz		145 35		μA μA
Standby Mode			0.1		μA
Turn-On and Wake-Up Time 10/	ODR = 3200 Hz		1.4		ms
TEMPERATURE					
Operating Temperature Range		-55		+105	°C
WEIGHT					
Device Weight			30		mg

See footnote at end of table.

DLA LAND AND MARITIME COLUMBUS, OHIO	SIZE A	CODE IDENT NO. 16236	DWG NO. V62/18612
		REV	PAGE 5

TABLE I. Electrical performance characteristics - Continued. 1/

- 1/ Testing and other quality control techniques are used to the extent deemed necessary to assure product performance over the specified temperature range. Product may not necessarily be tested across the full temperature range and all parameters may not necessarily be tested. In the absence of specific parametric testing, product performance is assured by characterization and/or design.
- 2/ $T_A = 25^\circ\text{C}$, $V_S = 2.5\text{ V}$, $V_{DD\ I/O} = 2.5\text{ V}$, acceleration = 0 g, $C_S = 10\ \mu\text{F}$ tantalum, $C_{I/O} = 0.1\ \mu\text{F}$, and output data rate (ODR) = 800 Hz, unless otherwise noted.
- 3/ Typical specifications are for at least 68% of the population of devices and are based on the worst case of mean $\pm 1\ \sigma$ distribution, except for sensitivity, which represents the target value.
- 4/ Minimum and maximum specifications represent the worst case of mean $\pm 3\ \sigma$ distribution and are not guaranteed in production.
- 5/ Cross axis sensitivity is defined as coupling between any two axes.
- 6/ The output format for the 1600 Hz and 3200 Hz output data rates is different from the output format for the other output data rates. For more information, see manufacturer data sheet.
- 7/ Bandwidth is the -3 dB frequency and is half the output data rate: bandwidth = ODR/2.
- 8/ Output data rates < 6.25 Hz exhibit additional offset shift with increased temperature.
- 9/ Self test change is defined as the output (g) when the SELF_TEST bit = 1 (DATA_FORMAT register, Address 0x31) minus the output (g) when the SELF_TEST bit = 0. Due to device filtering, the output reaches its final value after $4 \times \tau$ when enabling or disabling self test, where $\tau = 1/(\text{data rate})$. For the self test to operate correctly, the part must be in normal power operation (LOW_POWER bit = 0 in the BW_RATE register, Address 0x2C).
- 10/ Turn on and wake-up times are determined by the user defined bandwidth. At a 100 Hz data rate, the turn on and wake-up times are each approximately 11.1 ms. For other data rates, the turn on and wake-up times are each approximately $\tau + 1.1\text{ ms}$, where $\tau = 1/(\text{data rate})$.

DLA LAND AND MARITIME COLUMBUS, OHIO	SIZE A	CODE IDENT NO. 16236	DWG NO. V62/18612
		REV	PAGE 6

Case X

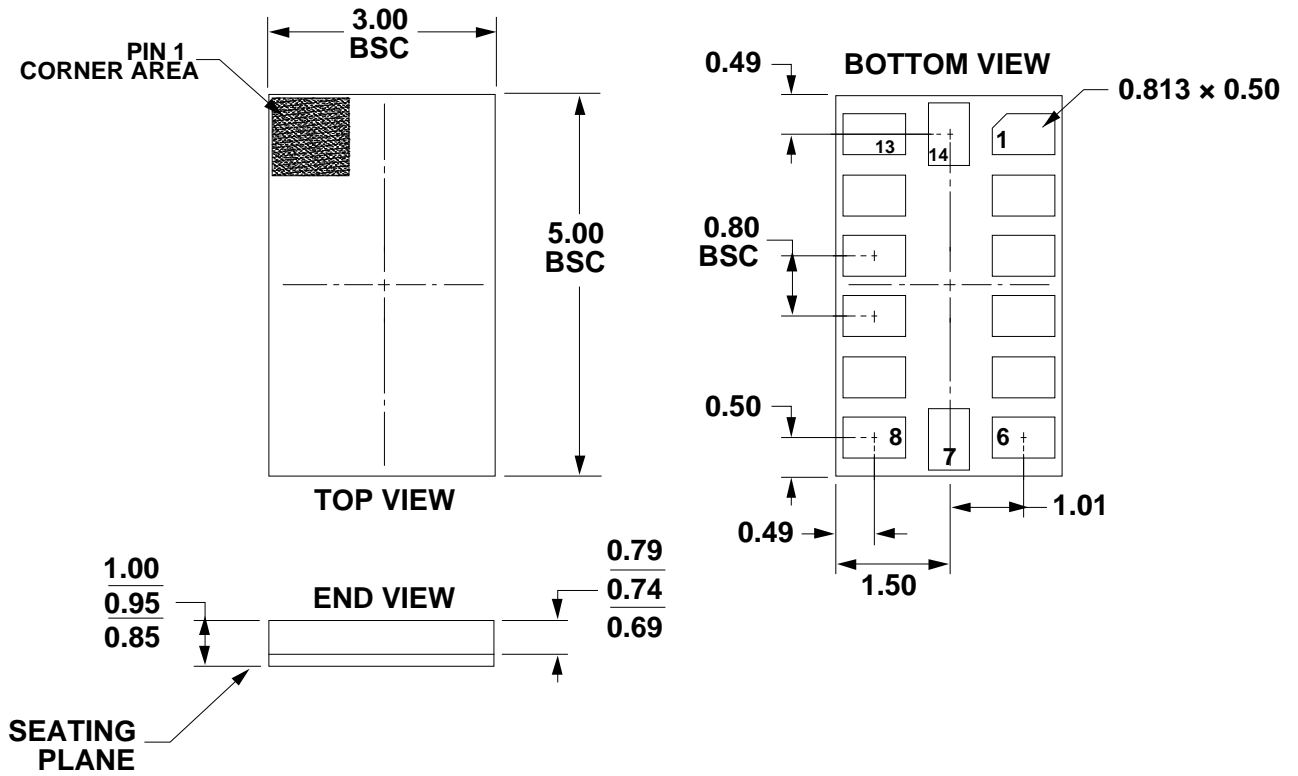

NOTES:

1. All linear dimensions are in millimeters.

FIGURE 1. Case outline.

<p align="center">DLA LAND AND MARITIME COLUMBUS, OHIO</p>	<p align="center">SIZE A</p>	<p align="center">CODE IDENT NO. 16236</p>	<p align="center">DWG NO. V62/18612</p>
		<p align="center">REV</p>	<p align="center">PAGE 7</p>

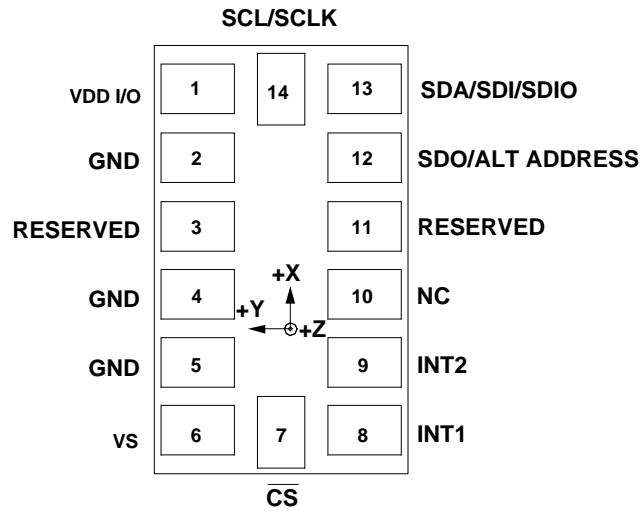

FIGURE 2. Terminal connections.

Pin No.	Mnemonic	Description
1	V _{DD I/O}	Digital Interface Supply Voltage.
2	GND	Ground. This pin must be connected to ground.
3	RESERVED	Reserved. This pin must be connected to V _s or left open.
4	GND	Ground. This pin must be connected to ground.
5	GND	Ground. This pin must be connected to ground.
6	V _s	Supply Voltage.
7	\overline{CS}	Chip Select.
8	INT1	Interrupt 1 Output.
9	INT2	Interrupt 2 Output.
10	NC	Not Internally Connected.
11	RESERVED	Reserved. This pin must be connected to ground or left open.
12	SDO/ALT ADDRESS	SPI 4-Wire Serial Data Output (SDO)/I ² C Alternate Address Select (ALT ADDRESS).
13	SDA/SDI/SDIO	I ² C Serial Data (SDA)/SPI 4-Wire Serial Data Input (SDI)/SPI 3-Wire Serial Data Input and Output (SDIO).
14	SCL/SCLK	I ² C Serial Communications Clock (SCL)/SPI Serial Communications Clock (SCLK).

FIGURE 3. Terminal function.

DLA LAND AND MARITIME COLUMBUS, OHIO	SIZE A	CODE IDENT NO. 16236	DWG NO. V62/18612
		REV	PAGE 8

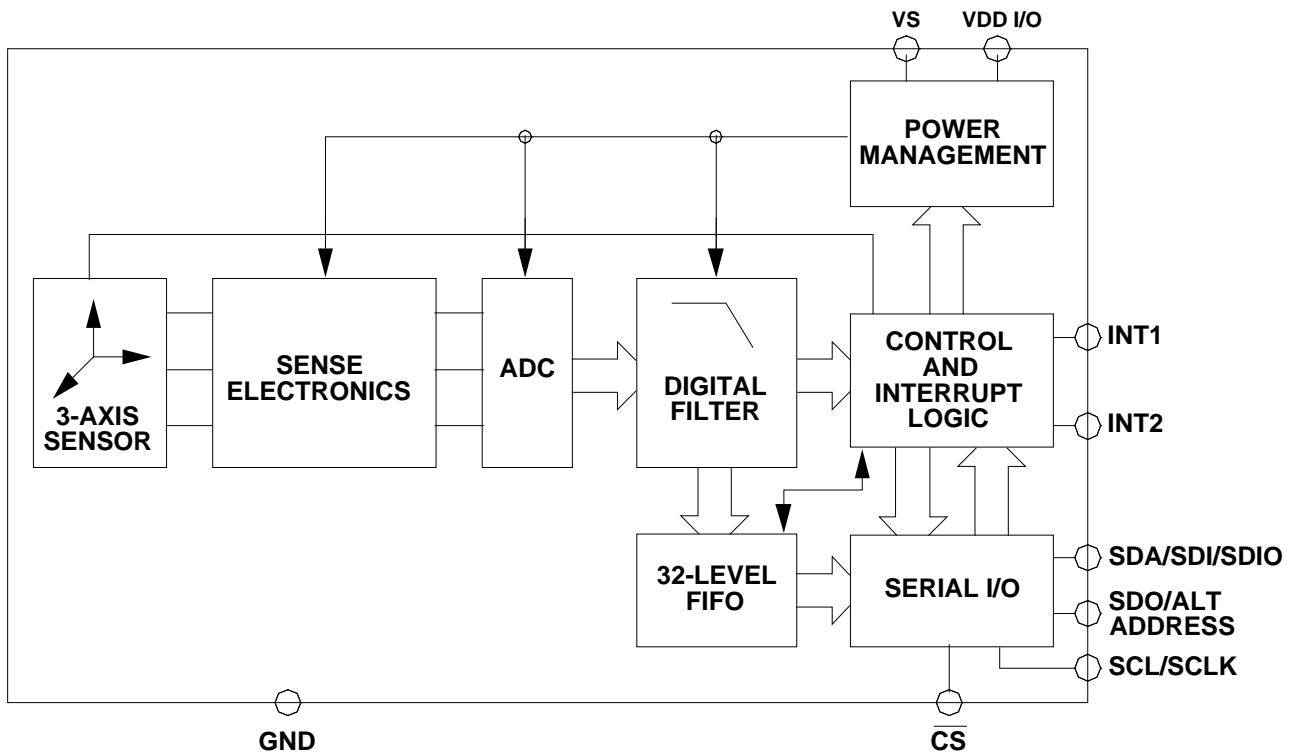

FIGURE 4. Functional block diagram.

<p>DLA LAND AND MARITIME COLUMBUS, OHIO</p>	<p>SIZE A</p>	<p>CODE IDENT NO. 16236</p>	<p>DWG NO. V62/18612</p>
		<p>REV</p>	<p>PAGE 9</p>

4. VERIFICATION

4.1 Product assurance requirements. The manufacturer is responsible for performing all inspection and test requirements as indicated in their internal documentation. Such procedures should include proper handling of electrostatic sensitive devices, classification, packaging, and labeling of moisture sensitive devices, as applicable.

5. PREPARATION FOR DELIVERY

5.1 Packaging. Preservation, packaging, labeling, and marking shall be in accordance with the manufacturer's standard commercial practices for electrostatic discharge sensitive devices.

6. NOTES

6.1 ESDS. Devices are electrostatic discharge sensitive and are classified as ESDS class 1 minimum.

6.2 Configuration control. The data contained herein is based on the salient characteristics of the device manufacturer's data book. The device manufacturer reserves the right to make changes without notice. This drawing will be modified as changes are provided.

6.3 Suggested source(s) of supply. Identification of the suggested source(s) of supply herein is not to be construed as a guarantee of present or continued availability as a source of supply for the item. DLA Land and Maritime maintains an online database of all current sources of supply at <https://landandmaritimeapps.dla.mil/programs/smcr/default.aspx>

Vendor item drawing administrative control number <u>1/</u>	Device manufacturer CAGE code	Order Quantity	Vendor part number
V62/18612-01XE	24355	Tray = 490	ADXL375SCCZ-EP
		RL7 quantity = 1500	ADXL375SCCZ-EP -RL7

1/ The vendor item drawing establishes an administrative control number for identifying the item on the engineering documentation.

CAGE code

24355

Source of supply

Analog Devices
 1 Technology Way
 P.O. Box 9106
 Norwood, MA 02062-9106

DLA LAND AND MARITIME COLUMBUS, OHIO	SIZE A	CODE IDENT NO. 16236	DWG NO. V62/18612
		REV	PAGE 10

Компания «Life Electronics» занимается поставками электронных компонентов импортного и отечественного производства от производителей и со складов крупных дистрибьюторов Европы, Америки и Азии.

С конца 2013 года компания активно расширяет линейку поставок компонентов по направлению коаксиальный кабель, кварцевые генераторы и конденсаторы (керамические, пленочные, электролитические), за счёт заключения дистрибьюторских договоров

Мы предлагаем:

- Конкурентоспособные цены и скидки постоянным клиентам.
- Специальные условия для постоянных клиентов.
- Подбор аналогов.
- Поставку компонентов в любых объемах, удовлетворяющих вашим потребностям.
- Приемлемые сроки поставки, возможна ускоренная поставка.
- Доставку товара в любую точку России и стран СНГ.
- Комплексную поставку.
- Работу по проектам и поставку образцов.
- Формирование склада под заказчика.
- Сертификаты соответствия на поставляемую продукцию (по желанию клиента).
- Тестирование поставляемой продукции.
- Поставку компонентов, требующих военную и космическую приемку.
- Входной контроль качества.
- Наличие сертификата ISO.

В составе нашей компании организован Конструкторский отдел, призванный помогать разработчикам, и инженерам.

Конструкторский отдел помогает осуществить:

- Регистрацию проекта у производителя компонентов.
- Техническую поддержку проекта.
- Защиту от снятия компонента с производства.
- Оценку стоимости проекта по компонентам.
- Изготовление тестовой платы монтаж и пусконаладочные работы.



Тел: +7 (812) 336 43 04 (многоканальный)

Email: org@lifeelectronics.ru