

# Infineon<sup>®</sup> Power LED Driver

## TLD5095EL

Multitopology High Power LED DC/DC  
Controller IC

Datasheet

Rev. 1.4, 2014-03-10

Automotive Power

## Table of Contents

|           |  |           |
|-----------|--|-----------|
| <b>1</b>  | <b>Overview</b> .....                            | <b>3</b>  |
| <b>2</b>  | <b>Block Diagram</b> .....                       | <b>4</b>  |
| <b>3</b>  | <b>Pin Configuration</b> .....                   | <b>5</b>  |
| 3.1       | Pin Assignment .....                             | 5         |
| 3.2       | Pin Definitions and Functions .....              | 5         |
| <b>4</b>  | <b>General Product Characteristics</b> .....     | <b>7</b>  |
| 4.1       | Absolute Maximum Ratings .....                   | 7         |
| 4.2       | Functional Range .....                           | 8         |
| 4.3       | Thermal Resistance .....                         | 8         |
| <b>5</b>  | <b>Regulator</b> .....                           | <b>9</b>  |
| 5.1       | Description .....                                | 9         |
| 5.2       | Electrical Characteristics .....                 | 10        |
| <b>6</b>  | <b>Oscillator and Synchronization</b> .....      | <b>11</b> |
| 6.1       | Description .....                                | 11        |
| 6.2       | Electrical Characteristics .....                 | 12        |
| <b>7</b>  | <b>Enable and Dimming Function</b> .....         | <b>14</b> |
| 7.1       | Description .....                                | 14        |
| 7.2       | Electrical Characteristics .....                 | 15        |
| <b>8</b>  | <b>Linear Regulator</b> .....                    | <b>17</b> |
| 8.1       | Description .....                                | 17        |
| 8.2       | Electrical Characteristics .....                 | 18        |
| <b>9</b>  | <b>Protection and Diagnostic Functions</b> ..... | <b>19</b> |
| 9.1       | Description .....                                | 19        |
| 9.2       | Electrical Characteristics .....                 | 23        |
| <b>10</b> | <b>Application Information</b> .....             | <b>24</b> |
| 10.1      | Further Application Information .....            | 30        |
| <b>11</b> | <b>Revision History</b> .....                    | <b>31</b> |
| <b>12</b> | <b>Package Outlines</b> .....                    | <b>32</b> |

**TLD5095EL**

# 1 Overview

**Features**

- Wide Input Voltage Range from 4.75 V to 45 V
- Constant Current or Constant Voltage Regulation
- Drives LEDs in Boost, Buck, Buck-Boost, SEPIC and Flyback Topology
- Very Low Shutdown Current:  $I_Q < 10 \mu\text{A}$
- Flexible Switching Frequency Range, 100 kHz to 500 kHz
- Synchronization with external clock source
- Output Open Circuit Diagnostic Output
- PWM Dimming
- Internal Soft Start
- 300mV High Side Current Sense to ensure highest flexibility and LED current accuracy
- Internal 5 V Low Drop Out Voltage Regulator
- Wide LED current range via simple adaptation of external components
- Available in a small thermally enhanced PG-SSOP-14 package
- Output Overvoltage Protection
- Over Temperature Shutdown
- Automotive AEC Qualified
- Green Product (RoHS) Compliant

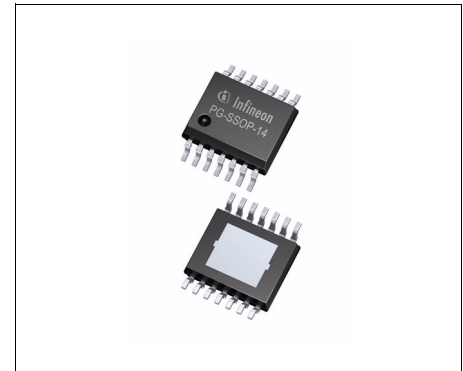
**PG-SSOP-14**
**Description**

The TLD5095EL is a smart multitopology LED controller with built in protection and diagnostic features. The main function of this device is to regulate a constant LED current. The constant current regulation is especially beneficial for LED color accuracy and longer lifetime. The controller concept of the TLD5095EL allows a multi-purpose usage such as Boost, Buck, Buck-Boost, SEPIC and Flyback configuration with various load current levels by simply adjusting the external components. The TLD5095EL has a PWM output for dimming a LED load. The diagnostics are communicated on a status output (pin ST) to indicate a fault condition such as an LED open circuit. The switching frequency is adjustable in the range of 100 kHz to 500 kHz and can be synchronized to an external clock source. The TLD5095EL features an enable function reducing the shut-down current consumption to  $<10 \mu\text{A}$ . The current mode regulation scheme of this device provides a stable regulation loop maintained by small external compensation components. The integrated soft-start feature limits the current peak as well as voltage overshoot at start-up. This IC is suited for use in the harsh automotive environments and provides protection functions such as output overvoltage protection and overtemperature shutdown.

**Applications**

- Automotive Exterior and Interior Lighting

| Type      | Package    | Marking |
|-----------|------------|---------|
| TLD5095EL | PG-SSOP-14 | TLD5095 |

## 2 Block Diagram

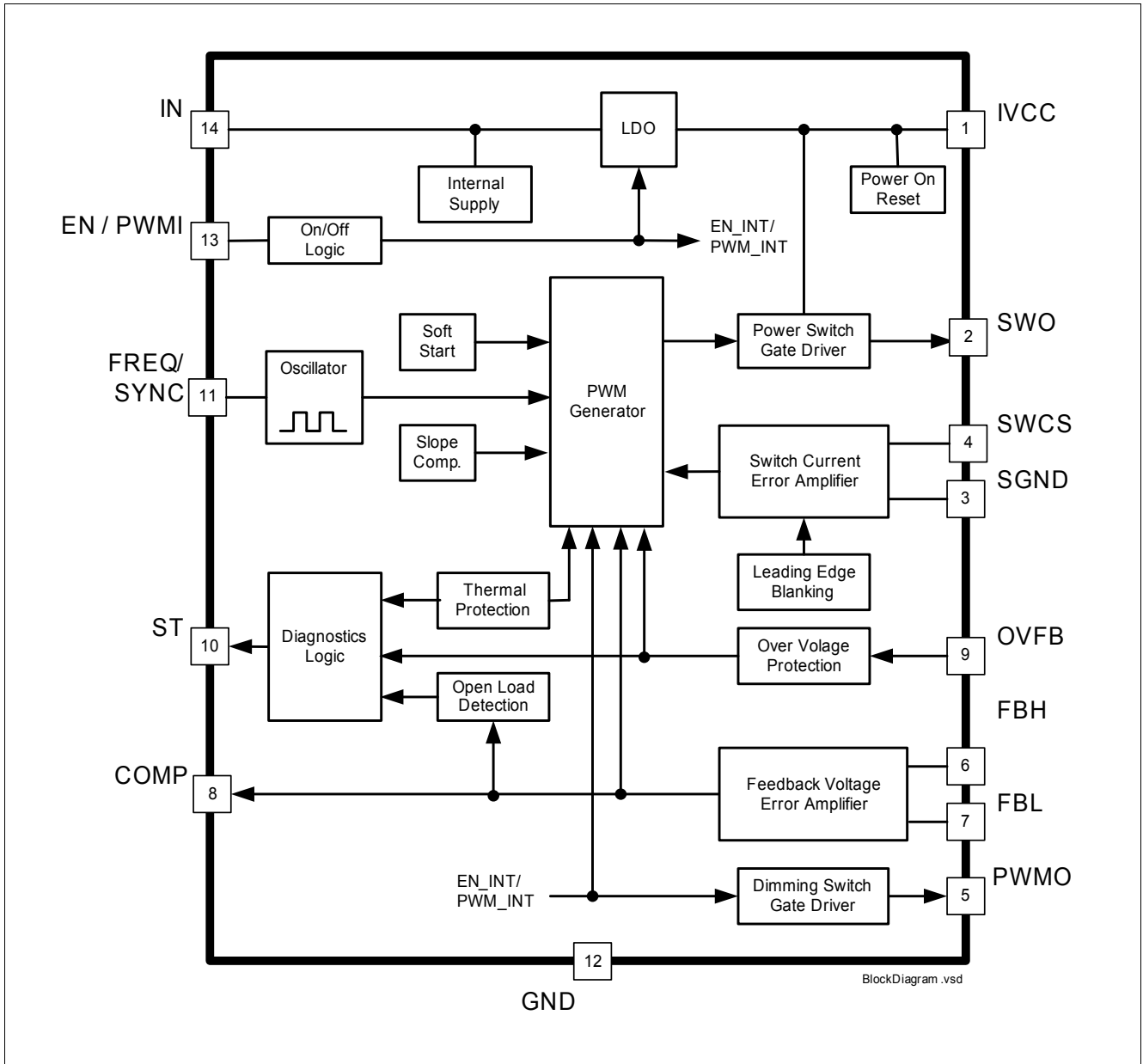

Figure 1 Block Diagram

### 3 Pin Configuration

#### 3.1 Pin Assignment

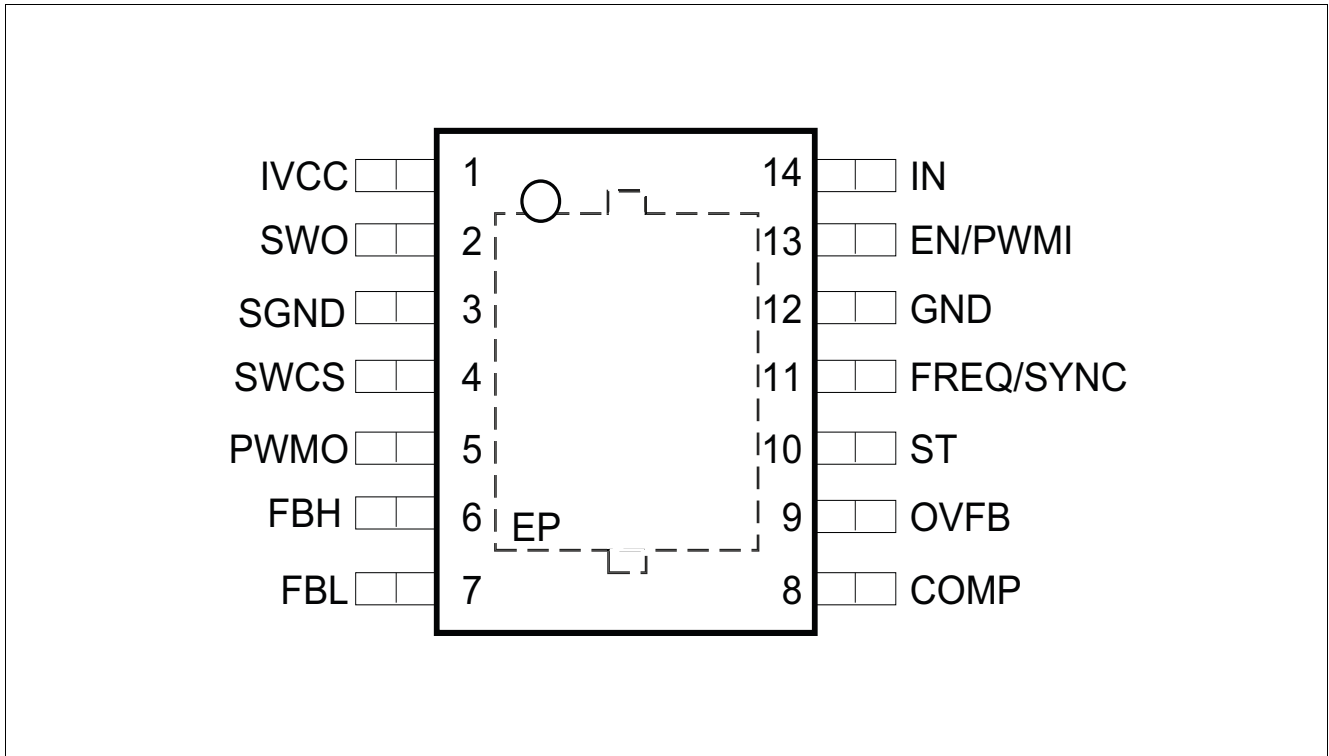

Figure 2 Pin Configuration

#### 3.2 Pin Definitions and Functions

| Pin | Symbol | Function   |
|-----|--------|--|
| 1   | IVCC   | <b>Internal LDO Output;</b><br>Used for internal biasing and gate drive. Bypass with external capacitor. Pin must not left open. |
| 2   | SWO    | <b>Switch Output;</b><br>Connect to gate of external switching MOSFET  |
| 3   | SGND   | <b>Current Sense Ground;</b><br>Ground return for current sense switch   |
| 4   | SWCS   | <b>Current Sense Input;</b><br>Detects the peak current through switch   |
| 5   | PWMO   | <b>PWM Dimming Output;</b><br>Connect to gate of external MOSFET   |
| 6   | FBH    | <b>Voltage Feedback Positive;</b><br>Non inverting Input (+)   |
| 7   | FBL    | <b>Voltage Feedback Negative;</b><br>Inverting Input (-)   |
| 8   | COMP   | <b>Compensation Input;</b><br>Connect R and C network to pin for stability   |

Pin Configuration

| Pin | Symbol      | Function  |
|-----|-------------|---|
| 9   | OVFB        | <b>Output Overvoltage Protection Feedback;</b><br>Connect to resistive voltage divider to set overvoltage threshold.  |
| 10  | ST          | <b>Status Output;</b><br>Open drain diagnostic output to indicate fault condition.<br>Connect pull up resistor to pin.  |
| 11  | FREQ / SYNC | <b>Frequency Select or Synchronization Input;</b><br>Connect external resistor to GND to set frequency.<br>Or apply external clock signal for synchronization within frequency capture range. |
| 12  | GND         | <b>Ground;</b><br>Connect to system ground.   |
| 13  | EN / PWMI   | <b>Enable or PWM Input;</b><br>Apply logic high signal to enable device or PWM signal for dimming LED.  |
| 14  | IN          | <b>Supply Input;</b><br>Supply for internal biasing.  |
| EP  |             | <b>Exposed Pad;</b><br>Connect to external heat spreading Cu area with electrically GND (e.g. inner GND layer of multilayer PCB with thermal vias)  |

## 4 General Product Characteristics

### 4.1 Absolute Maximum Ratings

#### Absolute Maximum Ratings<sup>1)</sup>

$T_j = -40\text{ °C}$  to  $+150\text{ °C}$ ; all voltages with respect to ground, positive current flowing into pin (unless otherwise specified)

| Pos.                      | Parameter   | Symbol            | Limit Values |      | Unit | Conditions        |
|---------------------------|---|-------------------|--------------|------|------|-------------------|
|                           |   |                   | Min.         | Max. |      |                   |
| <b>Voltages</b>           |   |                   |              |      |      |                   |
| 4.1.1                     | IN<br>Supply Input                                | $V_{IN}$          | -0.3         | 45   | V    |                   |
| 4.1.2                     | EN / PWMI<br>Enable or PWM Input                  | $V_{EN}$          | -40          | 45   | V    |                   |
| 4.1.3                     | FBH-FBL;<br>Feedback Error Amplifier Differential | $V_{FBH}-V_{FBL}$ | -5.5         | 5.5  | V    |                   |
| 4.1.4                     | FBH;<br>Feedback Error Amplifier Positive Input   | $V_{FBH}$         | -0.3         | 45   | V    |                   |
| 4.1.5                     | FBL<br>Feedback Error Amplifier Negative Input    | $V_{FBL}$         | -0.3         | 45   | V    |                   |
| 4.1.6                     | OVFB  | $V_{OVP}$         | -0.3         | 5.5  | V    |                   |
| 4.1.7                     | Over Voltage Feedback Input                       |                   | -0.3         | 6.2  | V    | $t < 10s$         |
| 4.1.8                     | SWCS  | $V_{SWCS}$        | -0.3         | 5.5  | V    |                   |
| 4.1.9                     | Switch Current Sense Input                        |                   | -0.3         | 6.2  | V    | $t < 10s$         |
| 4.1.10                    | SWO   | $V_{SWO}$         | -0.3         | 5.5  | V    |                   |
| 4.1.11                    | Switch Gate Drive Output                          |                   | -0.3         | 6.2  | V    | $t < 10s$         |
| 4.1.12                    | SGND<br>Current Sense Switch GND                  | $V_{SGND}$        | -0.3         | 0.3  | V    |                   |
| 4.1.13                    | COMP  | $V_{COMP}$        | -0.3         | 5.5  | V    |                   |
| 4.1.14                    | Compensation Input                                |                   | -0.3         | 6.2  | V    | $t < 10s$         |
| 4.1.15                    | FREQ / SYNC; Frequency and                        | $V_{FREQ / SYNC}$ | -0.3         | 5.5  | V    |                   |
| 4.1.16                    | Synchronization Input                             |                   | -0.3         | 6.2  | V    | $t < 10s$         |
| 4.1.17                    | PWMO  | $V_{PWMO}$        | -0.3         | 5.5  | V    |                   |
| 4.1.18                    | PWM Dimming Output                                |                   | -0.3         | 6.2  | V    | $t < 10s$         |
| 4.1.19                    | ST  | $V_{ST}$          | -0.3         | 45   | V    |                   |
| 4.1.20                    | Diagnostic Status Output                          | $I_{ST}$          | -5           | 5    | mA   |                   |
| 4.1.21                    | IVCC  | $V_{IVCC}$        | -0.3         | 5.5  | V    |                   |
| 4.1.22                    | Internal Linear Voltage Regulator Output          |                   | -0.3         | 6.2  | V    | $t < 10s$         |
| <b>Temperatures</b>       |   |                   |              |      |      |                   |
| 4.1.23                    | Junction Temperature                              | $T_j$             | -40          | 150  | °C   | –                 |
| 4.1.24                    | Storage Temperature                               | $T_{stg}$         | -55          | 150  | °C   | –                 |
| <b>ESD Susceptibility</b> |   |                   |              |      |      |                   |
| 4.1.25                    | ESD Resistivity to GND                            | $V_{ESD,HBM}$     | -2           | 2    | kV   | HBM <sup>2)</sup> |



### Absolute Maximum Ratings<sup>1)</sup>

$T_j = -40 \text{ °C to } +150 \text{ °C}$ ; all voltages with respect to ground, positive current flowing into pin (unless otherwise specified)

| Pos.   | Parameter  | Symbol          | Limit Values |      | Unit | Conditions        |
|--------|--|-----------------|--------------|------|------|-------------------|
|        |  |                 | Min.         | Max. |      |                   |
| 4.1.26 | ESD Resistivity to GND                               | $V_{ESD,CDM}$   | -500         | 500  | V    | CDM <sup>3)</sup> |
| 4.1.27 | ESD Resistivity Pin 1, 7, 8, 14 (corner pins) to GND | $V_{ESD,CDM,C}$ | -750         | 750  | V    | CDM <sup>3)</sup> |

- 1) Not subject to production test, specified by design.
- 2) ESD susceptibility, Human Body Model "HBM" according to ANSI/ESDA/JEDEC JS-001 (1.5kΩ, 100pF)
- 3) ESD susceptibility, Charged Device Model "CDM" ESDA STM5.3.1 or ANSI/ESD S.5.3.1

*Note: Stresses above the ones listed here may cause permanent damage to the device. Exposure to absolute maximum rating conditions for extended periods may affect device reliability.*

*Note: Integrated protection functions are designed to prevent IC destruction under fault conditions described in the data sheet. Fault conditions are considered as "outside" normal operating range. Protection functions are not designed for continuous repetitive operation.*

## 4.2 Functional Range

| Pos.  | Parameter              | Symbol                  | Limit Values |      | Unit | Conditions                  |
|-------|------------------------|-------------------------|--------------|------|------|-----------------------------|
|       |                        |                         | Min.         | Max. |      |                             |
| 4.2.1 | Supply Voltage Input   | $V_{IN}$                | 4.75         | 45   | V    | $V_{IVCC} > V_{IVCC,RTH,d}$ |
| 4.2.2 | Feedback Voltage Input | $V_{FBH};$<br>$V_{FBL}$ | 4.5          | 45   | V    | –                           |
| 4.2.3 | Junction Temperature   | $T_j$                   | -40          | 150  | °C   | –                           |

*Note: Within the functional range the IC operates as described in the circuit description. The electrical characteristics are specified within the conditions given in the related electrical characteristics table.*

## 4.3 Thermal Resistance

*Note: This thermal data was generated in accordance with JEDEC JESD51 standards. For more information, go to [www.jedec.org](http://www.jedec.org).*

| Pos.  | Parameter                            | Symbol     | Limit Values |      |      | Unit | Conditions                 |
|-------|--------------------------------------|------------|--------------|------|------|------|----------------------------|
|       |                                      |            | Min.         | Typ. | Max. |      |                            |
| 4.3.1 | Junction to Case <sup>1) 2)</sup>    | $R_{thJC}$ | –            | 10   | –    | K/W  |                            |
| 4.3.2 | Junction to Ambient <sup>1) 3)</sup> | $R_{thJA}$ | –            | 47   | –    | K/W  | 2s2p                       |
| 4.3.3 |                                      | $R_{thJA}$ | –            | 54   | –    | K/W  | 1s0p + 600 mm <sup>2</sup> |
| 4.3.4 |                                      | $R_{thJA}$ | –            | 64   | –    | K/W  | 1s0p + 300 mm <sup>2</sup> |

- 1) Not subject to production test, specified by design.
- 2) Specified  $R_{thJC}$  value is simulated at natural convection on a cold plate setup (all pins and exposed pad are fixed to ambient temperature).  $T_a=25\text{°C}$ , IC is dissipating 1W.
- 3) Specified  $R_{thJA}$  value is according to JEDEC 2s2p (JESD 51-7) + (JESD 51-5) and JEDEC 1s0p (JESD 51-3) + heatsink area at natural convection on FR4 board; The device was simulated on a 76.2 x 114.3 x 1.5mm board. The 2s2p board has 2 outer copper layers (2 x 70μm Cu) and 2 inner copper layers (2 x 35μm Cu), A thermal via (diameter = 0.3mm and 25μm plating) array was applied under the exposed pad and connected the first outer layer (top) to the first inner layer and second outer layer (bottom) of the JEDEC PCB.  $T_a=25\text{°C}$ , IC is dissipating 1W.



## 5 Regulator

### 5.1 Description

The TLD5095 regulator is suitable for Boost, Buck, Buck-Boost, SEPIC and Flyback configurations. The constant output current is especially useful for light emitting diode (LED) applications. The regulator function is implemented by a pulse width modulated (PWM) current mode controller.

The PWM current mode controller uses the peak current through the external power switch and error in the output current to determine the appropriate pulse width duty cycle (on time) for constant output current. The current mode controller it provides a PWM signal to an internal gate driver which then outputs the same PWM signal to external n-channel enhancement mode metal oxide field effect transistor (MOSFET) power switch.

The current mode controller also has built-in slope compensation to prevent sub-harmonic oscillations which is a characteristic of current mode controllers operating at high duty cycles (>50% duty).

An additional built-in feature is an integrated soft start that limits the current through the inductor and external power switch during initialization. The soft start function gradually increases the inductor and switch current over 1 ms (typical) to minimize potential overvoltage at the output.

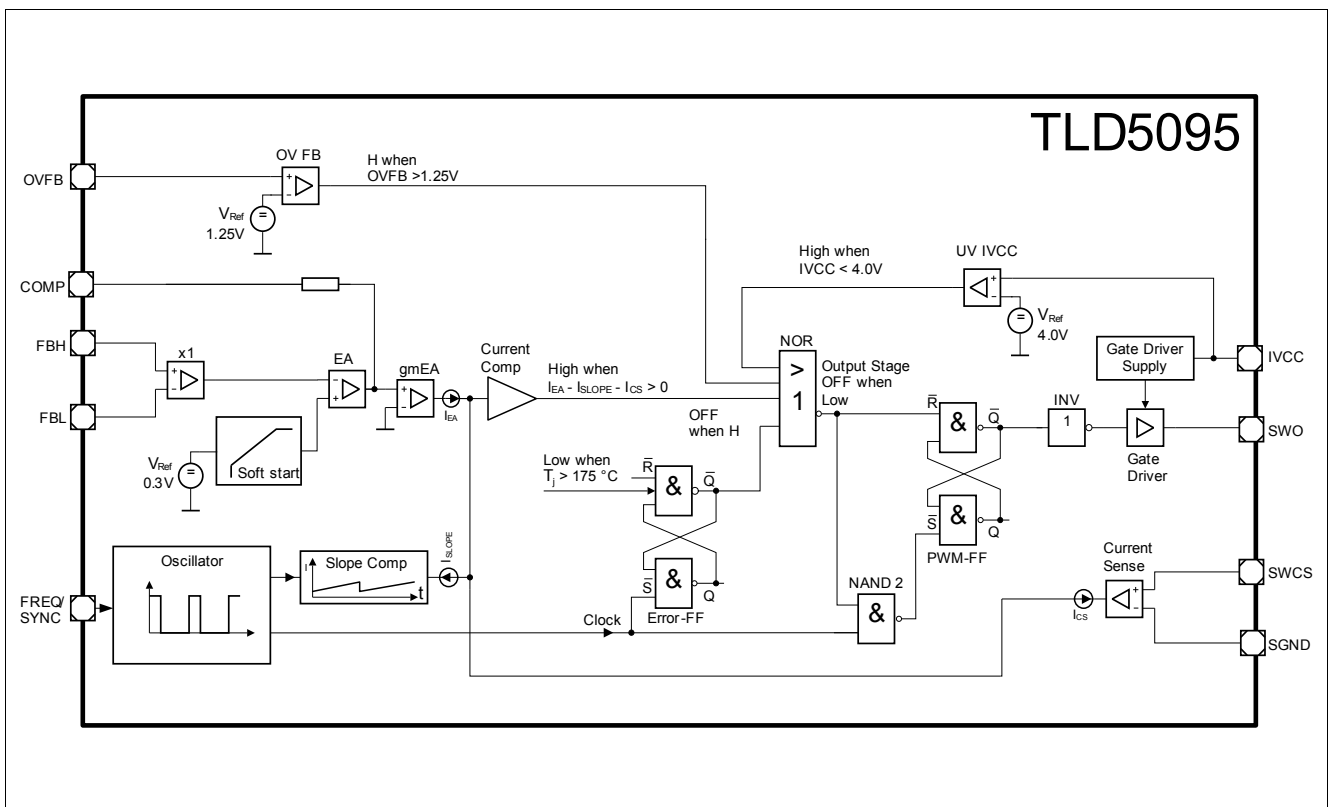

Figure 3 Regulator Block Diagram

## 5.2 Electrical Characteristics

$V_{IN} = 6V$  to  $40V$ ;  $4.5V \leq V_{FBH} \leq 40V$ ,  $4.5V \leq V_{FBL} \leq 40V$ ,  $T_J = -40 \cdot C$  to  $+150 \cdot C$ , all voltages with respect to ground, positive current flowing into pin; (unless otherwise specified)

| Pos. | Parameter | Symbol | Limit Values |      |      | Unit | Conditions |
|------|-----------|--------|--------------|------|------|------|------------|
|      |           |        | Min.         | Typ. | Max. |      |            |

### Regulator:

|        |                                    |  |      |      |      |         |  |
|--------|------------------------------------|--|------|------|------|---------|--|
| 5.2.1  | Feedback Reference Voltage         | $V_{REF}$  | 0.28 | 0.30 | 0.32 | V       | $V_{IN} = 19V$ ;<br>$V_{REF} = V_{FBH} - V_{FBL}$                                    |
| 5.2.2  | Voltage Line Regulation            | $\frac{\Delta V_{REF}}{\Delta V_{IN}}$             | –    | –    | 0.15 | %/V     | $V_{IN} = 6$ to $19V$ ;<br>$V_{BO} = 30V$ ;<br>$I_{BO} = 500mA$<br><b>Figure 25</b>  |
| 5.2.3  | Voltage Load Regulation            | $\frac{(\Delta V_{REF} / V_{REF})}{\Delta I_{BO}}$ | –    | –    | 5    | %/A     | $V_{IN} = 6V$ ;<br>$V_{BO} = 30V$ ;<br>$I_{BO} = 100$ to $500mA$<br><b>Figure 25</b> |
| 5.2.4  | Switch Peak Over Current Threshold | $V_{SWCS}$   | 130  | 150  | 170  | mV      | $V_{IN} = 6V$<br>$V_{FBH} = V_{FBL} = 5V$<br>$V_{COMP} = 3.5V$                       |
| 5.2.5  | Maximum Duty Cycle                 | $D_{MAX, fixed}$                                   | 90   | 93   | 95   | %       | Fixed frequency mode   |
| 5.2.6  | Maximum Duty Cycle                 | $D_{MAX, sync}$                                    | 88   | –    | –    | %       | Synchronization mode   |
| 5.2.7  | Soft Start Ramp                    | $t_{SS}$   | 350  | 1000 | 1500 | $\mu s$ | $V_{FB}$ rising from 5% to 95% of $V_{FB}$ , typ.                                    |
| 5.2.8  | Feedback Input Current             | $I_{FBX}$  | -10  | -50  | -100 | $\mu A$ | $V_{FBH} - V_{FBL} = 0.3V$   |
| 5.2.9  | Switch Current Sense Input Current | $I_{SWCS}$   | 10   | 50   | 100  | $\mu A$ | $V_{SWCS} = 150mV$   |
| 5.2.10 | Input Undervoltage Shutdown        | $V_{IN, off}$                                      | 3.75 | –    | –    | V       | $V_{IN}$ decreasing  |
| 5.2.11 | Input Voltage Startup              | $V_{IN, on}$                                       | –    | –    | 4.75 | V       | $V_{IN}$ increasing  |

### Gate Driver for external Switch

|        |   |                |     |     |     |    |  |
|--------|---|----------------|-----|-----|-----|----|--|
| 5.2.12 | Gate Driver Peak Sourcing Current <sup>1)</sup> | $I_{SWO, SRC}$ | –   | 380 | –   | mA | $V_{SWO} = 3.5V$                                 |
| 5.2.13 | Gate Driver Peak Sinking Current <sup>1)</sup>  | $I_{SWO, SNK}$ | –   | 550 | –   | mA | $V_{SWO} = 1.5V$                                 |
| 5.2.14 | Gate Driver Output Rise Time                    | $t_{R, SWO}$   | –   | 30  | 60  | ns | $C_{L, SWO} = 3.3nF$ ;<br>$V_{SWO} = 1V$ to $4V$ |
| 5.2.15 | Gate Driver Output Fall Time                    | $t_{F, SWO}$   | –   | 20  | 40  | ns | $C_{L, SWO} = 3.3nF$ ;<br>$V_{SWO} = 1V$ to $4V$ |
| 5.2.16 | Gate Driver Output Voltage <sup>1)</sup>        | $V_{SWO}$      | 4.5 | –   | 5.5 | V  | $C_{L, SWO} = 3.3nF$ ;                           |

1) Not subject to production test, specified by design

## 6 Oscillator and Synchronization

### 6.1 Description

R\_OSC vs. switching frequency

The internal oscillator is used to determine the switching frequency of the multistage regulator. The switching frequency can be selected from 100 kHz to 500 kHz with an external resistor to GND. To set the switching frequency with an external resistor the following formula can be applied.

$$R_{FREQ} = \frac{1}{\left(141 \times 10^{-12} \left[\frac{s}{\Omega}\right]\right) \times \left(f_{FREQ} \left[\frac{1}{s}\right]\right)} - \left(3.5 \times 10^3 [\Omega]\right) [\Omega]$$

In addition, the oscillator is capable of changing from the frequency set by the external resistor to a synchronized frequency from an external clock source. If an external clock source is provided on the pin FREQ/SYNC, then the internal oscillator synchronizes to this external clock frequency and the multistage regulator switches at the synchronized frequency. The synchronization frequency capture range is 250 kHz to 500 kHz.

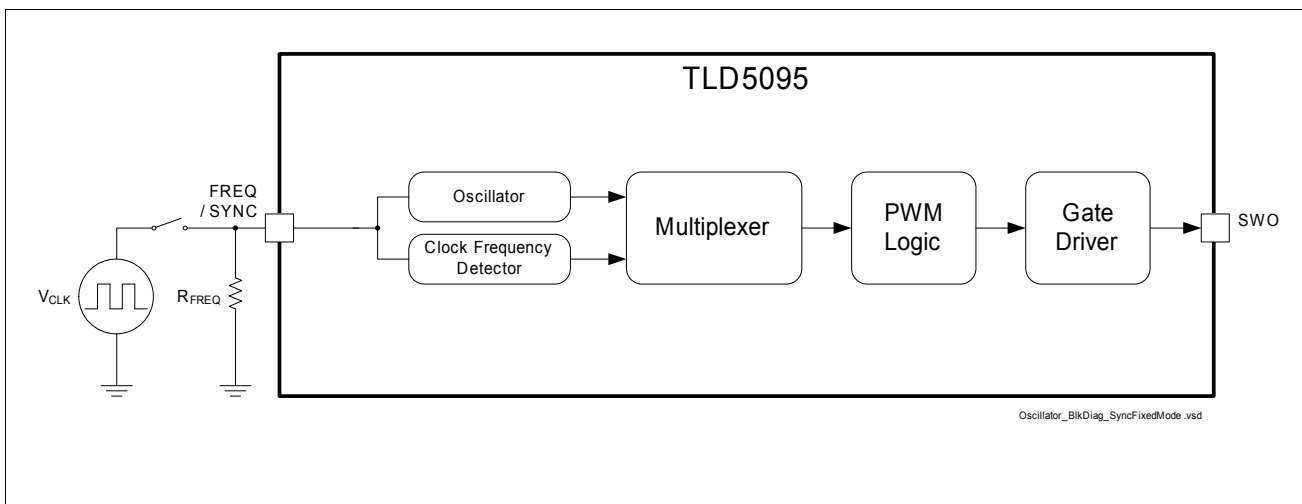

Figure 4 Oscillator and Synchronization Block Diagram and Simplified Application Circuit

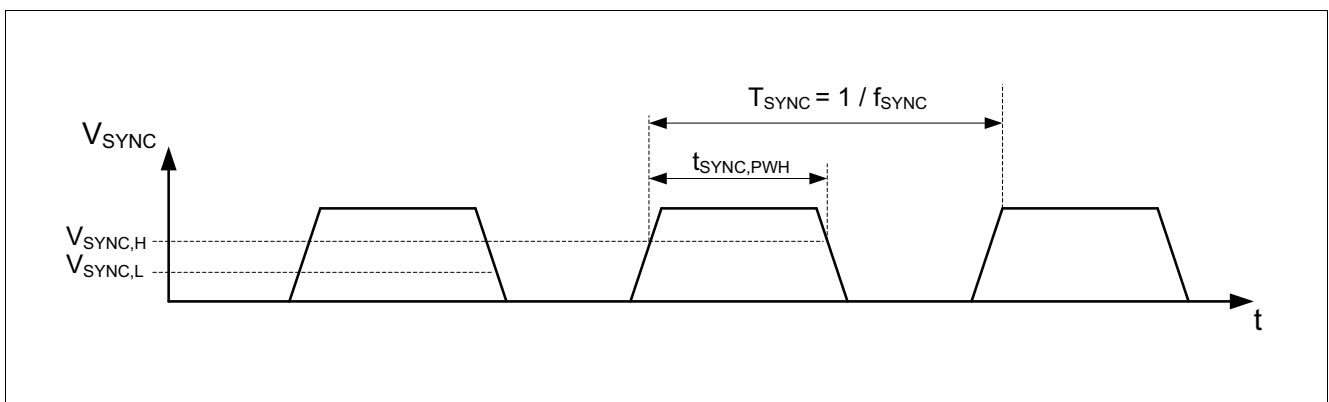

Figure 5 Synchronization Timing Diagram

## 6.2 Electrical Characteristics

$V_{IN} = 6V$  to  $40V$ ;  $4.5V \leq V_{FBH} \leq 40V$ ,  $4.5V \leq V_{FBL} \leq 40V$ ,  $T_j = -40 \cdot C$  to  $+150 \cdot C$ , all voltages with respect to ground, positive current flowing into pin; (unless otherwise specified)

| Pos. | Parameter | Symbol | Limit Values |      |      | Unit | Conditions |
|------|-----------|--------|--------------|------|------|------|------------|
|      |           |        | Min.         | Typ. | Max. |      |            |

### Oscillator:

|       |                                       |            |      |      |      |         |  |
|-------|---------------------------------------|------------|------|------|------|---------|--|
| 6.2.1 | Oscillator Frequency                  | $f_{FREQ}$ | 250  | 300  | 350  | kHz     | $R_{FREQ} = 20k\Omega$                               |
| 6.2.2 | Oscillator Frequency Adjustment Range | $f_{FREQ}$ | 100  | –    | 500  | kHz     | 17% internal tolerance + external resistor tolerance |
| 6.2.3 | FREQ / SYNC Supply Current            | $I_{FREQ}$ | –    | –    | -700 | $\mu A$ | $V_{FREQ} = 0 V$                                     |
| 6.2.4 | Frequency Voltage                     | $V_{FREQ}$ | 1.16 | 1.24 | 1.32 | V       | $f_{FREQ} = 100 kHz$                                 |

### Synchronization

|       |   |                |     |   |     |     |               |
|-------|---|----------------|-----|---|-----|-----|---------------|
| 6.2.5 | Synchronization Frequency Capture Range       | $f_{SYNC}$     | 250 | – | 500 | kHz | –             |
| 6.2.6 | Synchronization Signal High Logic Level Valid | $V_{SYNC,H}$   | 3.0 | – | –   | V   | <sup>1)</sup> |
| 6.2.7 | Synchronization Signal Low Logic Level Valid  | $V_{SYNC,L}$   | –   | – | 0.8 | V   | <sup>1)</sup> |
| 6.2.8 | Synchronization Signal Logic High Pulse Width | $t_{SYNC,PWH}$ | 200 | – | –   | ns  | <sup>1)</sup> |

1) Synchronization of external PWM ON signal to falling edge

Typical Performance Characteristics of Oscillator

Switching Frequency  $f_{SW}$  versus  
Frequency Select Resistor to GND  $R_{FREQ/SYNC}$

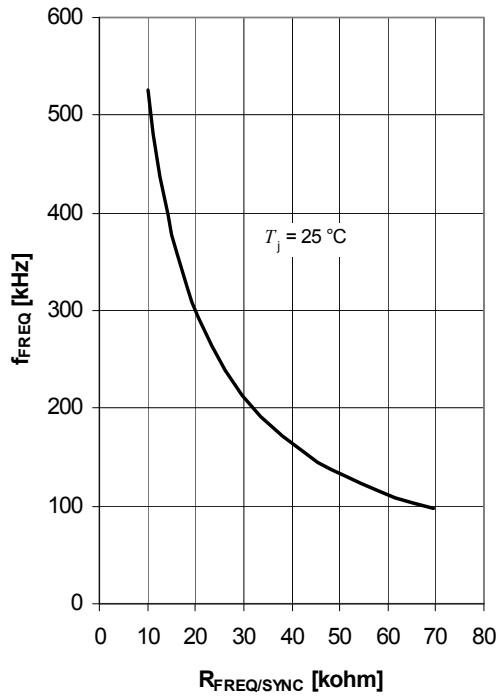

## 7 Enable and Dimming Function

### 7.1 Description

The enable function powers on or off the device. A valid logic low signal on enable pin EN/PWMI powers off the device and current consumption is less than 10  $\mu\text{A}$ . A valid logic high enable signal on enable pin EN/PWMI powers on the device. The enable function features an integrated pull down resistor which ensures that the IC is shut down and the power switch is off in case the enable pin EN is left open.

In addition to the enable function described above, the EN/PWMI pin detects a pulse width modulated (PWM) input signal that is fed through to an internal gate driver. The internal gate driver outputs the same PWM signal on the PWMO pin to an external n-channel enhancement mode MOSFET for PWM dimming an LED load. PWM dimming an LED is a commonly practiced dimming method to prevent color shift in an LED light source. Moreover the PWM output function may also be used for to drive other types of loads besides LED.

The enable and PWM input function share the same pin. Therefore a valid logic low signal at the EN/PWMI pin needs to differentiate between an enable power off signal or an PWM low signal. The device differentiates between an enable off command and PWM dimming signal by requiring the signal at the EN/PWMI pin to stay low for a minimum of 8 ms.

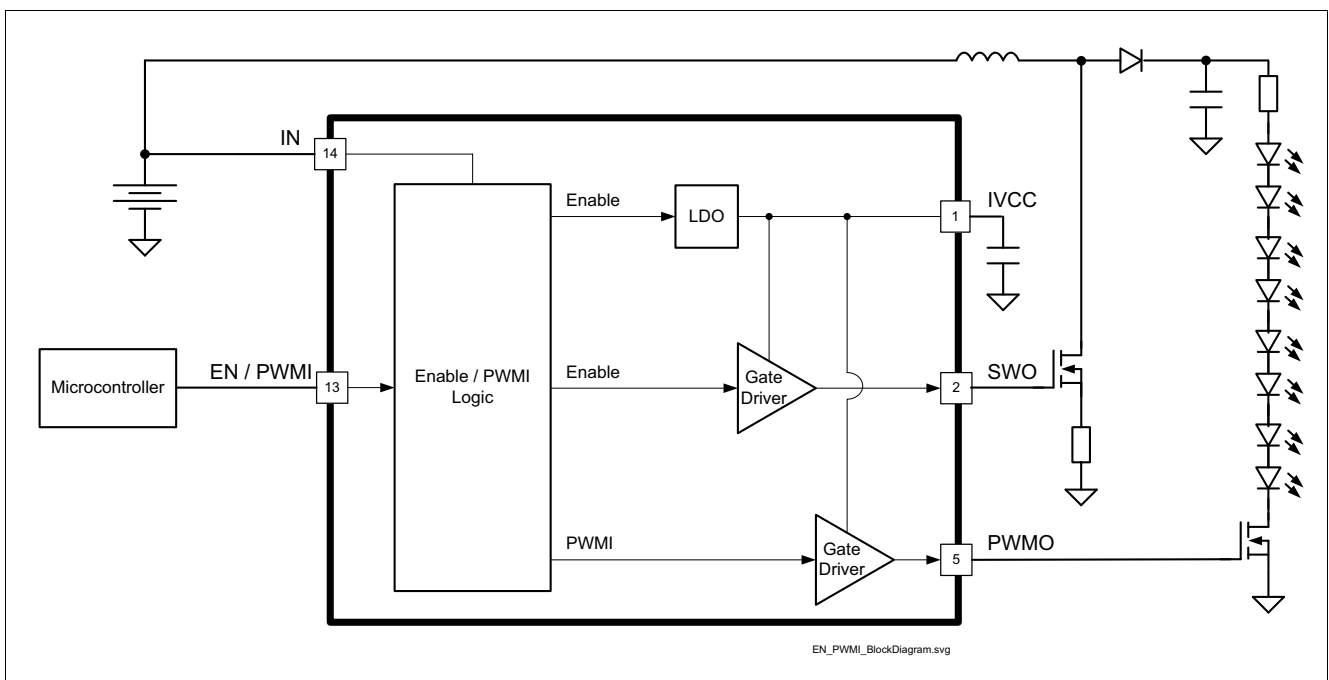

Figure 6 Block Diagram and Simplified Application Circuit Enable and LED Dimming

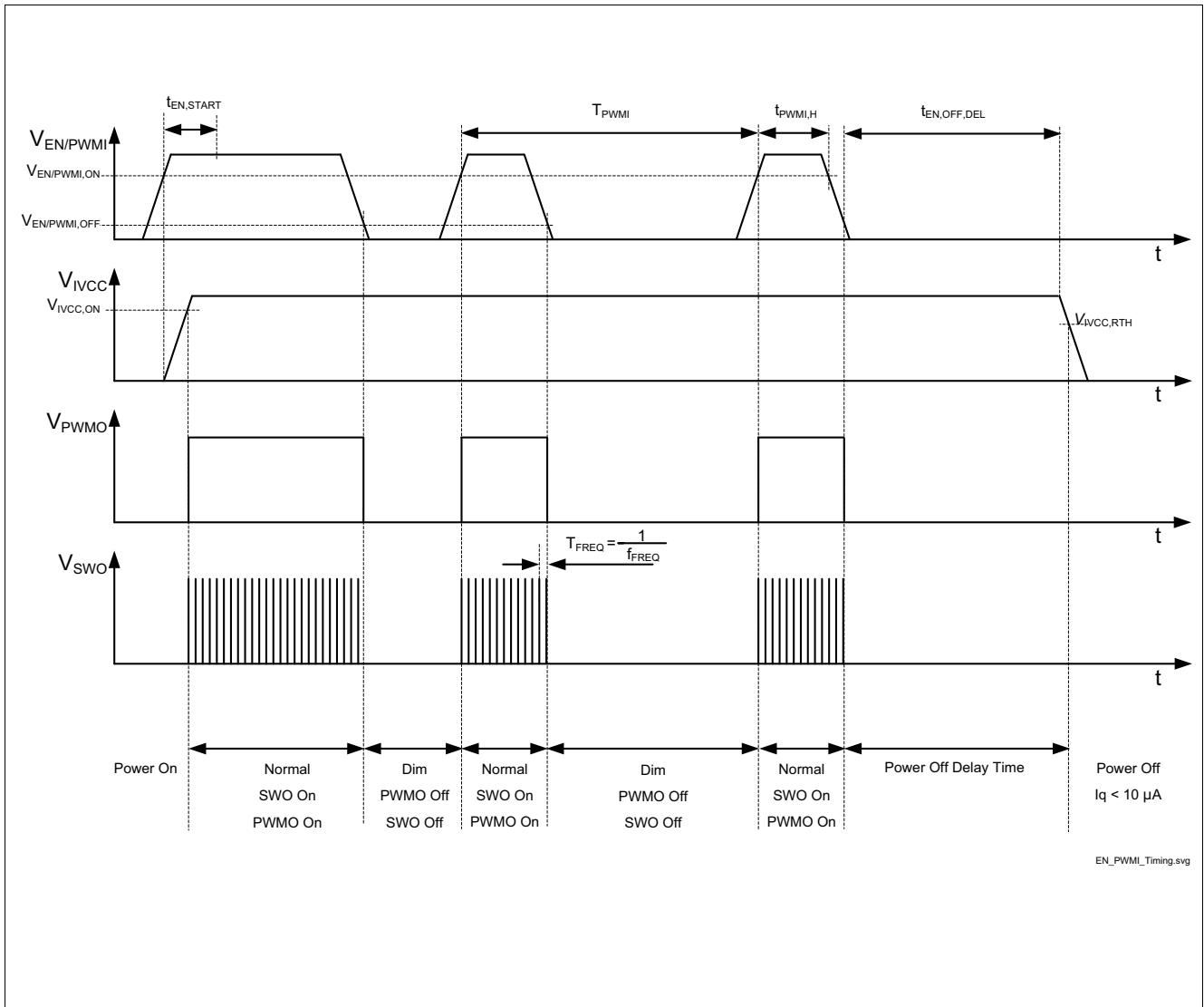

Figure 7 Timing Diagram Enable and LED Dimming

## 7.2 Electrical Characteristics

$V_{IN} = 6V$  to  $40V$ ;  $4.5V \leq V_{FBH} \leq 40V$ ,  $4.5V \leq V_{FBL} \leq 40V$ ,  $T_j = -40 \cdot C$  to  $+150 \cdot C$ , all voltages with respect to ground, positive current flowing into pin; (unless otherwise specified)

| Pos.                     | Parameter                      | Symbol            | Limit Values |      |      | Unit | Conditions |
|--------------------------|--------------------------------|-------------------|--------------|------|------|------|------------|
|                          |                                |                   | Min.         | Typ. | Max. |      |            |
| <i>Enable/PWM Input:</i> |                                |                   |              |      |      |      |            |
| 7.2.1                    | Enable/PWMI Turn On Threshold  | $V_{EN/PWMI,ON}$  | 3.0          | –    |      | V    | –          |
| 7.2.2                    | Enable/PWMI Turn Off Threshold | $V_{EN/PWMI,OFF}$ | –            | –    | 0.8  | V    | –          |
| 7.2.3                    | Enable/PWMI Hysteresis         | $V_{EN/PWMI,HYS}$ | 50           | 200  | 400  | mV   | –          |



**Enable and Dimming Function**

$V_{IN} = 6V$  to  $40V$ ;  $4.5V \leq V_{FBH} \leq 40V$ ,  $4.5V \leq V_{FBL} \leq 40V$ ,  $T_j = -40 \cdot C$  to  $+150 \cdot C$ , all voltages with respect to ground, positive current flowing into pin; (unless otherwise specified)

| Pos.  | Parameter                      | Symbol           | Limit Values |      |      | Unit    | Conditions             |
|-------|--------------------------------|------------------|--------------|------|------|---------|------------------------|
|       |                                |                  | Min.         | Typ. | Max. |         |                        |
| 7.2.4 | Enable/PWMI High Input Current | $I_{EN/PWMI,H}$  | –            | –    | 30   | $\mu A$ | $V_{EN/PWMI} = 16.0 V$ |
| 7.2.5 | Enable/PWMI Low Input Current  | $I_{EN/PWMI,L}$  | –            | 0.1  | 1    | $\mu A$ | $V_{EN/PWMI} = 0.5 V$  |
| 7.2.6 | Enable Turn Off Delay Time     | $t_{EN,OFF,DEL}$ | 8            | 10   | 12   | ms      | –                      |
| 7.2.7 | PWMI Min Duty Time             | $t_{PWMI,H}$     | 4            | –    | –    | $\mu s$ |                        |
| 7.2.8 | Enable Startup Time            | $t_{EN,START}$   | 100          | –    | –    | $\mu s$ |                        |

**Gate Driver for Dimming Switch:**

|        |  |                |     |     |     |    |   |
|--------|--|----------------|-----|-----|-----|----|---|
| 7.2.9  | PWMO Gate Driver Peak Sourcing Current <sup>1)</sup> | $I_{PWMO,SR}$  | –   | 230 | –   | mA | $V_{PWMO} = 3.5V$                                 |
| 7.2.10 | PWMO Gate Driver Peak Sinking Current <sup>1)</sup>  | $I_{PWMO,SNK}$ | –   | 370 | –   | mA | $V_{PWMO} = 1.5V$                                 |
| 7.2.11 | PWMO Gate Driver Output Rise Time                    | $t_{R,PWMO}$   | –   | 50  | 100 | ns | $C_{L,PWMO} = 3.3nF$ ;<br>$V_{PWMO} = 1V$ to $4V$ |
| 7.2.12 | PWMO Gate Driver Output Fall Time                    | $t_{F,PWMO}$   | –   | 30  | 60  | ns | $C_{L,PWMO} = 3.3nF$ ;<br>$V_{PWMO} = 1V$ to $4V$ |
| 7.2.13 | PWMO Gate Driver Output Voltage                      | $V_{PWMO}$     | 4.5 | –   | 5.5 | V  | $C_{L,PWMO} = 3.3nF$ ;                            |

**Current Consumption**

|        |  |             |   |   |    |         |  |
|--------|--|-------------|---|---|----|---------|--|
| 7.2.14 | Current Consumption, Shutdown Mode             | $I_{q,off}$ | – | – | 10 | $\mu A$ | $V_{EN/PWMI} = 0.8 V$ ;<br>$T_j \leq 105C$ ; $V_{IN} = 16V$                                |
| 7.2.15 | Current Consumption, Active Mode <sup>2)</sup> | $I_{q,on}$  | – | – | 7  | mA      | $V_{EN/PWMI} \geq 4.75 V$ ;<br>$I_{BO} = 0 mA$ ;<br>$V_{IN} = 16V$<br>$V_{SWO} = 0\% Duty$ |

1) Not subject to production test, specified by design

2) Dependency on switching frequency and gate charge of external switches.

## 8 Linear Regulator

### 8.1 Description

The internal linear voltage regulator supplies the internal gate drivers with a typical voltage of 5 V and current up to  $I_{LIM,min}$  (parameter 8.2.2). An external output capacitor with ESR lower than  $R_{IVCC,ESR}$  (parameter 8.2.5) is required on pin IVCC for stability and buffering transient load currents. During normal operation the external MOSFET switches will draw transient currents from the linear regulator and its output capacitor. Proper sizing of the output capacitor must be considered to supply sufficient peak current to the gate of the external MOSFET switches.

#### Integrated undervoltage protection for the external switching MOSFET:

An integrated undervoltage reset threshold circuit monitors the linear regulator output voltage ( $V_{IVCC}$ ) and resets the device in case the output voltage falls below the IVCC undervoltage reset switch OFF threshold ( $V_{IVCC,RTH,d}$ ). The undervoltage reset threshold for the IVCC pin helps to protect the external switches from excessive power dissipation by ensuring the gate drive voltage is sufficient to enhance the gate of an external logic level n-channel MOSFET.

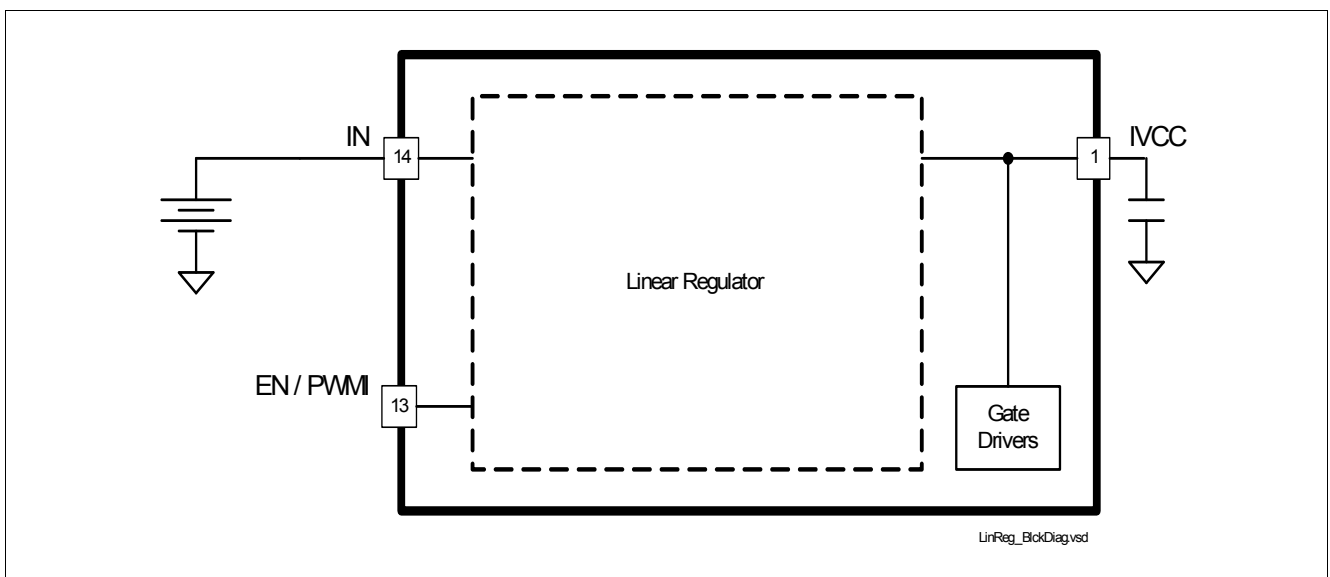

Figure 8 Voltage Regulator Block Diagram and Simplified Application Circuit

## 8.2 Electrical Characteristics

$V_{IN} = 6V$  to  $40V$ ;  $4.5V \leq V_{FBH} \leq 40V$ ,  $4.5V \leq V_{FBL} \leq 40V$ ,  $T_j = -40 \cdot C$  to  $+150 \cdot C$ , all voltages with respect to ground, positive current flowing into pin; (unless otherwise specified)

| Pos.  | Parameter                    | Symbol           | Limit Values |      |      | Unit     | Conditions   |
|-------|------------------------------|------------------|--------------|------|------|----------|--|
|       |                              |                  | Min.         | Typ. | Max. |          |  |
| 8.2.1 | Output Voltage               | $V_{IVCC}$       | 4.6          | 5    | 5.4  | V        | $6V \leq V_{IN} \leq 45V$<br>$0.1mA \leq I_{IVCC} \leq 35mA$ |
| 8.2.2 | Output Current Limitation    | $I_{LIM}$        | 51           |      | 90   | mA       | $V_{IN} = 13.5V$<br>$V_{IVCC} = 4.5V$                        |
| 8.2.3 | Drop out Voltage             | $V_{DR}$         |              |      | 1.4  | V        | $I_{IVCC} = 50mA$ <sup>1)</sup>                              |
| 8.2.4 | Output Capacitor             | $C_{IVCC}$       | 0.47         |      | –    | $\mu F$  | <sup>2)</sup>  |
| 8.2.5 | Output Capacitor ESR         | $R_{IVCC,ESR}$   |              |      | 0.5  | $\Omega$ | $f = 10kHz$  |
| 8.2.6 | Undervoltage Reset Headroom  | $V_{IVCC,HDRM}$  | 100          | –    | –    | mV       | $V_{IVCC}$ decreasing<br>$V_{IVCC} - V_{IVCC,RTH,d}$         |
| 8.2.7 | Undervoltage Reset Threshold | $V_{IVCC,RTH,d}$ | 4.0          | –    | –    | V        | $V_{IVCC}$ decreasing  |
| 8.2.8 | Undervoltage Reset Threshold | $V_{IVCC,RTH,i}$ | –            | –    | 4.5  | V        | $V_{IVCC}$ increasing  |

1) Measured when the output voltage  $V_{CC}$  has dropped 100 mV from its nominal value.

2) Minimum value given is needed for regulator stability; application might need higher capacitance than the minimum.

## 9 Protection and Diagnostic Functions

### 9.1 Description

The TLD5095EL has integrated circuits to diagnose and protect against output overvoltage, open load, open feedback and overtemperature faults. In case any of the four fault conditions occur the Status output ST will output an active logic low signal to communicate that a fault has occurred. During an overvoltage or open load condition the gate driver outputs SWO and PWMO will turn off. **Figure 11** illustrates the various open load and open feedback conditions. In the event of an overtemperature condition (**Figure 14**) the integrated thermal shutdown function turns off the gate drivers and internal linear voltage regulator. The typical junction shutdown temperature is 175°C. After cooling down the IC will automatically restart operation. Thermal shutdown is an integrated protection function designed to prevent immediate IC destruction and is not intended for continuous use in normal operation.

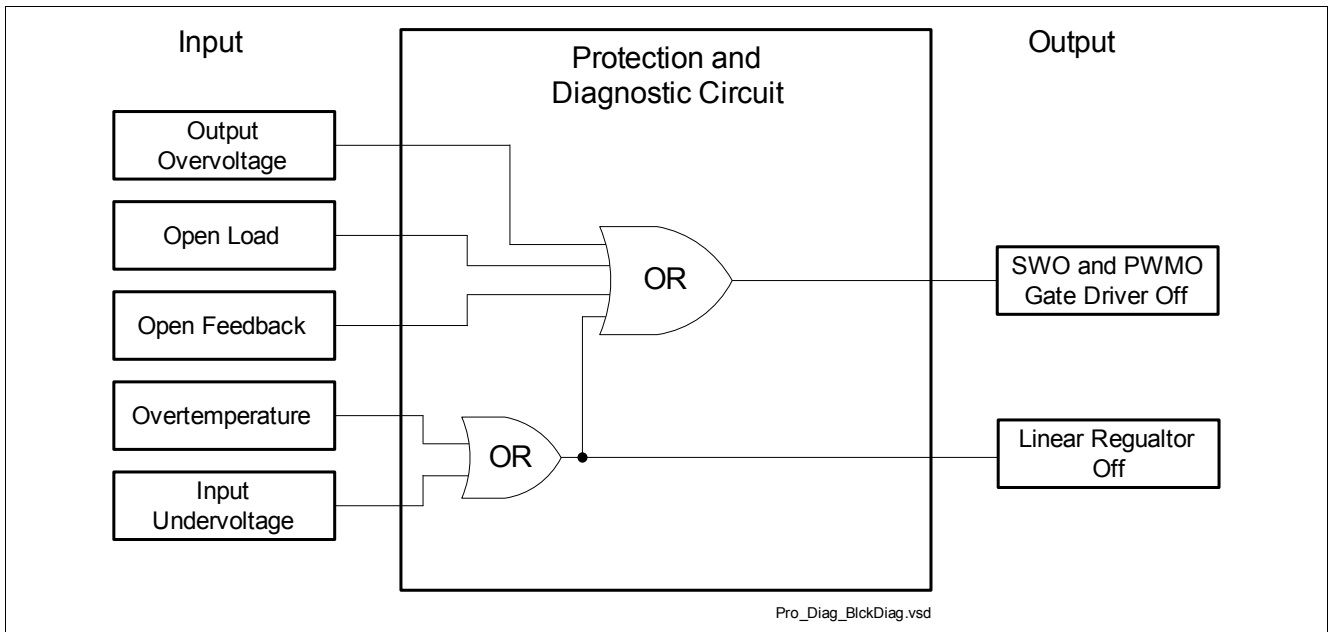

**Figure 9 Protection and Diagnostic Function Block Diagram**

| Input           |        | Output |     |          |          |
|-----------------|--------|--------|-----|----------|----------|
| Condition       | Level* | ST     | SWO | PWMO     | IVCC     |
| Overvoltage     | False  | H      | Sw* | H or Sw* | Active   |
|                 | True   | L      | L   | L        | Active   |
| Open Load       | False  | H      | Sw* | H or Sw* | Active   |
|                 | True   | L      | L   | L        | Active   |
| Open Feedback   | False  | H      | Sw* | H or Sw* | Active   |
|                 | True   | L      | L   | L        | Active   |
| Overtemperature | False  | H      | Sw* | H or Sw* | Active   |
|                 | True   | L      | L   | L        | Shutdown |

\*Note:  
 Sw = Switching  
 False = Condition does not exist  
 True = Condition does exist

Pro\_Diag\_TT.vsd

**Figure 10 Status Output Truth Table**

Protection and Diagnostic Functions

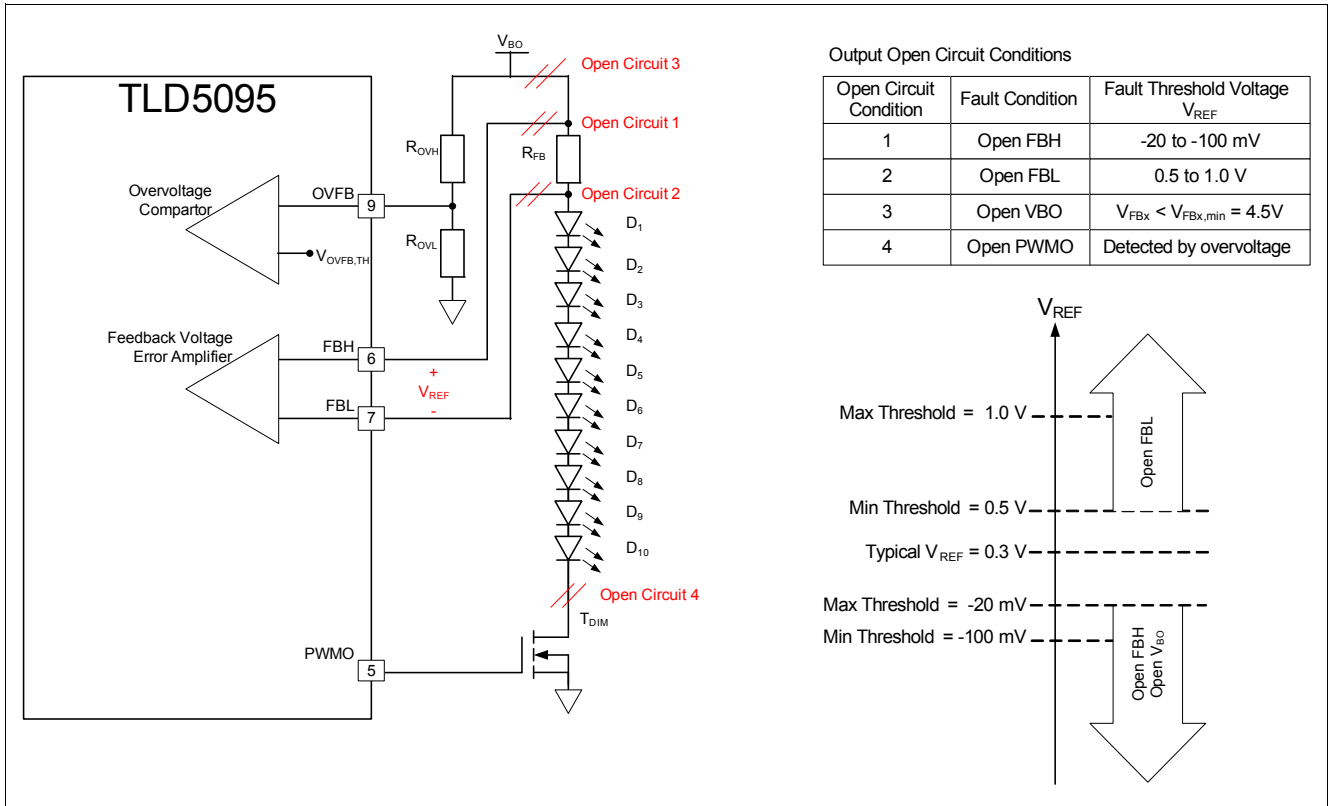

Figure 11 Open Load and Open Feedback Conditions

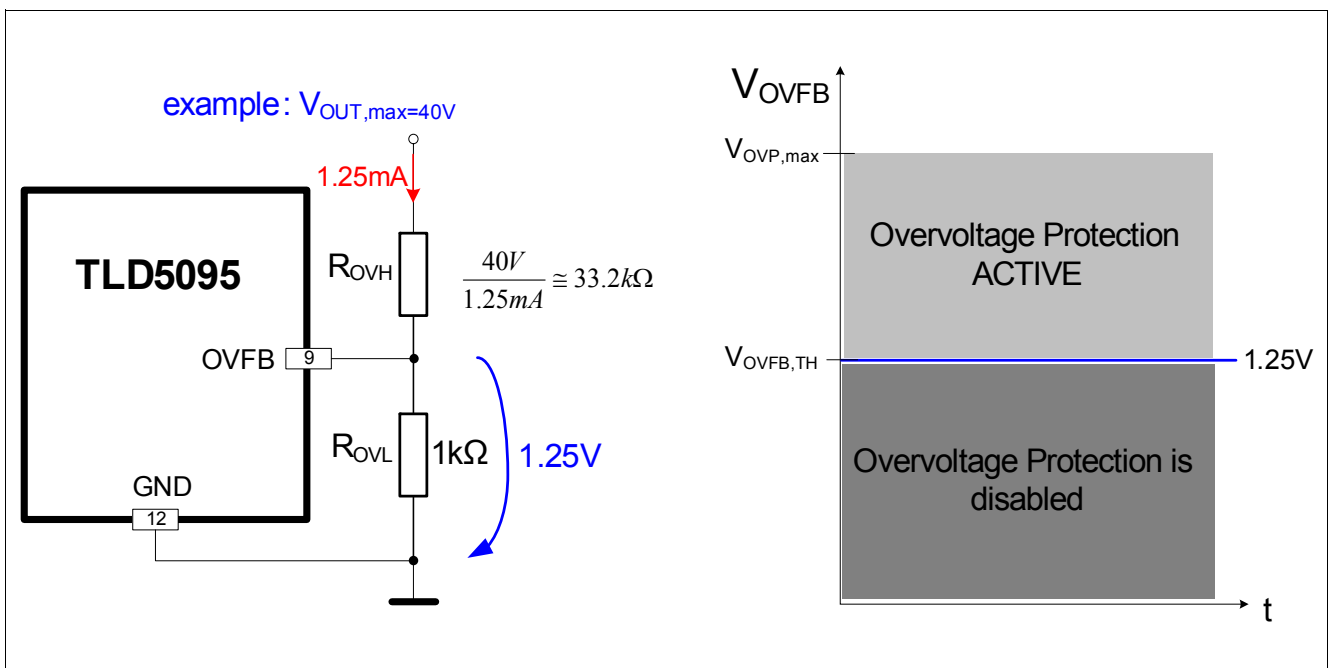

Figure 12 Overvoltage Protection description

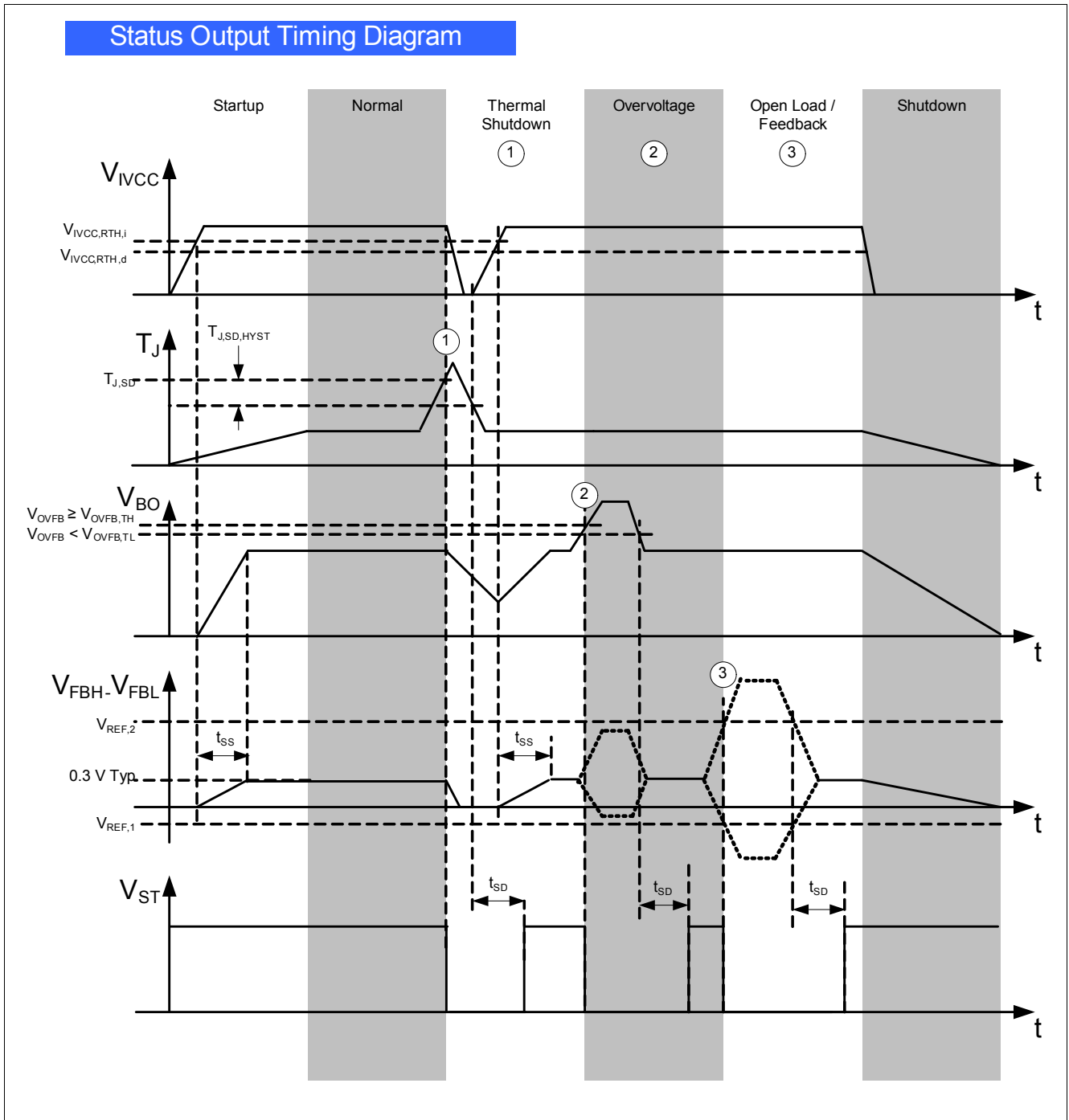

Figure 13 Status Output Timing Diagram

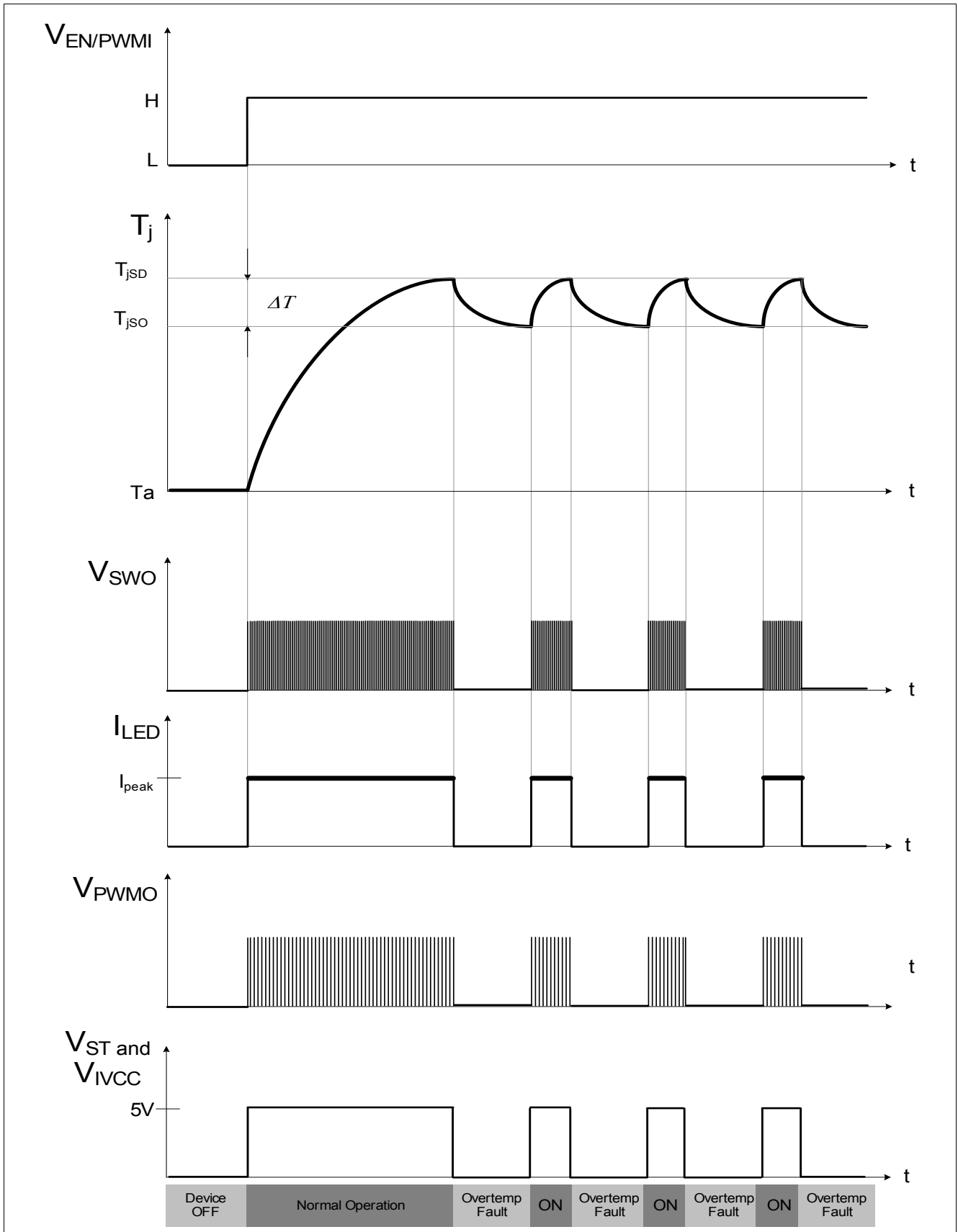

Figure 14 Device overtemperature protection behavior



## 9.2 Electrical Characteristics

$V_{IN} = 6V$  to  $40V$ ;  $4.5V \leq V_{FBH} \leq 40V$ ,  $4.5V \leq V_{FBL} \leq 40V$ ,  $T_j = -40 \text{ }^\circ\text{C}$  to  $+150 \text{ }^\circ\text{C}$ , all voltages with respect to ground, positive current flowing into pin; (unless otherwise specified)

| Pos. | Parameter | Symbol | Limit Values |      |      | Unit | Conditions |
|------|-----------|--------|--------------|------|------|------|------------|
|      |           |        | Min.         | Typ. | Max. |      |            |

### Status Output:

|       |                           |               |   |    |     |               |                       |
|-------|---------------------------|---------------|---|----|-----|---------------|-----------------------|
| 9.2.1 | Status Output Voltage Low | $V_{ST,LOW}$  | – | –  | 0.4 | V             | $I_{ST} = 1\text{mA}$ |
| 9.2.2 | Status Sink Current Limit | $I_{ST,MAX}$  | 2 | –  | –   | mA            | $V_{ST} = 1\text{V}$  |
| 9.2.3 | Status Output Current     | $I_{ST,HIGH}$ | – | –  | 1   | $\mu\text{A}$ | $V_{ST} = 5\text{V}$  |
| 9.2.4 | Status Delay Time         | $t_{SD}$      | 8 | 10 | 12  | ms            | –                     |

### Temperature Protection:

|       |                                      |                 |     |     |     |                  |   |
|-------|--------------------------------------|-----------------|-----|-----|-----|------------------|---|
| 9.2.5 | Over Temperature Shutdown            | $T_{j,SD}$      | 160 | 175 | 190 | $^\circ\text{C}$ | – |
| 9.2.6 | Over Temperature Shutdown Hysteresis | $T_{j,SD,HYST}$ | –   | 15  | –   | $^\circ\text{C}$ | – |

### Overvoltage Protection:

|        |   |                |      |      |      |               |                           |
|--------|---|----------------|------|------|------|---------------|---------------------------|
| 9.2.7  | Output Over Voltage Feedback Threshold Increasing | $V_{OVFB,TH}$  | 1.21 | 1.25 | 1.29 | V             | –                         |
| 9.2.8  | Output Over Voltage Feedback Hysteresis           | $V_{OVFB,HYS}$ | 50   | –    | 150  | mV            | Output Voltage decreasing |
| 9.2.9  | Over Voltage Reaction Time                        | $t_{OVPRR}$    | 2    | –    | 10   | $\mu\text{s}$ | Output Voltage decreasing |
| 9.2.10 | Over Voltage Feedback Input Current               | $I_{OVFB}$     | -1   | 0.1  | 1    | $\mu\text{A}$ | $V_{OVFB} = 1.25\text{V}$ |

### Open Load and Open Feedback Diagnostics

|        |                              |               |      |   |     |    |  |
|--------|------------------------------|---------------|------|---|-----|----|--|
| 9.2.11 | Open Load/Feedback Threshold | $V_{REF,1,3}$ | -100 | – | -20 | mV | $V_{REF} = V_{FBH} - V_{FBL}$<br>Open Circuit 1 or 3 |
| 9.2.12 | Open Feedback Threshold      | $V_{REF,2}$   | 0.5  | – | 1   | V  | $V_{REF} = V_{FBH} - V_{FBL}$<br>Open Circuit 2      |

*Note: Integrated protection functions are designed to prevent IC destruction under fault conditions described in the data sheet. Fault conditions are considered as “outside” normal operating range. Protection functions are not designed for continuous repetitive operation.*

## 10 Application Information

Note: The following information is given as a hint for the implementation of the device only and shall not be regarded as a description or warranty of a certain functionality, condition or quality of the device.

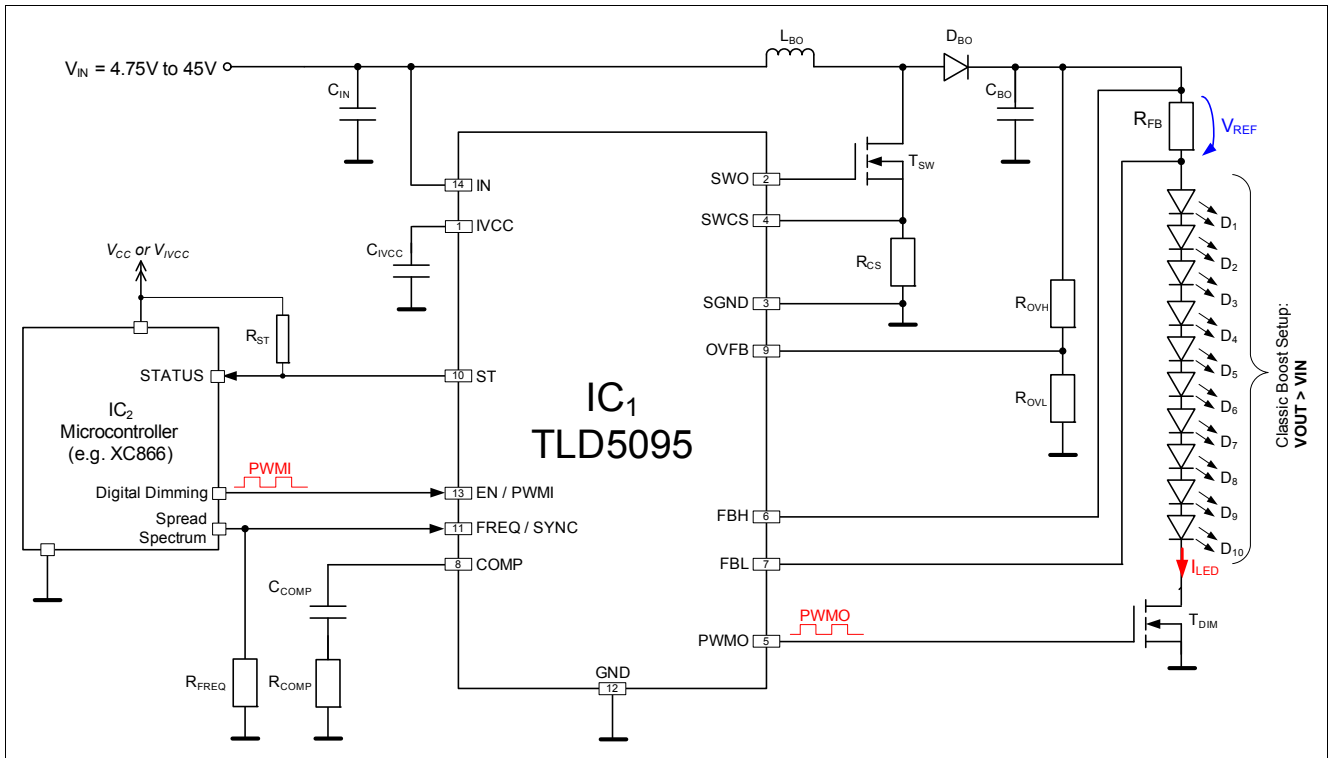

Figure 15 Boost to Ground Application Circuit - B2G (Boost configuration)

| Reference Designator                | Value                             | Manufacturer | Part Number           | Type       | Quantity |
|-------------------------------------|-----------------------------------|--------------|-----------------------|------------|----------|
| D <sub>1</sub> - 10                 | White                             | Osram        | LUW H9GP              | LED        | 10       |
| D <sub>BO</sub>                     | Schottky, 3 A, 100 V <sub>R</sub> | Vishay       | SS3H10                | Diode      | 1        |
| C <sub>IN</sub> , C <sub>BO</sub>   | 100 uF, 50V                       | Panasonic    | EEEFK1H101GP          | Capacitor  | 2        |
| C <sub>COMP</sub>                   | 10 nF                             | EPCOS        | X7R                   | Capacitor  | 1        |
| C <sub>IVCC</sub>                   | 1uF , 6.3V                        | EPCOS        | MLCC CCNPZC105KBW X7R | Capacitor  | 1        |
| IC <sub>1</sub>                     | --                                | Infineon     | TLD5095               | IC         | 1        |
| IC <sub>2</sub>                     | --                                | Infineon     | XC866                 | IC         | 1        |
| L <sub>BO</sub>                     | 100 uH                            | Coilcraft    | MSS1278T-104ML        | Inductor   | 1        |
| R <sub>COMP</sub>                   | 10 kΩ, 1%                         | Panasonic    | ERJ3EKF1002V          | Resistor   | 1        |
| R <sub>FB</sub>                     | 820 mΩ, 1%                        | Panasonic    | ERJ14BQFR82U          | Resistor   | 1        |
| R <sub>FREQ</sub> , R <sub>ST</sub> | 20 kΩ, 1%                         | Panasonic    | ERJ3EKF2002V          | Resistor   | 2        |
| R <sub>OVH</sub>                    | 33.2 kΩ, 1%                       | Panasonic    | ERJ3EKF3322V          | Resistor   | 1        |
| R <sub>OVL</sub>                    | 1 kΩ, 1%                          | Panasonic    | ERJ3EKF1001V          | Resistor   | 1        |
| R <sub>CS</sub>                     | 50 mΩ, 1%                         | Panasonic    | ERJB1CFR05U           | Resistor   | 1        |
| T <sub>DIM</sub> , T <sub>SW</sub>  | Dual N-ch enh. (60V, 20A)         | Infineon     | IPG20N06S4L-26        | Transistor | 1        |
|                                     | alternativ: 100V N-ch, 35A        | Infineon     | IPG20N10S4L-22        | Transistor | 2        |
|                                     | alternativ: 60V N-ch, 2.6A        | Infineon     | BSP318S               | Transistor | 2        |

Figure 16 Bill of Materials for B2G Application Circuit

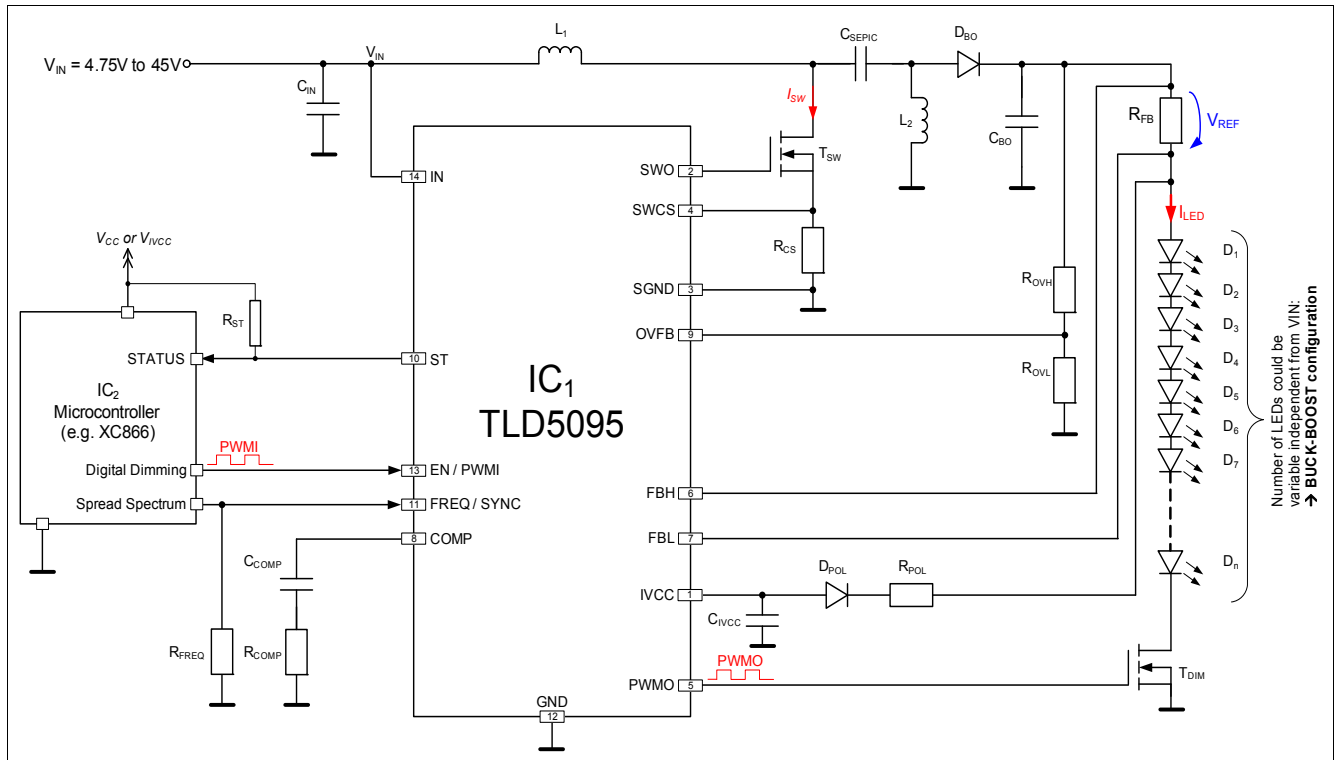
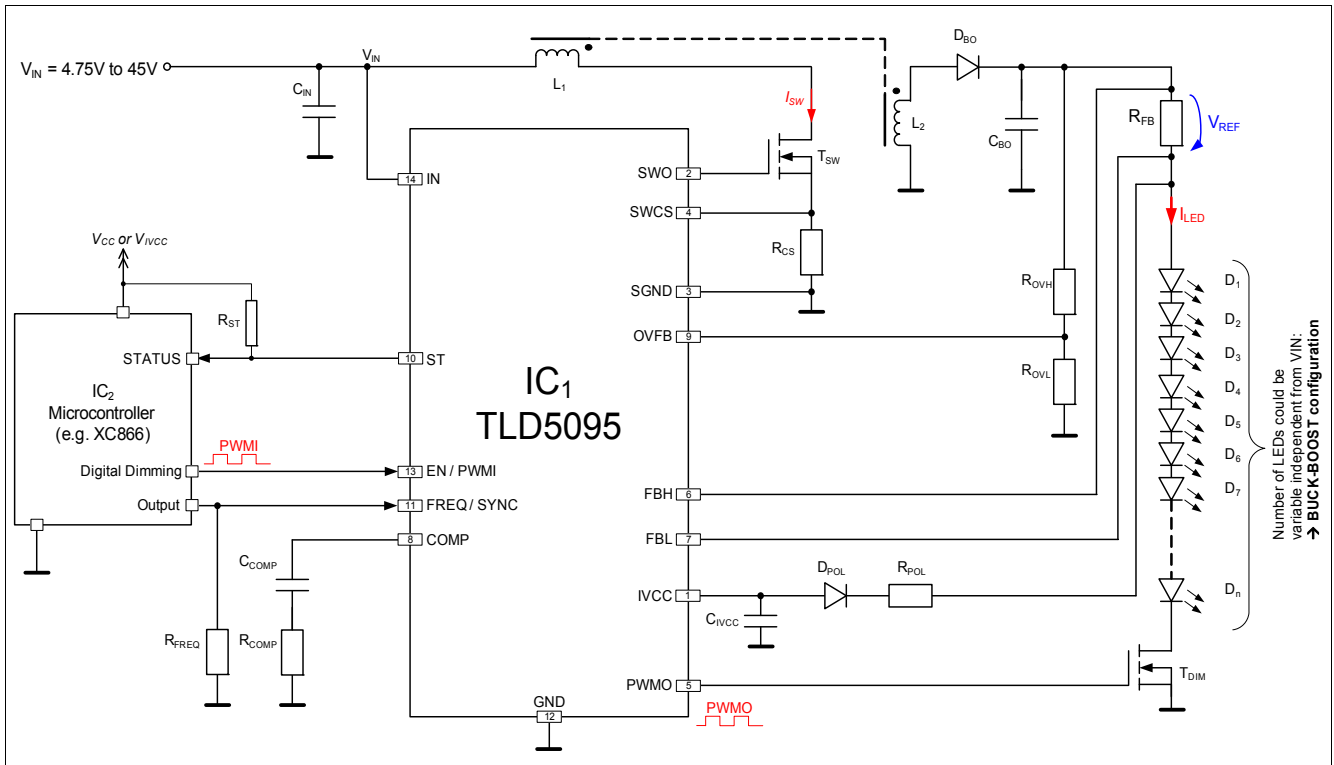

Figure 17 SEPIC Application Circuit (Buck-Boost configuration)

| Reference Designator                 | Value                             | Manufacturer | Part Number    | Type       | Quantity |
|--------------------------------------|-----------------------------------|--------------|----------------|------------|----------|
| D <sub>1</sub> - n                   | White                             | Osram        | LUW H9GP       | LED        | variable |
| D <sub>BO</sub>                      | Schottky, 3 A, 100 V <sub>R</sub> | Vishay       | SS3H10         | Diode      | 1        |
| D <sub>POL</sub>                     | 80V Diode                         | Infineon     | BAS 1603W      | Diode      | 1        |
| C <sub>SEPIC</sub>                   | 3.3 uF, 20V                       | EPCOS        | X7R, Low ESR   | Capacitor  | 1        |
| C <sub>IN</sub> , C <sub>BO</sub>    | 100 uF, 50V                       | Panasonic    | EEEFK1H101GP   | Capacitor  | 2        |
| C <sub>COMP</sub>                    | 10 nF                             | EPCOS        | X7R            | Capacitor  | 1        |
| C <sub>IVCC</sub>                    | 1uF , 6.3V                        | EPCOS        | X7R            | Capacitor  | 1        |
| IC <sub>1</sub>                      | --                                | Infineon     | TLD 5095       | IC         | 1        |
| IC <sub>2</sub>                      | --                                | Infineon     | XC866          | IC         | 1        |
| L <sub>1</sub> , L <sub>2</sub>      | 47 uH                             | Coilcraft    | MSS1278T-473ML | Inductor   | 2        |
|                                      | alternativ: 22uH coupled inductor | Coilcraft    | MSD1278-223MLD | Inductor   | 1        |
| R <sub>COMP</sub> , R <sub>POL</sub> | 10 kΩ, 1%                         | Panasonic    | ERJ3EKF 1002V  | Resistor   | 2        |
| R <sub>FB</sub>                      | 820 mΩ, 1%                        | Panasonic    | ERJ14BQFR82U   | Resistor   | 1        |
| R <sub>FREQ</sub> , R <sub>ST</sub>  | 20 kΩ, 1%                         | Panasonic    | ERJ3EKF 2002V  | Resistor   | 2        |
| R <sub>OVH</sub>                     | 33.2 kΩ, 1%                       | Panasonic    | ERJ3EKF 3322V  | Resistor   | 1        |
| R <sub>OVL</sub>                     | 1 kΩ, 1%                          | Panasonic    | ERJ3EKF 1001V  | Resistor   | 1        |
| R <sub>CS</sub>                      | 50 mΩ, 1%                         | Panasonic    | ERJB 1CFR05U   | Resistor   | 1        |
| T <sub>DIM</sub> , T <sub>SW</sub>   | Dual N-ch enh. (60V, 20A)         | Infineon     | IPG20N06S4L-26 | Transistor | 1        |
|                                      | alternativ: 100V N-ch, 35A        | Infineon     | IPD35N10S3L-26 | Transistor | 2        |
|                                      | alternativ: 60V N-ch, 2.6A        | Infineon     | BSP 318S       | Transistor | 2        |

Figure 18 Bill of Materials for SEPIC Application Circuit

**Figure 19 Flyback Application Circuit (Buck-Boost configuration)**

| Reference Designator | Value                             | Manufacturer   | Part Number          | Type       | Quantity |
|----------------------|-----------------------------------|----------------|----------------------|------------|----------|
| $D_1 - n$            | White                             | Osram          | LUW H9GP             | LED        | variable |
| $D_{BO}$             | Schottky, 3 A, 100 $V_R$          | Vishay         | SS3H10               | Diode      | 1        |
| $C_{BO}$             | 3.3 $\mu\text{F}$ , 50V (100V)    | EPCOS          | X7R, Low ESR         | Capacitor  | 1        |
| $C_{IN}$             | 100 $\mu\text{F}$ , 50V           | Panasonic      | EEEFK1H101GP         | Capacitor  | 1        |
| $C_{COMP}$           | 47 nF                             | EPCOS          | X7R                  | Capacitor  | 1        |
| $C_{IVCC}$           | 1 $\mu\text{F}$ , 6.3V            | EPCOS          | X7R                  | Capacitor  | 1        |
| $IC_1$               | --                                | Infineon       | TLD5095              | IC         | 1        |
| $IC_2$               | --                                | Infineon       | XC866                | IC         | 1        |
| $L_1, L_2$           | 1 $\mu\text{H}$ / 9 $\mu\text{H}$ | EPCOS          | Transformer EHP 16   | Inductor   | 1        |
| $R_{COMP}, R_{POL}$  | 10 k $\Omega$ , 1%                | Panasonic      | ERJ3EKF 1002V        | Resistor   | 2        |
| $D_{POL}$            | 80 V Diode                        | Infineon       | BAS 1603W            | Diode      | 1        |
| $R_{FB}$             | 820 m $\Omega$ , 1%               | Isabellenhütte | SMS – Power Resistor | Resistor   | 1        |
| $R_{FREQ}, R_{ST}$   | 10 k $\Omega$ , 1%                | Panasonic      | ERJ3EKF 1002V        | Resistor   | 2        |
| $R_{OVH}$            | 56.2 k $\Omega$ , 1%              | Panasonic      | ERJ3EKF 5622V        | Resistor   | 1        |
| $R_{OVL}$            | 1.24 k $\Omega$ , 1%              | Panasonic      | ERJ3EKF 1241V        | Resistor   | 1        |
| $R_{CS}$             | 5 m $\Omega$ , 1%                 | Isabellenhütte | SMS - Power Resistor | Resistor   | 1        |
| $T_{DIM}, T_{SW}$    | Dual N-ch enh. (60V, 20A)         | Infineon       | IPG20N06S4L-26       | Transistor | 1        |
|                      | alternativ: 100V N-ch, 35A        | Infineon       | IPG20N10S4L-22       | Transistor | 2        |
|                      | alternativ: 60V N-ch, 2.6A        | Infineon       | BSP318S              | Transistor | 2        |

**Figure 20 Bill of Materials for Flyback Application Circuit**

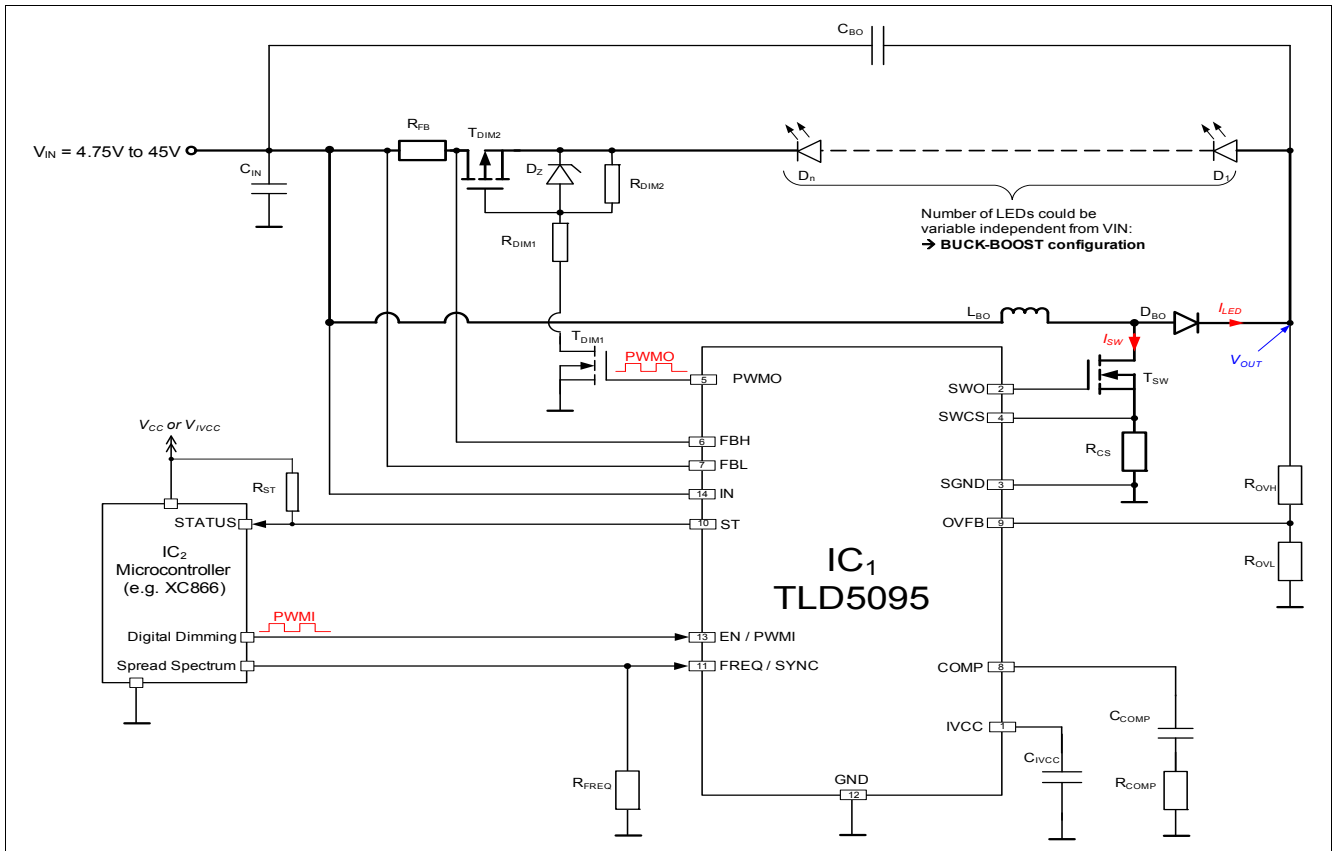
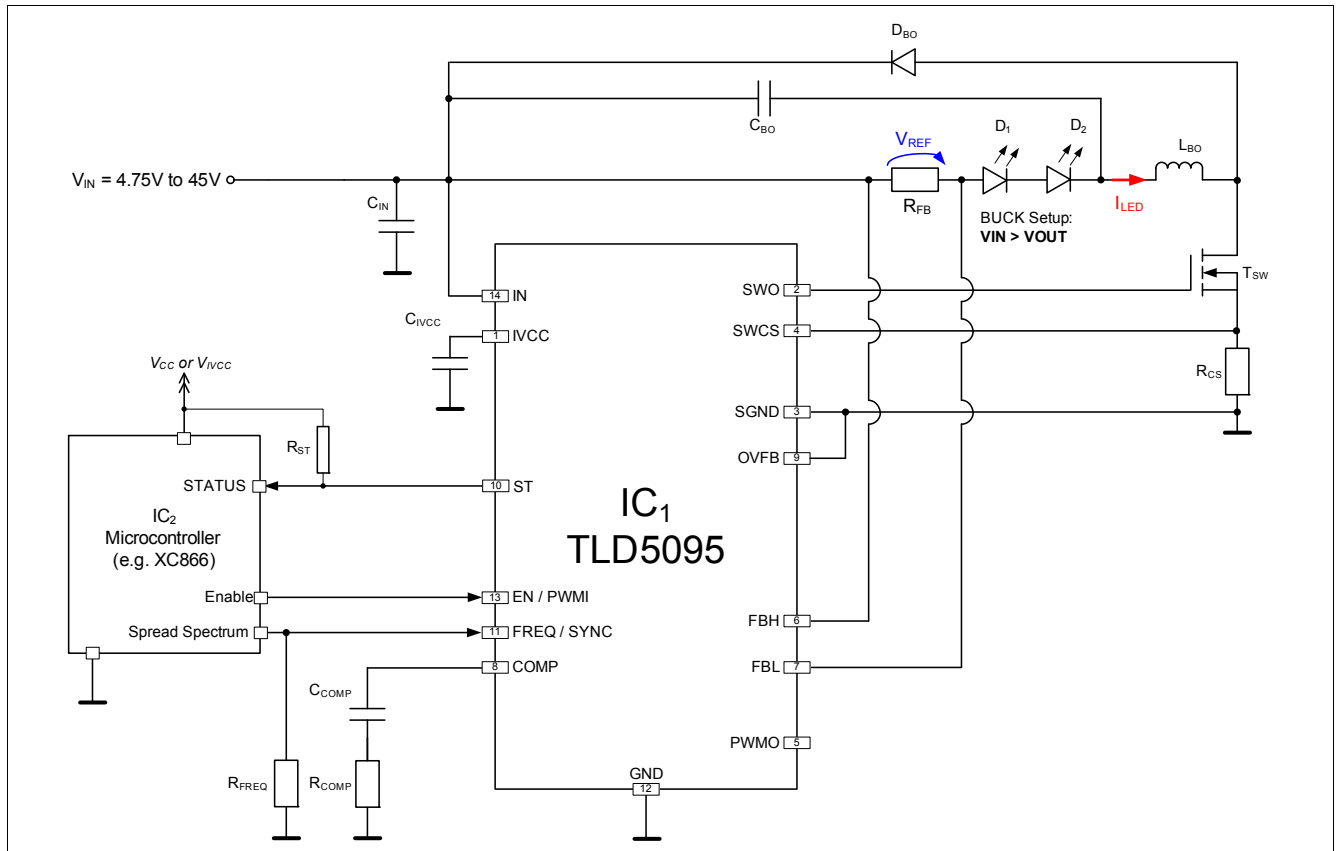

Figure 21 Boost to Battery Application Circuit - B2B (Buck-Boost configuration)

| Reference Designator                                      | Value                                    | Manufacturer | Part Number           | Type       | Quantity |
|---|--|--------------|-----------------------|------------|----------|
| D <sub>1-n</sub>  | White                                    | Osram        | LUW H9GP              | Diode      | variable |
| D <sub>BO</sub>   | Schottky, 3 A, 100 V <sub>R</sub>        | Vishay       | SS3H10                | Diode      | 1        |
| D <sub>Z</sub>  | 5V                                       | Vishay       | Zener                 | Diode      | 1        |
| C <sub>BO</sub>   | 100 uF, 80V                              | Panasonic    | EEVFK1K101Q           | Capacitor  | 1        |
| C <sub>IN</sub>   | 100 uF, 50V                              | Panasonic    | EEEFK1H101GP          | Capacitor  | 1        |
| C <sub>COMP</sub>   | 10 nF                                    | EPCOS        | X7R                   | Capacitor  | 1        |
| C <sub>IVCC</sub>   | 1 uF, 6.3V                               | EPCOS        | MLCC CCNPZC105KBW X7R | Capacitor  | 1        |
| IC <sub>1</sub>   | --                                       | Infineon     | TLD5095               | IC         | 1        |
| IC <sub>2</sub>   | --                                       | Infineon     | XC866                 | IC         | 1        |
| L <sub>BO</sub>   | 100 uH                                   | Coilcraft    | MSS1278T-104ML_       | Inductor   | 1        |
| R <sub>COMP</sub> , R <sub>DIM1</sub> , R <sub>DIM2</sub> | 10 kΩ, 1%                                | Panasonic    | ERJ3EKF 1002V         | Resistor   | 3        |
| R <sub>FB</sub>   | 820 mΩ, 1%                               | Panasonic    | ERJ14BQFR82U          | Resistor   | 1        |
| R <sub>FREQ</sub> , R <sub>ST</sub>                       | 20 kΩ, 1%                                | Panasonic    | ERJ3EKF 2002V         | Resistor   | 2        |
| R <sub>OVH</sub>  | 33.2 kΩ, 1%                              | Panasonic    | ERJP06F5102V          | Resistor   | 1        |
| R <sub>OVL</sub>  | 1 kΩ, 1%                                 | Panasonic    | ERJ3EKF 1001V         | Resistor   | 1        |
| R <sub>CS</sub>   | 50 mΩ, 1%                                | Panasonic    | ERJB1CFR05U           | Resistor   | 1        |
| T <sub>DIM1</sub> , T <sub>DIM2</sub>                     | 60V Dual N-ch (3.1A) and P-ch. enh. (2A) | Infineon     | BSO615CG              | Transistor | 1        |
|   | alternativ: 100V N-ch (0.37A),           | Infineon     | BSP 123               | Transistor | 1        |
|   | alternativ: 60V P-ch (1.9A)              | Infineon     | BSP 171P              | Transistor | 1        |
| T <sub>SW</sub>   | N-ch, OptiMOS-T2 100V, 35A               | Infineon     | IPD35N10S3L-26        | Transistor | 1        |
|   | alternativ: 60V N-ch, 30A                | Infineon     | IPD30N06S4L-23        | Transistor | 1        |
|   | alternativ: 60V N-ch, 2.6A               | Infineon     | BSP318S               | Transistor | 1        |

Figure 22 Bill of Materials for B2B Application Circuit

**Figure 23 Buck Application Circuit**

| Reference Designator                | Value                             | Manufacturer   | Part Number           | Type       | Quantity |
|-------------------------------------|-----------------------------------|----------------|-----------------------|------------|----------|
| D <sub>1-2</sub>                    | White                             | Osram          | LE UW Q9WP            | LED        | 2        |
| D <sub>BO</sub>                     | Schottky, 3 A, 100 V <sub>R</sub> | Vishay         | SS3H10                | Diode      | 1        |
| C <sub>BO</sub>                     | 4.7 uF, 50V                       | EPCOS          | X7R                   | Capacitor  | 1        |
| C <sub>IN</sub>                     | 100 uF, 50V                       | Panasonic      | EEEFK1H101GP          | Capacitor  | 1        |
| C <sub>COMP</sub>                   | 47 nF                             | EPCOS          | X7R                   | Capacitor  | 1        |
| C <sub>IVCC</sub>                   | 1 uF, 6.3V                        | EPCOS          | MLCC CCNPZC105KBW X7R | Capacitor  | 1        |
| IC <sub>1</sub>                     | --                                | Infineon       | TLD5095               | IC         | 1        |
| IC <sub>2</sub>                     | --                                | Infineon       | XC866                 | IC         | 1        |
| L <sub>1</sub>                      | 22 µH                             | Coilcraft      | MSS1278T              | Inductor   | 1        |
| R <sub>COMP</sub>                   | 10 kΩ, 1%                         | Panasonic      | ERJ3EKF1002V          | Resistor   | 1        |
| R <sub>FB</sub>                     | 820 mΩ, 1%                        | Isabellenhütte | SMS – Power Resistor  | Resistor   | 1        |
| R <sub>FREQ</sub> , R <sub>ST</sub> | 20 kΩ, 1%                         | Panasonic      | ERJ3EKF2002V          | Resistor   | 2        |
| R <sub>CS</sub>                     | 50 mΩ, 1%                         | Isabellenhütte | SMS - Power Resistor  | Resistor   | 1        |
| T <sub>SW</sub>                     | 100V, N-ch, 35A                   | Infineon       | IPG20N10S4L-22        | Transistor | 1        |
|                                     | alternativ : 60V N-ch, 30A        | Infineon       | IPD30N06S4L-23        | Transistor | 1        |

**Figure 24 Bill of Materials for Buck Application Circuit**

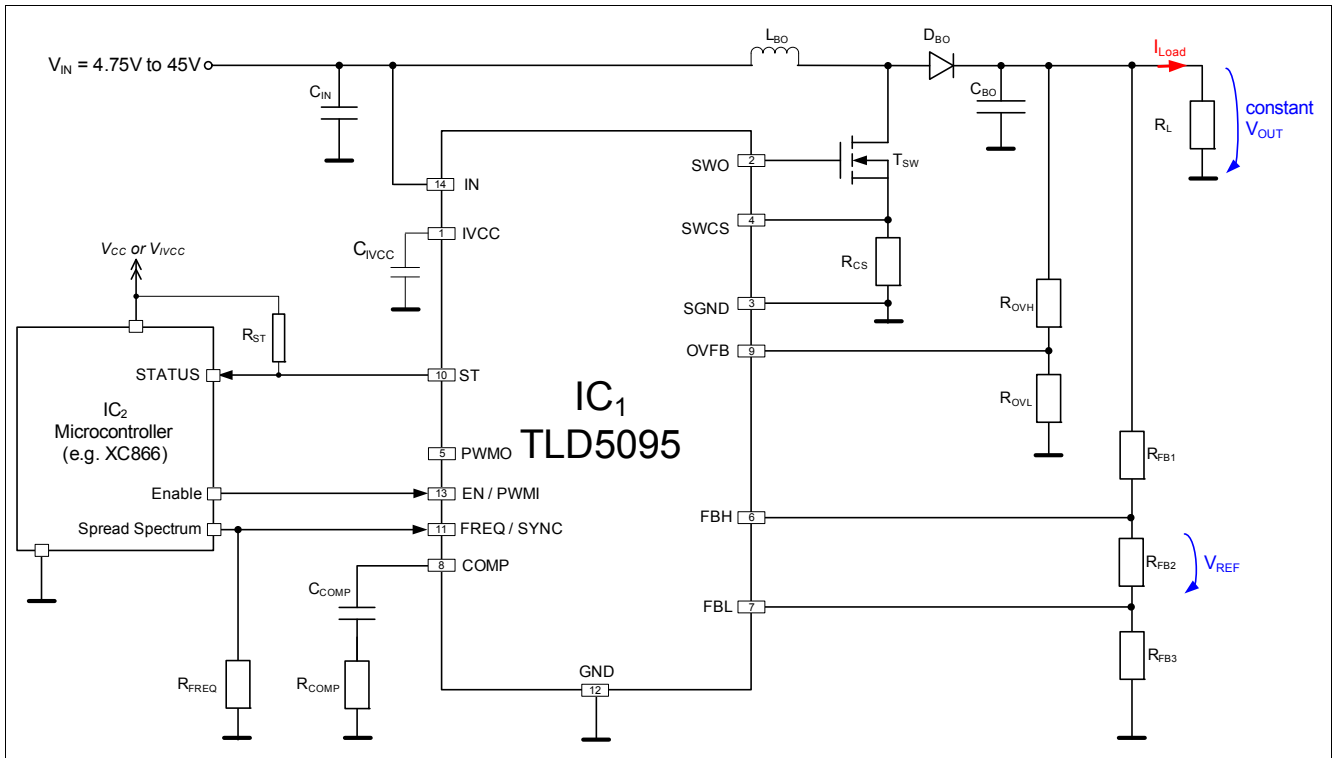

Figure 25 Boost Voltage Application Circuit

| Reference Designator                | Value                             | Manufacturer | Part Number     | Type       | Quantity |
|-------------------------------------|-----------------------------------|--------------|-----------------|------------|----------|
| D <sub>BO</sub>                     | Schottky, 3 A, 100 V <sub>R</sub> | Vishay       | SS3H10          | Diode      | 1        |
| C <sub>BO</sub>                     | 100 uF, 80V                       | Panasonic    | EEVFK1K101Q     | Capacitor  | 1        |
| C <sub>IN</sub>                     | 100 uF, 50V                       | Panasonic    | EEEFK1H101GP    | Capacitor  | 1        |
| C <sub>COMP</sub>                   | 10 nF, 16V                        | EPCOS        | X7R             | Capacitor  | 1        |
| C <sub>IVCC</sub>                   | 1 uF, 6.3V                        | Panasonic    | X7R             | Capacitor  | 1        |
| IC <sub>1</sub>                     | --                                | Infineon     | TLD5095         | IC         | 1        |
| IC <sub>2</sub>                     | --                                | Infineon     | XC866           | IC         | 1        |
| L <sub>BO</sub>                     | 100 uH                            | Coilcraft    | MSS1278T-104ML_ | Inductor   | 1        |
| R <sub>COMP</sub>                   | 10 kohms, 1%                      | Panasonic    | ERJ3EKF1002V    | Resistor   | 1        |
| R <sub>FB1</sub> , R <sub>FB3</sub> | 51 kohms, 1%                      | Panasonic    | ERJ3EKF5102V    | Resistor   | 1        |
| R <sub>FB2</sub>                    | 1 kohms, 1%                       | Panasonic    | ERJ3EKF1001V    | Resistor   | 1        |
| R <sub>FREQ</sub> , R <sub>ST</sub> | 20 kohms, 1%                      | Panasonic    | ERJ3EKF2002V    | Resistor   | 2        |
| R <sub>OVH</sub>                    | 33.2 kohms, 1%                    | Panasonic    | ERJ3EKF3322V    | Resistor   | 1        |
| R <sub>OVL</sub>                    | 1 kohms, 1%                       | Panasonic    | ERJ3EKF1001V    | Resistor   | 1        |
| R <sub>CS</sub>                     | 50 mohms, 1%                      | Panasonic    | ERJB1CFR05U     | Resistor   | 1        |
| T <sub>SW</sub>                     | N-ch, OptiMOS-T2 100V             | Infineon     | IPD35N10S3L-26  | Transistor | 1        |

Figure 26 Bill of Materials for Boost Voltage Application Circuit

Note: The application drawings and corresponding bill of materials are simplified examples. Optimization of the external components must be done accordingly to specific application requirements.



**10.1 Further Application Information**

- For further information you may contact <http://www.infineon.com/>
- Application Note: TLD509x DC-DC Multitopology Controller IC “Dimensioning and Stability Guideline - Theory and Practice”

## 11 Revision History

| Revision | Date       | Changes   |
|----------|------------|---|
| 1.0      | 2009-11-30 | Initial Datasheet   |
| 1.1      | 2009-12-16 | <ul style="list-style-type: none"> <li>• Cover sheet updated</li> <li>• Package naming updated</li> <li>• <b>Figure 2</b> updated</li> <li>• Exposed Pad pin description updated</li> </ul>   |
| 1.2      | 2012-04-05 | <b>Page 3:</b> RoHS Logo update<br><b>Page 3:</b> Topology update<br>Application Information chapter update   |
| 1.3      | 2013-08-06 | <b>Page 18:</b> Update Test Condition of parameter <b>8.2.1</b>   |
| 1.4      | 2014-03-10 | Editorial changes<br><b>Page 11:</b> Update <b>Figure 5</b><br><b>Page 17:</b> Update verbal description <b>Chapter 8.1</b> (paragraph 1)<br><b>Page 28, Page 29:</b> Update BOM <b>Figure 24</b> and <b>Figure 26</b> in <b>Chapter 10.1</b> |

## 12 Package Outlines

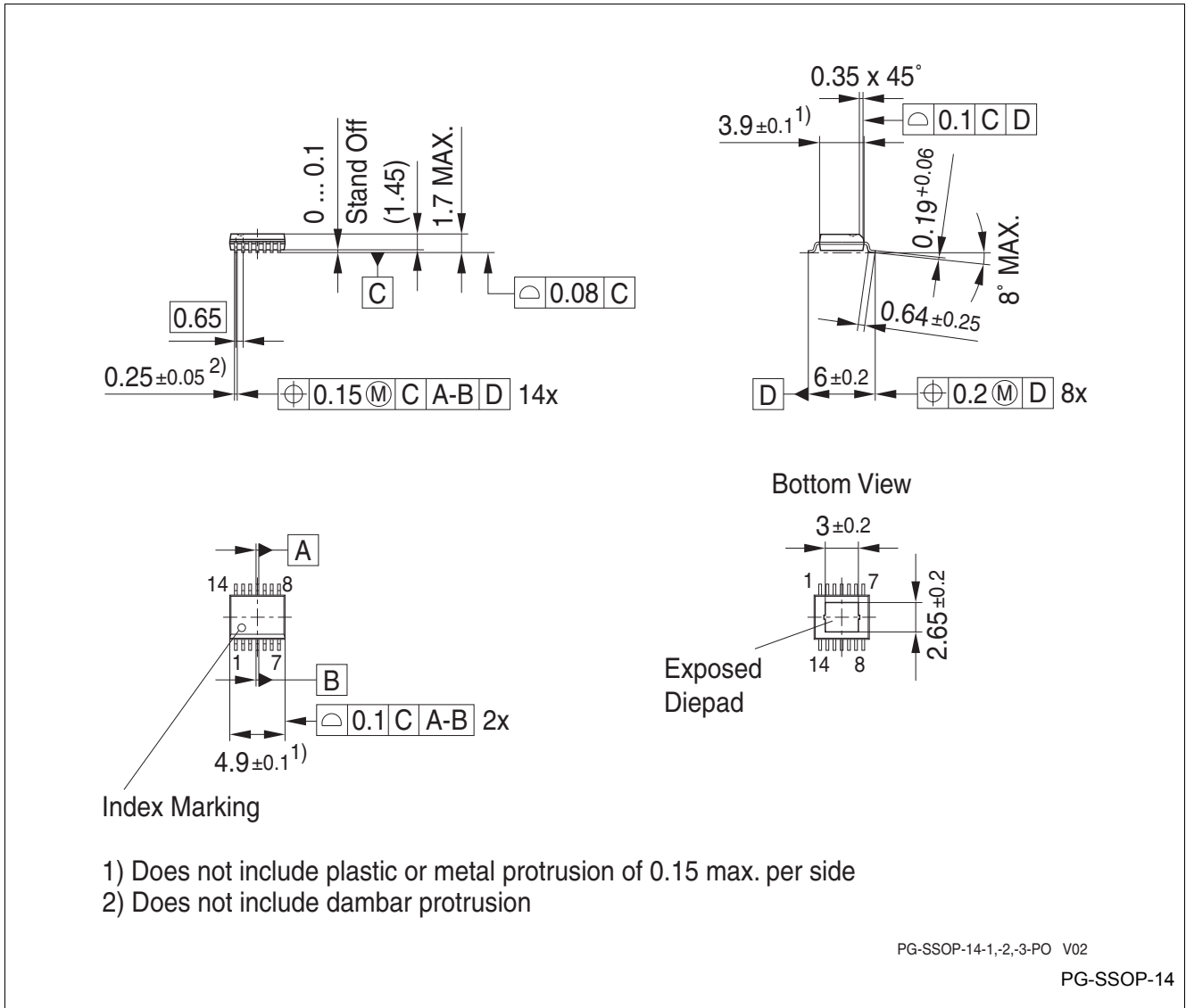

Figure 27 PG-SSOP-14

### Green Product (RoHS compliant)

To meet the world-wide customer requirements for environmentally friendly products and to be compliant with government regulations the device is available as a green product. Green products are RoHS-Compliant (i.e Pb-free finish on leads and suitable for Pb-free soldering according to IPC/JEDEC J-STD-020).

For further package information, please visit our website:  
<http://www.infineon.com/packages>.

Dimensions in mm

**Edition 2014-03-10**

**Published by  
Infineon Technologies AG  
81726 Munich, Germany**

**© 2014 Infineon Technologies AG  
All Rights Reserved.**

### **Legal Disclaimer**

The information given in this document shall in no event be regarded as a guarantee of conditions or characteristics. With respect to any examples or hints given herein, any typical values stated herein and/or any information regarding the application of the device, Infineon Technologies hereby disclaims any and all warranties and liabilities of any kind, including without limitation, warranties of non-infringement of intellectual property rights of any third party.

### **Information**

For further information on technology, delivery terms and conditions and prices, please contact the nearest Infineon Technologies Office ([www.infineon.com](http://www.infineon.com)).

### **Warnings**

Due to technical requirements, components may contain dangerous substances. For information on the types in question, please contact the nearest Infineon Technologies Office.

Infineon Technologies components may be used in life-support devices or systems only with the express written approval of Infineon Technologies, if a failure of such components can reasonably be expected to cause the failure of that life-support device or system or to affect the safety or effectiveness of that device or system. Life support devices or systems are intended to be implanted in the human body or to support and/or maintain and sustain and/or protect human life. If they fail, it is reasonable to assume that the health of the user or other persons may be endangered.

# Mouser Electronics

Authorized Distributor

Click to View Pricing, Inventory, Delivery & Lifecycle Information:

[Infineon:](#)

[TLD5095EL](#)

Компания «Life Electronics» занимается поставками электронных компонентов импортного и отечественного производства от производителей и со складов крупных дистрибьюторов Европы, Америки и Азии.

С конца 2013 года компания активно расширяет линейку поставок компонентов по направлению коаксиальный кабель, кварцевые генераторы и конденсаторы (керамические, пленочные, электролитические), за счёт заключения дистрибьюторских договоров

Мы предлагаем:

- Конкурентоспособные цены и скидки постоянным клиентам.
- Специальные условия для постоянных клиентов.
- Подбор аналогов.
- Поставку компонентов в любых объемах, удовлетворяющих вашим потребностям.
- Приемлемые сроки поставки, возможна ускоренная поставка.
- Доставку товара в любую точку России и стран СНГ.
- Комплексную поставку.
- Работу по проектам и поставку образцов.
- Формирование склада под заказчика.
- Сертификаты соответствия на поставляемую продукцию (по желанию клиента).
- Тестирование поставляемой продукции.
- Поставку компонентов, требующих военную и космическую приемку.
- Входной контроль качества.
- Наличие сертификата ISO.

В составе нашей компании организован Конструкторский отдел, призванный помогать разработчикам, и инженерам.

Конструкторский отдел помогает осуществить:

- Регистрацию проекта у производителя компонентов.
- Техническую поддержку проекта.
- Защиту от снятия компонента с производства.
- Оценку стоимости проекта по компонентам.
- Изготовление тестовой платы монтаж и пусконаладочные работы.



Тел: +7 (812) 336 43 04 (многоканальный)  
Email: [org@lifeelectronics.ru](mailto:org@lifeelectronics.ru)