

A Unit of Teledyne Electronics and Communications

## CENTIGRID® ESTABLISHED RELIABILITY RELAY DPDT SENSITIVE CMOS COMPATIBLE

# SERIES 136C

| SERIES DESIGNATION | RELAY TYPE  |
|--------------------|---|
| 136C               | DPDT sensitive relay with internal power MOSFET driver, Zener diode gate protection, and diode coil suppression |

### INTERNAL CONSTRUCTION

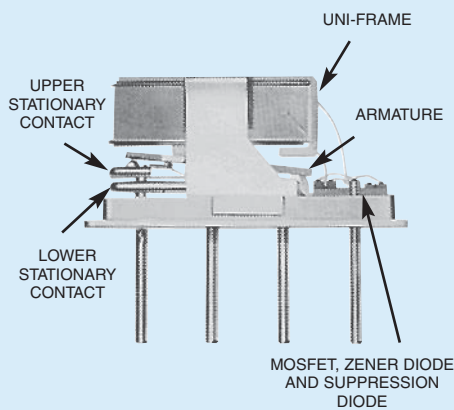

### DESCRIPTION

The sensitive 136C Centigrd® relay is an ultraminiature, hermetically sealed, armature relay capable of being directly driven by most IC logic families. Its low profile height and .100" grid spaced terminals, which precludes the need for spreader pads, make it ideal for applications where extreme packaging density and/or close PC board spacing are required.

The basic concept and internal mechanical structure are similar to the 114 DPDT relay. The following unique construction features and manufacturing techniques provide overall high reliability and excellent resistance to environmental extremes:

- All welded construction.
- Unique uni-frame design providing high magnetic efficiency and mechanical rigidity.
- High force/mass ratios for resistance to shock and vibration.
- Advanced cleaning techniques provide maximum assurance of internal cleanliness.
- Precious metal alloy contact material with gold plating assures excellent high current and dry circuit switching capabilities.

The sensitive 136C Centigrd® relay has a high resistance coil, thus requiring extremely low operating power (200 mW, typical). The advantages of reduced heat dissipation and power supply demands are a plus.

By virtue of its inherently low intercontact capacitance and contact circuit losses, the 136C relay has proven to be an excellent ultraminiature RF switch for frequency ranges well into the UHF spectrum. A typical RF application for the Centigrd® relay is in handheld radio transceivers, wherein the combined features of good RF performance, small size, low coil power dissipation and high reliability make it a preferred method of Transmit- Receive switching (see Figure 1).

The sensitive Series 136C utilizes an internal silicon diode for coil suppression, a Zener diode to protect the MOSFET gate input, and an N-channel enhancement-mode MOSFET chip that enables direct relay interfacing with most microprocessor and IC logic families (CMOS, TTL and MOS).

### ENVIRONMENTAL AND PHYSICAL SPECIFICATIONS

|                                      |                              |
|--------------------------------------|------------------------------|
| <b>Temperature</b><br>(Ambient)      | -65°C to +125°C              |
| <b>Vibration</b><br>(General Note 1) | 30 g's to 3000 Hz            |
| <b>Shock</b><br>(General Note 1)     | 75 g's,<br>6 msec, half-sine |
| <b>Acceleration</b>                  | 50 g's                       |
| <b>Enclosure</b>                     | Hermetically sealed          |
| <b>Weight</b>                        | 0.18 oz. (5.11g) max.        |

**SERIES 136C**

**GENERAL ELECTRICAL SPECIFICATIONS (-65°C to +125°C unless otherwise noted) (Notes 2 & 3)**

|   |  |                           |
|---|--|---------------------------|
| <b>Contact Arrangement</b>  | 2 Form C (DPDT)  |                           |
| <b>Rated Duty</b>   | Continuous   |                           |
| <b>Contact Resistance</b>   | 0.1 ohm max. before life; 0.2 ohm max. after life at 1A/28Vdc (measured 1/8" from header)  |                           |
| <b>Contact Load Ratings (DC)</b><br>(See Fig. 2 for other DC resistive voltage/current ratings) | Resistive: 1 Amp/28Vdc<br>Inductive: 200 mA/28Vdc (320 mH)<br>Lamp: 100 mA/28Vdc<br>Low Level: 10 to 50 µA/10 to 50mV                                    |                           |
| <b>Contact Load Ratings (AC)</b>  | Resistive: 250 mA/115Vac, 60 and 400 Hz (Case not grounded)<br>100 mA/115Vac, 60 and 400 Hz (Case grounded)  |                           |
| <b>Contact Life Ratings</b>   | 10,000,000 cycles (typical) at low level<br>1,000,000 cycles (typical) at 0.5A/28Vdc resistive<br>100,000 cycles min. at all other loads specified above |                           |
| <b>Contact Overload Rating</b>  | 2A/28Vdc Resistive (100 cycles min.)   |                           |
| <b>Contact Carry Rating</b>   | Contact factory  |                           |
| <b>Operate Time</b>   | 4.0 msec max. at nominal rated coil voltage  |                           |
| <b>Release Time</b>   | 7.5 msec max.  |                           |
| <b>Contact Bounce</b>   | 1.5 msec max.  |                           |
| <b>Intercontact Capacitance</b>   | 0.4 pf typical   |                           |
| <b>Insulation Resistance</b>  | 10,000 megohms min. between mutually isolated terminals  |                           |
| <b>Dielectric Strength</b>  | Atmospheric pressure: 500 Vrms/60Hz  | 70,000 ft.: 125 Vrms/60Hz |
| <b>Negative Coil Transient (Vdc)</b>  | 1.0 max  |                           |
| <b>Diode P.I.V. (Vdc)</b>   | 100 min.   |                           |
| <b>Zener Voltage (Vdc)</b>  | 17 min. to 23 max.   |                           |
| <b>Zener Leakage Current (µA @ 15.2 Vdc)</b>  | 2.5 max  |                           |
| <b>Power FET Characteristics</b><br>-65°C to +125°C   | <b>Gate Voltage to Turn Off (Vdc, Max.)</b>  | 0.5                       |
|   | <b>Gate Voltage to Turn On (Vdc, Max.)</b>   | 3.8 (Note 4)              |
|   | <b>Drain-Source Voltage (Vdc, Max.)</b>  | 55                        |

ESTABLISHED RELIABILITY

**DETAILED ELECTRICAL SPECIFICATIONS (-65°C to +125°C unless otherwise noted) (Note 3)**

|   | BASE PART NUMBERS<br>(See Note 8 for full P/N example) | ➔      |        |        |         |         |         |
|---|--|--------|--------|--------|---------|---------|---------|
|   |  | 136C-5 | 136C-6 | 136C-9 | 136C-12 | 136C-18 | 136C-26 |
| <b>Coil Voltage (Vdc)</b>                               | Nom.   | 5.0    | 6.0    | 9.0    | 12.0    | 18.0    | 26.5    |
|   | Max.   | 5.6    | 8.0    | 12.0   | 16.0    | 24.0    | 32.0    |
| <b>Coil Current (mAdc @25°C)</b>                        | Max.   | 56.0   | 33.0   | 26.4   | 17.7    | 13.8    | 10.2    |
|   | Min.   | 43.0   | 27.0   | 17.8   | 11.3    | 8.4     | 5.8     |
| <b>Nominal Coil Operating Power @ 25°C (Milliwatts)</b> |  | 250    | 180    | 203    | 180     | 203     | 219     |
| <b>Pick-up Voltage (Vdc)</b> (Note 4)                   | Max.   | 4.0    | 4.9    | 7.3    | 9.8     | 14.6    | 19.5    |
| <b>Drop-out Voltage (Vdc)</b><br>(Note 4)               | Min.   | 0.13   | 0.18   | 0.27   | 0.36    | 0.54    | 0.72    |
|   | Max.   | 2.3    | 3.2    | 4.9    | 6.5     | 9.8     | 13.0    |

**PERFORMANCE CURVES (NOTE 2)**

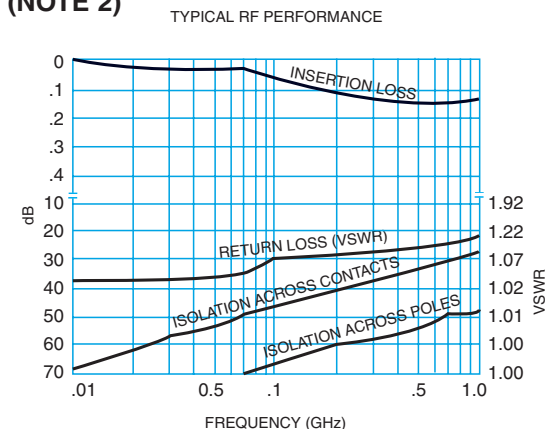

**FIGURE 1**

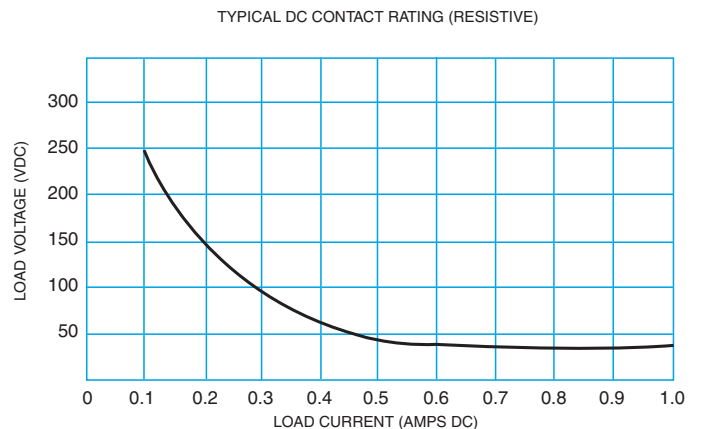

**FIGURE 2**

**OUTLINE DIMENSIONS**

**CASE DETAIL**

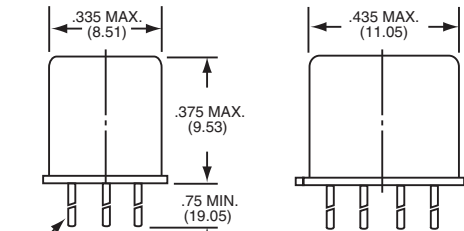

9 LEADS DIMENSIONS ARE SHOWN IN INCHES (MILLIMETERS)

**TERMINAL LOCATIONS**

(Viewed from Terminals; Numbers for Reference Only)

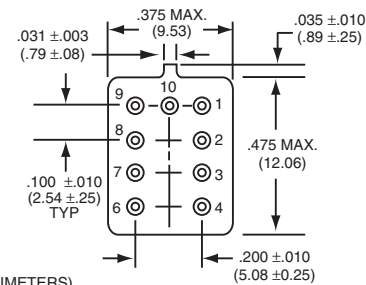

**SCHEMATIC DIAGRAM**

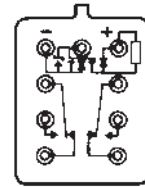

PIN 1: + SUPPLY  
PIN 9: - SUPPLY  
PIN 10: GATE

SCHEMATIC IS VIEWED FROM TERMINALS

**GENERAL NOTES**

1. Relay contacts will exhibit no chatter in excess of 10  $\mu$ sec or transfer in excess of 1  $\mu$ sec.
2. "Typical" characteristics are based on available data and are best estimates. No on-going verification tests are performed.
3. Unless otherwise specified, parameters are initial values.
4. Maximum rated gate voltage = 15 Vdc.
5. Unless otherwise specified, relays will be supplied with either gold plated or solder coated leads.
6. The slash and character appearing after the slash are not marked on the relay.
7. Screened HI-REL versions available. Contact factory.
- 8.

**TYPICAL CMOS INTERFACE CIRCUIT**

DC Logic Voltage Supply

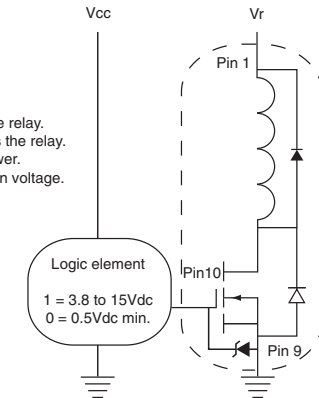

Notes:  
Logic 1 activates the relay.  
Logic 0 de-activates the relay.  
Vcc = logic bias power.  
Vr = coil energization voltage.

Teledyne Part Numbering System for  $T^2R^{\circledR}$  Established Reliability Relay

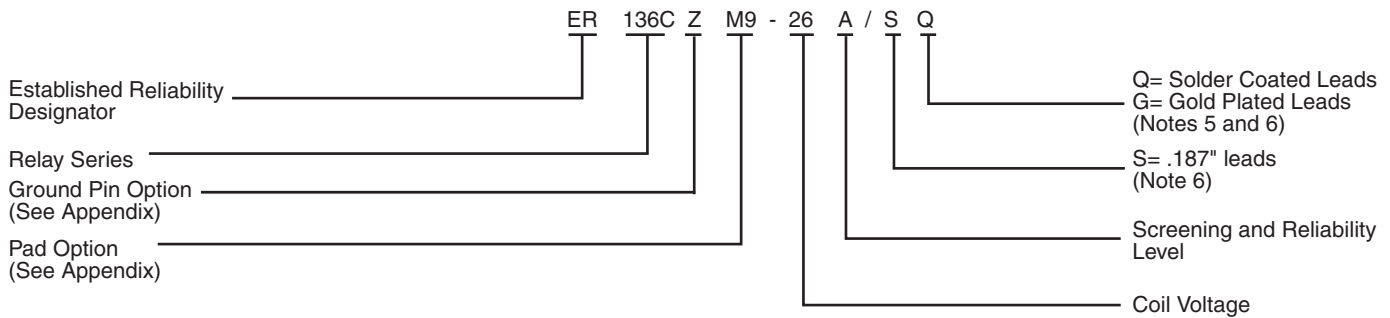

Teledyne Part Numbering System for Military Qualified (JAN) Relays

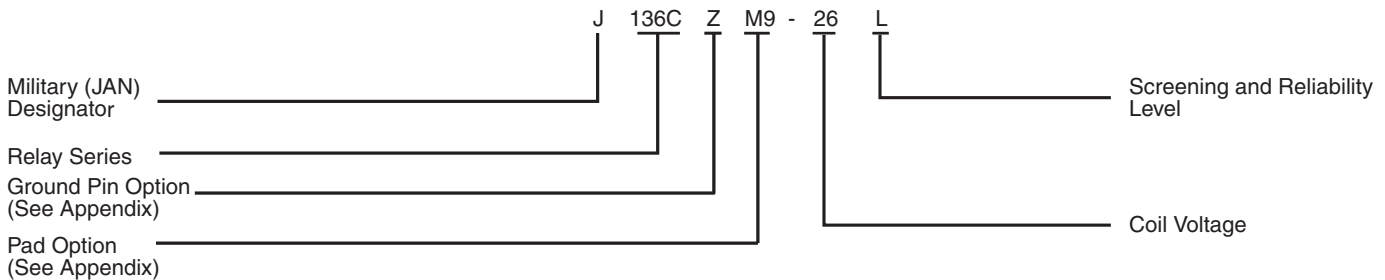

# Appendix A: Spacer Pads

| Pad designation and bottom view dimensions   | Height  | For use with the following:  | Dim. H Max.  |
|--|---|--|--------------|
|  <p style="text-align: center;">“M4” Pad for TO-5</p>         |    | ER411T<br>ER412, ER412D, ER412DD   | .295 (7.49)  |
|  |   | 712, 712D, 712TN,<br>RF300, RF310, RF320   | .300 (7.62)  |
|  |   | ER420, ER422D, ER420DD, 421,<br>ER421D, ER421DD, ER422, ER422D,<br>ER422DD, 722, 722D, RF341 | .305 (7.75)  |
|  |   | ER431T, ER432T,<br>ER432, ER432D, ER432DD  | .400 (10.16) |
|  |   | 732, 732D, 732TN, RF303, RF313,<br>RF323   | .410 (10.41) |
|  |   | RF312  | .350 (8.89)  |
|  <p style="text-align: center;">“M4” Pad for TO-5</p>         |    | ER411, ER411D, ER411DD   | .295 (7.49)  |
|  |   | ER431, ER431D, ER431DD   | .400 (10.16) |
|  |   | RF311  | .300 (7.62)  |
|  |   | RF331  | .410 (10.41) |
|  <p style="text-align: center;">“M4” Pad for Centigrid®</p> |  | 172, 172D  | .305 (7.75)  |
|  |   | ER114, ER114D, ER114DD,<br>J114, J114D, J114DD   | .300 (7.62)  |
|  |   | ER134, ER134D, ER134DD,<br>J134, J134D, J134DD   | .400 (10.16) |
|  |   | RF100  | .315 (8.00)  |
|  |   | RF103  | .420 (10.67) |
|  <p style="text-align: center;">“M9” Pad for Centigrid®</p> |  | 122C, A152   | .320 (8.13)  |
|  |   | ER116C, J116C  | .300 (7.62)  |
|  |   | ER136C, J136C  | .400 (10.16) |
|  |   | RF180  | .325 (8.25)  |
|  |   | A150   | .305 (7.75)  |

**Notes:**

1. Spacer pad material: Polyester film.
2. To specify an “M4” or “M9” spacer pad, refer to the mounting variants portion of the part numbering example in the applicable datasheet.
3. Dimensions are in inches (mm).
4. Unless otherwise specified, tolerance is  $\pm .010$  (.25).
5. Add 10 mΩ to the contact resistance show in the datasheet.
6. Add 0.01 oz. (0.25 g) to the weight of the relay assembly shown in the datasheet.

# Appendix A: Spreader Pads

| Pad designation and bottom view dimensions  | Height  | For use with the following:   | Dim. H Max.  |
|---|---|---|--------------|
|  <p>"M" Pad <u>5/</u> <u>6/</u> <u>9/</u></p>    |    | ER411T, J411T, ER412, ER412D<br>ER412DD, J412, J412D, J412DD<br>ER412T, J412T                                       | .388 (9.86)  |
|   |   | 712, 712D, 712TN  | .393 (9.99)  |
|   |   | ER431T, J431T, ER432, ER432D<br>ER432DD, J432, J432D, J432DD<br>ER432T, J432T                                       | .493 (12.52) |
|   |   | 732, 732D, 732TN  | .503 (12.78) |
|   |   | ER420, J420, ER420D, J420D<br>ER420DD, J420DD, ER421, J421<br>ER421D, J421D, ER421DD<br>J422D, ER422DD, J422DD, 722 | .398 (10.11) |
|  <p>"M2" Pad <u>7/</u> <u>8/</u></p>            |   | ER411T<br>ER412, ER412D, ER412DD<br>J412, J412D, J412DD   | .441 (11.20) |
|   |   | 712, 712D   | .451 (11.46) |
|   |   | ER421, ER421D, ER421DD<br>722, 732D   | .451 (11.46) |
|   |   | ER431T<br>ER432, ER432D, ER432DD  | .546 (13.87) |
|   |   | 732, 732D   | .556 (14.12) |
|  <p>"M3" Pad <u>5/</u> <u>6/</u> <u>9/</u></p> |  | ER411, ER411D, ER411DD<br>ER411TX<br>ER412X, ER412DX, ER412DDX<br>ER412TX   | .388 (9.86)  |
|   |   | 712X, 712DX, 712TNX   | .393 (9.99)  |
|   |   | ER420X, ER420DX, ER420DDX<br>ER421X, ER421DX, ER421DDX<br>ER422X, ER422DX<br>ER422DDX, 722X, 722DDX                 | .398 (10.11) |
|   |   | ER431, ER431D, ER431DD<br>ER431TX<br>ER432X, ER432DX, ER432DDX<br>ER432TX   | .493 (12.52) |
|   |   | 732X, 732DX, 732TNX   | .503 (12.78) |

## Notes:

1. Spreader pad material: Diallyl Phthalate.
2. To specify an "M", "M2" or "M3" spreader pad, refer to the mounting variants portion of the part number example in the applicable datasheet.
3. Dimensions are in inches (mm).
4. Unless otherwise specified, tolerance is  $\pm .010$ " (0.25).
- 5/. Add 25 m $\Omega$  to the contact resistance shown in the datasheet.
- 6/. Add .01 oz. (0.25 g) to the weight of the relay assembly shown in the datasheet.
- 7/. Add 50 m $\Omega$  to the contact resistance shown in the datasheet.
- 8/. Add 0.025 oz (0.71 g) to the weight of the relay assembly shown in the datasheet.
- 9/. M3 pad to be used only when the relay has a center pin (e.g. ER411M3-12A, 722XM3-26.)

# Appendix A: Ground Pin Positions



### TO-5 Relays:

ER411T, ER412, ER412T, ER420, ER421, ER422,  
ER431T, ER432, ER432T, 712, 712TN, 400H, 400K,  
400V, RF300, RF303, RF341, RF312, RF310, RF313,  
RF320, RF323



### TO-5 Relays:

ER411, ER431, RF311, RF331



### Centigrad® Relays:

RF180, ER116C, 122C, ER136C

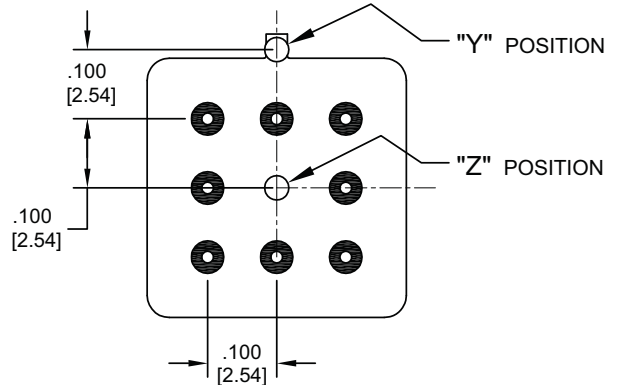

### Centigrad® Relays:

RF100, RF103, ER114, ER134, 172

- Indicates ground pin position
- Indicates glass insulated lead position
- ⊙ Indicates ground pin or lead position depending on relay type

### NOTES

1. Terminal views shown
2. Dimensions are in inches (mm)
3. Tolerances:  $\pm .010$  ( $\pm .25$ ) unless otherwise specified
4. Ground pin positions are within  $.015$  ( $0.38$ ) dia. of true position
5. Ground pin head dia.,  $0.035$  ( $0.89$ ) ref: height  $0.010$  ( $0.25$ ) ref.
6. Lead dia.  $0.017$  ( $0.43$ ) nom.

Компания «Life Electronics» занимается поставками электронных компонентов импортного и отечественного производства от производителей и со складов крупных дистрибьюторов Европы, Америки и Азии.

С конца 2013 года компания активно расширяет линейку поставок компонентов по направлению коаксиальный кабель, кварцевые генераторы и конденсаторы (керамические, пленочные, электролитические), за счёт заключения дистрибьюторских договоров

Мы предлагаем:

- Конкурентоспособные цены и скидки постоянным клиентам.
- Специальные условия для постоянных клиентов.
- Подбор аналогов.
- Поставку компонентов в любых объемах, удовлетворяющих вашим потребностям.
- Приемлемые сроки поставки, возможна ускоренная поставка.
- Доставку товара в любую точку России и стран СНГ.
- Комплексную поставку.
- Работу по проектам и поставку образцов.
- Формирование склада под заказчика.
- Сертификаты соответствия на поставляемую продукцию (по желанию клиента).
- Тестирование поставляемой продукции.
- Поставку компонентов, требующих военную и космическую приемку.
- Входной контроль качества.
- Наличие сертификата ISO.

В составе нашей компании организован Конструкторский отдел, призванный помогать разработчикам, и инженерам.

Конструкторский отдел помогает осуществить:

- Регистрацию проекта у производителя компонентов.
- Техническую поддержку проекта.
- Защиту от снятия компонента с производства.
- Оценку стоимости проекта по компонентам.
- Изготовление тестовой платы монтаж и пусконаладочные работы.



Тел: +7 (812) 336 43 04 (многоканальный)  
Email: [org@lifeelectronics.ru](mailto:org@lifeelectronics.ru)