

103-dB, 192-kHz, Stereo Audio ADC with 6:1 Input Mux

ADC Features

- ◆ Multi-bit Delta–Sigma Modulator
- ◆ 103 dB Dynamic Range
- ◆ -95 dB THD+N
- ◆ Stereo 6:1 Input Multiplexer
- ◆ Programmable Gain Amplifier (PGA)
 - ± 12 dB Gain, 0.5-dB Step Size
 - Zero-crossing, Click-free Transitions
- ◆ Stereo Microphone Inputs
 - +32 dB Gain Stage
 - Low-noise Bias Supply
- ◆ Up to 192 kHz Sampling Rates
- ◆ Selectable 24-bit, Left-justified or I²S Serial Audio Interface Formats

System Features

- ◆ Power-down Mode
- ◆ +5 V Analog Power Supply, Nominal
- ◆ +3.3 V Digital Power Supply, Nominal
- ◆ Direct Interface with 3.3 V to 5 V Logic Levels
- ◆ Pin Compatible with CS5345 (*See [Section 2](#) for details.)

General Description

The CS5346 integrates an analog multiplexer, programmable gain amplifier, and stereo audio analog-to-digital converter. The CS5346 performs stereo analog-to-digital (A/D) conversion of 24-bit serial values at sample rates up to 192 kHz.

A 6:1 stereo input multiplexer is included for selecting between line-level and microphone-level inputs. The microphone input path includes a +32 dB gain stage and a low-noise bias voltage supply. The PGA is available for line or microphone inputs and provides gain/attenuation of ± 12 dB in 0.5 dB steps.

The output of the PGA is followed by an advanced 5th-order, multi-bit delta-sigma modulator and digital filtering/decimation. Sampled data is transmitted by the serial audio interface at rates from 8 kHz to 192 kHz in either Slave or Master Mode.

Integrated level translators allow easy interfacing between the CS5346 and other devices operating over a wide range of logic levels.

The CS5346 is available in a 48-pin LQFP package in Commercial (-40° to $+85^{\circ}$ C) grade. The CDB5346 Customer Demonstration board is also available for device evaluation and implementation suggestions. Please refer to “[Ordering Information](#)” on [page 38](#) for complete details.

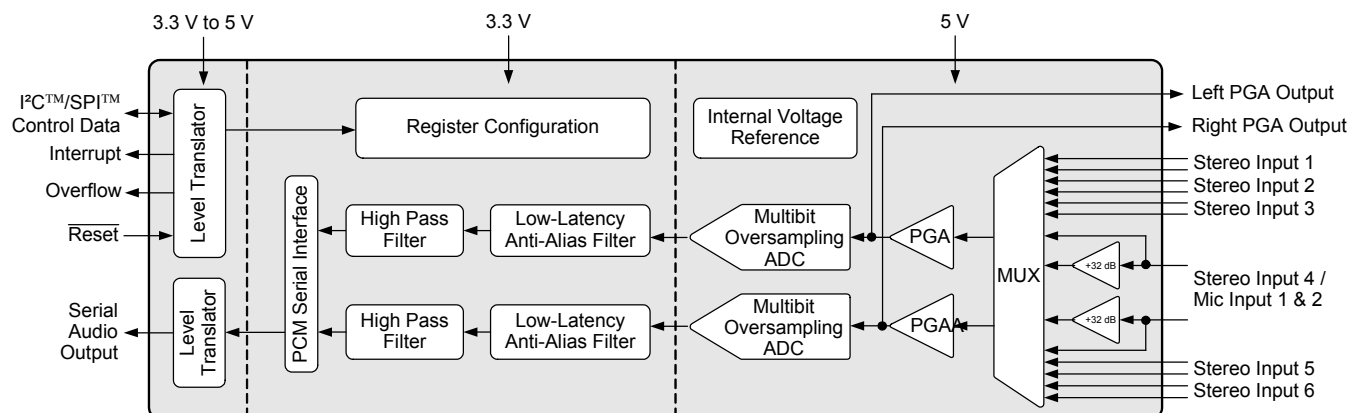

TABLE OF CONTENTS

1. PIN DESCRIPTIONS - CS5346	5
2. PIN COMPATIBILITY - CS5345/CS5346 DIFFERENCES	7
3. CHARACTERISTICS AND SPECIFICATIONS	8
RECOMMENDED OPERATING CONDITIONS	8
ABSOLUTE MAXIMUM RATINGS	8
ANALOG CHARACTERISTICS	9
ANALOG CHARACTERISTICS CONT.	10
DIGITAL FILTER CHARACTERISTICS	11
DC ELECTRICAL CHARACTERISTICS	12
DIGITAL INTERFACE CHARACTERISTICS	13
SWITCHING CHARACTERISTICS - SERIAL AUDIO PORT	14
SWITCHING CHARACTERISTICS - CONTROL PORT - I ² C FORMAT	16
SWITCHING CHARACTERISTICS - CONTROL PORT - SPI FORMAT	17
4. TYPICAL CONNECTION DIAGRAM	18
5. APPLICATIONS	19
5.1 Recommended Power-Up Sequence	19
5.2 System Clocking	19
5.2.1 Master Clock	19
5.2.2 Master Mode	20
5.2.3 Slave Mode	20
5.3 High-Pass Filter and DC Offset Calibration	20
5.4 Analog Input Multiplexer, PGA, and Mic Gain	21
5.5 Input Connections	21
5.5.1 Analog Input Configuration for 1 VRMS Input Levels	21
5.5.2 Analog Input Configuration for 2 VRMS Input Levels	22
5.6 PGA Auxiliary Analog Output	23
5.7 Control Port Description and Timing	23
5.7.1 SPI Mode	23
5.7.2 I ² C Mode	24
5.8 Interrupts and Overflow	25
5.9 Reset	26
5.10 Synchronization of Multiple Devices	26
5.11 Grounding and Power Supply Decoupling	26
6. REGISTER QUICK REFERENCE	27
7. REGISTER DESCRIPTION	28
7.1 Chip ID - Register 01h	28
7.2 Power Control - Address 02h	28
7.2.1 Freeze (Bit 7)	28
7.2.2 Power-Down MIC (Bit 3)	28
7.2.3 Power-Down ADC (Bit 2)	28
7.2.4 Power-Down Device (Bit 0)	28
7.3 ADC Control - Address 04h	29
7.3.1 Functional Mode (Bits 7:6)	29
7.3.2 Digital Interface Format (Bit 4)	29
7.3.3 Mute (Bit 2)	29
7.3.4 High-Pass Filter Freeze (Bit 1)	29
7.3.5 Master / Slave Mode (Bit 0)	29
7.4 MCLK Frequency - Address 05h	30
7.4.1 Master Clock Dividers (Bits 6:4)	30
7.5 PGAOut Control - Address 06h	30
7.5.1 PGAOut Source Select (Bit 6)	30
7.6 Channel B PGA Control - Address 07h	30

7.6.1 Channel B PGA Gain (Bits 5:0)	30
7.7 Channel A PGA Control - Address 08h	31
7.7.1 Channel A PGA Gain (Bits 5:0)	31
7.8 ADC Input Control - Address 09h	31
7.8.1 PGA Soft Ramp or Zero Cross Enable (Bits 4:3)	31
7.8.2 Analog Input Selection (Bits 2:0)	32
7.9 Active Level Control - Address 0Ch	32
7.9.1 Active High/ Low (Bit 0)	32
7.10 Status - Address 0Dh	32
7.10.1 Clock Error (Bit 3)	33
7.10.2 Overflow (Bit 1)	33
7.10.3 Underflow (Bit 0)	33
7.11 Status Mask - Address 0Eh	33
7.12 Status Mode MSB - Address 0Fh	33
7.13 Status Mode LSB - Address 10h	33
8. PARAMETER DEFINITIONS	34
9. FILTER PLOTS	35
10. PACKAGE DIMENSIONS	37
11. THERMAL CHARACTERISTICS AND SPECIFICATIONS	37
12. ORDERING INFORMATION	38
13. REVISION HISTORY	38

LIST OF FIGURES

Figure 1.Master Mode Serial Audio Port Timing	15
Figure 2.Slave Mode Serial Audio Port Timing	15
Figure 3.Format 0, 24-Bit Data Left-Justified	15
Figure 4.Format 1, 24-Bit Data I ² S	15
Figure 5.Control Port Timing - I ² C Format	16
Figure 6.Control Port Timing - SPI Format	17
Figure 7.Typical Connection Diagram	18
Figure 8.Master Mode Clocking	20
Figure 9.Analog Input Architecture	21
Figure 10.CS5346 PGA	22
Figure 11.1 V _{RMS} Input Circuit	22
Figure 12.1 V _{RMS} Input Circuit with RF Filtering	22
Figure 13.2 V _{RMS} Input Circuit	22
Figure 14.Control Port Timing in SPI Mode	24
Figure 15.Control Port Timing, I ² C Write	24
Figure 16.Control Port Timing, I ² C Read	25
Figure 17.Single-Speed Stopband Rejection	35
Figure 18.Single-Speed Stopband Rejection	35
Figure 19.Single-Speed Transition Band (Detail)	35
Figure 20.Single-Speed Passband Ripple	35
Figure 21.Double-Speed Stopband Rejection	35
Figure 22.Double-Speed Stopband Rejection	35
Figure 23.Double-Speed Transition Band (Detail)	36
Figure 24.Double-Speed Passband Ripple	36
Figure 25.Quad-Speed Stopband Rejection	36
Figure 26.Quad-Speed Stopband Rejection	36
Figure 27.Quad-Speed Transition Band (Detail)	36
Figure 28.Quad-Speed Passband Ripple	36

LIST OF TABLES

Table 1. Speed Modes	19
Table 2. Common Clock Frequencies	19
Table 3. Slave Mode Serial Bit Clock Ratios	20
Table 4. Device Revision	28
Table 5. Freeze-able Bits	28
Table 6. Functional Mode Selection	29
Table 7. Digital Interface Formats	29
Table 8. MCLK Frequency	30
Table 9. PGAOut Source Selection	30
Table 10. Example Gain and Attenuation Settings	31
Table 11. PGA Soft Cross or Zero Cross Mode Selection	32
Table 12. Analog Input Multiplexer Selection	32

1. PIN DESCRIPTIONS - CS5346

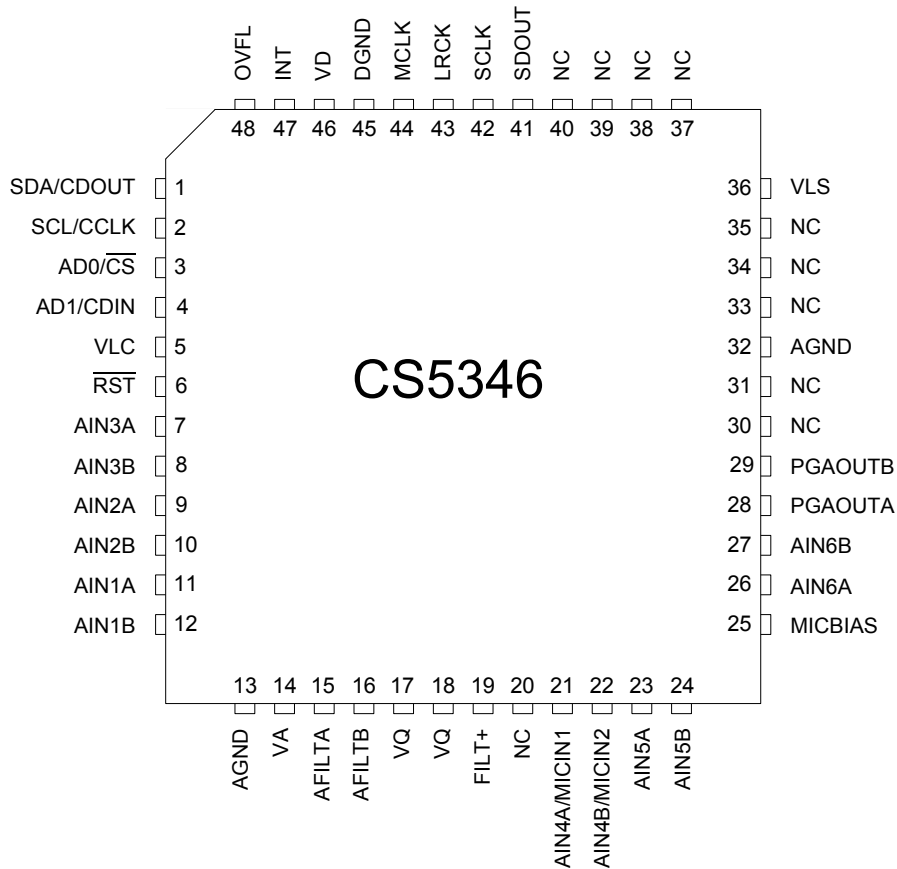

Pin Name	#	Pin Description
SDA/CDOUT	1	Serial Control Data (Input/Output) - SDA is a data I/O in I ² C [®] Mode. CDOUT is the output data line for the control port interface in SPI [™] Mode.
SCL/CCLK	2	Serial Control Port Clock (Input) - Serial clock for the serial control port.
AD0/ \overline{CS}	3	Address Bit 0 (I²C) / Control Port Chip Select (SPI) (Input) - AD0 is a chip address pin in I ² C Mode; \overline{CS} is the chip-select signal for SPI format.
AD1/CDIN	4	Address Bit 1 (I²C) / Serial Control Data Input (SPI) (Input) - AD1 is a chip address pin in I ² C Mode; CDIN is the input data line for the control port interface in SPI Mode.
VLC	5	Control Port Power (Input) - Determines the required signal level for the control port interface. Refer to the Recommended Operating Conditions for appropriate voltages.
\overline{RST}	6	Reset (Input) - The device enters a low-power mode when this pin is driven low.
AIN3A AIN3B	7 8	Stereo Analog Input 3 (Input) - The full-scale level is specified in the Analog Characteristics specification table.
AIN2A AIN2B	9 10	Stereo Analog Input 2 (Input) - The full-scale level is specified in the Analog Characteristics specification table.

AIN1A	11	Stereo Analog Input 1 (Input) - The full-scale level is specified in the Analog Characteristics specification table.
AIN1B	12	
AGND	13	Analog Ground (Input) - Ground reference for the internal analog section.
VA	14	Analog Power (Input) - Positive power for the internal analog section.
AFILTA	15	Anti-alias Filter Connection (Output) - Antialias filter connection for the channel A ADC input.
AFILTB	16	Anti-alias Filter Connection (Output) - Antialias filter connection for the channel B ADC input.
VQ	17 18	Quiescent Voltage (Output) - Filter connection for the internal quiescent reference voltage.
FILT+	19	Positive Voltage Reference (Output) - Positive reference voltage for the internal sampling circuits.
NC	20	No Connect - This pin is not connected internally and should be tied to ground to minimize any potential coupling effects.
AIN4A/MICIN1	21	Stereo Analog Input 4 / Microphone Input 1 & 2 (Input) - The full-scale level is specified in the Analog Characteristics specification table.
AIN4B/MICIN2	22	
AIN5A	23	Stereo Analog Input 5 (Input) - The full-scale level is specified in the Analog Characteristics specification table.
AIN5B	24	
MICBIAS	25	Microphone Bias Supply (Output) - Low-noise bias supply for external microphone. Electrical characteristics are specified in the DC Electrical Characteristics specification table.
AIN6A	26	Stereo Analog Input 6 (Input) - The full-scale level is specified in the Analog Characteristics specification table.
AIN6B	27	
PGAOUTA	28	PGA Analog Audio Output (Output) - Either an analog output from the PGA block or high impedance. See “PGAOut Source Select (Bit 6)” on page 30 .
PGAOUTB	29	
NC	30 31	No Connect - These pins are not connected internally and should be tied to ground to minimize any potential coupling effects.
AGND	32	Analog Ground (Input) - Ground reference for the internal analog section.
NC	33 34 35	No Connect - These pins are not connected internally and should be tied to ground to minimize any potential coupling effects.
VLS	36	Serial Audio Interface Power (Input) - Determines the required signal level for the serial audio interface. Refer to the Recommended Operating Conditions for appropriate voltages.
NC	37 38 39 40	No Connect - These pins are not connected internally and should be tied to ground to minimize any potential coupling effects.
SDOUT	41	Serial Audio Data Output (Output) - Output for two’s complement serial audio data.
SCLK	42	Serial Clock (Input/Output) - Serial clock for the serial audio interface.
LRCK	43	Left Right Clock (Input/Output) - Determines which channel, Left or Right, is currently active on the serial audio data line.
MCLK	44	Master Clock (Input) - Clock source for the ADC’s delta-sigma modulators.
DGND	45	Digital Ground (Input) - Ground reference for the internal digital section.
VD	46	Digital Power (Input) - Positive power for the internal digital section.
INT	47	Interrupt (Output) - Indicates an interrupt condition has occurred.
OVFL	48	Overflow (Output) - Indicates an ADC overflow condition is present.

2. PIN COMPATIBILITY - CS5345/CS5346 DIFFERENCES

The CS5346 is pin compatible with the CS5345 and is a drop in replacement for CS5345 applications where $V_A = 5\text{ V}$, $V_D = 3.3\text{ V}$, $V_{LS} \geq 3.3\text{ V}$, and $V_{LC} \geq 3.3\text{ V}$. The pinout diagram and table below show the requirements for the remaining pins when replacing the CS5345 in these designs with a CS5346.

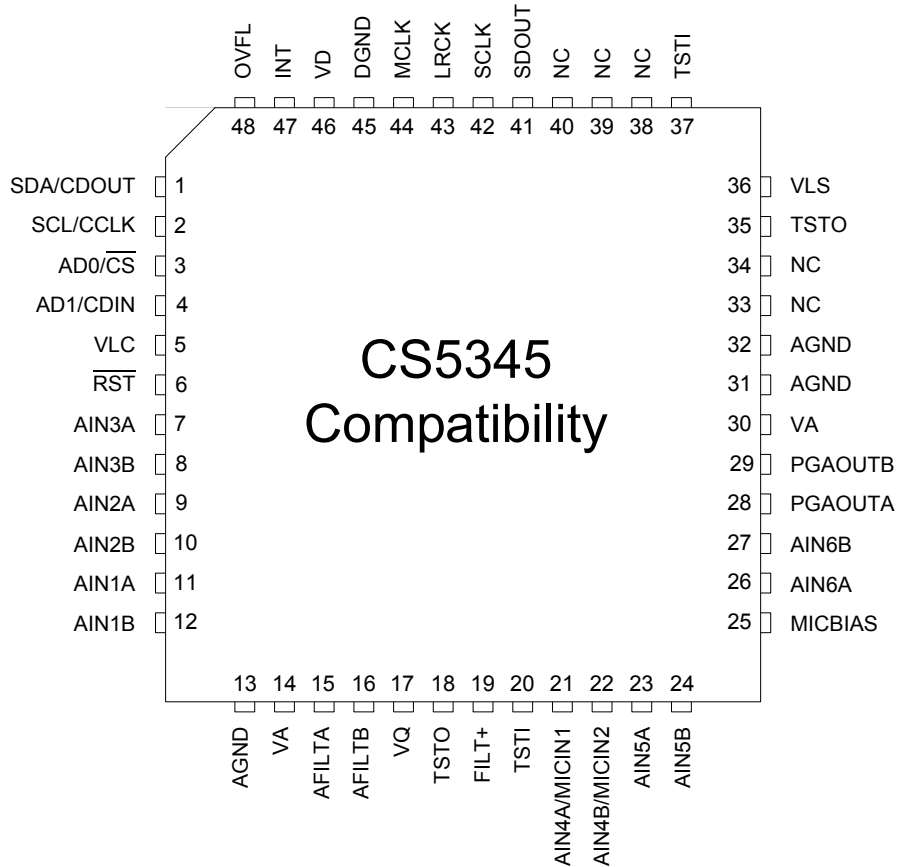

#	CS5345 Pin Name	CS5346 Pin Name	CS5346 Connection for Compatibility
5	VLC	VLC	Control Port Power (Input) - Limited to nominal 5 or 3.3 V.
14	VA	VA	Analog Power (Input) - Limited to nominal 5 V.
18	TSTO	VQ	This pin must be left unconnected.
20	TSTI	NC	This pin should be tied to ground.
30	VA	NC	This pin may be connected to the analog supply voltage. The decoupling capacitor for the CS5345 is not required.
31	AGND	NC	This pin should be connected to ground.
35	TSTO	NC	This pin may be left unconnected.
36	VLS	VLS	Serial Audio Interface Power (Input) - Limited to nominal 5 or 3.3 V.
37	TSTI	NC	This pin should be tied to ground.
46	VD	VD	Digital Power (Input) - Limited to nominal 3.3 V

3. CHARACTERISTICS AND SPECIFICATIONS

RECOMMENDED OPERATING CONDITIONS

AGND = DGND = 0 V; All voltages with respect to ground.

Parameters	Symbol	Min	Nom	Max	Units	
DC Power Supplies:	Analog	VA	4.75	5.0	5.25	V
	Digital	VD	3.13	3.3	3.47	V
	Logic - Serial Port	VLS	3.13	3.3	5.25	V
	Logic - Control Port	VLC	3.13	3.3	5.25	V
Ambient Operating Temperature (Power Applied)	Commercial	T_A	-40	-	+85	°C

ABSOLUTE MAXIMUM RATINGS

AGND = DGND = 0 V All voltages with respect to ground. (Note 1)

Parameter	Symbol	Min	Max	Units	
DC Power Supplies:	Analog	VA	-0.3	+6.0	V
	Digital	VD	-0.3	+3.63	V
	Logic - Serial Port	VLS	-0.3	+6.0	V
	Logic - Control Port	VLC	-0.3	+6.0	V
Input Current	(Note 2)	I_{in}	-	±10	mA
Analog Input Voltage	V_{INA}	AGND-0.3	VA+0.3	V	
Digital Input Voltage	Logic - Serial Port	V_{IND-S}	-0.3	VLS+0.3	V
	Logic - Control Port	V_{IND-C}	-0.3	VLC+0.3	V
Ambient Operating Temperature (Power Applied)	T_A	-50	+125	°C	
Storage Temperature	T_{stg}	-65	+150	°C	

- Notes:**
1. Operation beyond these limits may result in permanent damage to the device. Normal operation is not guaranteed at these extremes.
 2. Any pin except supplies. Transient currents of up to ±100 mA on the analog input pins will not cause SCR latch-up.

ANALOG CHARACTERISTICS

Test conditions (unless otherwise specified): $V_A = 5\text{ V}$; $V_D = V_L = V_{LC} = 3.3\text{ V}$; $AGND = DGND = 0\text{ V}$;
 $T_A = +25^\circ\text{ C}$; Input test signal: 1 kHz sine wave; measurement bandwidth is 10 Hz to 20 kHz; $F_s = 48/96/192\text{ kHz}$;
 PGA gain = 0 dB; All connections as shown in [Figure 7 on page 18](#).

Parameter	Symbol	Min	Typ	Max	Unit
Analog-to-Digital Converter Characteristics					
Dynamic Range (Line Level Inputs)	A-weighted	97	103	-	dB
	unweighted	94	100	-	dB
	(Note 3) 40 kHz bandwidth unweighted	-	98	-	dB
Total Harmonic Distortion + Noise (Line Level Inputs)	(Note 4)				
	-1 dB	-	-95	-89	dB
	-20 dB	-	-80	-	dB
	(Note 3) 40 kHz bandwidth -1 dB	-	-92	-	dB
Dynamic Range (Mic Level Inputs)	A-weighted	77	83	-	dB
	unweighted	74	80	-	dB
Total Harmonic Distortion + Noise (Mic Level Inputs)	(Note 4)				
	-1 dB	-	-80	-74	dB
	-20 dB	-	-60	-	dB
	(Note 3) -60 dB	-	-20	-	dB
Interchannel Isolation	(Line Level Inputs)	-	90	-	dB
	(Mic Level Inputs)	-	80	-	dB
A/D Full-scale Input Voltage		0.51* V_A	0.57* V_A	0.63* V_A	V_{pp}
Gain Error		-	-	± 10	%
Interchannel Gain Mismatch		-	0.1	-	dB
Microphone - Level Input Characteristics					
Preamplifier Gain		31	32	33	dB
		35.5	40	44.7	V/V
Interchannel Gain Mismatch		-	0.1	-	dB
Input Impedance	(Note 5)	-	60	-	k Ω

3. Valid for Double- and Quad-Speed Modes only.
4. Referred to the typical A/D full-scale input voltage
5. Valid when the microphone-level inputs are selected.

ANALOG CHARACTERISTICS CONT.

Parameter	Symbol	Min	Typ	Max	Unit
Line-Level Input and Programmable Gain Amplifier					
Gain Range		- 12 -4	- -	+ 12 +4	dB V/V
Gain Step Size		-	0.5	-	dB
Absolute Gain Step Error		-	-	0.4	dB
Maximum Input Level		-	-	0.85*VA	V _{pp}
Input Impedance					
	Selected inputs	28.8	36	43.2	kΩ
	Un-selected inputs	-	-	38	kΩ
Selected Interchannel Input Impedance Mismatch		-	5	-	%
Analog Outputs					
Dynamic Range (Line Level Inputs)					
	A-weighted	98	104	-	dB
	unweighted	95	101	-	dB
Total Harmonic Distortion + Noise (Line Level Inputs)	(Note 6)				
	-1 dB	-	-80	-74	dB
	-20 dB	-	-81	-	dB
	-60 dB	-	-41	-	dB
Dynamic Range (Mic Level Inputs)					
	A-weighted	77	83	-	dB
	unweighted	74	80	-	dB
Total Harmonic Distortion + Noise (Mic Level Inputs)	(Note 6)				
	-1 dB	-	-74	-68	dB
	-20 dB	-	-60	-	dB
	-60 dB	-	-20	-	dB
Frequency Response 10 Hz to 20 kHz		-0.1dB	-	+0.1dB	dB
Analog In to Analog Out Phase Shift		-	180	-	deg
DC Current draw from a PGOOUT pin	I _{OUT}	-	-	1	μA
AC-Load Resistance	R _L	100	-	-	kΩ
Load Capacitance	C _L	-	-	20	pF

6. Referred to the typical A/D Full-Scale Input Voltage.

DIGITAL FILTER CHARACTERISTICS

Parameter (Note 7)	Symbol	Min	Typ	Max	Unit
Single-Speed Mode					
Passband (-0.1 dB)		0	-	0.4896	Fs
Passband Ripple		-	-	0.035	dB
Stopband		0.5688	-	-	Fs
Stopband Attenuation		70	-	-	dB
Total Group Delay (Fs = Output Sample Rate)	t_{gd}	-	12/Fs	-	s
Double-Speed Mode					
Passband (-0.1 dB)		0	-	0.4896	Fs
Passband Ripple		-	-	0.025	dB
Stopband		0.5604	-	-	Fs
Stopband Attenuation		69	-	-	dB
Total Group Delay (Fs = Output Sample Rate)	t_{gd}	-	9/Fs	-	s
Quad-Speed Mode					
Passband (-0.1 dB)		0	-	0.2604	Fs
Passband Ripple		-	-	0.025	dB
Stopband		0.5000	-	-	Fs
Stopband Attenuation		60	-	-	dB
Total Group Delay (Fs = Output Sample Rate)	t_{gd}	-	5/Fs	-	s
High-Pass Filter Characteristics					
Frequency Response	-3.0 dB		-	1	Hz
	-0.13 dB	(Note 8)		20	Hz
Phase Deviation	@ 20 Hz	(Note 8)		10	Deg
Passband Ripple				0	dB
Filter Settling Time				$10^5/Fs$	s

7. Response is clock-dependent and will scale with Fs. Note that the response plots (Figures 17 to 28) are normalized to Fs and can be de-normalized by multiplying the X-axis scale by Fs.
8. Response shown is for Fs = 48 kHz.

DC ELECTRICAL CHARACTERISTICS

AGND = DGND = 0 V, all voltages with respect to ground. MCLK=12.288 MHz; Fs=48 kHz; Master Mode.

Parameter	Symbol	Min	Typ	Max	Unit
Power Supply Current (Normal Operation)	VA = 5 V IA	-	41	50	mA
	VD, VLS, VLC = 3.3 V ID	-	23	28	mA
Power Supply Current (Power-Down Mode) (Note 9)	VA = 5 V IA	-	0.50	-	mA
	VLS, VLC, VD = 3.3 V ID	-	0.54	-	mA
Power Consumption (Normal Operation)	VA = 5 V	-	205	250	mW
	VD, VLS, VLC = 3.3 V	-	76	93	mW
	VA = 5V; VD, VLS, VLC = 3.3 V	-	4.2	-	mW
Power Supply Rejection Ratio (1 kHz)	PSRR	-	55	-	dB
VQ Characteristics					
Quiescent Voltage	VQ	-	0.5 x VA	-	VDC
Maximum DC Current from VQ	IQ	-	1	-	μA
VQ Output Impedance	ZQ	-	23	-	kΩ
FILT+ Nominal Voltage	FILT+	-	VA	-	VDC
Microphone Bias Voltage	MICBIAS	-	0.8 x VA	-	VDC
Current from MICBIAS	IMB	-	-	2	mA

9. Power-Down Mode is defines as \overline{RST} = Low with all clock and data lines held static and no analog input.
10. Valid with the recommended capacitor values on FILT+ and VQ as shown in the Typical Connection Diagram.

DIGITAL INTERFACE CHARACTERISTICS

Test conditions (unless otherwise specified): AGND = DGND = 0 V; VLS = VLC = 3.3 V.

Parameters (Note 11)	Symbol	Min	Typ	Max	Units	
High-Level Input Voltage	Serial Port	V_{IH}	0.7xVLS	-	-	V
	Control Port	V_{IH}	0.7xVLC	-	-	V
Low-Level Input Voltage	Serial Port	V_{IL}	-	-	0.3xVLS	V
	Control Port	V_{IL}	-	-	0.3xVLC	V
High-Level Output Voltage at $I_o = 2$ mA	Serial Port	V_{OH}	VLS-1.0	-	-	V
	Control Port	V_{OH}	VLC-1.0	-	-	V
Low-Level Output Voltage at $I_o = 2$ mA	Serial Port	V_{OL}	-	-	0.4	V
	Control Port	V_{OL}	-	-	0.4	V
Input Leakage Current		I_{in}	-	-	±10	μA
Input Capacitance			-	1	-	pF
Minimum OVFL Active Time			$\frac{10^6}{LRCK}$	-	-	μs

11. Serial Port signals include: MCLK, SCLK, LRCK, SDOUT.

Control Port signals include: SCL/CCLK, SDA/CDOUT, $\overline{AD0/CS}$, $\overline{AD1/CDIN}$, \overline{RST} , INT, OVFL.

SWITCHING CHARACTERISTICS - SERIAL AUDIO PORT

Logic '0' = DGND = AGND = 0 V; Logic '1' = VLS, $C_L = 20$ pF. (Note 12)

Parameter	Symbol	Min	Typ	Max	Unit	
Sample Rate	Single-Speed Mode	F_s	8	-	50	kHz
	Double-Speed Mode	F_s	50	-	100	kHz
	Quad-Speed Mode	F_s	100	-	200	kHz
MCLK Specifications						
MCLK Frequency	f_{mclk}	2.048	-	51.200	MHz	
MCLK Input Pulse Width High/Low	t_{clkhl}	8	-	-	ns	
Master Mode						
LRCK Duty Cycle		-	50	-	%	
SCLK Duty Cycle		-	50	-	%	
SCLK falling to LRCK edge	t_{slr}	-10	-	10	ns	
SCLK falling to SDOUT valid	t_{sdo}	0	-	36	ns	
Slave Mode						
LRCK Duty Cycle		40	50	60	%	
SCLK Period	Single-Speed Mode	t_{sclkw}	$\frac{10^9}{(128)F_s}$	-	-	ns
	Double-Speed Mode	t_{sclkw}	$\frac{10^9}{(64)F_s}$	-	-	ns
	Quad-Speed Mode	t_{sclkw}	$\frac{10^9}{(64)F_s}$	-	-	ns
SCLK Pulse Width High	t_{sclkh}	30	-	-	ns	
SCLK Pulse Width Low	t_{sclkl}	48	-	-	ns	
SCLK falling to LRCK edge	t_{slr}	-10	-	10	ns	
SCLK falling to SDOUT valid	t_{sdo}	0	-	36	ns	

12. See Figure 1 and Figure 2 on page 15.

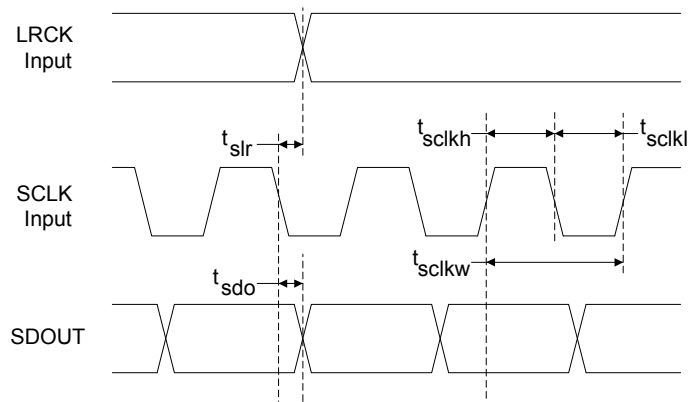
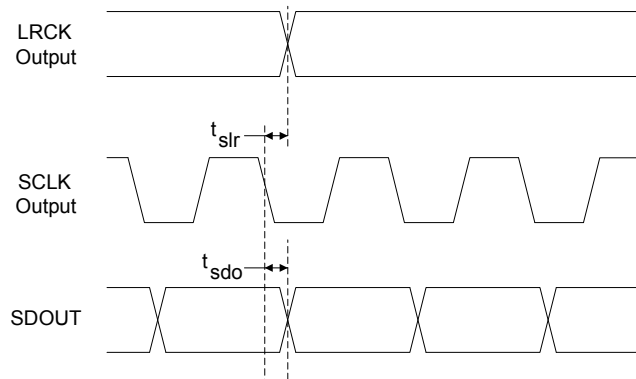
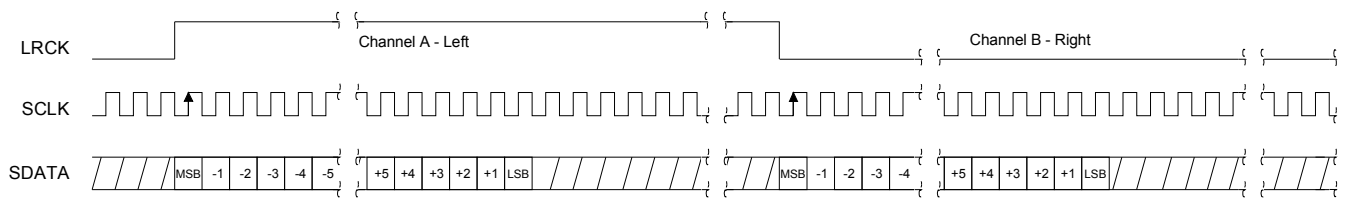
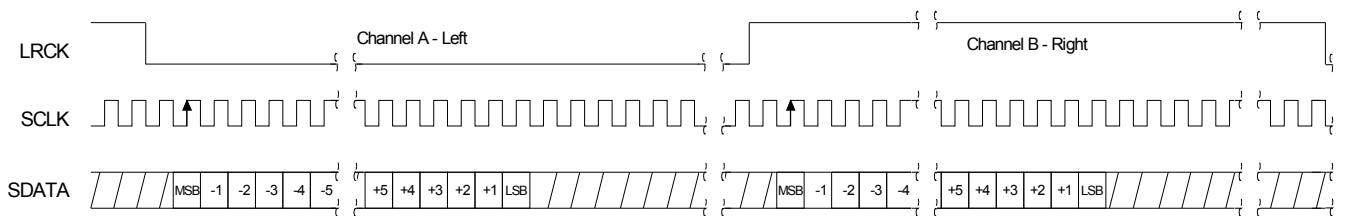
Figure 1. Master Mode Serial Audio Port Timing

Figure 2. Slave Mode Serial Audio Port Timing

Figure 3. Format 0, 24-Bit Data Left-Justified

Figure 4. Format 1, 24-Bit Data I²S

SWITCHING CHARACTERISTICS - CONTROL PORT - I²C FORMAT

Inputs: Logic 0 = DGND = AGND = 0 V, Logic 1 = VLC, $C_L = 30$ pF.

Parameter	Symbol	Min	Max	Unit
SCL Clock Frequency	f_{scl}	-	100	kHz
$\overline{\text{RST}}$ Rising Edge to Start	t_{irs}	500	-	ns
Bus Free Time Between Transmissions	t_{buf}	4.7	-	μs
Start Condition Hold Time (prior to first clock pulse)	t_{hdst}	4.0	-	μs
Clock Low time	t_{low}	4.7	-	μs
Clock High Time	t_{high}	4.0	-	μs
Setup Time for Repeated Start Condition	t_{sust}	4.7	-	μs
SDA Hold Time from SCL Falling	t_{hdd}	0	-	μs
SDA Setup time to SCL Rising	t_{sud}	250	-	ns
Rise Time of SCL and SDA	t_{rc}, t_{rd}	-	1	μs
Fall Time SCL and SDA	t_{fc}, t_{fd}	-	300	ns
Setup Time for Stop Condition	t_{susp}	4.7	-	μs
Acknowledge Delay from SCL Falling	t_{ack}	300	1000	ns

13. Data must be held for sufficient time to bridge the transition time, t_{fc} , of SCL.

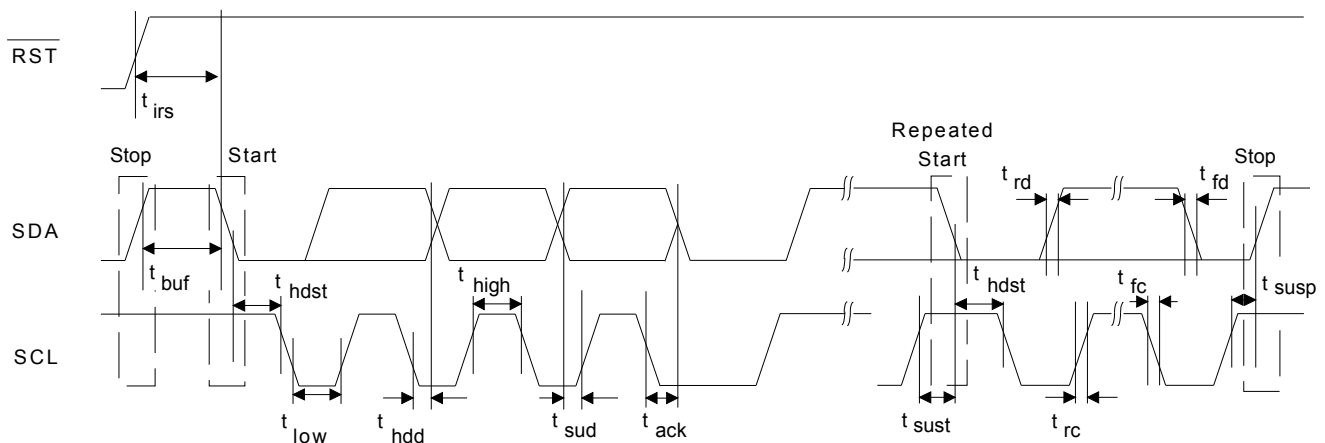

Figure 5. Control Port Timing - I²C Format

SWITCHING CHARACTERISTICS - CONTROL PORT - SPI FORMAT

Inputs: Logic 0 = DGND = AGND = 0 V, Logic 1 = VLC, $C_L = 30$ pF.

Parameter	Symbol	Min	Max	Units
CCLK Clock Frequency	f_{sck}	-	6.0	MHz
\overline{RST} Rising Edge to \overline{CS} Falling	t_{srs}	500	-	ns
\overline{CS} High Time Between Transmissions	t_{csh}	1.0	-	μ s
\overline{CS} Falling to CCLK Edge	t_{css}	20	-	ns
CCLK Low Time	t_{scl}	66	-	ns
CCLK High Time	t_{sch}	66	-	ns
CDIN to CCLK Rising Setup Time	t_{dsu}	40	-	ns
CCLK Rising to DATA Hold Time	t_{dh}	15	-	ns
CCLK Falling to CDOUT Stable	t_{pd}	-	50	ns
Rise Time of CDOUT	t_{r1}	-	25	ns
Fall Time of CDOUT	t_{f1}	-	25	ns
Rise Time of CCLK and CDIN	t_{r2}	-	100	ns
Fall Time of CCLK and CDIN	t_{f2}	-	100	ns

14. Data must be held for sufficient time to bridge the transition time of CCLK.

15. For $f_{sck} < 1$ MHz.

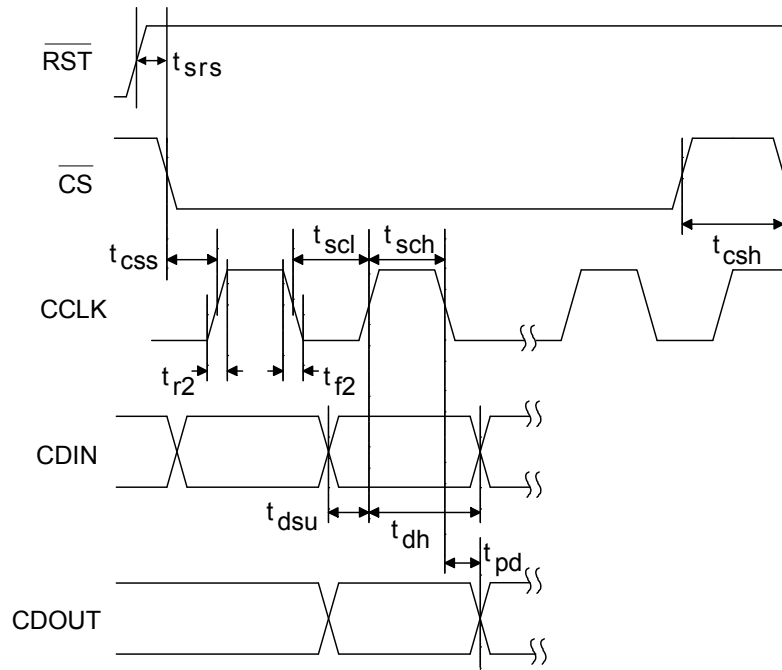

Figure 6. Control Port Timing - SPI Format

4. TYPICAL CONNECTION DIAGRAM

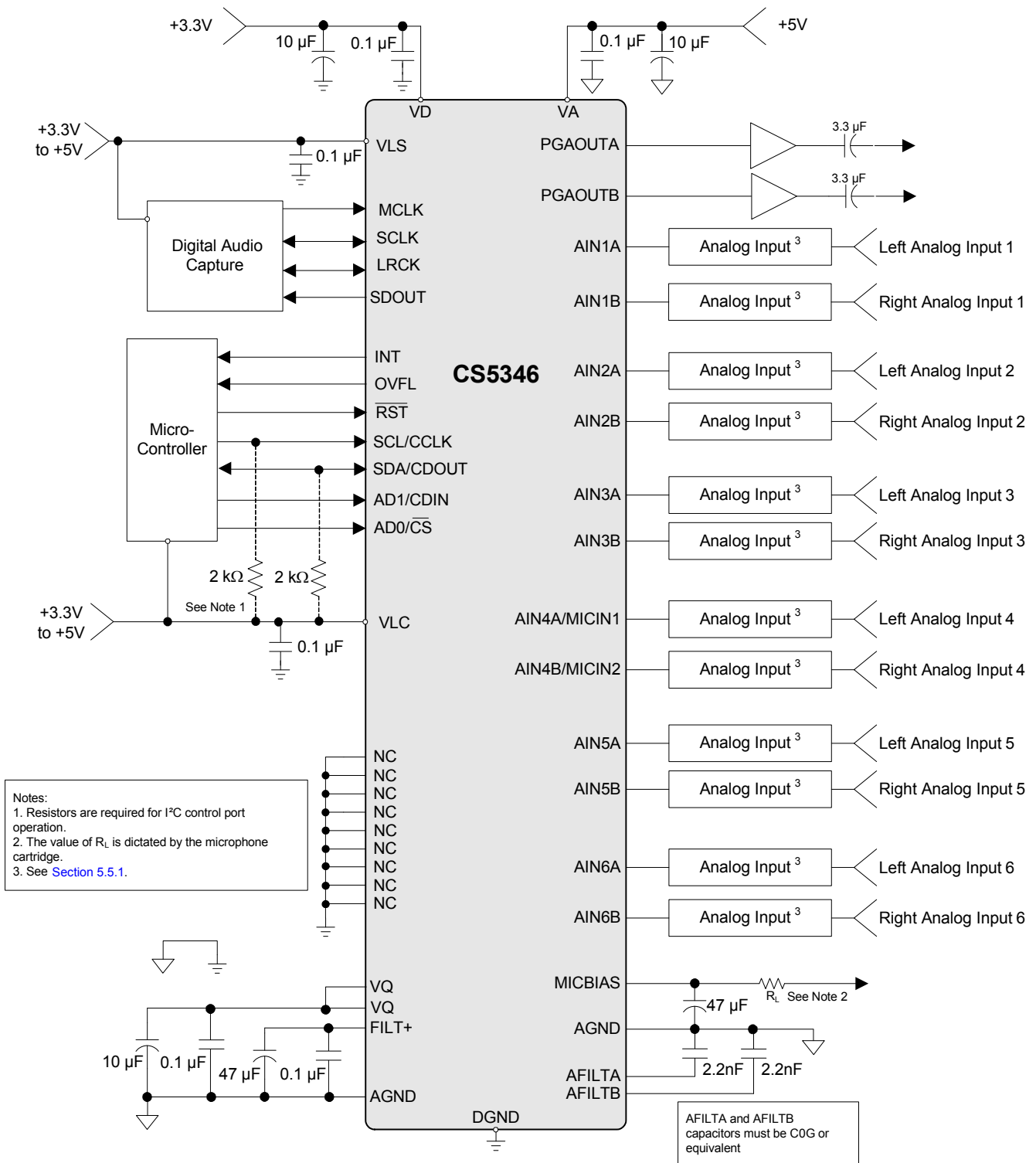

Figure 7. Typical Connection Diagram

5. APPLICATIONS

5.1 Recommended Power-Up Sequence

1. Hold $\overline{\text{RST}}$ low until the power supply, MCLK, and LRCK are stable. In this state, the Control Port is reset to its default settings.
2. Bring $\overline{\text{RST}}$ high. The device will remain in a low power state with the PDN bit set by default. The control port will be accessible.
3. The desired register settings can be loaded while the PDN bit remains set.
4. Clear the PDN bit to initiate the power-up sequence.

5.2 System Clocking

The CS5346 will operate at sampling frequencies from 8 kHz to 200 kHz. This range is divided into three speed modes as shown in [Table 1](#).

Mode	Sampling Frequency
<i>Single-Speed</i>	8-50 kHz
<i>Double-Speed</i>	50-100 kHz
<i>Quad-Speed</i>	100-200 kHz

Table 1. Speed Modes

5.2.1 Master Clock

MCLK/LRCK must maintain an integer ratio as shown in [Table 2](#). The LRCK frequency is equal to F_s , the frequency at which audio samples for each channel are clocked out of the device. The FM bits (See “[Functional Mode \(Bits 7:6\)](#)” on page 29.) and the MCLK Freq bits (See “[MCLK Frequency - Address 05h](#)” on page 30.) configure the device to generate the proper clocks in Master Mode and receive the proper clocks in Slave Mode. [Table 2](#) illustrates several standard audio sample rates and the required MCLK and LRCK frequencies.

LRCK (kHz)	MCLK (MHz)								
	* 64x	* 96x	128x	192x	256x	384x	512x	768x	1024x
32	-	-	-	-	8.1920	12.2880	16.3840	24.5760	32.7680
44.1	-	-	-	-	11.2896	16.9344	22.5792	33.8680	45.1584
48	-	-	-	-	12.2880	18.4320	24.5760	36.8640	49.1520
64	-	-	8.1920	12.2880	16.3840	24.5760	32.7680	-	-
88.2	-	-	11.2896	16.9344	22.5792	33.8680	45.1584	-	-
96	-	-	12.2880	18.4320	24.5760	36.8640	49.1520	-	-
128	8.1920	12.2880	16.3840	24.5760	32.7680	-	-	-	-
176.4	11.2896	16.9344	22.5792	33.8680	45.1584	-	-	-	-
192	12.2880	18.4320	24.5760	36.8640	49.1520	-	-	-	-
Mode	QSM				DSM			SSM	

* Only available in master mode.

Table 2. Common Clock Frequencies

5.2.2 Master Mode

As a clock master, LRCK and SCLK will operate as outputs. LRCK and SCLK are internally derived from MCLK with LRCK equal to F_s and SCLK equal to $64 \times F_s$ as shown in Figure 8.

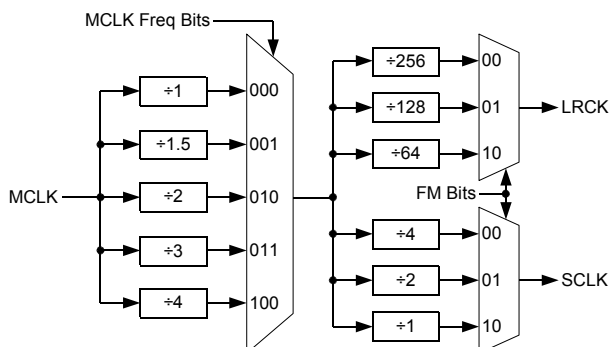

Figure 8. Master Mode Clocking

5.2.3 Slave Mode

In Slave Mode, SCLK and LRCK operate as inputs. The Left/Right clock signal must be equal to the sample rate, F_s , and must be synchronously derived from the supplied master clock, MCLK.

The serial bit clock, SCLK, must be synchronously derived from the master clock, MCLK, and be equal to $128x$, $64x$ or $48x F_s$, depending on the desired speed mode. Refer to Table 3 for required clock ratios.

	Single-Speed	Double-Speed	Quad-Speed
SCLK/LRCK Ratio	48x, 64x, 128x	48x, 64x	48x, 64x

Table 3. Slave Mode Serial Bit Clock Ratios

5.3 High-Pass Filter and DC Offset Calibration

When using operational amplifiers in the input circuitry driving the CS5346, a small DC offset may be driven into the A/D converter. The CS5346 includes a high-pass filter after the decimator to remove any DC offset which could result in recording a DC level, possibly yielding clicks when switching between devices in a multichannel system.

The high-pass filter continuously subtracts a measure of the DC offset from the output of the decimation filter. If the HPFFreeze bit (See “High-Pass Filter Freeze (Bit 1)” on page 29.) is set during normal operation, the current value of the DC offset for the each channel is frozen and this DC offset will continue to be subtracted from the conversion result. This feature makes it possible to perform a system DC offset calibration by:

1. Running the CS5346 with the high-pass filter enabled until the filter settles. See the Digital Filter Characteristics section for filter settling time.
2. Disabling the high-pass filter and freezing the stored DC offset.

A system calibration performed in this way will eliminate offsets anywhere in the signal path between the calibration point and the CS5346.

5.4 Analog Input Multiplexer, PGA, and Mic Gain

The CS5346 contains a stereo 6-to-1 analog input multiplexer followed by a programmable gain amplifier (PGA). The input multiplexer can select one of six possible stereo analog input sources and route it to the PGA. Analog inputs 4A and 4B are able to insert a +32 dB (+40x) gain stage before the input multiplexer, allowing them to be used for microphone-level signals without the need for any external gain. The PGA stage provides ± 12 dB ($\pm 4x$) adjustment in 0.5 dB steps. Figure 9 shows the architecture of the input multiplexer, PGA, and microphone gain stages.

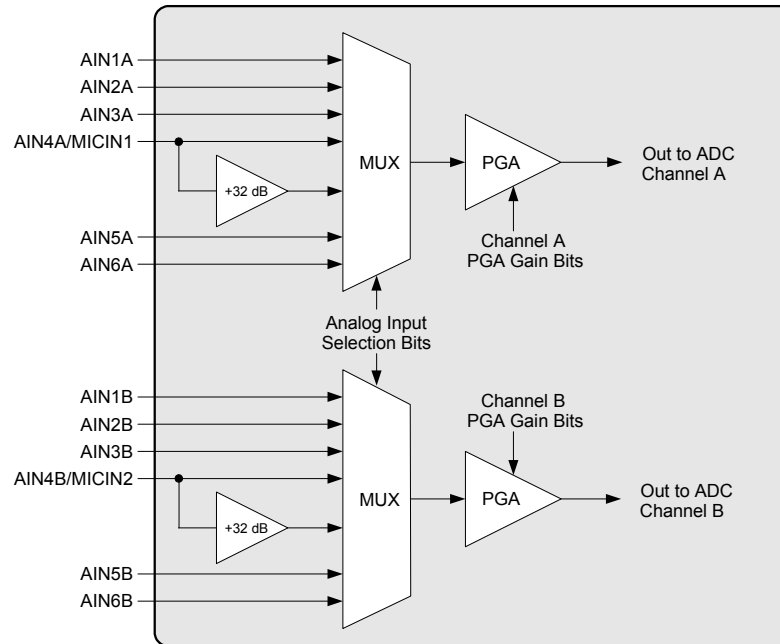

Figure 9. Analog Input Architecture

The “[Analog Input Selection \(Bits 2:0\)](#)” on page 32 outlines the bit settings necessary to control the input multiplexer and mic gain. “[Channel B PGA Control - Address 07h](#)” on page 30 and “[Channel A PGA Control - Address 08h](#)” on page 31 outline the register settings necessary to control the PGA. By default, line-level input 1 is selected, and the PGA is set to 0 dB.

5.5 Input Connections

The analog modulator samples the input at 6.144 MHz (MCLK=12.288 MHz). The digital filter will reject signals within the stopband of the filter. However, there is no rejection for input signals which are $(n \times 6.144 \text{ MHz})$ the digital passband frequency, where $n=0,1,2,\dots$. Refer to the Typical Connection Diagram for the recommended analog input circuit that will attenuate noise energy at 6.144 MHz. The use of capacitors which have a large voltage coefficient (such as general-purpose ceramics) must be avoided since these can degrade signal linearity. Any unused analog input pairs should be left unconnected.

5.5.1 Analog Input Configuration for 1 V_{RMS} Input Levels

The CS5346 PGA, excluding the input multiplexer, is shown in Figure 10 with nominal component values. Interfacing to this circuit is a relatively simple matter and several options are available. The simplest option is shown in Figure 11. However, it may be advantageous in some applications to provide a low-pass filter prior to the PGA to prevent radio frequency interference within the amplifier. The circuit shown in Figure 12

demonstrates a simple solution. The 1800 pF capacitors in the low-pass filter should be C0G or equivalent to avoid distortion issues

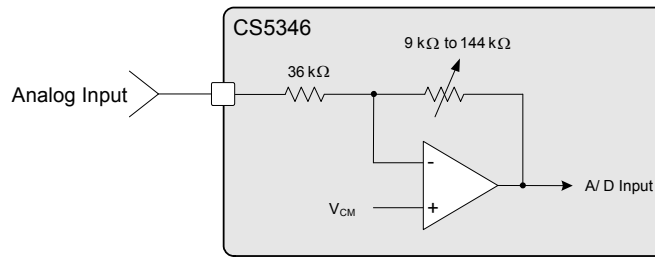

Figure 10. CS5346 PGA

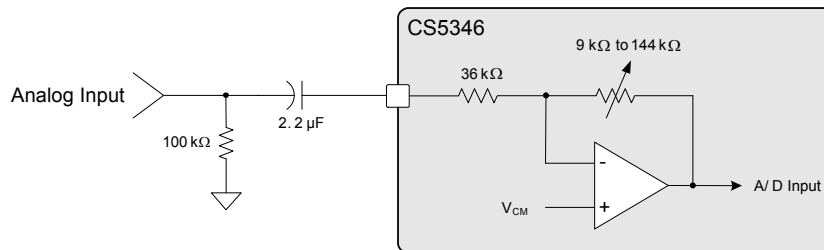

Figure 11. 1 V_{RMS} Input Circuit

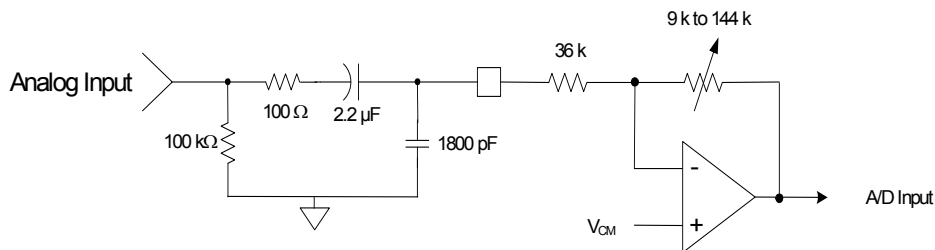

Figure 12. 1 V_{RMS} Input Circuit with RF Filtering

5.5.2 Analog Input Configuration for 2 V_{RMS} Input Levels

The CS5346 can also be easily configured to support an external 2 V_{RMS} input signal, as shown in Figure 13. In this configuration, the 2 V_{RMS} input signal is attenuated to 1.5 V_{RMS} at the analog input with the external 12 k Ω resistor and the input impedance to the network is increased to 48 k Ω . The PGA gain must also be configured to attenuate the 1.5 V_{RMS} at the input pin to the 1.0 V_{RMS} maximum A/D input level to prevent clipping in the ADC.

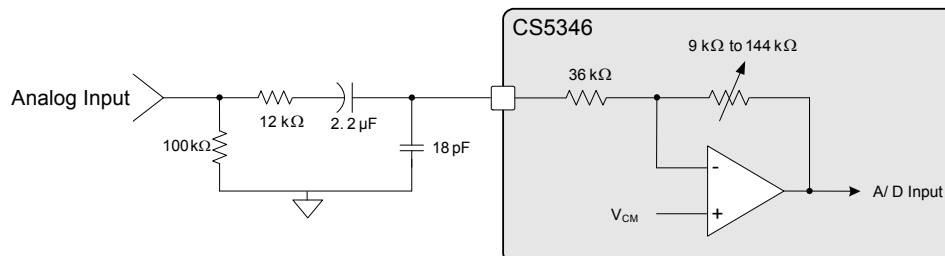

Figure 13. 2 V_{RMS} Input Circuit

5.6 PGA Auxiliary Analog Output

The CS5346 includes an auxiliary analog output through the PGAOUT pins. These pins can be configured to output the analog input to the ADC as selected by the input MUX and gained or attenuated with the PGA, or alternatively, they may be set to high impedance. See the “[PGAOut Source Select \(Bit 6\)](#)” on page 30 for information on configuring the PGA auxiliary analog output.

The PGA auxiliary analog output can source very little current. As current from the PGAOUT pins increases, distortion will increase. For this reason, a high-input impedance buffer must be used on the PGAOUT pins to achieve full performance. An example buffer for PGAOUT is provided on the CDB5346 for reference. Refer to the table in “[DC Electrical Characteristics](#)” on page 12 for acceptable loading conditions.

5.7 Control Port Description and Timing

The control port is used to access the registers, allowing the CS5346 to be configured for the desired operational modes and formats. The operation of the control port may be completely asynchronous with respect to the audio sample rates. However, to avoid potential interference problems, the control port pins should remain static if no operation is required.

The control port has two modes: SPI and I²C, with the CS5346 acting as a slave device. SPI Mode is selected if there is a high-to-low transition on the AD0/CS pin, after the RST pin has been brought high. I²C Mode is selected by connecting the AD0/CS pin through a resistor to VLC or DGND, thereby permanently selecting the desired AD0 bit address state.

5.7.1 SPI Mode

In SPI Mode, \overline{CS} is the chip-select signal; CCLK is the control port bit clock (input into the CS5346 from the microcontroller); CDIN is the input data line from the microcontroller; CDOUT is the output data line to the microcontroller. Data is clocked in on the rising edge of CCLK and out on the falling edge.

Figure 14 shows the operation of the control port in SPI Mode. To write to a register, bring \overline{CS} low. The first seven bits on CDIN form the chip address and must be 1001111. The eighth bit is a read/write indicator (R/W), which should be low to write. The next eight bits form the Memory Address Pointer (MAP), which is set to the address of the register that is to be updated. The next eight bits are the data that will be placed into the register designated by the MAP. During writes, the CDOUT output stays in the Hi-Z state. It may be externally pulled high or low with a 47 k Ω resistor, if desired.

To read a register, the MAP has to be set to the correct address by executing a partial write cycle which finishes (\overline{CS} high) immediately after the MAP byte. To begin a read, bring \overline{CS} low, send out the chip ad-

dress and set the read/write bit ($\overline{R/W}$) high. The next falling edge of CCLK will clock out the MSB of the addressed register (CDOUT will leave the high-impedance state).

For both read and write cycles, the memory address pointer will automatically increment following each data byte in order to facilitate block reads and writes of successive registers.

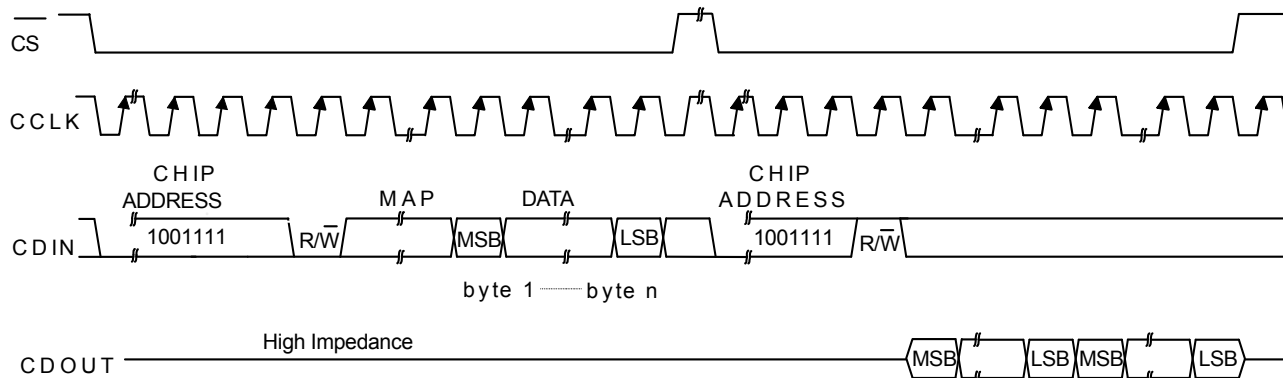

MAP = Memory Address Pointer, 8 bits, MSB first

Figure 14. Control Port Timing in SPI Mode

5.7.2 I²C Mode

In I²C Mode, \overline{SDA} is a bidirectional data line. Data is clocked into and out of the part by the clock, SCL. There is no \overline{CS} pin. Pins AD0 and AD1 form the two least-significant bits of the chip address and should be connected through a resistor to VLC or DGND as desired. The state of the pins is sensed while the CS5346 is being reset.

The signal timings for a read and write cycle are shown in Figure 15 and Figure 16. A Start condition is defined as a falling transition of \overline{SDA} while the clock is high. A Stop condition is a rising transition while the clock is high. All other transitions of \overline{SDA} occur while the clock is low. The first byte sent to the CS5346 after a Start condition consists of a 7-bit chip address field and a R/W bit (high for a read, low for a write). The upper 5 bits of the 7-bit address field are fixed at 10011. To communicate with a CS5346, the chip address field, which is the first byte sent to the CS5346, should match 10011 followed by the settings of the AD1 and AD0. The 8th bit of the address is the R/W bit. If the operation is a write, the next byte is the Memory Address Pointer (MAP) which selects the register to be read or written. If the operation is a read, the contents of the register pointed to by the MAP will be output. Following each data byte, the memory address pointer will automatically increment to facilitate block reads and writes of successive registers. Each byte is separated by an acknowledge bit. The ACK bit is output from the CS5346 after each input byte is read, and is input to the CS5346 from the microcontroller after each transmitted byte.

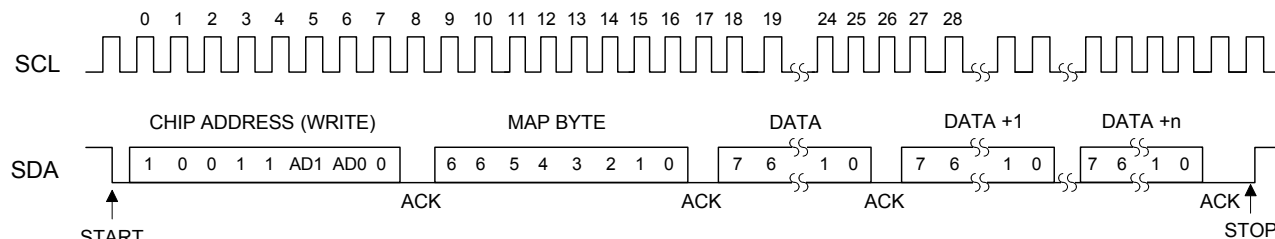

Figure 15. Control Port Timing, I²C Write

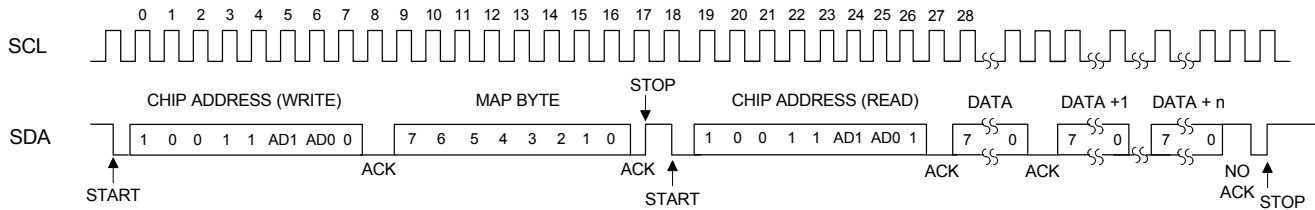

Figure 16. Control Port Timing, I²C Read

Since the read operation cannot set the MAP, an aborted write operation is used as a preamble. As shown in Figure 16, the write operation is aborted after the acknowledge for the MAP byte by sending a stop condition. The following pseudocode illustrates an aborted write operation followed by a read operation.

- Send start condition.
- Send 10011xx0 (chip address & write operation).
- Receive acknowledge bit.
- Send MAP byte.
- Receive acknowledge bit.
- Send stop condition, aborting write.
- Send start condition.
- Send 10011xx1(chip address & read operation).
- Receive acknowledge bit.
- Receive byte, contents of selected register.
- Send acknowledge bit.
- Send stop condition.

5.8 Interrupts and Overflow

The CS5346 has a comprehensive interrupt capability. The INT output pin is intended to drive the interrupt input pin on the host microcontroller. The INT pin may function as either an active high CMOS driver or an active-low, open-drain driver (see “Active High/Low (Bit 0)” on page 35). When configured as active low open-drain, the INT pin has no active pull-up transistor, allowing it to be used for wired-OR hook-ups with multiple peripherals connected to the microcontroller interrupt input pin. In this configuration, an external pull-up resistor must be placed on the INT pin for proper operation.

Many conditions can cause an interrupt, as listed in the interrupt status register descriptions (see “Interrupt Status - Address 0Dh” on page 35). Each source may be masked off through mask register bits. In addition, Each source may be set torising edge, falling edge, or level-sensitive. Combined with the option of level-sensitive or edge-sensitive modes within the microcontroller, many different configurations are possible, depending on the needs of the equipment designer.

The CS5346 also has a dedicated overflow output. The OVFL pin functions as active low open drain and has no active pull-up transistor, thereby requiring an external pull-up resistor. The OVFL pin outputs an OR of the ADCOverflow and ADCUnderflow conditions available in the Interrupt Status register; however, these conditions do not need to be unmasked for proper operation of the OVFL pin.

5.9 Reset

When $\overline{\text{RST}}$ is low, the CS5346 enters a low-power mode and all internal states are reset, including the control port and registers, the outputs are muted. When $\overline{\text{RST}}$ is high, the control port becomes operational, and the desired settings should be loaded into the control registers. Writing a 0 to the PDN bit in the Power Control register will then cause the part to leave the low-power state and begin operation.

The delta-sigma modulators settle in a matter of microseconds after the analog section is powered, either through the application of power or by setting the $\overline{\text{RST}}$ pin high. However, the voltage reference will take much longer to reach a final value due to the presence of external capacitance on the FILT+ pin. During this voltage reference ramp delay, SDOOUT will be automatically muted.

It is recommended that $\overline{\text{RST}}$ be activated if the analog or digital supplies drop below the recommended operating condition to prevent power-glitch-related issues.

5.10 Synchronization of Multiple Devices

In systems where multiple ADCs are required, care must be taken to achieve simultaneous sampling. To ensure synchronous sampling, the master clocks and left/ right clocks must be the same for all of the CS5346s in the system. If only one master clock source is needed, one solution is to place one CS5346 in Master Mode, and slave all of the other CS5346s to the one master. If multiple master clock sources are needed, a possible solution would be to supply all clocks from the same external source and time the CS5346 reset with the inactive edge of master clock. This will ensure that all converters begin sampling on the same clock edge.

5.11 Grounding and Power Supply Decoupling

As with any high-resolution converter, the CS5346 requires careful attention to power supply and grounding arrangements if its potential performance is to be realized. [Figure 7](#) shows the recommended power arrangements, with VA connected to a clean supply. VD, which powers the digital filter, may be run from the system logic supplies (VLS or VLC). Power supply decoupling capacitors should be as near to the CS5346 as possible, with the low value ceramic capacitor being the nearest. All signals, especially clocks, should be kept away from the FILT+ and VQ pins in order to avoid unwanted coupling into the modulators. The FILT+ and VQ decoupling capacitors, particularly the 0.1 μF , must be positioned to minimize the electrical path from FILT+ and AGND. The CS5346 evaluation board demonstrates the optimum layout and power supply arrangements. To minimize digital noise, connect the CS5346 digital outputs only to CMOS inputs.

6. REGISTER QUICK REFERENCE

This table shows the register names and their associated default values.

Addr	Function	7	6	5	4	3	2	1	0
01h pg. 28	Chip ID	PART3	PART2	PART1	PART0	REV3	REV2	REV1	REV0
		1	1	0	0	x	x	x	x
02h pg. 28	Power Control	Freeze	Reserved	Reserved	Reserved	PDN_MIC	PDN_ADC	Reserved	PDN
		0	0	0	0	0	0	0	1
03h	Reserved	Reserved	Reserved	Reserved	Reserved	Reserved	Reserved	Reserved	Reserved
		0	0	0	0	1	0	0	0
04h pg. 29	ADC Control	FM1	FM0	Reserved	DIF	Reserved	Mute	HPFFreeze	M/S
		0	0	0	0	0	0	0	0
05h pg. 30	MCLK Frequency	Reserved	MCLK Freq2	MCLK Freq1	MCLK Freq0	Reserved	Reserved	Reserved	Reserved
		0	0	0	0	0	0	0	0
06h pg. 30	PGAOut Control	Reserved	PGAOut	Reserved	Reserved	Reserved	Reserved	Reserved	Reserved
		0	1	0	0	0	0	0	0
07h pg. 30	PGA Ch B Gain Control	Reserved	Reserved	Gain5	Gain4	Gain3	Gain2	Gain1	Gain0
		0	0	0	0	0	0	0	0
08h pg. 31	PGA Ch A Gain Control	Reserved	Reserved	Gain5	Gain4	Gain3	Gain2	Gain1	Gain0
		0	0	0	0	0	0	0	0
09h pg. 31	Analog Input Control	Reserved	Reserved	Reserved	PGASoft	PGAZero	Sel2	Sel1	Sel0
		0	0	0	1	1	0	0	1
0Ah - 0Bh	Reserved	Reserved	Reserved	Reserved	Reserved	Reserved	Reserved	Reserved	Reserved
		0	0	0	0	0	0	0	0
0Ch pg. 32	Active Level Control	Reserved	Reserved	Reserved	Reserved	Reserved	Reserved	Reserved	Active_H/L
		1	1	0	0	0	0	0	0
0Dh pg. 32	Interrupt Status	Reserved	Reserved	Reserved	Reserved	ClkErr	Reserved	Ovfl	Undrfl
		0	0	0	0	0	0	0	0
0Eh pg. 33	Interrupt Mask	Reserved	Reserved	Reserved	Reserved	ClkErrM	Reserved	OvflM	UndrflM
		0	0	0	0	0	0	0	0
0Fh pg. 33	Interrupt Mode MSB	Reserved	Reserved	Reserved	Reserved	ClkErr1	Reserved	Ovfl1	Undrfl1
		0	0	0	0	0	0	0	0
10h pg. 33	Interrupt Mode LSB	Reserved	Reserved	Reserved	Reserved	ClkErr0	Reserved	Ovfl0	Undrfl0
		0	0	0	0	0	0	0	0

7. REGISTER DESCRIPTION

7.1 Chip ID - Register 01h

7	6	5	4	3	2	1	0
PART3	PART2	PART1	PART0	REV3	REV2	REV1	REV0

Function:

This register is Read-Only. Bits 7 through 4 are the part number ID, which is 1100b, and the remaining bits (3 through 0) indicate the device revision as shown in [Table 4](#) below.

REV[3:0]	Revision
0000	A1

Table 4. Device Revision

7.2 Power Control - Address 02h

7	6	5	4	3	2	1	0
Freeze	Reserved	Reserved	Reserved	PDN_MIC	PDN_ADC	Reserved	PDN

7.2.1 Freeze (Bit 7)

Function:

This function allows modifications to be made to certain control port bits without the changes taking effect until the Freeze bit is disabled. To make multiple changes to these bits take effect simultaneously, set the Freeze bit, make all changes, then clear the Freeze bit. The bits affected by the Freeze function are listed in [Table 5](#).

Name	Register	Bit(s)
Mute	04h	2
Gain[5:0]	07h	5:0
Gain[5:0]	08h	5:0

Table 5. Freeze-able Bits

7.2.2 Power-Down MIC (Bit 3)

Function:

The microphone preamplifier block will enter a low-power state whenever this bit is set.

7.2.3 Power-Down ADC (Bit 2)

Function:

The ADC pair will remain in a reset state whenever this bit is set.

7.2.4 Power-Down Device (Bit 0)

Function:

The device will enter a low-power state whenever this bit is set. The power-down bit is set by default and must be cleared before normal operation can occur. The contents of the control registers are retained when the device is in power-down.

7.3 ADC Control - Address 04h

7	6	5	4	3	2	1	0
FM1	FM0	Reserved	DIF	Reserved	Mute	HPFFreeze	M/S

7.3.1 Functional Mode (Bits 7:6)

Function:

Selects the required range of sample rates.

FM1	FM0	Mode
0	0	Single-Speed Mode: 8 to 50 kHz sample rates
0	1	Double-Speed Mode: 50 to 100 kHz sample rates
1	0	Quad-Speed Mode: 100 to 200 kHz sample rates
1	1	Reserved

Table 6. Functional Mode Selection

7.3.2 Digital Interface Format (Bit 4)

Function:

The required relationship between LRCK, SCLK and SDOUT is defined by the Digital Interface Format bit. The options are detailed in [Table 7](#) and may be seen in [Figure 3](#) and [Figure 4](#).

DIF	Description	Format	Figure
0	Left-Justified (default)	0	3
1	I ² S	1	4

Table 7. Digital Interface Formats

7.3.3 Mute (Bit 2)

Function:

When this bit is set, the serial audio output of the both channels is muted.

7.3.4 High-Pass Filter Freeze (Bit 1)

Function:

When this bit is set, the internal high-pass filter is disabled. The current DC offset value will be frozen and continue to be subtracted from the conversion result. See [“High-Pass Filter and DC Offset Calibration”](#) on [page 20](#).

7.3.5 Master / Slave Mode (Bit 0)

Function:

This bit selects either master or slave operation for the serial audio port. Setting this bit selects Master Mode, while clearing this bit selects Slave Mode.

7.4 MCLK Frequency - Address 05h

7	6	5	4	3	2	1	0
Reserved	MCLK Freq2	MCLK Freq1	MCLK Freq0	Reserved	Reserved	Reserved	Reserved

7.4.1 Master Clock Dividers (Bits 6:4)

Function:

Sets the frequency of the supplied MCLK signal. See [Table 8](#) for the appropriate settings.

MCLK Divider	MCLK Freq2	MCLK Freq1	MCLK Freq0
÷ 1	0	0	0
÷ 1.5	0	0	1
÷ 2	0	1	0
÷ 3	0	1	1
÷ 4	1	0	0
Reserved	1	0	1
Reserved	1	1	x

Table 8. MCLK Frequency

7.5 PGAOut Control - Address 06h

7	6	5	4	3	2	1	0
Reserved	PGAOut	Reserved	Reserved	Reserved	Reserved	Reserved	Reserved

7.5.1 PGAOut Source Select (Bit 6)

Function:

This bit is used to configure the PGAOut pins to be either high impedance or PGA outputs. Refer to [Table 9](#).

PGAOut	PGAOutA & PGAOutB
0	High Impedance
1	PGA Output

Table 9. PGAOut Source Selection

7.6 Channel B PGA Control - Address 07h

7	6	5	4	3	2	1	0
Reserved	Reserved	Gain5	Gain4	Gain3	Gain2	Gain1	Gain0

7.6.1 Channel B PGA Gain (Bits 5:0)

Function:

See "Channel A PGA Gain (Bits 5:0)" on page 31.

7.7 Channel A PGA Control - Address 08h

7	6	5	4	3	2	1	0
Reserved	Reserved	Gain5	Gain4	Gain3	Gain2	Gain1	Gain0

7.7.1 Channel A PGA Gain (Bits 5:0)

Function:

Sets the gain or attenuation for the ADC input PGA stage. The gain may be adjusted from -12 dB to +12 dB in 0.5 dB steps. The gain bits are in two's complement with the Gain0 bit set for a 0.5 dB step. Register settings outside of the ± 12 dB range are reserved and must not be used. See [Table 10](#) for example settings.

Gain[5:0]	Setting
101000	-12 dB
000000	0 dB
011000	+12 dB

Table 10. Example Gain and Attenuation Settings

7.8 ADC Input Control - Address 09h

7	6	5	4	3	2	1	0
Reserved	Reserved	Reserved	PGASoft	PGAZero	Sel2	Sel1	Sel0

7.8.1 PGA Soft Ramp or Zero Cross Enable (Bits 4:3)

Function:

Soft Ramp Enable

Soft Ramp allows level changes, both muting and attenuation, to be implemented by incrementally ramping, in 1/8 dB steps, from the current level to the new level at a rate of 1 dB per 8 left/right clock periods. See [Table 11](#).

Zero Cross Enable

Zero Cross Enable dictates that signal-level changes, either by attenuation changes or muting, will occur on a signal zero crossing to minimize audible artifacts. The requested level change will occur after a time-out period between 512 and 1024 sample periods (10.7 ms to 21.3 ms at 48 kHz sample rate) if the signal does not encounter a zero crossing. The zero cross function is independently monitored and implemented for each channel. See [Table 11](#).

Soft Ramp and Zero Cross Enable

Soft Ramp and Zero Cross Enable dictate that signal-level changes, either by attenuation changes or muting, will occur in 1/8 dB steps and be implemented on a signal zero crossing. The 1/8 dB level change will occur after a time-out period between 512 and 1024 sample periods (10.7 ms to 21.3 ms at 48 kHz sample rate) if the signal does not encounter a zero crossing. The zero cross function is independently monitored and implemented for each channel. See [Table 11](#).

PGASoft	PGAZeroCross	Mode
0	0	Changes to affect immediately
0	1	Zero Cross enabled
1	0	Soft Ramp enabled
1	1	Soft Ramp and Zero Cross enabled (default)

Table 11. PGA Soft Cross or Zero Cross Mode Selection

7.8.2 Analog Input Selection (Bits 2:0)

Function:

These bits are used to select the input source for the PGA and ADC. Please see [Table 12](#).

Sel2	Sel1	Sel0	PGA/ADC Input
0	0	0	Microphone-Level Inputs (+32 dB Gain Enabled)
0	0	1	Line-Level Input Pair 1
0	1	0	Line-Level Input Pair 2
0	1	1	Line-Level Input Pair 3
1	0	0	Line-Level Input Pair 4
1	0	1	Line-Level Input Pair 5
1	1	0	Line-Level Input Pair 6
1	1	1	Reserved

Table 12. Analog Input Multiplexer Selection

7.9 Active Level Control - Address 0Ch

7	6	5	4	3	2	1	0
Reserved	Reserved	Reserved	Reserved	Reserved	Reserved	Reserved	Active_H/L $\bar{}$

7.9.1 Active High/Low (Bit 0)

Function:

When this bit is set, the INT pin functions as an active high CMOS driver.

When this bit is cleared, the INT pin functions as an active low open drain driver and will require an external pull-up resistor for proper operation.

7.10 Status - Address 0Dh

7	6	5	4	3	2	1	0
Reserved	Reserved	Reserved	Reserved	ClkErr	Reserved	Ovfl	Undrfl

For all bits in this register, a '1' means the associated condition has occurred at least once since the register was last read. A '0' means the associated condition has NOT occurred since the last reading of the register. Status bits that are masked off in the associated mask register will always be '0' in this register. This register defaults to 00h.

7.10.1 Clock Error (Bit 3)

Function:

Indicates the occurrence of a clock error condition.

7.10.2 Overflow (Bit 1)

Function:

Indicates the occurrence of an ADC overflow condition.

7.10.3 Underflow (Bit 0)

Function:

Indicates the occurrence of an ADC underflow condition.

7.11 Status Mask - Address 0Eh

7	6	5	4	3	2	1	0
Reserved	Reserved	Reserved	Reserved	ClkErrM	Reserved	OvfIM	UndrfIM

Function:

The bits of this register serve as a mask for the Status sources found in the register “[Status - Address 0Dh](#)” on page 32. If a mask bit is set to 1, the error is unmasked, meaning that its occurrence will affect the status register. If a mask bit is set to 0, the error is masked, meaning that its occurrence will not affect the status register. The bit positions align with the corresponding bits in the Status register.

7.12 Status Mode MSB - Address 0Fh

7.13 Status Mode LSB - Address 10h

7	6	5	4	3	2	1	0
Reserved	Reserved	Reserved	Reserved	ClkErr1	Reserved	Ovf1	Undrf1
Reserved	Reserved	Reserved	Reserved	ClkErr0	Reserved	Ovf0	Undrf0

Function:

The two Status Mode registers form a 2-bit code for each Status register function. There are three ways to update the Status register in accordance with the status condition. In the Rising-Edge Active Mode, the status bit becomes active on the arrival of the condition. In the Falling-Edge Active Mode, the status bit becomes active on the removal of the condition. In Level-Active Mode, the status bit is active during the condition.

- 00 - Rising edge active
- 01 - Falling edge active
- 10 - Level active
- 11 - Reserved

8. PARAMETER DEFINITIONS

Dynamic Range

The ratio of the rms value of the signal to the rms sum of all other spectral components over the specified bandwidth. Dynamic Range is a signal-to-noise ratio measurement over the specified bandwidth made with a -60 dBFS signal. 60 dB is added to resulting measurement to refer the measurement to full scale. This technique ensures that the distortion components are below the noise level and do not affect the measurement. This measurement technique has been accepted by the Audio Engineering Society, AES17-1991, and the Electronic Industries Association of Japan, EIAJ CP-307. Expressed in decibels.

Total Harmonic Distortion + Noise

The ratio of the rms value of the signal to the rms sum of all other spectral components over the specified bandwidth (typically 10 Hz to 20 kHz), including distortion components. Expressed in decibels. Measured at -1 and -20 dBFS as suggested in AES17-1991 Annex A.

Frequency Response

A measure of the amplitude response variation from 10 Hz to 20 kHz relative to the amplitude response at 1 kHz. Units in decibels.

Interchannel Isolation

A measure of crosstalk between the left and right channels. Measured for each channel at the converter's output with no signal to the input under test and a full-scale signal applied to the other channel. Units in decibels.

Interchannel Gain Mismatch

The gain difference between left and right channels. Units in decibels.

Gain Drift

The change in gain value with temperature. Units in ppm/°C.

9. FILTER PLOTS

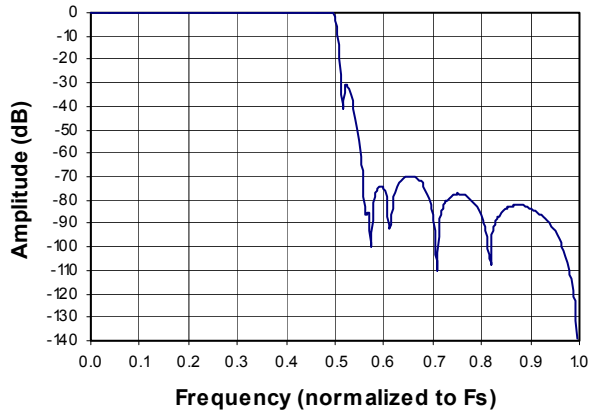

Figure 17. Single-Speed Stopband Rejection

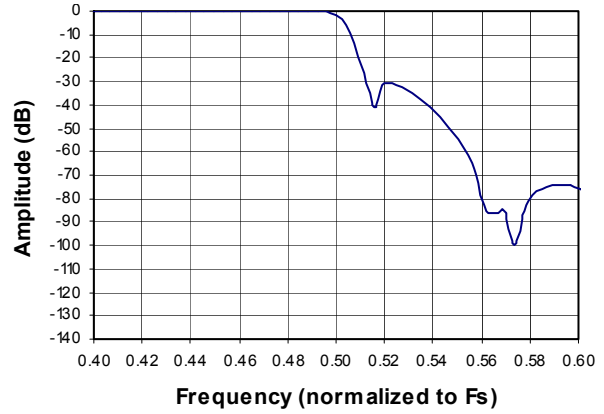

Figure 18. Single-Speed Stopband Rejection

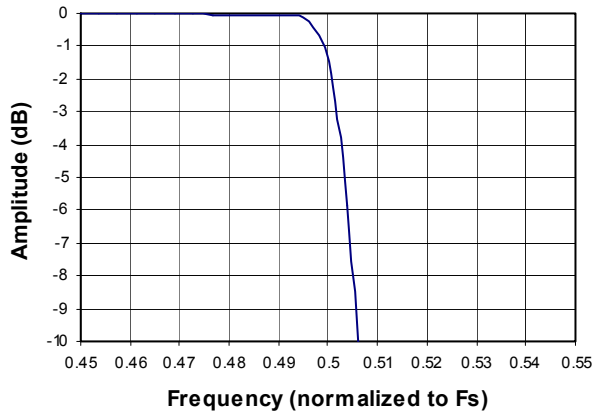

Figure 19. Single-Speed Transition Band (Detail)

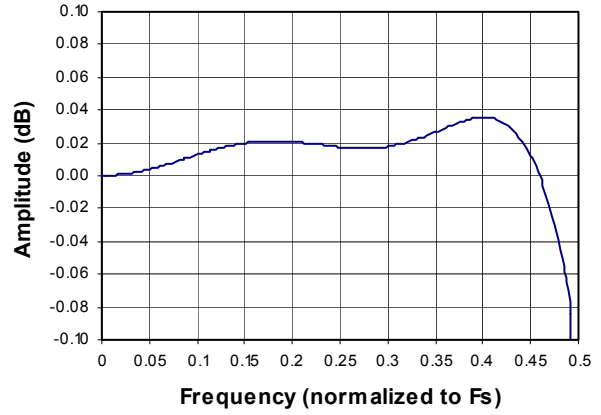

Figure 20. Single-Speed Passband Ripple

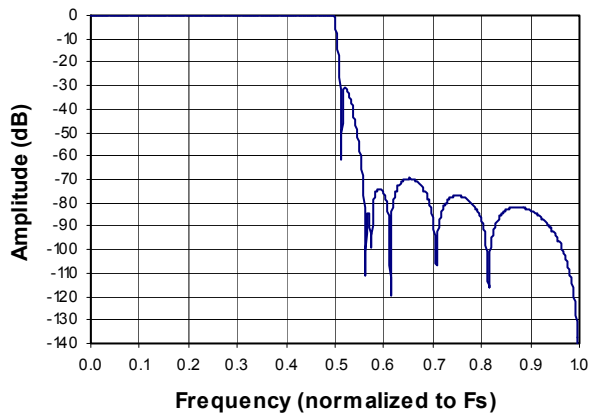

Figure 21. Double-Speed Stopband Rejection

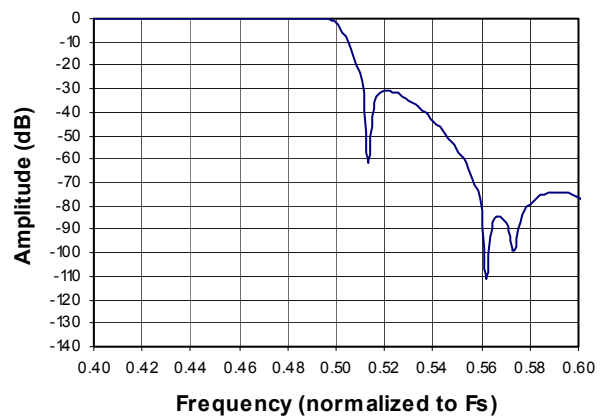

Figure 22. Double-Speed Stopband Rejection

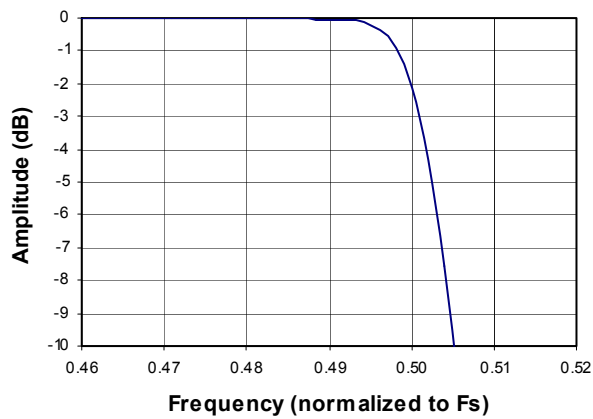

Figure 23. Double-Speed Transition Band (Detail)

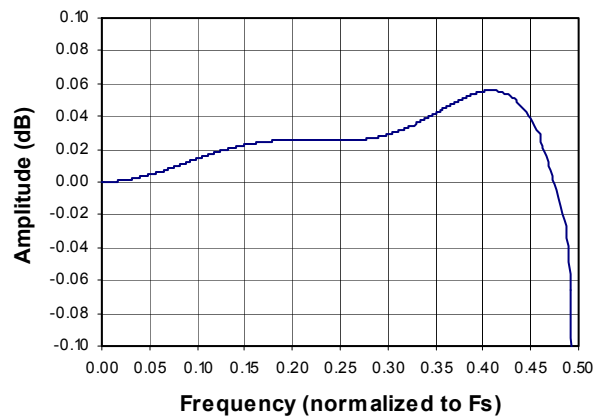

Figure 24. Double-Speed Passband Ripple

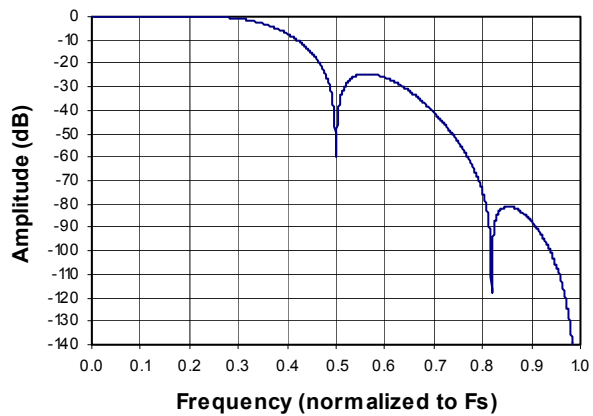

Figure 25. Quad-Speed Stopband Rejection

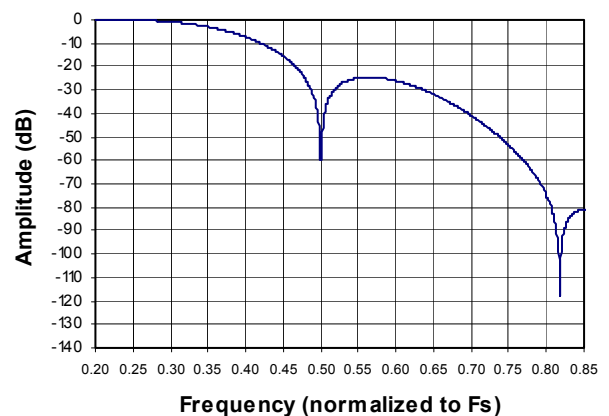

Figure 26. Quad-Speed Stopband Rejection

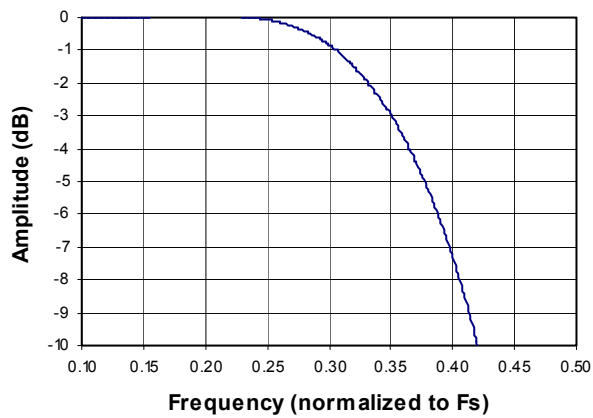

Figure 27. Quad-Speed Transition Band (Detail)

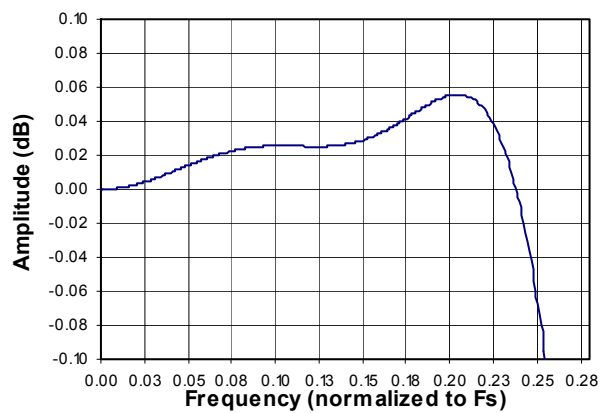
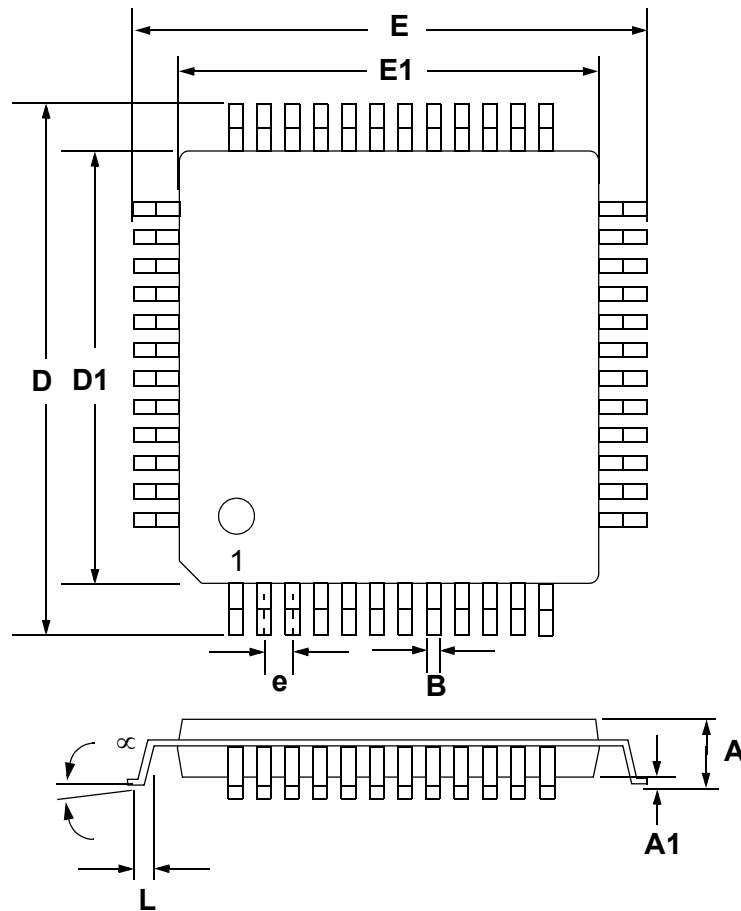

Figure 28. Quad-Speed Passband Ripple

10. PACKAGE DIMENSIONS
48L LQFP PACKAGE DRAWING

DIM	INCHES			MILLIMETERS		
	MIN	NOM	MAX	MIN	NOM	MAX
A	---	0.055	0.063	---	1.40	1.60
A1	0.002	0.004	0.006	0.05	0.10	0.15
B	0.007	0.009	0.011	0.17	0.22	0.27
D	0.343	0.354	0.366	8.70	9.0 BSC	9.30
D1	0.272	0.28	0.280	6.90	7.0 BSC	7.10
E	0.343	0.354	0.366	8.70	9.0 BSC	9.30
E1	0.272	0.28	0.280	6.90	7.0 BSC	7.10
e*	0.016	0.020	0.024	0.40	0.50 BSC	0.60
L	0.018	0.24	0.030	0.45	0.60	0.75
∞	0.000°	4°	7.000°	0.00°	4°	7.00°

* Nominal pin pitch is 0.50 mm

*Controlling dimension is mm.

*JEDEC Designation: MS022

11.THERMAL CHARACTERISTICS AND SPECIFICATIONS

Parameters	Symbol	Min	Typ	Max	Units
Package Thermal Resistance (Note 1)	θ_{JA}	-	48	-	°C/Watt
	θ_{JC}	-	15	-	°C/Watt
Allowable Junction Temperature		-	-	125	°C

1. θ_{JA} is specified according to JEDEC specifications for multi-layer PCBs.

12. ORDERING INFORMATION

Product	Description	Package	Pb-Free	Grade	Temp Range	Container	Order #
CS5346	24-bit, 192 kHz Stereo Audio ADC	48-LQFP	Yes	Commercial	-40° to +85° C	Tray	CS5346-CQZ
						Tape & Reel	CS5346-CQZR
CDB5346	CS5346 Evaluation Board		No	-	-	-	CDB5346

13. REVISION HISTORY

Release	Changes
PP1	-Updated Title -Added text to Section 2. on page 7 -Added V/V representations for PGA and MIC gain specifications -Updated Automotive THD+N and DNR limits -Added reference to CDB5346 in Section 5.6 on page 23
PP2	-Added note 3 and note for AFILTA/AFILTB capacitors in Figure 7.
PP3	-Removed references to automotive grade parts.

Contacting Cirrus Logic Support

For all product questions and inquiries, contact a Cirrus Logic Sales Representative.

To find the one nearest you, go to www.cirrus.com

IMPORTANT NOTICE

"Preliminary" product information describes products that are in production, but for which full characterization data is not yet available. Cirrus Logic, Inc. and its subsidiaries ("Cirrus") believe that the information contained in this document is accurate and reliable. However, the information is subject to change without notice and is provided "AS IS" without warranty of any kind (express or implied). Customers are advised to obtain the latest version of relevant information to verify, before placing orders, that information being relied on is current and complete. All products are sold subject to the terms and conditions of sale supplied at the time of order acknowledgment, including those pertaining to warranty, indemnification, and limitation of liability. No responsibility is assumed by Cirrus for the use of this information, including use of this information as the basis for manufacture or sale of any items, or for infringement of patents or other rights of third parties. This document is the property of Cirrus and by furnishing this information, Cirrus grants no license, express or implied under any patents, mask work rights, copyrights, trademarks, trade secrets or other intellectual property rights. Cirrus owns the copyrights associated with the information contained herein and gives consent for copies to be made of the information only for use within your organization with respect to Cirrus integrated circuits or other products of Cirrus. This consent does not extend to other copying such as copying for general distribution, advertising or promotional purposes, or for creating any work for resale.

CERTAIN APPLICATIONS USING SEMICONDUCTOR PRODUCTS MAY INVOLVE POTENTIAL RISKS OF DEATH, PERSONAL INJURY, OR SEVERE PROPERTY OR ENVIRONMENTAL DAMAGE ("CRITICAL APPLICATIONS"). CIRRUS PRODUCTS ARE NOT DESIGNED, AUTHORIZED OR WARRANTED FOR USE IN PRODUCTS SURGICALLY IMPLANTED INTO THE BODY, AUTOMOTIVE SAFETY OR SECURITY DEVICES, LIFE SUPPORT PRODUCTS OR OTHER CRITICAL APPLICATIONS. INCLUSION OF CIRRUS PRODUCTS IN SUCH APPLICATIONS IS UNDERSTOOD TO BE FULLY AT THE CUSTOMER'S RISK AND CIRRUS DISCLAIMS AND MAKES NO WARRANTY, EXPRESS, STATUTORY OR IMPLIED, INCLUDING THE IMPLIED WARRANTIES OF MERCHANTABILITY AND FITNESS FOR PARTICULAR PURPOSE, WITH REGARD TO ANY CIRRUS PRODUCT THAT IS USED IN SUCH A MANNER. IF THE CUSTOMER OR CUSTOMER'S CUSTOMER USES OR PERMITS THE USE OF CIRRUS PRODUCTS IN CRITICAL APPLICATIONS, CUSTOMER AGREES, BY SUCH USE, TO FULLY INDEMNIFY CIRRUS, ITS OFFICERS, DIRECTORS, EMPLOYEES, DISTRIBUTORS AND OTHER AGENTS FROM ANY AND ALL LIABILITY, INCLUDING ATTORNEYS' FEES AND COSTS, THAT MAY RESULT FROM OR ARISE IN CONNECTION WITH THESE USES.

Cirrus Logic, Cirrus, and the Cirrus Logic logo designs are trademarks of Cirrus Logic, Inc. All other brand and product names in this document may be trademarks or service marks of their respective owners.

I²C is a trademark of Philips Semiconductor.

SPI is a trademark of Motorola, Inc.

Mouser Electronics

Authorized Distributor

Click to View Pricing, Inventory, Delivery & Lifecycle Information:

[Cirrus Logic:](#)

[CDB5346](#) [CS5346-CQZ](#) [CS5346-CQZR](#)

Компания «Life Electronics» занимается поставками электронных компонентов импортного и отечественного производства от производителей и со складов крупных дистрибьюторов Европы, Америки и Азии.

С конца 2013 года компания активно расширяет линейку поставок компонентов по направлению коаксиальный кабель, кварцевые генераторы и конденсаторы (керамические, пленочные, электролитические), за счёт заключения дистрибьюторских договоров

Мы предлагаем:

- Конкуренеспособные цены и скидки постоянным клиентам.
- Специальные условия для постоянных клиентов.
- Подбор аналогов.
- Поставку компонентов в любых объемах, удовлетворяющих вашим потребностям.
- Приемлемые сроки поставки, возможна ускоренная поставка.
- Доставку товара в любую точку России и стран СНГ.
- Комплексную поставку.
- Работу по проектам и поставку образцов.
- Формирование склада под заказчика.
- Сертификаты соответствия на поставляемую продукцию (по желанию клиента).
- Тестирование поставляемой продукции.
- Поставку компонентов, требующих военную и космическую приемку.
- Входной контроль качества.
- Наличие сертификата ISO.

В составе нашей компании организован Конструкторский отдел, призванный помогать разработчикам, и инженерам.

Конструкторский отдел помогает осуществить:

- Регистрацию проекта у производителя компонентов.
- Техническую поддержку проекта.
- Защиту от снятия компонента с производства.
- Оценку стоимости проекта по компонентам.
- Изготовление тестовой платы монтаж и пусконаладочные работы.



Тел: +7 (812) 336 43 04 (многоканальный)

Email: org@lifeelectronics.ru