

Thin Film Pyroelectric Linear 128 Element Line Sensor Array

With Integrated Read-Out Electronics

Introduction

The Pyreos line sensor array utilises our unique thin-film pyroelectric PZT material to offer class leading resolution and performance across a wide wavelength range at a very affordable price. The ASIC readout electronics output is a multiplexed, amplified and filtered analogue signal for each sensor element. The sensor is housed in a low profile hermetic metal package along with a temperature sensor, and is fitted with a linear variable filter or a broadband filter.

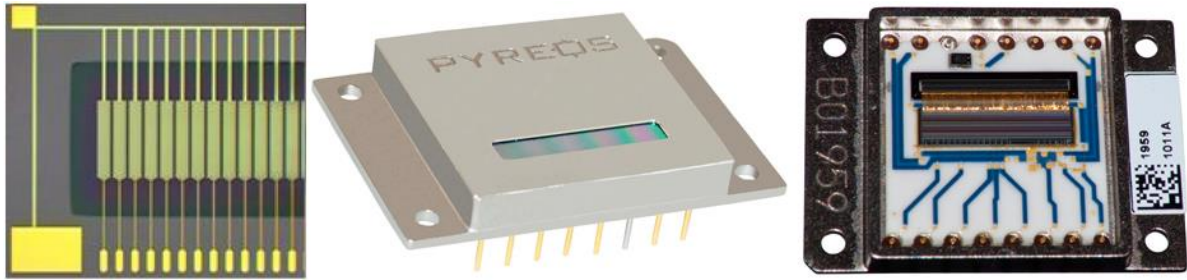

Product Features

Wavelength range	0.1 to 100 μm ¹
Operating temperature	Un-cooled operation
Number of pixels	128 sensor elements
Pixel sizes	60 μm x 500 μm ; 100 μm pitch
Pixel operability	96% with no more than 2 bad in any 10
Dynamic range	>75 dB
Scan speed	10-1000 Hz

Applications

General IR spectroscopy	Portable, robust spectral engines
Lubricating oil monitoring	Quality, wear, adulteration,
Foodstuffs	Constitution, adulteration
Process monitoring	Wind turbine, petrochemical, pharmaceutical
Temperature measurement	Non-contact line scanning measurement
Imaging	Line scanning

¹Choice of filter windows available

Filters Available

Part Number	PY0722	PY0738	PY1499
Filter Material	Silicon	LVF	LVF
Filter type	Broadband	Linear Variable filter	Linear Variable Filter
Transmission wavelength (μm)	-	5.5 to 11 (CWL 2%)	2.5 to 5 (CWL 2%)
Transmission wavenumbers (cm^{-1})	-	1818 to 909	4000 to 2000

Please note: the information contained in this document is subject to change without further notification. Pyreos reserves the right to alter the performance and any resulting specification. Pyreos may choose not to supply any engineering sample devices as a commercial product. No responsibility is accepted for any consequential loss incurred. Pyreos Ltd, SMC, Alexander Crum Brown Road, Edinburgh EH9 3FF, UK. Tel: +441316507009, www.pyreos.com

Package Information

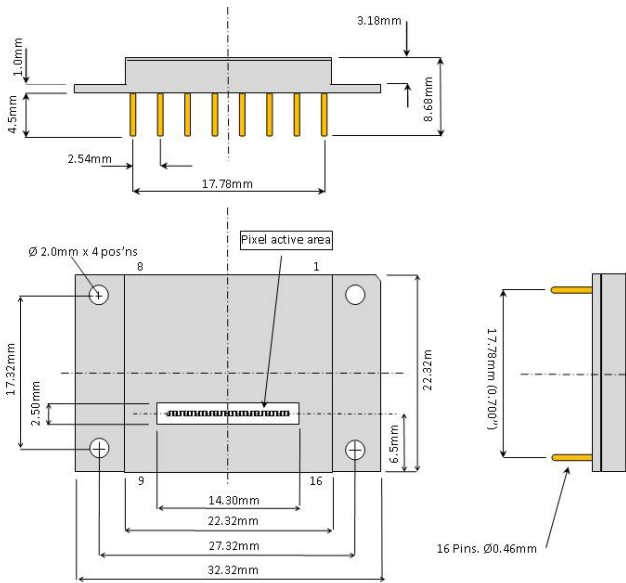

No.	Name	Comment
1.	CLK	Input clock CLK (trigger on rising edge)
2.	RES	Input clock RES (active low)
3.	VVR	Input clock VDR (active high)
4.	VDR	Input clock VDR (active high)
5.	VSH	Input clock VSH (active high)
6.	VD2	Operating voltage (+2.5 V)
7.	AVDD	Operating voltage (+5 V)
8.	VD2	Operating voltage (+2.5 V)
9.	OUT	Analogue signal output
10.	AGND	Ground
11.	n.c.	Not connected
12.	T+	Temperature sensor
13.	T-	Temperature sensor
14.	case	Case
15.	DGND	Ground
16.	DVDD	Operating voltage (+5 V)

Note: Pixel 1 is nearest pin 1 of the device.

Circuit Diagram

The amplification circuit consists of low-noise preamplifiers for each individual sensor elements, analogue switches and an output amplifier. The pre-amplifiers transform the signal charges measured at each sensor element into a conditioned voltage. The amplified signal is then passed to sample and hold, multiplexer output buffer for the read-out process. The digital inputs are CMOS compatible. A 10k NTC thermistor is integrated within the package to monitor the line sensor temperature.

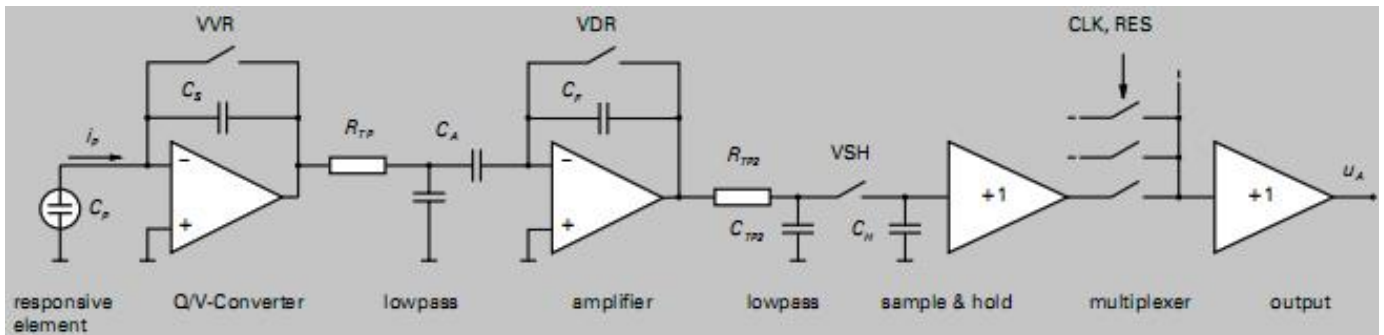

Thermistor is NTC, 1%. For more details check ERTJZEG103FA Datasheet on Industrial Panasonic website.

Order Information

Please quote PYxxxx for your desired option of this product. Contact: sales@pyreos.com

Clock Parameters

Similar to all pyroelectric sensors, the Pyreos thin-film pyroelectric line sensor array responds to and detects a change in infrared radiation intensity. It therefore requires a pulsed source of infrared radiation for measurement purposes.

Parameter ¹	Relative Value	Min. Values	Recommended Value
Chopping Frequency ² f_{ch}		10 Hz	128 Hz
Read-out Clock CLK $f_{CLK} = 2 * f_{ch} * 268$	$1/t_{CLK}$	5.36 KHz	69 KHz
Reset clock low-impulse duration t_{RES}	$1/2 t_{CLK}$	1.8 μs	7.5 μs
Clock VVR high-impulse duration t_{VVR}	$2 t_{CLK}$	7.5 μs	30 μs
Clock VDR high-impulse duration t_{VDR}	$28 t_{CLK}$	200 μs	400 μs
Clock VSH high-impulse duration t_{VSH}	$1 t_{CLK}$	3.5 μs	15 μs

Maximum Settling Time at output t_{out} is 1 μ second

¹ All values for $VDD = 5 V$, $VD2 = 2.5V$

² $t_{Ch low} = t_{Ch high}$

Clock Diagram

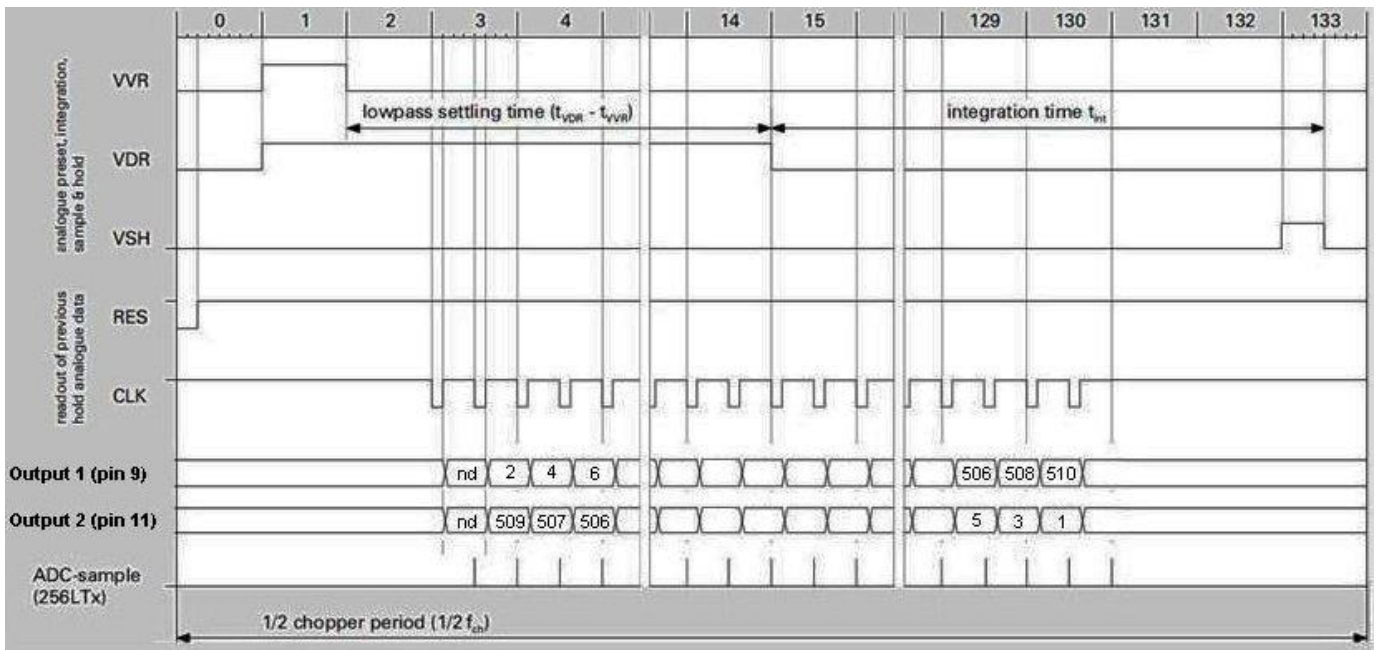

Компания «Life Electronics» занимается поставками электронных компонентов импортного и отечественного производства от производителей и со складов крупных дистрибьюторов Европы, Америки и Азии.

С конца 2013 года компания активно расширяет линейку поставок компонентов по направлению коаксиальный кабель, кварцевые генераторы и конденсаторы (керамические, пленочные, электролитические), за счёт заключения дистрибьюторских договоров

Мы предлагаем:

- Конкурентоспособные цены и скидки постоянным клиентам.
- Специальные условия для постоянных клиентов.
- Подбор аналогов.
- Поставку компонентов в любых объемах, удовлетворяющих вашим потребностям.
- Приемлемые сроки поставки, возможна ускоренная поставка.
- Доставку товара в любую точку России и стран СНГ.
- Комплексную поставку.
- Работу по проектам и поставку образцов.
- Формирование склада под заказчика.
- Сертификаты соответствия на поставляемую продукцию (по желанию клиента).
- Тестирование поставляемой продукции.
- Поставку компонентов, требующих военную и космическую приемку.
- Входной контроль качества.
- Наличие сертификата ISO.

В составе нашей компании организован Конструкторский отдел, призванный помогать разработчикам, и инженерам.

Конструкторский отдел помогает осуществить:

- Регистрацию проекта у производителя компонентов.
- Техническую поддержку проекта.
- Защиту от снятия компонента с производства.
- Оценку стоимости проекта по компонентам.
- Изготовление тестовой платы монтаж и пусконаладочные работы.



Тел: +7 (812) 336 43 04 (многоканальный)

Email: org@lifeelectronics.ru