

Card Edge Connector for PCI Express Applications

DESCRIPTION

Tyco Electronics Card Edge Connector for PCI Express applications is a 1mm centerline card edge product designed to meet PCI SIG requirements for PCI Express architecture. PCI Express architecture is a high performance point to point full duplex I/O Bus.

APPLICATIONS

- Serial Bus for Graphics Cards and I/O Client Cards for applications requiring higher speeds than the popular PCI Bus.
- Computers, both Desktop and Server, along with Telecommunication Switches and Routers.

KEY FEATURES

- Available:
 - In all standard sizes: (36 pins), x4 (64 pins), x8 (98 pins), and x16 (164pins)
 - With plastic locating posts or metal hold downs
 - With integrated retention mechanism in x16 size
 - In straddle mount configuration

- In right angle configuration
- Three tail lengths: 2.3mm, 3.1mm, and 5.6mm
- Gold Flash, 15 Gold, and 30 Gold plating options
- RoHS Compliant

TECHNICAL DOCUMENTS

- Product Specification
 - 108-5847 (1612163, 1746220, & 1761465)
 - 108-57375 (1775800 & 1775801)
 - 108-57351 (1734857)
- Test Reports
 - 501-5453 (1612163, 1746220, & 1761465)
 - 501-57406 (1775800 & 1775801)
 - 501-57490 (1734857)

RATINGS

Operating Temperature:	-40°C to +85°C
Durability:	50 cycles
Current Rating:	1.1A
Voltage Rating:	50 VAC

FOR MORE INFORMATION

John Larkin, Product Manager

Phone: 1-717-592-2074

E-mail: jtllarkin@tycoelectronics.com

Technical Support

Internet: <http://www.tycoelectronics.com>

USA: 1-800-522-6752

Canada: 1-905-470-4425

UK: 44-141-810-8967

Japan: 81-44-844-8013

BASE PART NUMBERS*

- 1612163-X - with Plastic Locating Posts
- 1775800-X - with Metal Hold Downs (color - white)
- 1775801-X - with Metal Hold Downs (color - black)
- 1746220-X - with Integrated Retention Mechanism
- 1734857-X - Straddle Mount
- 1761465-X - Right Angle

*For specific part numbers, request customer drawing

PRODUCT DIMENSIONS - VERTICAL WITH PLASTIC LOCATING POST

1612163-X

Number of Positions	Dim A	Dim C	Dim N
36	25	9.15	6
64	39	23.15	20
98	56	40.15	37
164	89	73.15	70

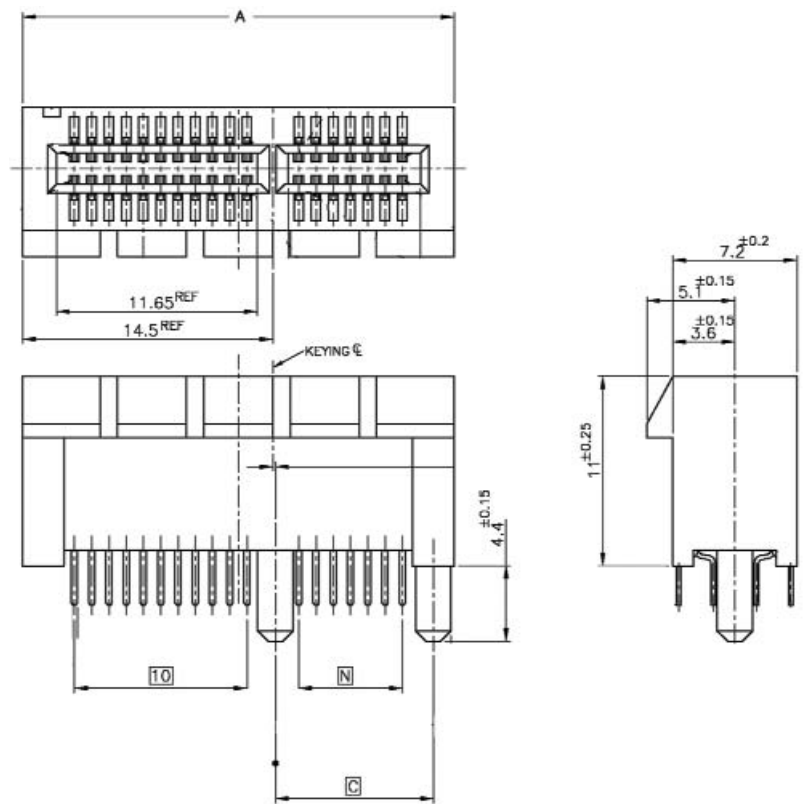

Note: Part Numbers are RoHS Compliant.

PCI Express and PCI SIG are registered trademarks of the PCI-SIG Corporation.

PRODUCT DIMENSIONS- VERTICAL WITH METAL HOLD DOWNS

1775800-X (Color: White)
1775801-X (Color: Black)

Number of Positions	Dim A	Dim C	Dim D
36	25	9.15	6
64	39	23.15	20
98	56	40.15	37
164	89	73.15	70

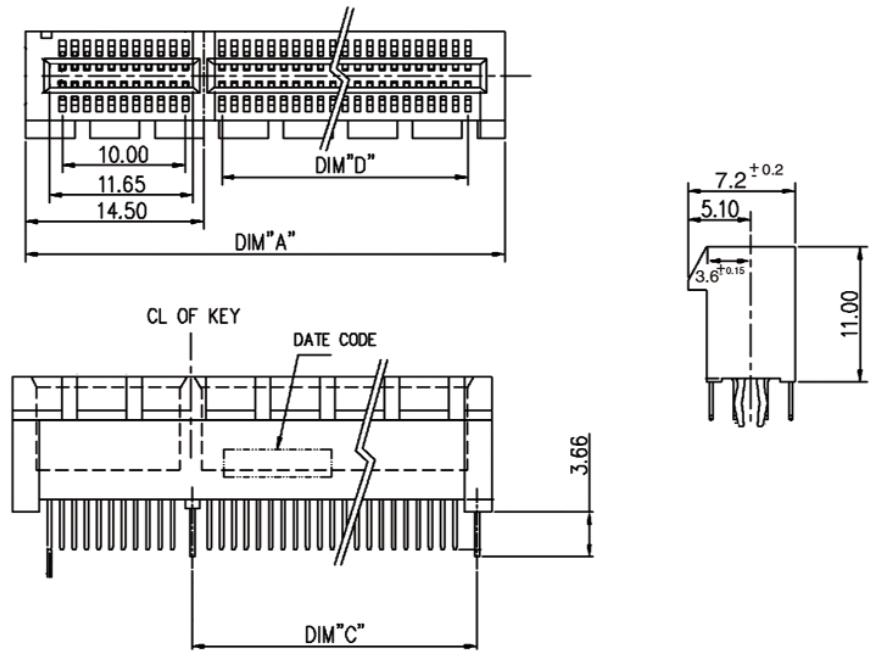

PRODUCT DIMENSIONS- VERTICAL WITH INTEGRATED RETENTIONS

1746220-X

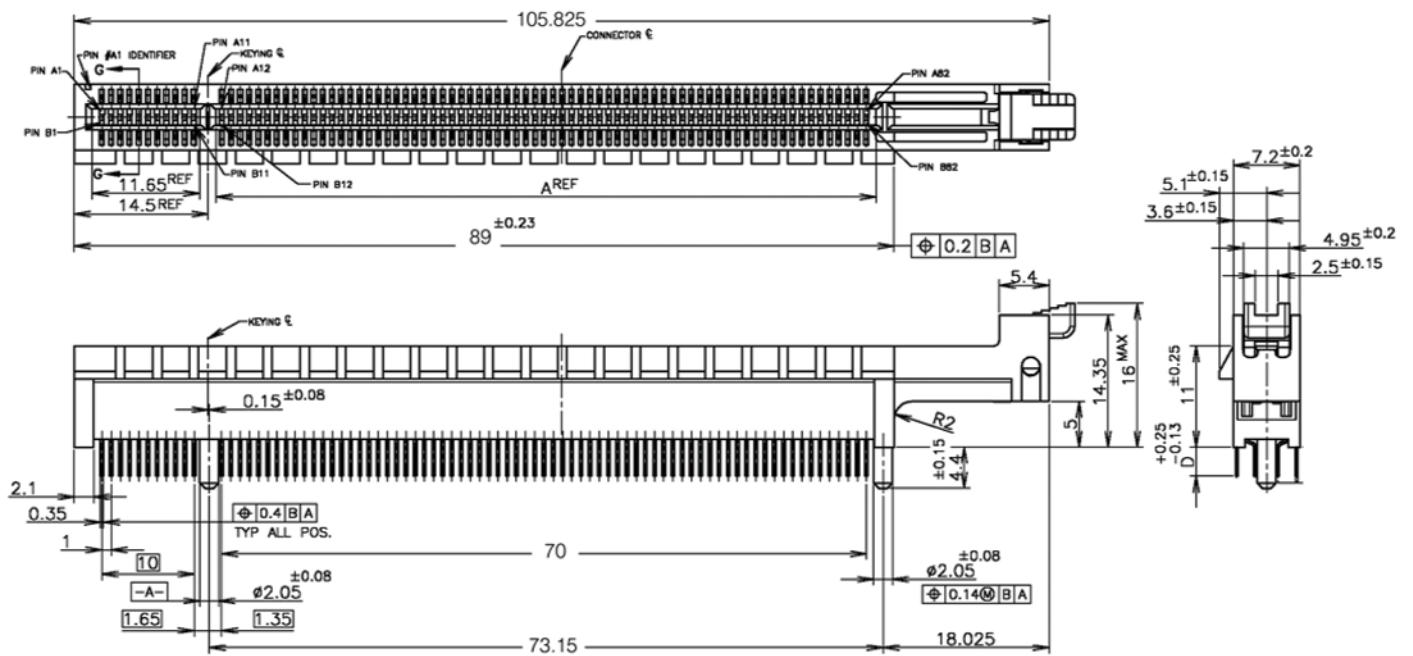

Note: Part Numbers are RoHS Compliant.

PCI Express and PCI SIG are registered trademarks of the PCI-SIG Corporation.

Card Edge Connectors for PCI Express Applications

PRODUCT DIMENSIONS- STRADDLE MOUNT

1734857-X

Number of Positions	Dim A	Dim C	Dim N
36	25	9.15	6
64	39	23.15	20
98	56	40.15	37
164	89	73.15	70

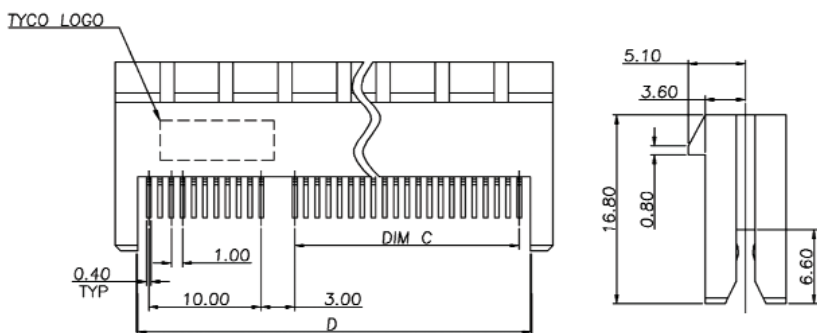
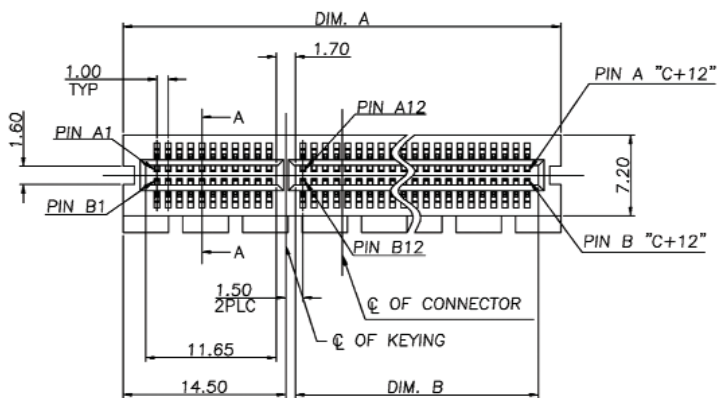

PRODUCT DIMENSIONS- RIGHT ANGLE

1761465-X

Number of Positions	Dim A
36	25
64	39
98	56
164	89
280	147

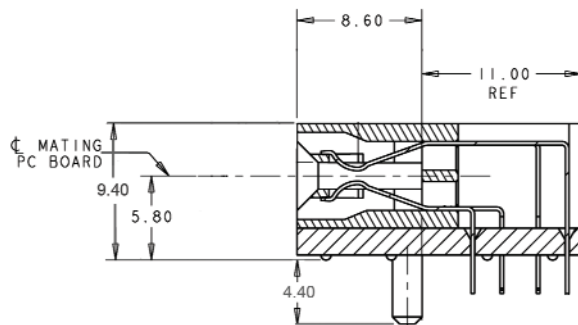
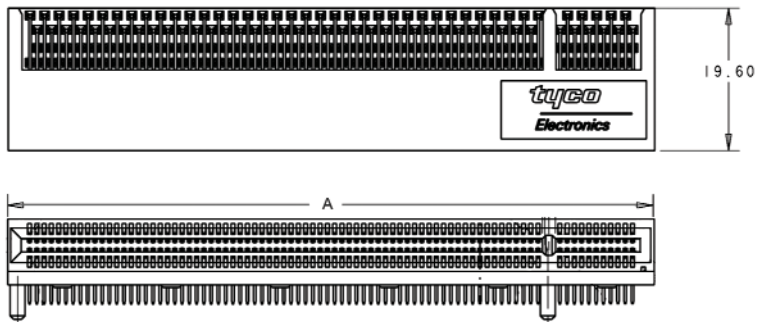

Note: Part Numbers are RoHS Compliant.

PCI Express and PCI SIG are registered trademarks of the PCI-SIG Corporation.

Restriction on the use of Hazardous Substances (RoHS)

At Tyco Electronics, we're ready to support your RoHS requirements. We've assessed more than 1.5 million end items/components for RoHS compliance, and issued new part numbers where any change was required to eliminate the restricted materials. Part numbers in this catalog are identified as:

RoHS Compliant — Part numbers in this catalog are RoHS Compliant, unless marked otherwise. These products comply with European Union Directive 2002/95/EC as amended 1 January 2006 that restricts the use of lead, mercury, cadmium, hexavalent chromium, PBB, and PBDE in certain electrical and electronic products sold into the EU as of 1 July 2006.

NOTE: For purposes of this Catalog, included within the definition of RoHS Compliant are products that are clearly "Out of Scope" of the RoHS Directive such as hand tools and other non-electrical accessories.

NOTE: Information regarding RoHS compliance is provided based on reasonable inquiry of our suppliers and represents our current actual knowledge based on the information provided by our suppliers. This information is subject to change. For latest compliance status, refer to our website referenced at right.

Getting the Information You Need

Our comprehensive on-line RoHS Customer Support Center provides a forum to answer your questions and support your RoHS needs. A RoHS FAQ (Frequently Asked Questions) is available with links to more detailed information. You can also submit RoHS questions and receive a response within 24 hours during a normal work week.

The Support Center also provides:

- Cross-Reference from Non-compliant to Compliant Products
- Ability to browse RoHS Compliant Products in our on-line catalog
- Downloadable Technical Data Customer Information Presentation
- More detailed information regarding the definitions used above
- So whatever your questions when it comes to RoHS, we've got the answers at www.tycoelectronics.com/leadfree



Disclaimer

While Tyco Electronics Corporation and its affiliates referenced herein ("Tyco Electronics") have made every reasonable effort to ensure the accuracy of the information in this catalog, Tyco Electronics does not guarantee that it is error free, nor does Tyco Electronics make any other representation, warranty or guarantee that the information is accurate, correct reliable or current.

Tyco Electronics reserves the right to make any adjustments to the information contained herein at any time without notice. Tyco Electronics expressly disclaims all implied warranties regarding the information contained herein, including, but not limited to, any implied warranties of merchantability or fitness for a particular purpose. Tyco Electronics' only obligations are those in the Tyco Electronics Standard Terms and Conditions of Sale, and in no case will Tyco Electronics be responsible for any incidental, indirect, or consequential damages arising from the sale, resale, or misuse of its products. Users should independently evaluate the suitability of, and test each product for, their application.

Компания «Life Electronics» занимается поставками электронных компонентов импортного и отечественного производства от производителей и со складов крупных дистрибьюторов Европы, Америки и Азии.

С конца 2013 года компания активно расширяет линейку поставок компонентов по направлению коаксиальный кабель, кварцевые генераторы и конденсаторы (керамические, пленочные, электролитические), за счёт заключения дистрибьюторских договоров

Мы предлагаем:

- Конкурентоспособные цены и скидки постоянным клиентам.
- Специальные условия для постоянных клиентов.
- Подбор аналогов.
- Поставку компонентов в любых объемах, удовлетворяющих вашим потребностям.
- Приемлемые сроки поставки, возможна ускоренная поставка.
- Доставку товара в любую точку России и стран СНГ.
- Комплексную поставку.
- Работу по проектам и поставку образцов.
- Формирование склада под заказчика.
- Сертификаты соответствия на поставляемую продукцию (по желанию клиента).
- Тестирование поставляемой продукции.
- Поставку компонентов, требующих военную и космическую приемку.
- Входной контроль качества.
- Наличие сертификата ISO.

В составе нашей компании организован Конструкторский отдел, призванный помогать разработчикам, и инженерам.

Конструкторский отдел помогает осуществить:

- Регистрацию проекта у производителя компонентов.
- Техническую поддержку проекта.
- Защиту от снятия компонента с производства.
- Оценку стоимости проекта по компонентам.
- Изготовление тестовой платы монтаж и пусконаладочные работы.



Тел: +7 (812) 336 43 04 (многоканальный)

Email: org@lifeelectronics.ru