

Description

The 9DBV0941 is a member of IDT's Full-Featured PCIe family. The device has 9 output enables for clock management, and 3 selectable SMBus addresses. It has integrated terminations for direct connection to 100Ω transmission lines.

Recommended Application

PCIe Gen1–3 clock distribution in Storage, Networking, Compute, Consumer

Output Features

- 9 1–200MHz Low-Power (LP) HCSL DIF pairs with $Z_o = 100\Omega$
- Easy AC-coupling to other logic families, see IDT application note [AN-891](#)

Key Specifications

- *Additive* cycle-to-cycle jitter < 5ps
- Output-to-output skew < 60ps
- *Additive* phase jitter is < 100fs rms for PCIe Gen3
- *Additive* phase jitter < 300fs rms (12kHz-20MHz at 125MHz)

Block Diagram

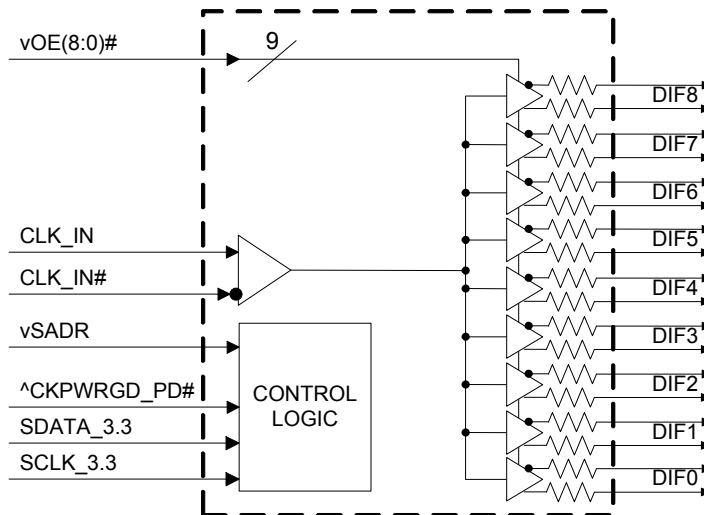

Features/Benefits

- 100Ω direct connect; saves 36 resistors and 62mm^2 compared to standard HCSL
- 53mW typical power consumption; eliminates thermal concerns
- Outputs can optionally be supplied from any voltage between 1.05V and 1.8V; maximum power savings
- $OE\#$ pins; support DIF power management
- HCSL-compatible differential input; can be driven by common clock sources
- SMBus-selectable features allow optimization to customer requirements
 - Slew rate for each output; allows tuning for various line lengths
 - Differential output amplitude; allows tuning for various application environments
- 1MHz to 200MHz operating frequency
- 3.3V tolerant SMBus interface works with legacy controllers
- Selectable SMBus addresses; multiple devices can easily share an SMBus segment
- Device contains default configuration; SMBus interface not required for device operation
- 6 x 6 mm 48-VFQFPN; minimal board space

Pin Configuration

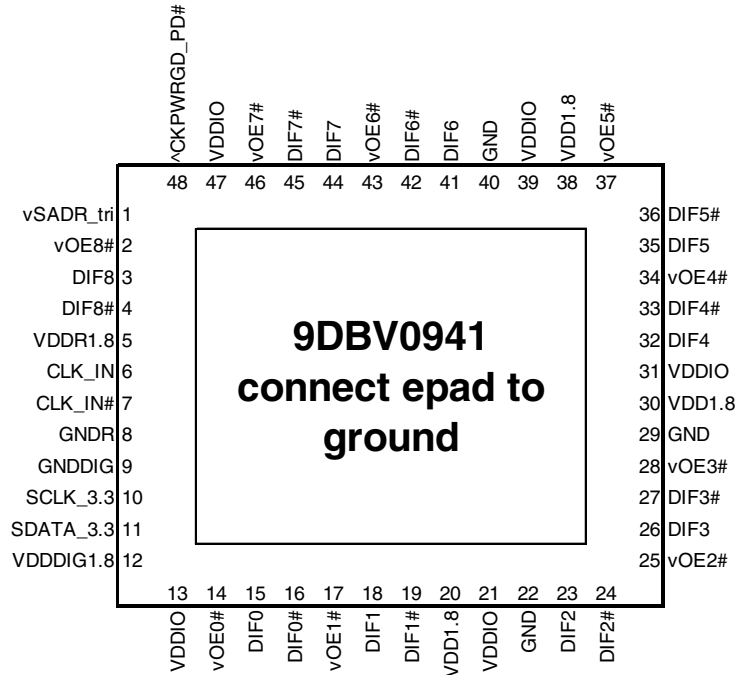

48-pin VFQFPN, 6x6 mm, 0.4mm pitch

- ^v prefix indicates internal 120KOhm pull up *AND* pull down resistor (biased to VDD/2)
- v prefix indicates internal 120KOhm pull down resistor
- ^ prefix indicates internal 120KOhm pull up resistor

SMBus Address Selection Table

	SADR	Address	+ Read/Write bit
State of SADR on first application of CKPWRGD_PD#	0	1101011	x
	M	1101100	x
	1	1101101	x

Power Management Table

CKPWRGD_PD#	CLK_IN	SMBus OEx bit	OEx# Pin	DIFx	
				True O/P	Comp. O/P
0	X	X	X	Low	Low
1	Running	0	X	Low	Low
1	Running	1	0	Running	Running
1	Running	1	1	Low	Low

Power Connections

Pin Number			Description
VDD	VDDIO	GND	
5		8	Input receiver analog
12		9	Digital power
20,30,31,38	13,21,31,39,47	22,29,40	DIF outputs

Pin Descriptions

PIN #	PIN NAME	TYPE	DESCRIPTION
1	vSADR_tri	LATCHED IN	Tri-level latch to select SMBus Address. It has an internal 120kohm pull down resistor. See SMBus Address Selection Table.
2	vOE8#	IN	Active low input for enabling output 8. This pin has an internal 120kohm pull-down. 1 = disable outputs, 0 = enable outputs.
3	DIF8	OUT	Differential true clock output.
4	DIF8#	OUT	Differential complementary clock output.
5	VDDR1.8	PWR	Power supply for differential input clock (receiver). This VDD should be treated as an analog power rail and filtered appropriately. Nominally 1.8V.
6	CLK_IN	IN	True input for differential reference clock.
7	CLK_IN#	IN	Complementary input for differential reference clock.
8	GNDR	GND	Analog ground pin for the differential input (receiver).
9	GNDDIG	GND	Ground pin for digital circuitry.
10	SCLK_3.3	IN	Clock pin of SMBus circuitry, 3.3V tolerant.
11	SDATA_3.3	I/O	Data pin for SMBus circuitry, 3.3V tolerant.
12	VDDDIG1.8	PWR	1.8V digital power (dirty power).
13	VDDIO	PWR	Power supply for differential outputs.
14	vOE0#	IN	Active low input for enabling output 0. This pin has an internal 120kohm pull-down. 1 = disable outputs, 0 = enable outputs.
15	DIF0	OUT	Differential true clock output.
16	DIF0#	OUT	Differential complementary clock output.
17	vOE1#	IN	Active low input for enabling output 1. This pin has an internal 120kohm pull-down. 1 = disable outputs, 0 = enable outputs.
18	DIF1	OUT	Differential true clock output.
19	DIF1#	OUT	Differential complementary clock output.
20	VDD1.8	PWR	Power supply, nominally 1.8V.
21	VDDIO	PWR	Power supply for differential outputs.
22	GND	GND	Ground pin.
23	DIF2	OUT	Differential true clock output.
24	DIF2#	OUT	Differential complementary clock output.
25	vOE2#	IN	Active low input for enabling output 2. This pin has an internal 120kohm pull-down. 1 = disable outputs, 0 = enable outputs.
26	DIF3	OUT	Differential true clock output.
27	DIF3#	OUT	Differential complementary clock output.
28	vOE3#	IN	Active low input for enabling output 3. This pin has an internal 120kohm pull-down. 1 = disable outputs, 0 = enable outputs.
29	GND	GND	Ground pin.
30	VDD1.8	PWR	Power supply, nominally 1.8V.
31	VDDIO	PWR	Power supply for differential outputs.
32	DIF4	OUT	Differential true clock output.
33	DIF4#	OUT	Differential complementary clock output.
34	vOE4#	IN	Active low input for enabling output 4. This pin has an internal 120kohm pull-down. 1 = disable outputs, 0 = enable outputs.
35	DIF5	OUT	Differential true clock output.

Pin Descriptions (cont.)

PIN #	PIN NAME	TYPE	DESCRIPTION
36	DIF5#	OUT	Differential complementary clock output.
37	vOE5#	IN	Active low input for enabling output 5. This pin has an internal 120kohm pull-down. 1 = disable outputs, 0 = enable outputs.
38	VDD1.8	PWR	Power supply, nominally 1.8V.
39	VDDIO	PWR	Power supply for differential outputs.
40	GND	GND	Ground pin.
41	DIF6	OUT	Differential true clock output.
42	DIF6#	OUT	Differential complementary clock output.
43	vOE6#	IN	Active low input for enabling output 6. This pin has an internal 120kohm pull-down. 1 = disable outputs, 0 = enable outputs.
44	DIF7	OUT	Differential true clock output.
45	DIF7#	OUT	Differential complementary clock output.
46	vOE7#	IN	Active low input for enabling output 7. This pin has an internal 120kohm pull-down. 1 = disable outputs, 0 = enable outputs.
47	VDDIO	PWR	Power supply for differential outputs.
48	^CKPWRGD_PD#	IN	Input notifies device to sample latched inputs and start up on first high assertion. Low enters Power Down Mode, subsequent high assertions exit Power Down Mode. This pin has internal 120kohm pull-up resistor.
49	EPAD	GND	Connect epad to ground.

Test Loads

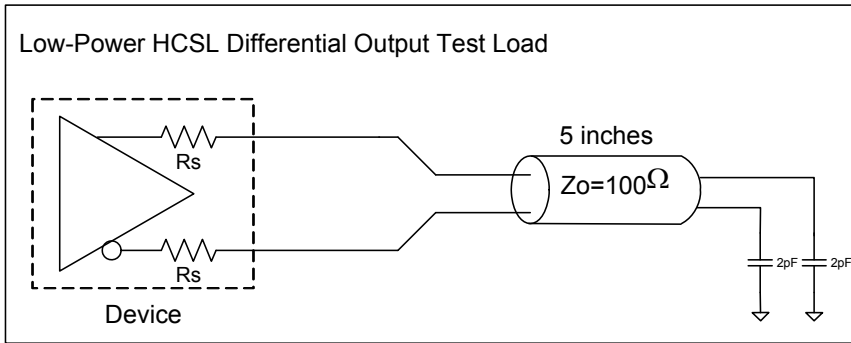

Alternate Terminations

The 9DBV0941 can easily drive LVPECL, LVDS, and CML logic. See [“AN-891 Driving LVPECL, LVDS, and CML Logic with IDT’s “Universal” Low-Power HCSL Outputs”](#) for details.

Absolute Maximum Ratings

Stresses above the ratings listed below can cause permanent damage to the 9DBV0941. These ratings, which are standard values for IDT commercially rated parts, are stress ratings only. Functional operation of the device at these or any other conditions above those indicated in the operational sections of the specifications is not implied. Exposure to absolute maximum rating conditions for extended periods can affect product reliability. Electrical parameters are guaranteed only over the recommended operating temperature range.

PARAMETER	SYMBOL	CONDITIONS	MIN	TYP	MAX	UNITS	NOTES
Supply Voltage	VDDx	Applies to VDD, VDDA and VDDIO	-0.5		2.5	V	1,2
Input Voltage	V _{IN}		-0.5		V _{DD} +0.5	V	1,3
Input High Voltage, SMBus	V _{IHSMB}	SMBus clock and data pins			3.6	V	1
Storage Temperature	T _s		-65		150	°C	1
Junction Temperature	T _j				125	°C	1
Input ESD Protection	ESD prot	Human Body Model	2000			V	1

¹ Guaranteed by design and characterization, not 100% tested in production.

² Operation under these conditions is neither implied nor guaranteed.

³ Not to exceed 2.5V.

Electrical Characteristics—Clock Input Parameters

T_A = T_{COM} or T_{IND}; Supply voltages per normal operation conditions; see Test Loads for loading conditions

PARAMETER	SYMBOL	CONDITIONS	MIN	TYP	MAX	UNITS	NOTES
Input Crossover Voltage - DIF_IN	V _{CROSS}	Cross over voltage	150		900	mV	1
Input Swing - DIF_IN	V _{SWING}	Differential value	300			mV	1
Input Slew Rate - DIF_IN	dv/dt	Measured differentially	0.4		8	V/ns	1,2
Input Leakage Current	I _{IN}	V _{IN} = V _{DD} , V _{IN} = GND	-5		5	μA	
Input Duty Cycle	d _{tin}	Measurement from differential waveform	40		60	%	1
Input Jitter - Cycle to Cycle	J _{DIFIN}	Differential measurement	0		125	ps	1

¹ Guaranteed by design and characterization, not 100% tested in production.

² Slew rate measured through +/-75mV window centered around differential zero.

Electrical Characteristics–Input/Supply/Common Parameters–Normal Operating Conditions

TA = T_{COM} or T_{IND}; Supply voltages per normal operation conditions; see Test Loads for loading conditions

PARAMETER	SYMBOL	CONDITIONS	MIN	TYP	MAX	UNITS	NOTES
Supply Voltage	VDDx	Supply voltage for core and analog	1.7	1.8	1.9	V	
Output Supply Voltage	VDDIO	Low Voltage Supply LP-HCSL Outputs	0.9975	1.05-1.8	1.9	V	
Ambient Operating Temperature	T _{COM}	Commercial range	0	25	70	°C	1
	T _{IND}	Industrial range	-40	25	85	°C	1
Input High Voltage	V _{IH}	Single-ended inputs, except SMBus	0.75 V _{DD}		V _{DD} + 0.3	V	
Input Mid Voltage	V _{IM}	Single-ended tri-level inputs ('_tri' suffix)	0.4 V _{DD}		0.6 V _{DD}	V	
Input Low Voltage	V _{IL}	Single-ended inputs, except SMBus	-0.3		0.25 V _{DD}	V	
Input Current	I _{IN}	Single-ended inputs, V _{IN} = GND, V _{IN} = VDD	-5		5	µA	
	I _{INP}	Single-ended inputs V _{IN} = 0 V; Inputs with internal pull-up resistors V _{IN} = VDD; Inputs with internal pull-down resistors	-200		200	µA	
Input Frequency	F _{in}		1		200	MHz	2
Pin Inductance	L _{pin}				7	nH	1
Capacitance	C _{IN}	Logic Inputs, except DIF_IN	1.5		5	pF	1
	C _{INDIF_IN}	DIF_IN differential clock inputs	1.5		2.7	pF	1,6
	C _{OUT}	Output pin capacitance			6	pF	1
Clk Stabilization	T _{STAB}	From V _{DD} power-up and after input clock stabilization or de-assertion of PD# to 1st clock			1	ms	1,2
Input SS Modulation Frequency PCIe	f _{MODINPCIe}	Allowable frequency for PCIe applications (Triangular modulation)	30		33	kHz	
Input SS Modulation Frequency non-Pcie	f _{MODIN}	Allowable frequency for non-Pcie applications (Triangular modulation)	0		66	kHz	
OE# Latency	t _{LATOE#}	DIF start after OE# assertion DIF stop after OE# deassertion	1		3	clocks	1,3
Tdrive_PD#	t _{DRVPD}	DIF output enable after PD# de-assertion			300	µs	1,3
Tfall	t _F	Fall time of single-ended control inputs			5	ns	2
Trise	t _R	Rise time of single-ended control inputs			5	ns	2
SMBus Input Low Voltage	V _{ILSMB}	V _{DDSMB} = 3.3V, see note 4 for V _{DDSMB} < 3.3V			0.8	V	4
SMBus Input High Voltage	V _{IHSMB}	V _{DDSMB} = 3.3V, see note 5 for V _{DDSMB} < 3.3V	2.1		3.3	V	5
SMBus Output Low Voltage	V _{OLSMB}	at I _{PULLUP}			0.4	V	
SMBus Sink Current	I _{PULLUP}	at V _{OL}	4			mA	
Nominal Bus Voltage	V _{DDSMB}	Bus voltage	1.7		3.6	V	
SCLK/SDATA Rise Time	t _{RSMB}	(Max VIL - 0.15V) to (Min VIH + 0.15V)			1000	ns	1
SCLK/SDATA Fall Time	t _{FSMB}	(Min VIH + 0.15V) to (Max VIL - 0.15V)			300	ns	1
SMBus Operating Frequency	f _{MAXSMB}	Maximum SMBus operating frequency			400	kHz	7

¹ Guaranteed by design and characterization, not 100% tested in production.

² Control input must be monotonic from 20% to 80% of input swing.

³ Time from deassertion until outputs are > 200 mV.

⁴ For V_{DDSMB} < 3.3V, V_{ILSMB} < = 0.35V_{DDSMB}.

⁵ For V_{DDSMB} < 3.3V, V_{IHSMB} > = 0.65V_{DDSMB}.

⁶ DIF_IN input.

⁷ The differential input clock must be running for the SMBus to be active.

Electrical Characteristics–DIF Low-Power HCSL Outputs

TA = T_{COM} or T_{IND}; Supply voltages per normal operation conditions; see Test Loads for loading conditions

Parameter	SYMBOL	CONDITIONS	MIN	TYP	MAX	UNITS	NOTES
Slew Rate	Trf	Scope averaging on, fast slew rate setting	1.6	2.6	4.3	V/ns	1,2,3
		Scope averaging on, slow slew rate setting	1.2	2.0	3.2	V/ns	1,2,3
Slew Rate Matching	ΔTrf	Slew rate matching, scope averaging on		6	20	%	1,2,4
Voltage High	V _{HIGH}	Statistical measurement on single-ended signal using oscilloscope math function. (Scope averaging on)	660	758	850	mV	7
Voltage Low	V _{LOW}		-150	43	150		7
Max Voltage	V _{max}	Measurement on single ended signal using absolute value. (Scope averaging off)		775	1150	mV	7
Min Voltage	V _{min}		-300	12			7
Vswing	Vswing	Scope averaging off	300	1428		mV	1,2
Crossing Voltage (abs)	V _{cross_abs}	Scope averaging off	250	391	550	mV	1,5
Crossing Voltage (var)	Δ-V _{cross}	Scope averaging off		14	140	mV	1,6

¹Guaranteed by design and characterization, not 100% tested in production. C_L = 2pF with R_S = 33Ω for Z_o = 50Ω (100Ω differential trace)

² Measured from differential waveform.

³ Slew rate is measured through the Vswing voltage range centered around differential 0V. This results in a +/-150mV window around differential 0V.

⁴ Matching applies to rising edge rate for Clock and falling edge rate for Clock#. It is measured using a +/-75mV window centered on the average cross point where Clock rising meets Clock# falling. The median cross point is used to calculate the voltage thresholds the oscilloscope is to use for the edge rate calculations.

⁵ V_{cross} is defined as voltage where Clock = Clock# measured on a component test board and only applies to the differential rising edge (i.e. Clock rising and Clock# falling).

⁶ The total variation of all V_{cross} measurements in any particular system. Note that this is a subset of V_{cross_min/max} (V_{cross} absolute) allowed. The intent is to limit V_{cross} induced modulation by setting Δ-V_{cross} to be smaller than V_{cross} absolute.

⁷ 660mV V_{high} is the minimum when VDDIO is >= 1.05V +/-5%. If VDDIO is < 1.05V +/-5%, the minimum V_{high} will be VDDIO_{min} - 250mV. For example, for VDDIO = 0.9V +/-5%, V_{HIGHmin} will be 860mV - 250mV = 610mV.

Electrical Characteristics–Current Consumption

TA = T_{COM} or T_{IND}; Supply voltages per normal operation conditions; see Test Loads for loading conditions

PARAMETER	SYMBOL	CONDITIONS	MIN	TYP	MAX	UNITS	NOTES
Operating Supply Current	I _{DDR}	VDDR at 100MHz		3	5	mA	1
	I _{DDDIG}	VDDIG, all outputs at 100MHz		6	10	mA	1
	I _{DDO}	VDDO1.8 + VDDIO, all outputs at 100MHz		35	40	mA	1
Powerdown Current	I _{DDRPD}	VDDR, CKPWRGD_PD# = 0		0.4	1	mA	1,2
	I _{DDDIGPD}	VDDDIG, CKPWRGD_PD# = 0		0.6	1	mA	1, 2
	I _{DDOPD}	VDDO1.8 + VDDIO, CKPWRGD_PD# = 0		0.002	0.1	mA	1, 2

¹ Guaranteed by design and characterization, not 100% tested in production.

² Input clock stopped.

Electrical Characteristics–Output Duty Cycle, Jitter, Skew and PLL Characteristics

TA = T_{COM} or T_{IND}; Supply voltages per normal operation conditions; see Test Loads for loading conditions

PARAMETER	SYMBOL	CONDITIONS	MIN	TYP	MAX	UNITS	NOTES
Duty Cycle Distortion	t _{DCD}	Measured differentially at 100MHz	-1	-0.1	1	%	1,3
Skew, Input to Output	t _{pdBYP}	V _T = 50%	1800	2342	3000	ps	1
Skew, Output to Output	t _{sk3}	V _T = 50%		37	60	ps	1,4
Jitter, Cycle to Cycle	t _{jcc-cyc}	Additive Jitter		0.1	5	ps	1,2

¹ Guaranteed by design and characterization, not 100% tested in production.

² Measured from differential waveform.

³ Duty cycle distortion is the difference in duty cycle between the output and the input clock.

⁴ All outputs at default slew rate.

Electrical Characteristics–Phase Jitter Parameters

TA = T_{COM} or T_{IND}; Supply voltages per normal operation conditions; see Test Loads for loading conditions

PARAMETER	SYMBOL	CONDITIONS	MIN	TYP	MAX	INDUSTRY LIMIT	UNITS	Notes
Additive Phase Jitter	t _{jphPCleG1}	PCIe Gen 1		0.1	5	N/A	ps (p-p)	1,2,3
	t _{jphPCleG2}	PCIe Gen 2 Lo Band 10kHz < f < 1.5MHz		0.1	0.4	N/A	ps (rms)	1,2,5
		PCIe Gen 2 High Band 1.5MHz < f < Nyquist (50MHz)		0.01	0.4	N/A	ps (rms)	1,2,5
	t _{jphPCleG3}	PCIe Gen 3 (2-4MHz or 2-5MHz, CDR = 10MHz)		0.00	0.1	N/A	ps (rms)	1,2,4,5
	t _{jphSGMIIM0}	125MHz, 1.5MHz to 10MHz, -20dB/decade rollover < 1.5MHz, -40db/decade rolloff > 10MHz		165	200	N/A	fs (rms)	1,6
	t _{jphSGMIIM1}	125MHz, 12kHz to 20MHz, -20dB/decade rollover < 1.5MHz, -40db/decade rolloff > 10MHz		251	300	N/A	fs (rms)	1,6

¹ Guaranteed by design and characterization, not 100% tested in production.

² See <http://www.pcisig.com> for complete specs.

³ Sample size of at least 100K cycles. This figure extrapolates to 108ps pk-pk at 1M cycles for a BER of 1-12.

⁴ For RMS figures, additive jitter is calculated by solving the following equation: Additive jitter = SQRT[(total jitter)² - (input jitter)²].

⁵ Driven by 9FGV0831 or equivalent.

⁶ Driven by Rohde & Schwarz SMA100.

Additive Phase Jitter Plot: 125M (12kHz to 20MHz)

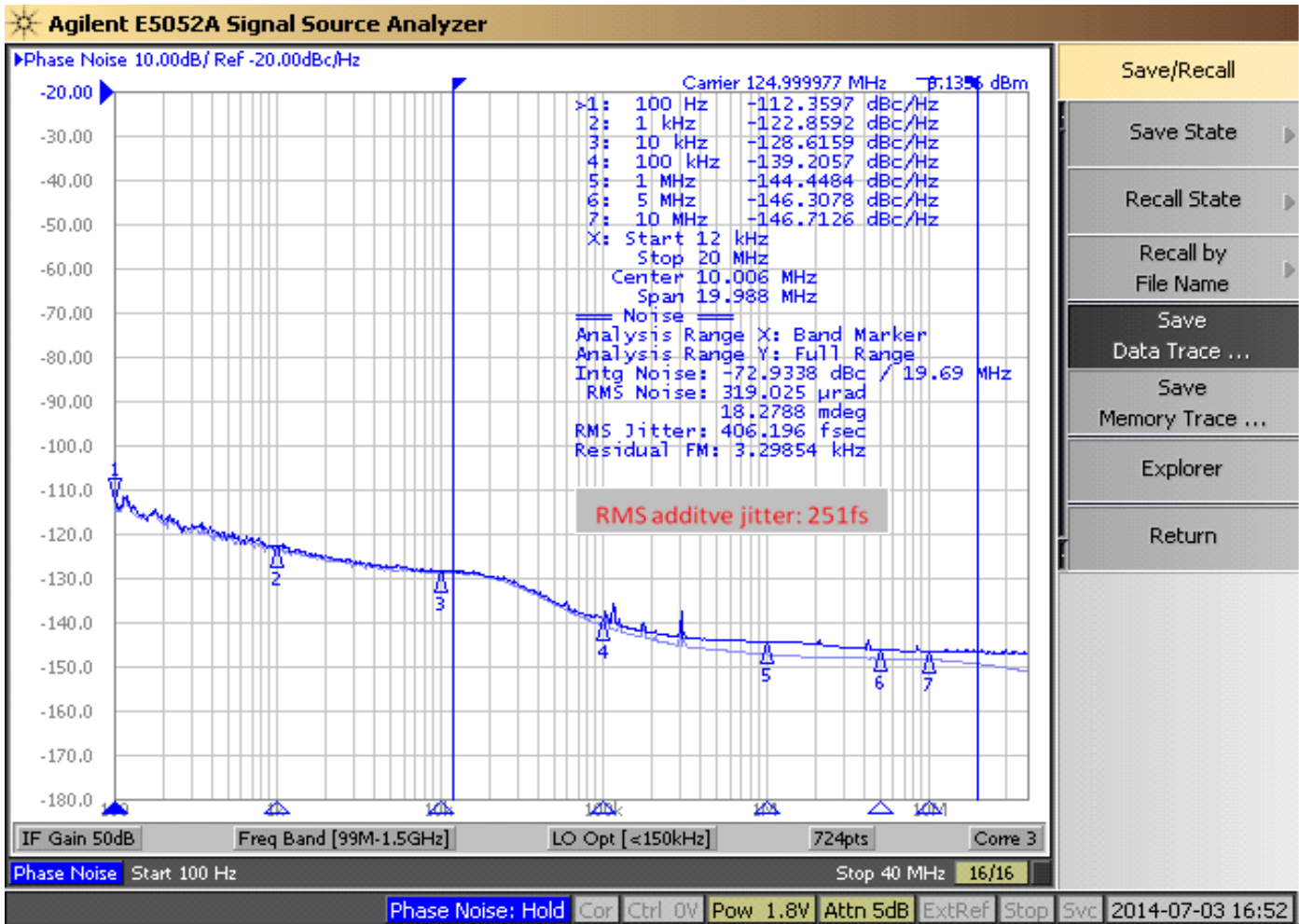

General SMBus Serial Interface Information

How to Write

- Controller (host) sends a start bit
- Controller (host) sends the write address
- IDT clock will **acknowledge**
- Controller (host) sends the beginning byte location = N
- IDT clock will **acknowledge**
- Controller (host) sends the byte count = X
- IDT clock will **acknowledge**
- Controller (host) starts sending Byte N through Byte N+X-1
- IDT clock will **acknowledge** each byte **one at a time**
- Controller (host) sends a stop bit

Index Block Write Operation			
Controller (Host)			IDT (Slave/Receiver)
T	starT bit		
Slave Address			
WR	WRite		
			ACK
Beginning Byte = N			
			ACK
Data Byte Count = X			
			ACK
Beginning Byte N		X Byte	
O			ACK
O			O
O			O
			O
Byte N + X - 1			
			ACK
P	stoP bit		

Note: SMBus Address is Latched on SADR pin.

How to Read

- Controller (host) will send a start bit
- Controller (host) sends the write address
- IDT clock will **acknowledge**
- Controller (host) sends the beginning byte location = N
- IDT clock will **acknowledge**
- Controller (host) will send a separate start bit
- Controller (host) sends the read address
- IDT clock will **acknowledge**
- IDT clock will send the data byte count = X
- IDT clock sends Byte N+X-1
- IDT clock sends **Byte 0 through Byte X (if X_(H) was written to Byte 8)**
- Controller (host) will need to acknowledge each byte
- Controller (host) will send a not acknowledge bit
- Controller (host) will send a stop bit

Index Block Read Operation			
Controller (Host)			IDT (Slave/Receiver)
T	starT bit		
Slave Address			
WR	WRite		
			ACK
Beginning Byte = N			
			ACK
RT	Repeat starT		
Slave Address			
RD	ReaD		
			ACK
			Data Byte Count=X
ACK		X Byte	
ACK			Beginning Byte N
			O
O			O
O			O
			Byte N + X - 1
N	Not acknowledge		
P	stoP bit		

SMBus Table: Output Enable Register ¹

Byte 0	Name	Control Function	Type	0	1	Default
Bit 7	DIF OE7	Output Enable	RW	Low/Low	OE# pin control	1
Bit 6	DIF OE6	Output Enable	RW	Low/Low	OE# pin control	1
Bit 5	DIF OE5	Output Enable	RW	Low/Low	OE# pin control	1
Bit 4	DIF OE4	Output Enable	RW	Low/Low	OE# pin control	1
Bit 3	DIF OE3	Output Enable	RW	Low/Low	OE# pin control	1
Bit 2	DIF OE2	Output Enable	RW	Low/Low	OE# pin control	1
Bit 1	DIF OE1	Output Enable	RW	Low/Low	OE# pin control	1
Bit 0	DIF OE0	Output Enable	RW	Low/Low	OE# pin control	1

1. A low on these bits will override the OE# pin and force the differential output Low/Low

SMBus Table: Output Enable and Output Amplitude Control Register

Byte 1	Name	Control Function	Type	0	1	Default
Bit 7	Reserved					0
Bit 6	Reserved					1
Bit 5	DIF OE8	Output Enable	RW	Low/Low	OE# pin control	1
Bit 4	Reserved					0
Bit 3	Reserved					1
Bit 2	Reserved					1
Bit 1	AMPLITUDE 1	Controls Output Amplitude	RW	00 = 0.6V	01 = 0.7V	1
Bit 0	AMPLITUDE 0		RW	10 = 0.8V	11 = 0.9V	0

1. A low on the DIF OE bit will override the OE# pin and force the differential output Low/Low

SMBus Table: DIF Slew Rate Control Register

Byte 2	Name	Control Function	Type	0	1	Default
Bit 7	SLEWRATESEL DIF7	Adjust Slew Rate of DIF7	RW	Slow setting	Fast setting	1
Bit 6	SLEWRATESEL DIF6	Adjust Slew Rate of DIF6	RW	Slow setting	Fast setting	1
Bit 5	SLEWRATESEL DIF5	Adjust Slew Rate of DIF5	RW	Slow setting	Fast setting	1
Bit 4	SLEWRATESEL DIF4	Adjust Slew Rate of DIF4	RW	Slow setting	Fast setting	1
Bit 3	SLEWRATESEL DIF3	Adjust Slew Rate of DIF3	RW	Slow setting	Fast setting	1
Bit 2	SLEWRATESEL DIF2	Adjust Slew Rate of DIF2	RW	Slow setting	Fast setting	1
Bit 1	SLEWRATESEL DIF1	Adjust Slew Rate of DIF1	RW	Slow setting	Fast setting	1
Bit 0	SLEWRATESEL DIF0	Adjust Slew Rate of DIF0	RW	Slow setting	Fast setting	1

SMBus Table: DIF Slew Rate Control Register

Byte 3	Name	Control Function	Type	0	1	Default
Bit 7	Reserved					1
Bit 6	Reserved					1
Bit 5	Reserved					0
Bit 4	Reserved					0
Bit 3	Reserved					0
Bit 2	Reserved					1
Bit 1	Reserved					1
Bit 0	SLEWRATESEL DIF8	Adjust Slew Rate of DIF8	RW	Slow setting	Fast setting	1

Byte 4 is Reserved and reads back 'hFF'

SMBus Table: Revision and Vendor ID Register

Byte 5	Name	Control Function	Type	0	1	Default
Bit 7	RID3	Revision ID	R	A rev = 0000		0
Bit 6	RID2		R			0
Bit 5	RID1		R			0
Bit 4	RID0		R			0
Bit 3	VID3	VENDOR ID	R	0001 = IDT		0
Bit 2	VID2		R			0
Bit 1	VID1		R			0
Bit 0	VID0		R			1

SMBus Table: Device Type/Device ID

Byte 6	Name	Control Function	Type	0	1	Default
Bit 7	Device Type1	Device Type	R	00 = FG, 01 = DB 10 = DM, 11= DB fanout only		1
Bit 6	Device Type0		R			1
Bit 5	Device ID5	Device ID	R	001001binary or 09 hex		0
Bit 4	Device ID4		R			0
Bit 3	Device ID3		R			1
Bit 2	Device ID2		R			0
Bit 1	Device ID1		R			0
Bit 0	Device ID0		R			1

SMBus Table: Byte Count Register

Byte 7	Name	Control Function	Type	0	1	Default
Bit 7				Reserved		0
Bit 6				Reserved		0
Bit 5				Reserved		0
Bit 4	BC4	Byte Count Programming	RW	Writing to this register will configure how many bytes will be read back, default is = 8 bytes.		0
Bit 3	BC3		RW			1
Bit 2	BC2		RW			0
Bit 1	BC1		RW			0
Bit 0	BC0		RW			0

Marking Diagrams

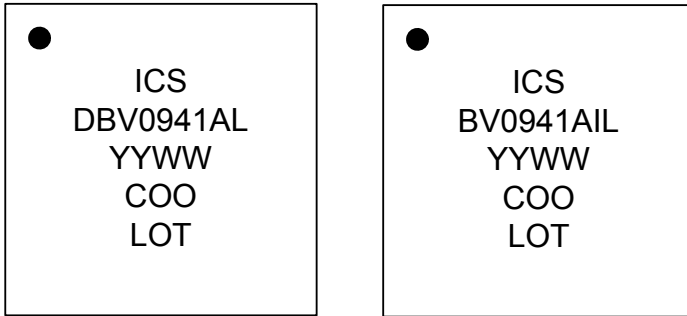

Notes:

1. "LOT" is the lot sequence number.
2. "COO" denotes country of origin.
3. YYWW is the last two digits of the year and week that the part was assembled.
4. Line 2: truncated part number
5. "L" denotes RoHS compliant package.
6. "I" denotes industrial temperature range device.

Thermal Characteristics

PARAMETER	SYMBOL	CONDITIONS	PKG	TYP VALUE	UNITS	NOTES
Thermal Resistance	θ_{JC}	Junction to Case	NDG48	33	°C/W	1
	θ_{Jb}	Junction to Base		2.1	°C/W	1
	θ_{JA0}	Junction to Air, still air		37	°C/W	1
	θ_{JA1}	Junction to Air, 1 m/s air flow		30	°C/W	1
	θ_{JA3}	Junction to Air, 3 m/s air flow		27	°C/W	1
	θ_{JA5}	Junction to Air, 5 m/s air flow		26	°C/W	1

¹ePad soldered to board

Package Outline and Dimensions (NDG48)

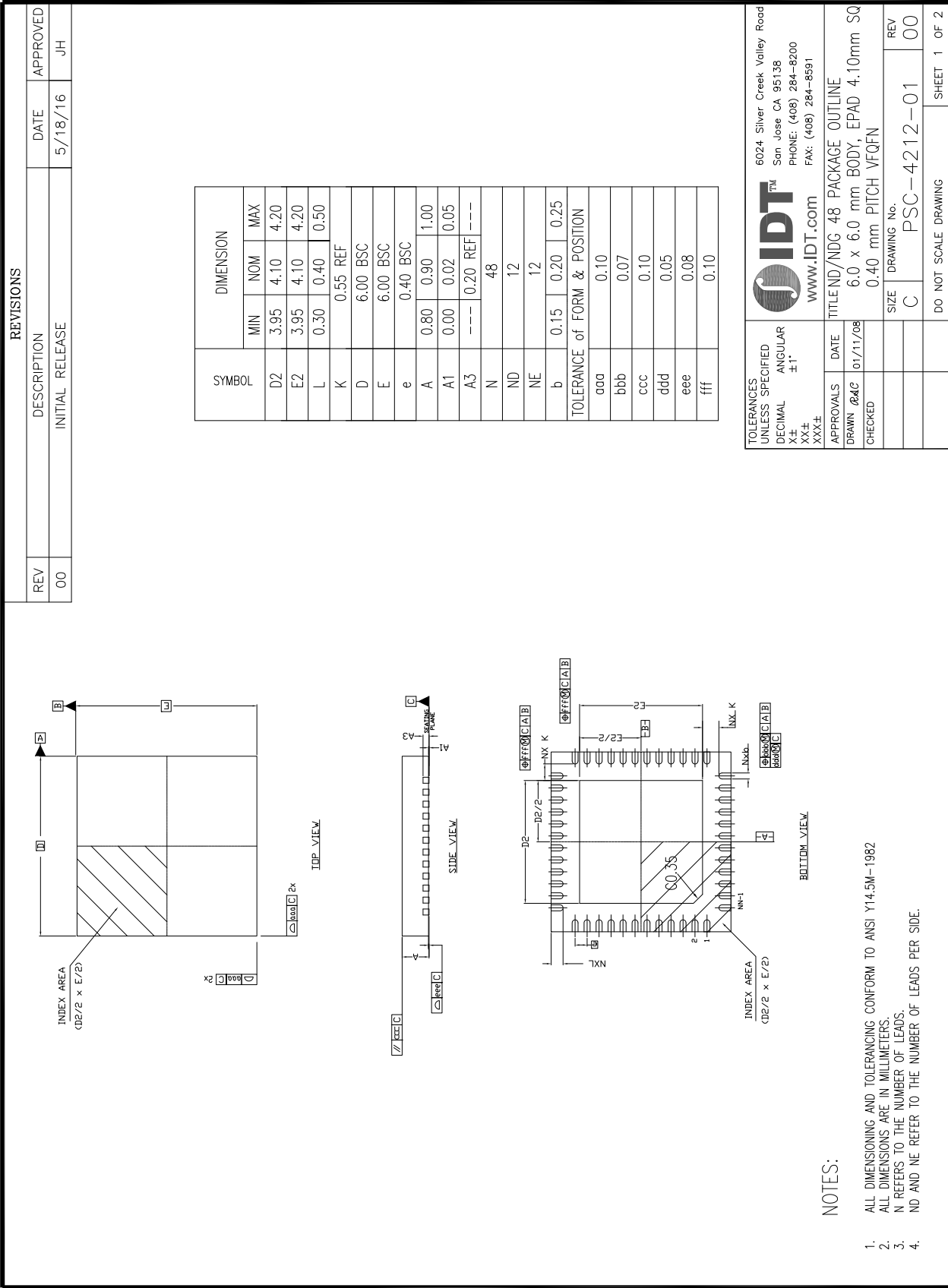

Package Outline and Dimensions (NDG48), cont.

REVISIONS			
REV	DESCRIPTION	DATE	APPROVED
00	INITIAL RELEASE	5/18/16	JH

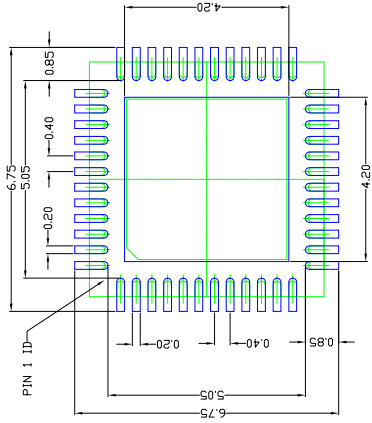

RECOMMENDED LAND PATTERN DIMENSION

- NOTES:
1. ALL DIMENSIONS ARE IN mm. ANGLES IN DEGREES.
 2. TOP DOWN VIEW, AS VIEWED ON PCB.
 3. COMPONENT OUTLINE SHOWS FOR REFERENCE IN GREEN.
 4. LAND PATTERN IN BLUE. NSMD PATTERN ASSUMED.
 5. LAND PATTERN RECOMMENDATION PER IPC-7351B, GENERIC REQUIREMENT FOR SURFACE MOUNT DESIGN AND LAND PATTERN.

		6024 Silver Creek Valley Road San Jose CA 95138 PHONE: (408) 284-8200 FAX: (408) 284-8591 WWW.IDT.COM	
TOLERANCES UNLESS SPECIFIED	DECIMAL	ANGULAR	±1°
APPROVALS	DATE	TITLE ND/NDG 48 PACKAGE OUTLINE	
DRAWN 024C	01/11/08	6.0 x 6.0 mm BODY, EPAD 4.10mm SQ	
CHECKED		0.40 mm PITCH VFQFN	
		SIZE	DRAWING No.
		C	PSC-4212-01
		REV	00
		DO NOT SCALE DRAWING	
		SHEET 2 OF 2	

Ordering Information

Part / Order Number	Shipping Packaging	Package	Temperature
9DBV0941AKLF	Trays	48-pin VFQFPN	0 to +70° C
9DBV0941AKLFT	Tape and Reel	48-pin VFQFPN	0 to +70° C
9DBV0941AKILF	Trays	48-pin VFQFPN	-40 to +85° C
9DBV0941AKILFT	Tape and Reel	48-pin VFQFPN	-40 to +85° C

“LF” suffix to the part number are the Pb-Free configuration and are RoHS compliant.

“A” is the device revision designator (will not correlate with the datasheet revision).

Revision History

Rev.	Initiator	Issue Date	Description	Page #
A	RDW	8/27/2014	<ol style="list-style-type: none"> Updated front page text. Updated block diagram. Updated electrical tables. Updated test loads diagrams. Updated Smbus byte 2, 3 and 6 labeling. Functionality did not change. Updated min Vhigh on DIF outputs from 630mV to 660mV, correcting a typo. Corrected Conditions for Slew Rate in DIF Low-Power HCSL Outputs. Added additive phase jitter image. Move to final. 	Various
B	RDW	8/28/2014	<ol style="list-style-type: none"> Corrected Supply Voltage in Absolute Maximum Ratings. Lowered additive phase jitter specs. 	Various
C	RDW	3/28/2016	<ol style="list-style-type: none"> Revised front page text extensively. Added note about Spread Spectrum Compatibility to the features. Change pin name of VDDA1.8 to VDD1.8 and GNDA to GND to clarify that this part does not have a PLL. This is a document change only. There is no silicon change. Corrected OE8# to indicate an internal pull down, not a pull up. Added epad nomenclature to DS Updated package drawing to latest version - no package change. Added reference to AN-891. Updated "Current Consumption" table to remove references to VDDA1.8 Added "RMS additive phase jitter: 251fs" to phase noise plot Updated "Clock Input Parameters" table for consistency - no silicon change. Updated "Output Duty Cycle, Jitter, Skew and PLL Characteristics" and "Phase Jitter" tables to remove references to bypass mode. 	1-5,7-9 14
D	RDW	3/14/2017	<ol style="list-style-type: none"> Removed "...bypass mode." reference in note 3 under Output Duty Cycle table. Corrected spelling errors/typos. Change VDDA to VDDO1.8 in Current Consumption table. Update Additive Phase Jitter conditions for PCIe Gen3. Updated package outline drawings. 	8,9,15,16



Corporate Headquarters
6024 Silver Creek Valley Road
San Jose, CA 95138 USA
www.IDT.com

Sales
1-800-345-7015 or 408-284-8200
Fax: 408-284-2775
www.IDT.com/go/sales

Tech Support
www.idt.com/go/support

DISCLAIMER Integrated Device Technology, Inc. (IDT) and its affiliated companies (herein referred to as "IDT") reserve the right to modify the products and/or specifications described herein at any time, without notice, at IDT's sole discretion. Performance specifications and operating parameters of the described products are determined in an independent state and are not guaranteed to perform the same way when installed in customer products. The information contained herein is provided without representation or warranty of any kind, whether express or implied, including, but not limited to, the suitability of IDT's products for any particular purpose, an implied warranty of merchantability, or non-infringement of the intellectual property rights of others. This document is presented only as a guide and does not convey any license under intellectual property rights of IDT or any third parties.

IDT's products are not intended for use in applications involving extreme environmental conditions or in life support systems or similar devices where the failure or malfunction of an IDT product can be reasonably expected to significantly affect the health or safety of users. Anyone using an IDT product in such a manner does so at their own risk, absent an express, written agreement by IDT.

Integrated Device Technology, IDT and the IDT logo are trademarks or registered trademarks of IDT and its subsidiaries in the United States and other countries. Other trademarks used herein are the property of IDT or their respective third party owners. For datasheet type definitions and a glossary of common terms, visit www.idt.com/go/glossary. Integrated Device Technology, Inc.. All rights reserved.

Компания «Life Electronics» занимается поставками электронных компонентов импортного и отечественного производства от производителей и со складов крупных дистрибьюторов Европы, Америки и Азии.

С конца 2013 года компания активно расширяет линейку поставок компонентов по направлению коаксиальный кабель, кварцевые генераторы и конденсаторы (керамические, пленочные, электролитические), за счёт заключения дистрибьюторских договоров

Мы предлагаем:

- Конкуренспособные цены и скидки постоянным клиентам.
- Специальные условия для постоянных клиентов.
- Подбор аналогов.
- Поставку компонентов в любых объемах, удовлетворяющих вашим потребностям.
- Приемлемые сроки поставки, возможна ускоренная поставка.
- Доставку товара в любую точку России и стран СНГ.
- Комплексную поставку.
- Работу по проектам и поставку образцов.
- Формирование склада под заказчика.
- Сертификаты соответствия на поставляемую продукцию (по желанию клиента).
- Тестирование поставляемой продукции.
- Поставку компонентов, требующих военную и космическую приемку.
- Входной контроль качества.
- Наличие сертификата ISO.

В составе нашей компании организован Конструкторский отдел, призванный помогать разработчикам, и инженерам.

Конструкторский отдел помогает осуществить:

- Регистрацию проекта у производителя компонентов.
- Техническую поддержку проекта.
- Защиту от снятия компонента с производства.
- Оценку стоимости проекта по компонентам.
- Изготовление тестовой платы монтаж и пусконаладочные работы.



Тел: +7 (812) 336 43 04 (многоканальный)
Email: org@lifeelectronics.ru