

# ▶ MXE-1000 Series

Intel® Atom™ Fanless Embedded Computer with Integrated I/O



## Introduction

ADLINK's MXE-1000 series is an exceptionally rugged embedded computer for operating in harsh environments. Its -20 to 70°C\* temperature range allows it to operate outdoors in both hot summer days and cold winter nights. The Matrix can also be deployed in factory planes or on vehicles as it can withstand 5 Grms vibration. And, its fanless and cable-less structure ensures extensive durability for long-term usage.

The MXE-1000 series features the Intel® Atom™ N270 1.6 GHz processor to deliver adequate performance at low-power. The MXE-1000 also integrates versatile generic and special-purpose I/O features to support a wide variety of applications. The on-board Gigabit Ethernet and 1394b ports are designed for connecting cameras for surveillance and image recognition applications, while its COM ports fit requirements in most machine automation and facility management applications.

Combining rugged design and integrated I/O functions, the ADLINK MXE-1000 series offers the most versatile choice for your applications.

## Features

- Intel® Atom™ N270 1.6 GHz processor + 945GSE chipset
- Rugged, -20°C to 70°C fanless operation\*
- Built-in 6 Vdc to 36 Vdc wide-range DC power input
- Up to three 1000/100/10 Mbps Ethernet ports
- Two 1394b FireWire ports (MXE-1020 only)
- Two RS-232 ports and two RS-232/422/485 ports
- One internal PCIe Mini Card socket with an USIM socket
- One external CF socket

## Applications

- Intelligent Transportation
- Facility Management
- Environment Monitoring
- Machine Automation
- Video Surveillance/Recognition
- Building Automation

## Software Support

- Windows® CE6.0 / XP / XP Embedded / 7, Linux\*
- \*Linux Distribution by Request



Inside MXE-1000 Series

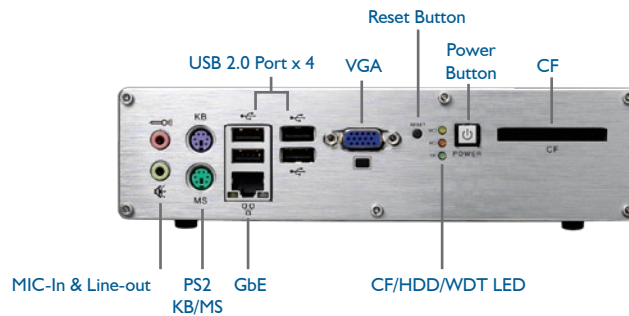

MXE-1000 Series Front Panel

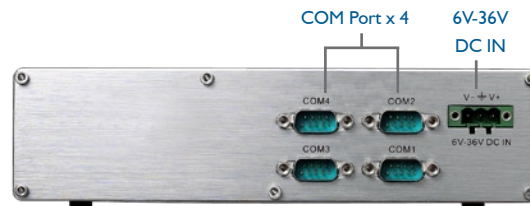

MXE-1005 Back Panel

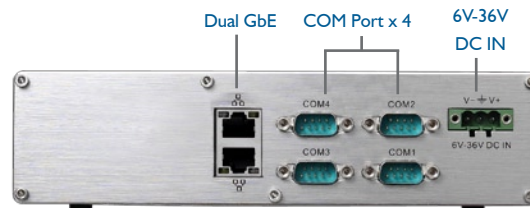

MXE-1010 Back Panel

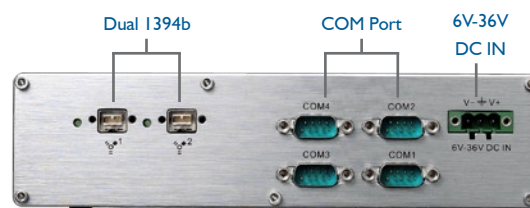

MXE-1020 Back Panel

\*Extending the operating temperature to -20°C to +70°C is optional and requires use of an industrial solid-state drive storage device.

## Specifications

Model Name	MXE-1005	MXE-1010	MXE-1020
<b>System Core</b>			
■ Processor	Intel® Atom™ N270 1.6 GHz CPU		
■ Chipset	Intel® 945GSE Graphic Memory Control Hub Intel® I/O Controller Hub 7 Mobile (ICH7-M)		
■ Video	Analog CRT, supports QXGA (2048 x 1536) resolution		
■ Memory	1 GB DDR2 533 MHz SODIMM module		
<b>I/O Interface</b>			
■ Ethernet	1 GbE port (Realtek® 8111C)	3 GbE ports (Realtek® 8111C+Intel® 82574) (support teaming function)	1 GbE port (Realtek® 8111C)
■ I394b	-	-	2 I394b FireWire 800 ports
■ Serial Port	2 RS-232/422/485 (jumper selectable, COM1 & COM2) 2 RS-232 (COM3 & COM4)		
■ USB	4 USB 2.0 ports		
■ Mini-PCIe	1 internal PCIe mini card socket		
■ USIM	1 USIM socket for 3G communication (used with 3G Mini-PCIe module)		
■ Audio	1 mic-in and 1 line-out		
■ KB/MS	1 PS/2 keyboard and 1 PS/2 mouse		
<b>Power Supply</b>			
■ DC Input	Built-in 6-36 Vdc wide-range DC input 3P pluggable connector with latch (V-, GND, V+)		
■ AC Input	Optional 40 W external AC-DC adapter for AC input		
<b>Storage Device</b>			
■ SATA HDD	On-board SATA port for 2.5" HDD/SSD installation		
■ CompactFlash	1 type I CF socket, supporting PIO and DMA modes		
<b>Mechanical</b>			
■ Dimensions	210 mm (W) x 170 mm (D) x 53 mm (H) (8.3" x 6.7" x 2.1")		
■ Weight	1.8 kg (3.97 lbs)		
■ Mounting	VESA 100 wall mounting kit		
<b>Environmental</b>			
■ Operating Temperature*	Standard: 0°C to 50°C (w/HDD) Extended option: -20°C to 70°C (w/industrial SSD)		
■ Storage Temperature	-40°C to 85°C (excluding HDD/SSD/CF)		
■ Humidity	~95% @ 40°C (non-condensing)		
■ Vibration	Operating, 5 Grms, 5-500 Hz, 3 axes (w/ CF or SSD) Operating, 0.7 Grms, 5-500 Hz, 3 axes (w/ HDD)		
■ Shock	Operating, 100 G, half-sine 11 ms duration (w/ CF or SSD)		
■ EMC	CE and FCC Class A		

\*Extending the operating temperature to -20°C to +70°C is optional and requires use of an industrial solid-state drive storage device.

## Ordering Information

Model Name	CPU	GbE	I394b	COM	USB	Memory
MXE-1005	Intel® Atom™ N270 fanless embedded computer	1	-	4	4	1 GB DDR2
MXE-1010	Intel® Atom™ N270 fanless embedded computer	3	-	4	4	1 GB DDR2
MXE-1020	Intel® Atom™ N270 fanless embedded computer	1	2	4	4	1 GB DDR2

## Optional Accessories

2 GB DDR2 Upgrade	Upgrade to 2 GB DDR2 memory
160 GB HDD Option	Factory-installed 160 GB SATA hard disk drive (0 to 60°C)
32 GB SSD Option	Factory-installed 32 GB SATA solid-state drive (0 to 70°C)
8 GB Industrial SSD Option	Factory-installed 8 GB industrial-grade SATA solid-state drive (-40 to 85°C)
40 W AC-DC Adapter	40 W industrial-grade AC-DC adapter (-20 to 70°C)
Extended Temperature Option*	Optional Screening to extend the operating temperature of the MXE-1000 series to -20°C to 70°C

\*This option guarantees cold boot of the system at -20°C and operation with 100% loading at 70°C. The industrial solid-state drive storage option is required.  
Updated 03-28, 2012. ©2012 ADLINK Technology, Inc. All Rights Reserved. All specifications are subject to change without further notice.

Компания «Life Electronics» занимается поставками электронных компонентов импортного и отечественного производства от производителей и со складов крупных дистрибьюторов Европы, Америки и Азии.

С конца 2013 года компания активно расширяет линейку поставок компонентов по направлению коаксиальный кабель, кварцевые генераторы и конденсаторы (керамические, пленочные, электролитические), за счёт заключения дистрибьюторских договоров

Мы предлагаем:

- Конкурентоспособные цены и скидки постоянным клиентам.
- Специальные условия для постоянных клиентов.
- Подбор аналогов.
- Поставку компонентов в любых объемах, удовлетворяющих вашим потребностям.
- Приемлемые сроки поставки, возможна ускоренная поставка.
- Доставку товара в любую точку России и стран СНГ.
- Комплексную поставку.
- Работу по проектам и поставку образцов.
- Формирование склада под заказчика.
- Сертификаты соответствия на поставляемую продукцию (по желанию клиента).
- Тестирование поставляемой продукции.
- Поставку компонентов, требующих военную и космическую приемку.
- Входной контроль качества.
- Наличие сертификата ISO.

В составе нашей компании организован Конструкторский отдел, призванный помогать разработчикам, и инженерам.

Конструкторский отдел помогает осуществить:

- Регистрацию проекта у производителя компонентов.
- Техническую поддержку проекта.
- Защиту от снятия компонента с производства.
- Оценку стоимости проекта по компонентам.
- Изготовление тестовой платы монтаж и пусконаладочные работы.



Тел: +7 (812) 336 43 04 (многоканальный)

Email: [org@lifeelectronics.ru](mailto:org@lifeelectronics.ru)