

# MACX MCR-EX-SL-RPSSI-I-UP(-SP)



**Supply and input signal conditioner, Ex-i,  
with wide range supply**

Data sheet  
103561\_en\_00

© PHOENIX CONTACT 2014-08-19

## 1 Description

The **MACX MCR-EX-SL-RPSSI-I-UP(-SP)** repeater power supply and input signal conditioner is designed for the operation of intrinsically safe measuring transducers and mA current sources installed in hazardous areas.

2-wire measuring transducers are supplied with energy and analog 0/4... 20 mA measured values from the hazardous area are transferred to the non-hazardous area. The module output can be operated actively or passively.

The analog measured value can be overlaid with digital (HART) communication signals on the hazardous or non-hazardous side and transmitted bidirectionally. An additional resistance can be switched in the output circuit in order to increase the HART impedance in low-ohmic systems using a switch on the front of the device.

The energy supply has been designed as a wide range supply (UP).

Test sockets are integrated into the connectors for connecting the HART communicators.

Certified for safety-related applications up to SIL 2 according to IEC/EN 61508.

### 1.1 Properties

- Input 0/4 mA ... 20 mA input, intrinsically safe [Ex ia], powered and not powered
- Measuring transducer supply voltage >16 V
- Output 0/4 mA ... 20 mA (active or passive)
- Output 0/1 ... 5 V
- Bidirectional HART transmission
- Error indication according to NAMUR NE 43
- SIL 2 according to IEC/EN 61508
- Reliable electrical isolation between input, output, and supply
- Installation in zone 2 permitted
- Wide-range power supply of 24 V ... 230 V AC/DC
- Plug-in terminals with screw connection (MACX MCR-EX-SL-RPSSI-I-UP) or spring connection (push-in) (MACX MCR-EX-SL-RPSSI-I-UP-SP)
- Housing overall width 17.5 mm



#### **WARNING: Explosion hazard**

**The module is an item of associated electrical equipment for intrinsically safe circuits. It is designed for use in zone 2, if specific conditions are observed.**

When installing and operating the device, the applicable safety directives (including national safety directives), accident prevention regulations, as well as general technical regulations must be observed.



#### **WARNING: Explosion hazard**

**Observe the safety regulations and installation notes on page 6.**



Make sure you always use the latest documentation.  
It can be downloaded at [phoenixcontact.net/products](http://phoenixcontact.net/products).



This data sheet is valid for all products listed on page 3.

## Table of contents

1	Description.....	1
1.1	Properties.....	1
2	Ordering Data .....	3
3	Technical Data.....	3
4	Safety regulations and installation notes.....	6
4.1	Installation notes .....	6
4.2	Intrinsic safety .....	6
4.3	Installation in the hazardous area (zone 2) .....	6
4.4	Areas with a danger of dust explosions .....	6
4.5	Safety-related applications (SIL) .....	6
5	Installation .....	7
5.1	Connection notes .....	7
5.2	Electrostatic discharge .....	7
5.3	Design .....	7
5.4	Basic circuit diagram .....	8
5.5	Input (intrinsically safe).....	8
5.6	Output current (without HART communication) .....	8
5.7	Output current (with HART communication) .....	8
5.8	HART communicators .....	8
5.9	Output, voltage .....	8
5.10	Supply voltage.....	8
5.11	Dimensions .....	9
5.12	Assembly.....	9
5.13	Connection of the cables.....	9
5.14	Startup.....	9
5.15	Level shift .....	10
6	Comparison of safety data .....	11
7	Safety-related applications (SIL 2).....	12
7.1	Safety function and safety demand .....	12
7.2	Safety integrity requirements.....	12
7.3	Condition.....	13
7.4	Installation and Startup.....	13
7.5	Notes on operation .....	13
7.6	Recurring checks .....	13
7.7	Repair.....	14
7.8	Standards (SIL 2) .....	14
7.9	Abbreviations .....	15

## 2 Ordering Data

### Repeater power supply and input signal conditioner Ex

Description	Type	Order No.	Pcs. / Pkt.
Supply and input signal conditioners, Ex-i, wide range supply with screw connection	MACX MCR-EX-SL-RPSSI-I-UP	2865793	1
Supply and input signal conditioners, Ex-i, wide range supply with spring connection	MACX MCR-EX-SL-RPSSI-I-UP-SP	2924029	1

## 3 Technical Data

Input	Operation as repeater power supply	Operation as input signal conditioner
Input	Current input, intrinsically safe	Current input, intrinsically safe
Input signal	$\Delta$ CAT II (250 V against $\downarrow$ ) (terminal assignment 4.1, 4.2) 4 mA ... 20 mA	$\Delta$ CAT II (250 V against $\downarrow$ ) (terminal assignment 5.1, 5.2) 0 mA ... 20 mA, 4 mA ... 20 mA
Supply voltage	> 16 V (at 20 mA) > 15.3 V (at 22.5 mA)	–
Voltage drop	–	< 3.5 V (at 20 mA)
Output	Operation as repeater power supply	Operation as input signal conditioner
Output	Current output/voltage output, short-circuit-proof	Current output/voltage output, short-circuit-proof
Output signal	$\Delta$ CAT II (250 V against $\downarrow$ ) Configurable via DIP switch	$\Delta$ CAT II (250 V against $\downarrow$ ) Configurable via DIP switch
Output signal, active, current	4 mA ... 20 mA	0 mA ... 20 mA 4 mA ... 20 mA
Output signal, passive, current, external source voltage 14 V ... 26 V	4 mA ... 20 mA	0 mA ... 20 mA 4 mA ... 20 mA
Output signal, voltage, internal resistance, 250 $\Omega$ , 0.1%	1 V ... 5 V	0 V ... 5 V 1 V ... 5 V
Transmission behavior	1 : 1	1 : 1
Load	< 600 $\Omega$ (20 mA) / < 525 $\Omega$ (22.5 mA)	< 600 $\Omega$ (20 mA) / < 525 $\Omega$ (22.5 mA)
Output ripple	< 20 mV <sub>eff</sub>	< 20 mV <sub>eff</sub>
Underload/Overload range	0 mA ... 23 mA, acc. to NE 43	0 mA ... 23 mA, acc. to NE 43
Output behavior in the event of an error		
In the event of a wire break in the input	0 mA (acc. to NE 43 I < 3.6 mA)	0 mA (acc. to NE 43 I < 3.6 mA)
In the event of a line short-circuit in the input	$\geq$ 22.5 mA (acc. to NE 43 I > 21 mA)	0 mA (acc. to NE 43 I < 3.6 mA)
General data	Operation as repeater power supply	Operation as input signal conditioner
Supply voltage range	24 V AC/ DC ... 230 V AC/DC (-20% ... +10%, 50 Hz ... 60 Hz)	24 V AC/ DC ... 230 V AC/DC (-20% ... +10%, 50 Hz ... 60 Hz)
Current consumption		
V <sub>B</sub> = 24 V DC; I <sub>sig</sub> = 20 mA	< 80 mA	< 45 mA
V <sub>B</sub> = 230 V AC; I <sub>sig</sub> = 20 mA	< 23 mA	< 15 mA
Power consumption		
V <sub>B</sub> = 24 V DC / 230 V AC; I <sub>sig</sub> = 20 mA	< 1.9 W / 2 W	< 1.1 W / 1.3 W
V <sub>B</sub> = 230 V AC; I <sub>sig</sub> = 20 mA	< 5 VA	< 3.3 VA
Power dissipation		
V <sub>B</sub> = 24 V DC; I <sub>sig</sub> = 20 mA	< 1.6 W	< 1.1 W
V <sub>B</sub> = 230 V AC; I <sub>sig</sub> = 20 mA	< 1.7 W	< 1.3 W
Temperature coefficient	< 0.01%/K	< 0.01%/K
Step response (10% ... 90%), for jump 4 mA ... 20 mA	< 600 $\mu$ s	< 600 $\mu$ s

General data [...]	Operation as repeater power supply	Operation as input signal conditioner
Transmission errors		
Maximum	< 0.1% (of end value)	< 0.1% (of final value)
Typical	< 0.05% (of final value)	< 0.05% (of final value)
Communication	HART protocol	HART protocol
Signal bandwidth	As per HART specifications	As per HART specifications
From hazardous area to non-hazardous area	0 kHz ... 3 kHz	0 kHz ... 3 kHz
From non-hazardous area to hazardous area	200 Hz ... 10 kHz	200 Hz ... 10 kHz
Test sockets, e.g., for HART communication	2-mm sockets in the connector	2-mm sockets in the connector
Status indicator	Green LED (PWR, supply voltage)	
Housing material	Polyamide PA 66-FR	
Color	Green	
Degree of protection	IP20	
Width x height x depth	17.5 mm x 112.5 mm 114.5 x mm (MACX MCR-EX-SL-RPSSI-I-UP) 17.5 mm x 116 mm 114.5 x mm (MACX MCR-EX-SL-RPSSI-I-UP-SP)	
Inflammability class according to UL 94	V0	
Design	Terminal housing for mounting on DIN rails	
<b>Electrical isolation</b>		
Input/output	375 V <sub>peak</sub> (peak value acc. to EN 60079-11)	
Input / Power supply	375 V <sub>peak</sub> (peak value acc. to EN 60079-11)	
Input / Output / Power supply	300 V <sub>eff</sub> rated insulation voltage (Surge voltage category II, pollution degree 2, safe electrical isolation as per EN 61010-1)	
Test voltage	2.5 kV AC (50 Hz, 1 min)	
<b>Ambient conditions</b>		
Ambient temperature		
Operation	-20 °C ... +60 °C (any mounting position)	
Storage/Transport	-40 °C ... +80 °C	
Permissible humidity (operation)	10% ... 95% (non-condensing)	
Maximum altitude	2000 m above sea level	
<b>Connection data</b>		
	<b>MACX MCR-EX-SL-RPSSI-I-UP</b>	<b>MACX MCR-EX-SL-RPSSI-I-UP-SP</b>
Connection method	Screw connection	Push-in spring connection
Conductor cross-section		
solid	0.2 mm <sup>2</sup> ... 2.5 mm <sup>2</sup>	0.2 mm <sup>2</sup> ... 1.5 mm <sup>2</sup>
flexible	0.2 mm <sup>2</sup> ... 2.5 mm <sup>2</sup>	0.2 mm <sup>2</sup> ... 1.5 mm <sup>2</sup>
AWG/kcmil	24 ... 14	24 ... 16
Stripping length	7 mm	8 mm
Tightening torque	0.5 Nm ... 0.6 Nm	-
<b>Conformance</b>		
EMC Directive 2004/108/EC	EN 61000-6-2*, EN 61000-6-4, EN 61326-1	
Ex Directive (ATEX)	EN 60079-0, EN 60079-11, EN 60079-15	

\* When exposed to interference, there may be minimal deviations.

**Safety data according to ATEX for intrinsically safe circuits****Repeater power supply operation**

Voltage, maximum $V_o$	25.2 V
Maximum current $I_o$	93 mA
Maximum power $P_o$	587 mW
Gas group	IIC
Maximum inductance $L_o$	2 mH
Maximum capacity $C_o$	107 nF

**Input signal conditioner operation**

Maximum voltage $V_i$	30 V
Maximum current $I_i$	130 mA
Maximum inductance $L_i$	negligible
Maximum capacity $C_i$	negligible
Maximum voltage $V_m$ for output	253 V AC (125 V DC)
Maximum voltage $V_m$ for power supply	253 V AC/DC

**Approvals**

ATEX	BVS 08 ATEX E 094 X	Ⓢ II (1)G [Ex ia Ga] IIC/IIB; Ⓢ II (1)D [Ex ia Da] IIIC Ⓢ II 3(1)G Ex nA [ia Ga] IIC/IIB T4 Gc
IECEx approval	IECEx BVS 08,0035X	[Ex ia Ga] IIC/IIB [Ex ia Da] IIIC Ex nA [ia Ga] IIC/IIB T4 Gc
UL, USA/Canada		Ⓢ, C.D.-No 83104549; IS for Class I,II,III, Division 1 and Zone 0; Installation in Class I, Division 2 and Zone 2
Functional safety (SIL)		SIL 2 according to IEC/EN 61508

## 4 Safety regulations and installation notes

### 4.1 Installation notes

- The device is an item of associated equipment (category 1) with “intrinsic safety” protection type and can be installed in zone 2 potentially explosive areas as a category 3 device.

It meets the requirements of

EN 60079-0:2012, IEC 60079-0 Ed. 6.0,

EN 60079-11:2012, IEC 60079-11 Ed. 6.0

EN 60079-15:2010, IEC 60079-15 Ed. 4.0

Installation, operation, and maintenance may only be carried out by qualified electricians.

Follow the installation instructions as described.

When installing and operating the device, the applicable regulations and safety directives (including national safety directives), as well as general technical regulations, must be observed.

For the safety data, refer to this document and the certificates (EC examination certificate and other approvals if appropriate).

- Do not open or modify the device. Do not repair the device yourself; replace it with an equivalent device instead. Repairs may only be carried out by the manufacturer.
- The IP20 degree of protection (EN/IEC 60529) of the device is intended for use in a clean and dry environment. Do not subject the device to mechanical or thermal loads that exceed the specified limits.
- The device complies with the EMC regulations for industrial areas (EMC class A). When using the device in residential areas, it may cause radio interference.

### 4.2 Intrinsic safety

- The device is approved for intrinsically safe (protection type Ex i) circuits up to zone 0 (gas) and zone 20 (dust) in the hazardous area.

Observe the safety values for intrinsically safe equipment and the connecting cables during connection (IEC/EN 60079-14). They must conform to the values specified in the installation manual, in this data sheet, or the EC-type examination certificate.

- When carrying out measurements on the intrinsically safe side, observe the relevant regulations regarding the connection of intrinsically safe equipment. In intrinsically safe circuits, only use those measuring devices that are approved for these circuits.
- If the device has been used in non-intrinsically safe circuits, it must not be used again in intrinsically safe circuits. The device must be clearly marked as non-intrinsically safe.

### 4.3 Installation in the hazardous area (zone 2)

- Observe the specified conditions for use in potentially explosive areas!  
Install the device in a suitable approved housing (with at least IP54 degree of protection) that meets the requirements of EN 60079-15. Observe the requirements of EN 60079-14.
- Always disconnect the power before connecting or disconnecting non-intrinsically safe cables.
- The device must be stopped and immediately removed from the hazardous area if it is damaged or was subjected to an impermissible load or stored incorrectly or if it malfunctions.

### 4.4 Areas with a danger of dust explosions

- The device is not designed for installation in zone 22.
- If, however, you wish to use the device in zone 22, it must be installed in a housing that complies with IEC/EN 60079-31. In doing so, observe the maximum surface temperatures. Observe the requirements of IEC/EN 60079-14.
- Connection to the intrinsically safe circuit in areas with a danger of dust explosions (Zone 20, 21 or 22) is only permitted if the equipment connected to this circuit is approved for this zone (e.g. Category 1D, 2D or 3D).

### 4.5 Safety-related applications (SIL)

When using in safety-related applications, observe the instructions in Section 7, as the requirements differ for safety-related functions.

## 5 Installation

### 5.1 Connection notes



**WARNING: Electrical danger due to improper installation**

Observe the connection notes for safe installation in accordance with EN/UL 61010-1:

- Near the device, provide a switch/circuit breaker that is labeled as the **disconnect device** for this device (or the entire control cabinet).
- Provide **overcurrent safety equipment** ( $I \leq 16 \text{ A}$ ) in the installation.
- To protect the device against mechanical or electrical damage, install it in a suitable **housing** with an appropriate degree of protection according to IEC 60529.
- If **several devices are installed next to each other**, make sure that the device has a housing that features a basic insulation for  $300 \text{ V}_{\text{eff}}$ . Install additional insulation, if necessary. If the neighboring device is equipped with basic insulation, no additional insulation is required.
- The voltages present at the input, output, and supply are extra-low voltages (**ELV**). Depending on the application, dangerous contact voltages ( $> 30 \text{ V AC}/> 60 \text{ V DC}$ ) to ground may be present at the device.
- During **servicing and maintenance work**, disconnect the device from all effective power sources, if you are not dealing with SELV or PELV circuits.
- Always disconnect the device from the power before switching the **DIP switches**.
- If the device is not used as described in the documentation, the intended protection may be impaired.

### 5.2 Electrostatic discharge



**NOTE: Electrostatic discharge!**

The device contains components that can be damaged or destroyed by electrostatic discharge. When handling the device, observe the necessary safety precautions against electrostatic discharge (ESD) according to EN 61340-5-1 and IEC 61340-5-1.

### 5.3 Design

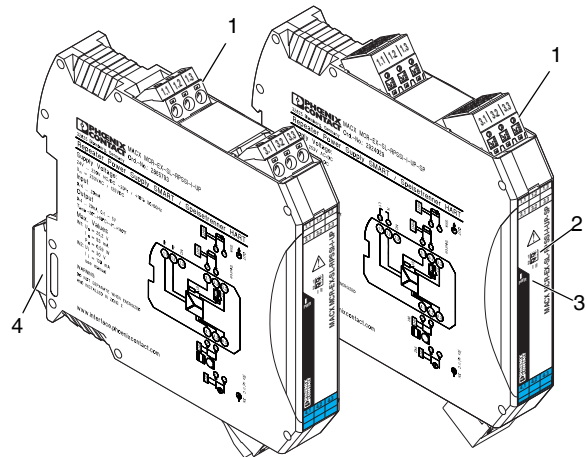

Figure 1 Design MACX MCR-EX-SL-RPSSI-I-UP(-SP)

- 1 Plug-in COMBICON screw or push-in terminals with integrated test sockets
- 2 Green LED "PWR", supply voltage
- 3 DIP switches
  - S1 = Switchover output current/voltage
  - S2 = Resistance in the output circuit to increase the HART impedance
- 4 Snap-on foot for fixing to the DIN rail

**5.4 Basic circuit diagram**

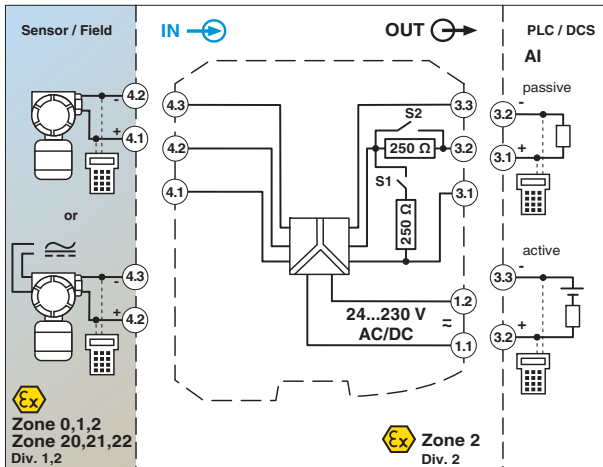

Figure 2 Basic circuit diagram with connection terminals

**5.5 Input (intrinsically safe)**

- **Repeater power supply operation** (feeding input for 2-wire transmitter or 2-wire measuring transducer)  
Connection to terminal 4.1 (+) and 4.2 (-)
- **Input signal conditioner operation** (non-feeding input for 4-wire transmitter or current sources)  
Connection to terminal 4.2 (+) and 4.3 (-)

**5.6 Output current (without HART communication)**

Operating mode	Connection of input card to terminal	DIP	
		S1	S2
<b>Source</b> (passive input card)	3.1 (+) and 3.2 (-)	I	II
<b>Drain</b> (active input card)	3.2 (+) and 3.3 (-)	I	II

**5.7 Output current (with HART communication)**

Operating mode	Circuit impedance	Connection		DIP	
		of the input card on the terminal	of the HART communicator*	S1	S2
<b>Source</b>	$\geq 250 \Omega$	3.1 (+) and 3.2 (-)	3.1 and 3.2	I	II
	$< 250 \Omega$	3.1 (+) and 3.2 (-)	3.2 and 3.3	I	I
<b>Drain</b>	$\geq 250 \Omega$	3.2 (+) and 3.3 (-)	3.2 and 3.3	I	II
	$< 250 \Omega$	3.2 (+) and 3.3 (-)	-	I	II

\* Connection of the HART communicator to the test sockets of the terminals

**5.8 HART communicators**

HART communicators can be connected as shown in the basic circuit diagram. Test sockets (diameter 2.3 mm) are integrated in the connection terminals for this purpose.

**5.9 Output, voltage**

Operating mode	Connection of input card to terminal	DIP	
		S1	S2
<b>Source</b> (passive input card)	3.1 (+) and 3.2 (-)	II	II

**5.10 Supply voltage**

The supply voltage is fed in through the connection terminals 1.1 (+) and 1.2 (-) (24 V DC ... 230 V DC).



### 5.11 Dimensions

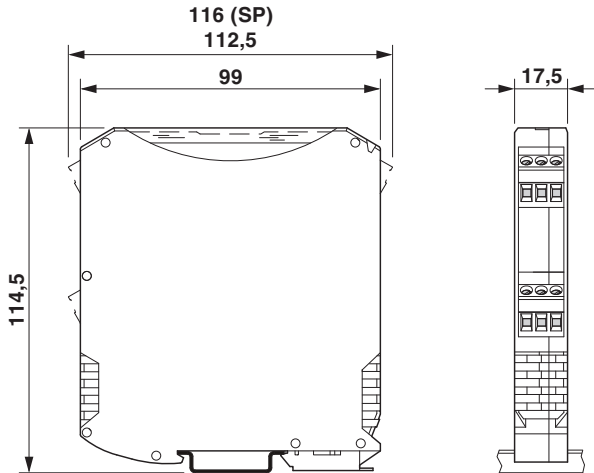

### 5.12 Assembly

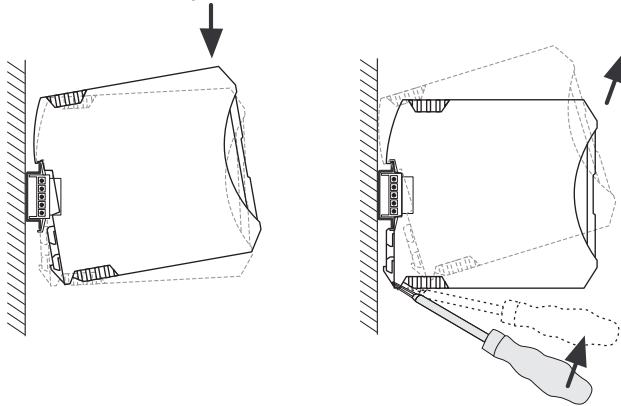

Figure 3 Assembly and Removal

- Mount the module on a 35 mm DIN rail according to EN 60715.
- Install the module in suitable housing to meet the requirements for the protection class.

### 5.13 Connection of the cables

#### Screw connection

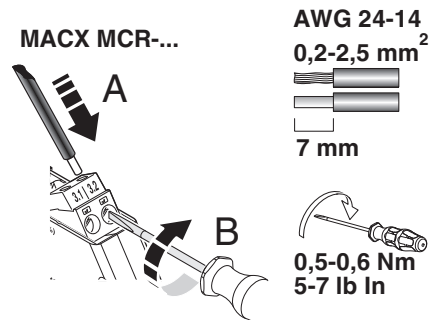

Figure 4 Screw connection

Permissible conductor cross section: 0.2 mm<sup>2</sup> ... 2.5 mm<sup>2</sup>

- Strip the wire by approximately 7 mm and crimp ferrules to the end of the wires.
- Insert the conductor into the corresponding connection terminal.
- Use a screwdriver to tighten the screw in the opening above the connection terminal.

Connection torque: 0.6 Nm

#### Spring connection (push-in connection)

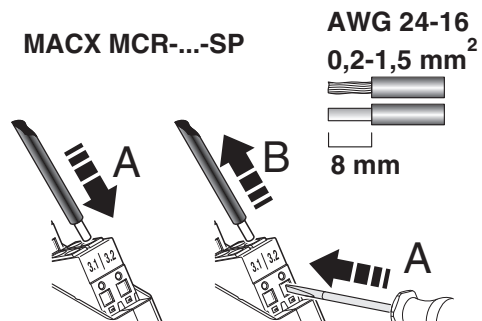

Figure 5 Push-in connection

Permissible conductor cross section: 0.2 mm<sup>2</sup> ... 1.5 mm<sup>2</sup>

- Strip the wire by approximately 8 mm and crimp ferrules to the end of the wires.
- Insert the wire into the round opening of the terminal without using a tool.
- Push in the pushbutton with a screwdriver to release.

### 5.14 Startup

- Before startup, check that the repeater power supply and input signal conditioner Ex is wired correctly, in particular with regard to the wiring and marking of the intrinsically safe circuits.

### 5.15 Level shift

No signal-level shifting is planned between input and output. 4 ... 20 mA input signals therefore become 4 ... 20mA output signals.

In the same way, active input signals from 0 ... 20 mA become electrically isolated 0 ... 20mA output signals.

## 6 Comparison of safety data



### WARNING: Explosion hazard

Compare the safety data before connecting a device located in the Ex-i area to the MACX MCR-EX-SL-RPSSI-I-UP(-SP).

Provide proof of intrinsic safety according to standard IEC/EN 60079-14 and other national standards and installation specifications, if applicable.

Safety data for the

Field devices:  $V_i, I_i, P_i, L_i, C_i$   
 Repeater power supplies, Ex i:  $V_o, I_o, P_o, L_o, C_o$

The values for  $V_o, I_o, P_o, L_o$ , and  $C_o$  can be found under "Safety data according to ATEX for intrinsically safe circuits" on page 5.

### Example for proof of intrinsic safety for intrinsically safe circuit with one source

$$V_i \geq V_o$$

$$I_i \geq I_o$$

$$P_i \geq P_o$$

$$\left. \begin{array}{l} L_i + L_c \leq L_o \\ C_i + C_c \leq C_o \end{array} \right\} \text{Condition: } L_i \leq 1\% \text{ of } L_o \text{ or } C_i \leq 1\% \text{ of } C_o$$

$$\left. \begin{array}{l} L_i + L_c \leq 0.5 L_o \\ C_i + C_c \leq 0.5 C_o \end{array} \right\} \text{Condition: } L_i > 1\% \text{ of } L_o \text{ and } C_i > 1\% \text{ of } C_o$$

$L_c$  and  $C_c$  depend on the cables/lines used.

## 7 Safety-related applications (SIL 2)

SIL regulations apply to the following modules:

Designation	Order No.
MACX MCR-EX-SL-RPSSI-I-UP	2865793
MACX MCR-EX-SL-RPSSI-I-UP-SP	2924029
MACX MCR-SL-RPSSI-I-UP	2865968
MACX MCR-SL-RPSSI-I-UP-SP	2924210

The safety-related repeater power supply and input signal conditioners listed above are certified as conform with DIN EN 61508-1:11.2002. Test certificate: BVS Pb 09/08

### 7.1 Safety function and safety demand

The device performs the safety function of electrically isolated forwarding of a 4...20mA standard signal with a maximum deviation of 5% maximum.

Output values outside this range of 3.6 ... 21 mA are considered as the safe state, which is detected by the subsequent controller.

**Safe failures** in the device are therefore those errors where the repeater power supply and input signal conditioner sends an output signal that deviates from the input signal by no more than 5%.

**Dangerous, non-detectable failures** are errors where the repeater power supply and input signal conditioner does not follow a change in the input signal or deviates from the input signal by more than 5% and is not outside the range.

**Dangerous, detectable failures** are those that send a signal outside the range (< 3.6 mA and > 21 mA).

### 7.2 Safety integrity requirements

#### Failure rates

- Type A device (according to IEC/EN 61508-2)
- Safety Integrity Level (SIL) 2
- HFT = 0
- MTTR = 24 h
- 1oo1 structure
- Ambient temperature: 40 °C

### Operation as a repeater power supply

$\lambda_{SD}$	$\lambda_{SU}$	$\lambda_{DD}$	$\lambda_{DU}$	SFF	DC <sub>D</sub>
0 FIT	557.7 FIT	0 FIT	58.3 FIT	90.55%	0%

The total failure rate is 622 FIT.

The MTBF is 183 years.

The probability of a dangerous failure per hour for "continuous demand" mode and the average probability of failure of the specified function for "low demand" mode are determined based on the error rates:

#### PFD<sub>avg</sub> values

T <sub>[PROOF]</sub> =	1 year	3 years	4 years
PFD <sub>avg</sub> =	2.53E-04	7.66E-04	1.02E-03

$$PFH = 5.83 \cdot 10^{-8}/h$$

This fulfills the requirements for the PFH value for a SIL 2 system.

The boxes marked in gray show that the calculated PFD<sub>avg</sub> values are within the permissible range for SIL 2 in accordance with Table 2 of IEC/EN 61508-1. They fulfill the requirement to not cover more than 10% of the safety circuit, i.e., to be better than or equal to 1.00E-03.

The box marked in white shows that the calculated PFD<sub>avg</sub> values are within the permissible range for SIL2 in accordance with Table 2 of IEC/EN 61508-1. However, they do not fulfill the requirement to not cover more than 10% of this safety circuit, i.e., to be better than or equal to 1.00 E03.

#### Failure limit

The data is based on an operating mode with low demand rate. The device covers less than 10% of the PFH/PFD of the entire safety circuit.

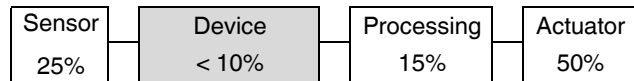

Figure 6 Safety circuit

### 7.3 Condition

The values are valid under the following conditions:

- The failure rates of the components used remain constant throughout the period of use.
- The propagation of errors by the device in the system is not taken into consideration.
- The failure rates of the external power supply are not taken into consideration.
- The specified error rates are based on an average ambient temperature of +40 °C. For an average ambient temperature of +60 °C, the specified failure rates must be multiplied by a factor of 2.5. This factor is based on guide values.

### 7.4 Installation and Startup



**NOTE:** Installation, operation, and maintenance may only be carried out by qualified electricians.

During installation, also follow the installation notes, which pertain to delivery of the device. (PACKB.MACX MCR-EX-SL-RPSSI-I-UP(-SP), MNR 9040229). They can also be downloaded at [phoenixcontact.net/products](http://phoenixcontact.net/products).

Lockable housing with IP54 protection is recommended for the installation of the repeater power supply and input signal conditioner.

- Connect the repeater power supply and input signal conditioner according to the installation manual.
- Make sure that the connected sensor and measuring transducer correspond to the intended configuration.
- Check that the repeater power supply and input signal conditioner operates correctly with the measuring transducer and sensor connected.
- A calibrated sensor simulator and a calibrated digital multimeter may be required in order to check the repeater power supply and input signal conditioner with the measuring transducer connected.
- Start up the safety circuit and check that it operates correctly.

### 7.5 Notes on operation

During normal operation, the green (PWR) LED is always on.

If a failure occurs during operation, the output signal is usually set to a value outside the normal signal range of 3.6 ... 21 mA. The connected safety-related controller should therefore check the validity of the read signal values and initiate appropriate measures in the event of deviations from the normal values.

You should make sure that the connected measuring transducers respond to line faults at the sensors.

After being switched off and on again, the required voltages are established in the device. Signal transmission is then performed without further action.

### 7.6 Recurring checks

- Check the function of the entire safety circuit according to IEC/EN 61508 and EN 61511. The intervals for checking are specified by the intervals of each individual device within the safety circuit.

It is the operator's responsibility to select the type of checks and the checking intervals in the specified time period.

Checking must be carried out in such a way that the correct function of the safety equipment in conjunction with all components can be verified.

In SIL 2 applications, the repeater power supply and input signal conditioners need to be checked at the latest after the maximum maintenance/test interval, if they cover a share of no more than 10% of the total safety circuit.

### Possible procedure for recurring checks for discovering dangerous and undetected device failures

The following are necessary for inspecting the repeater power supply and input signal conditioner:

- 1 calibrated current simulator (0/4 ... 20 mA) or 1 sensor simulator
  - 1 – 2 calibrated digital multimeter
1. Take appropriate steps to prevent incorrect use and disconnect the safety circuit from further processing.  
If you use a current simulator, connect it to the input of the repeater power supply and input signal conditioner.  
If you use a sensor simulator, connect it to the input of the measuring transducer.  
Connect the digital multimeters to the inputs and outputs of the repeater power supply and input signal conditioner.
  2. If you use a current simulator, you should apply a signal at the input of the device in the range of 4° ... 20 mA.  
If you are using a sensor simulator, set a suitable signal at the input of the connected measuring transducer.  
Measure the current in the feed and input signal conditioners. The outputs have to be set to the same value.
  3. Setting  $\leq 3.6$  mA or  $> 21$  mA ensures that the subsequent processing can detect signals that are out of range and evaluate them accordingly.  
If the output value deviates from the input value by more than three times the specified class accuracy rating, the device should be checked.  
In the event of an error, the device should be replaced with an equivalent device.
  4. Restore the safety circuit to full functionality.
  5. Resume normal operation.

### 7.7 Repair

The devices have a long service life, are protected against malfunctions, and are maintenance-free. However, if a device should fail, send it back to Phoenix Contact. The type of malfunction and possible cause has to be stated.

Please use the original packaging or other suitable safe packaging when sending devices back for repairs.

Phoenix Contact GmbH & Co KG  
Abteilung Service und Reparatur  
Flachmarktstr. 8  
32825 Blomberg  
GERMANY

### 7.8 Standards (SIL 2)

The devices are developed and tested according to the following standards:

DIN EN 61508-1:11.2002	Functional safety of electrical/electronic/programmable electronic safety-related systems - Part 1: General requirements
EN 61326-1:2006	Electrical equipment for measurement, control and laboratory use - EMC requirements - Part 1: General requirements
IEC 61326-3-2:2006	Electrical equipment for measurement, control, and laboratory use - EMC requirements - Part 3-2: Immunity requirements for safety-related systems and for equipment intended to perform safety-related functions (functional safety) - General industrial applications in specified electromagnetic environment

## 7.9 Abbreviations

Abbreviation		Meaning
DC	Diagnostic Coverage	Diagnostic coverage of safe failures ( $DC_S$ ) or dangerous failures ( $DC_D$ )
FIT	Failure in Time	Number of failures that occur in $10^9$ hours
HFT	Hardware Fault Tolerance	Hardware fault tolerance: ability of a function unit to continue with the execution of a demanded function despite existing faults or deviations
MTBF	Mean Time Between Failures	Indicates the average time period between one failure and the next. This includes the length of time that the component functions for until the failure and the downtime.
MTTR	Mean Time To Repair	Indicates the average time needed in order to repair a faulty component.
$PF_{D_{avg}}$	Average Probability of dangerous Failure on Demand	Average probability of failure on demand of a safety function
PFH	Probability of a Dangerous Failure per Hour	Probability of failure per hour for the safety function
SFF	Safe Failure Fraction	Proportion of safe failures: Proportion of failures without the potential to set the safety-related system to a dangerous or impermissible function state
SIL	Safety Integrity Level	IEC/EN 61508 defines four safety integrity levels (SIL 1 to 4). The higher the Safety Integrity Level of the safety-related system, the lower the probability range for the failure of a safety function.
$\lambda$	The failure rate $\lambda$ indicates the number of errors per time unit. DD Dangerous Detected DU Dangerous Undetected SD Safe Detected SU Safe Undetected	

Компания «Life Electronics» занимается поставками электронных компонентов импортного и отечественного производства от производителей и со складов крупных дистрибьюторов Европы, Америки и Азии.

С конца 2013 года компания активно расширяет линейку поставок компонентов по направлению коаксиальный кабель, кварцевые генераторы и конденсаторы (керамические, пленочные, электролитические), за счёт заключения дистрибьюторских договоров

Мы предлагаем:

- Конкурентоспособные цены и скидки постоянным клиентам.
- Специальные условия для постоянных клиентов.
- Подбор аналогов.
- Поставку компонентов в любых объемах, удовлетворяющих вашим потребностям.
- Приемлемые сроки поставки, возможна ускоренная поставка.
- Доставку товара в любую точку России и стран СНГ.
- Комплексную поставку.
- Работу по проектам и поставку образцов.
- Формирование склада под заказчика.
- Сертификаты соответствия на поставляемую продукцию (по желанию клиента).
- Тестирование поставляемой продукции.
- Поставку компонентов, требующих военную и космическую приемку.
- Входной контроль качества.
- Наличие сертификата ISO.

В составе нашей компании организован Конструкторский отдел, призванный помогать разработчикам, и инженерам.

Конструкторский отдел помогает осуществить:

- Регистрацию проекта у производителя компонентов.
- Техническую поддержку проекта.
- Защиту от снятия компонента с производства.
- Оценку стоимости проекта по компонентам.
- Изготовление тестовой платы монтаж и пусконаладочные работы.



Тел: +7 (812) 336 43 04 (многоканальный)

Email: [org@lifeelectronics.ru](mailto:org@lifeelectronics.ru)